



Your technology partner for cost-effective machining

DIE & MOULD



Tool and process solutions combined with comprehensive services

We see ourselves as a technology partner ready to support you in the development of efficient and resource-saving manufacturing processes with standard tools, individual tool concepts and tool detail optimisation. Our tools meet the requirements for process reliability, offer high levels of precision and are easy to handle. How do we achieve this? Through advanced development and construction methods and production at state-of-the-art manufacturing facilities.

You're looking for the perfect tool for your task but also want to find a partner who can take over and manage the entire planning stage of your process? If that sounds familiar, we're here for you. We support you during all phases of production and keep your manufacturing processes at the highest level – by being highly productive, economical and process-reliable. We also offer you complete networked solutions for all peripheral tasks related to the actual machining process.

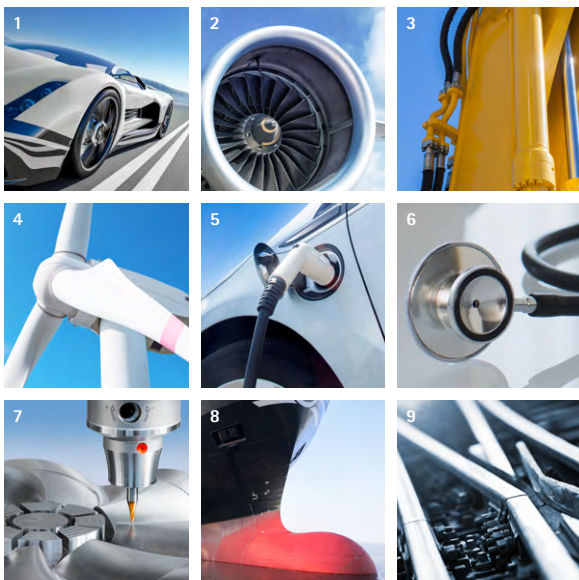

Sectors

- 1 Automotive
- 2 Aerospace
- 3 Fluid technology
- 4 Energy production
- 5 Electric mobility
- 6 Medical technology
- 7 Die & mould
- 8 Shipbuilding
- 9 Rail transport



Over
5,000
 employees worldwide

No. 1
 technology leader
 for the machining
 of cubic parts



Product lines

- 1 Reaming and fine boring
- 2 Drilling from solid, boring and countersinking
- 3 Milling
- 4 Turning
- 5 Actuating
- 6 Clamping
- 7 Setting, measuring and dispensing
- 8 Services

New catalogues:

BORE MACHINING, MILLING, CLAMPING

MAPAL has published new catalogues for the bore machining, milling and clamping areas. The product ranges' assortments have been comprehensively revised and adapted to customer needs even more.

In addition to established products, the catalogue includes a number of innovations. Over a total of 1,500 pages, users can find 13,500 products from which to select the perfect boring or milling tool and matching clamping device for practically all machining tasks. By streamlining the range, high availability from stock has been guaranteed for the tools. MAPAL therefore offers quick delivery times without sacrificing quality. Around 80 per cent of listed items are available ex works in Germany. These products can be delivered immediately after receiving your order.

MAPAL has consolidated the previously separate catalogues for the product groups drilling from solid, boring, countersinking as well as reaming and fine boring into a single new bore machining catalogue.

Items no longer listed in the new catalogue can still be ordered upon request.

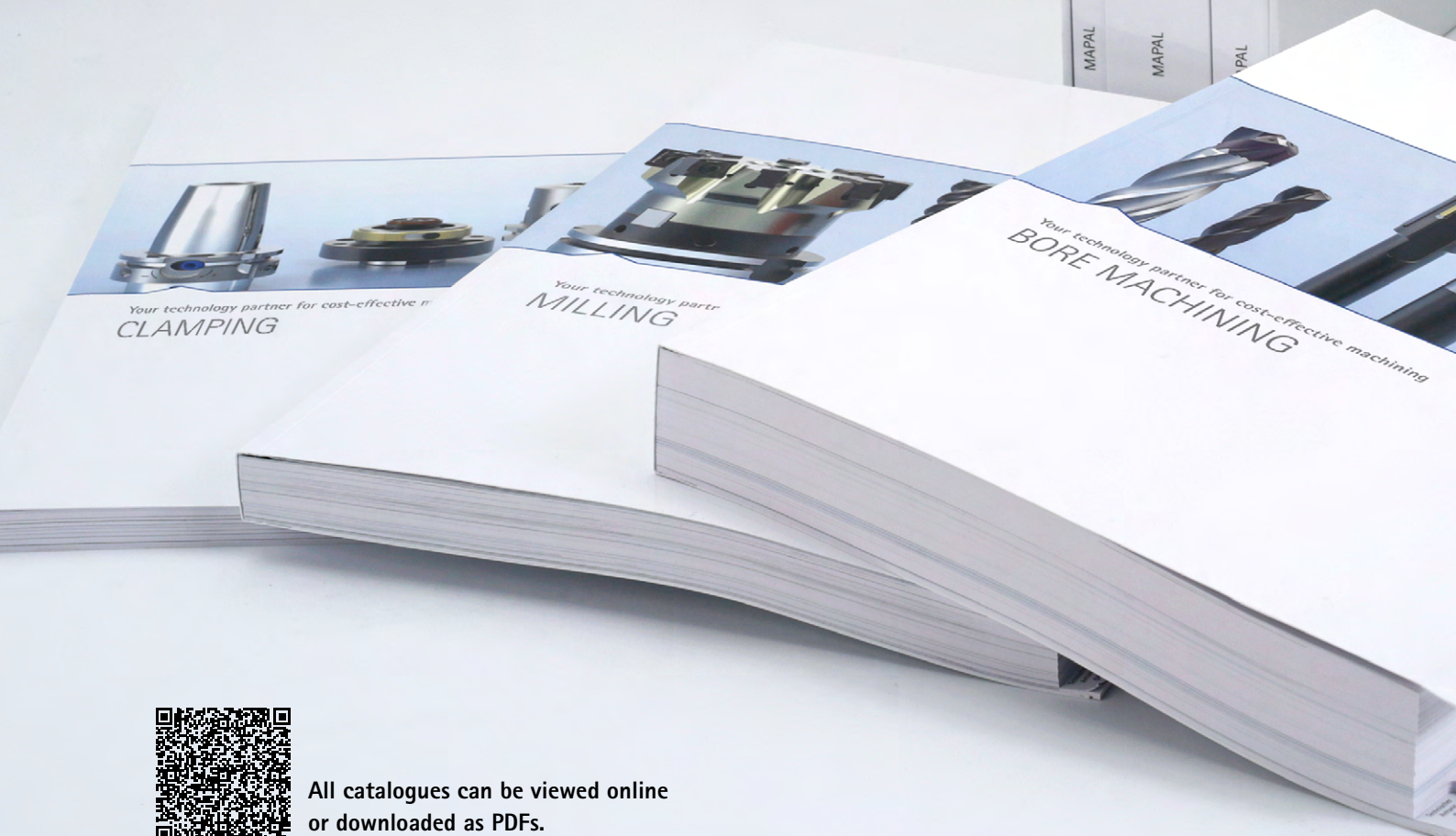
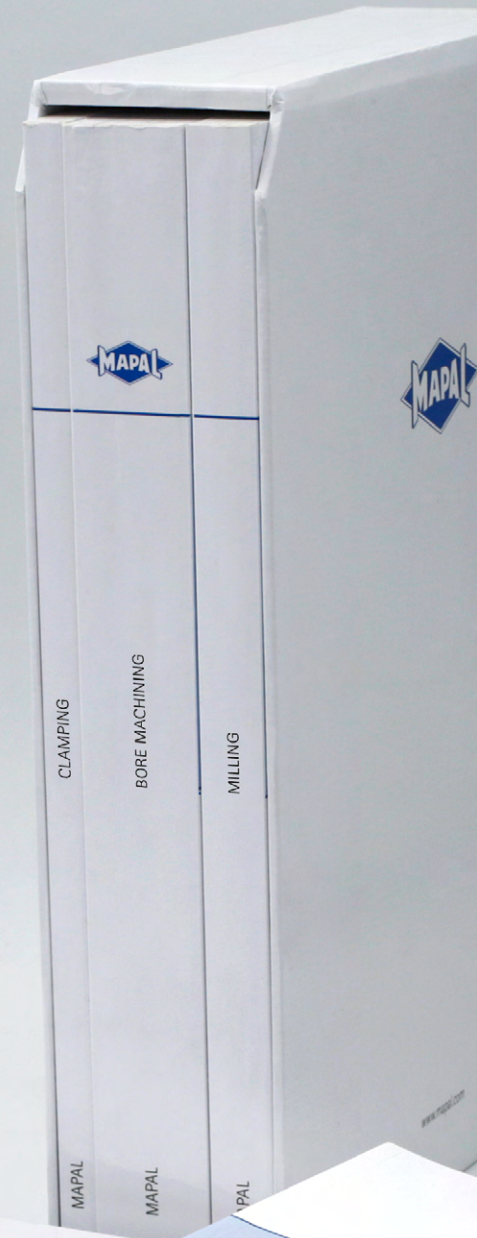

All catalogues can be viewed online
or downloaded as PDFs.

CONTENTS

01 Introduction

Technology partner and complete supplier	6
Overview of range	8
Reconditioning	10

02 Milling with solid carbide and PCD

Product overview, selection guide, product ID codes	16
Ball nose milling cutter	31
Corner radius milling cutter	79
Circle radius milling cutter	141
High-feed milling cutters	151
Shoulder milling cutter	163
Trochoidal milling cutters	213
Engraving and deburring	227

03 Milling with indexable inserts

Product overview, selection guide, product ID codes	236
Ball and corner radius milling cutter	257
Round-insert milling cutters	269
High-feed and 90° shoulder milling cutters	285
Finishing milling cutters	309

04 Drilling from solid | Countersinking

Product overview, selection guide, product ID codes	318
Drilling from solid using solid carbide	329
Drilling from solid with replaceable head system	396
Countersinks	402

05 Reaming

Product overview, product ID codes	432
Reamers	437

06 Clamping

Product overview, technology, product ID codes	446
Chucks	451

07 Setting | Measuring | Dispensing

Setting fixtures, smart dispensing systems	537
--	-----

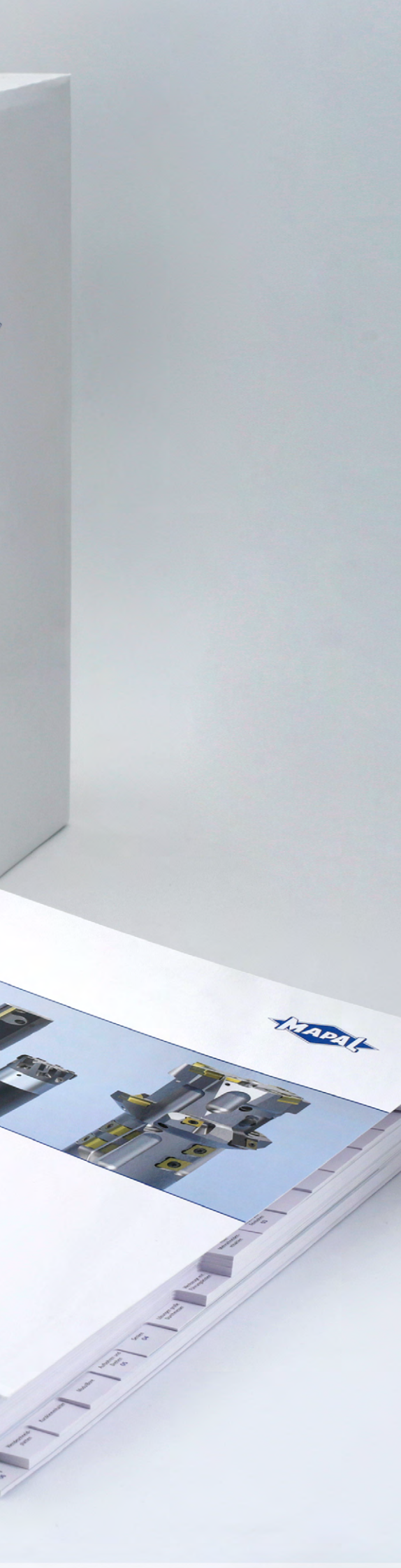

Technology partner and complete supplier in the die & mould

Apart from tools and chucks, MAPAL supplies complete processes and the path to digital manufacturing.

Companies that make dies and moulds expect high process and product expertise from their cutting tools manufacturer. This is because the tool life of the moulds to be created and the precision of the moulded parts are extremely important for competitiveness in mass production. Therefore, they require their tools to offer the highest levels of precision, a long tool life, and – above all – process reliability.

It is precisely these aspects that make MAPAL successful in sectors such as the automotive industry, machine engineering and the aerospace industry. So it shouldn't come as a surprise that the precision tool manufacturer is now also offering efficient and economical solutions for the complete machining process in the die & mould. Versatile and precise high-performance tools and special tool holders with thin contours and a precise radial run-out minimise polishing work and reworking thanks to a constant surface finish in the milling process.

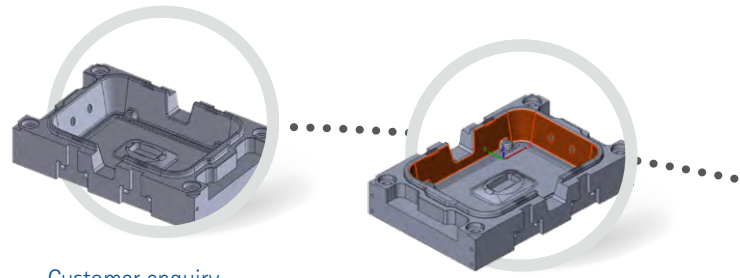

Customer enquiry

MAPAL sales representatives are directly available for individual enquiries. In a personal conversation with the customer, they sound out the specific requirements and the scope (complete or partial machining) and discuss the details directly on the 3D model of the component.

Project analysis

On the basis of 3D models and machine data, the conversation partners analyse the manufacturing tasks and develop effective machining strategies.

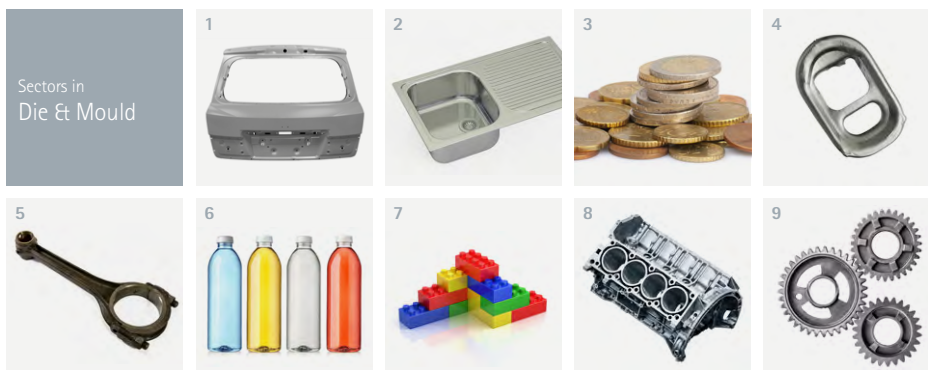

- 1 Sheet metal forming
- 2 Deep drawing
- 3 Coining
- 4 Stamping
- 5 Forging
- 6 Blow moulding
- 7 Injection moulding
- 8 Pressure die casting – permanent mould casting
- 9 Sintering

Why use MAPAL?

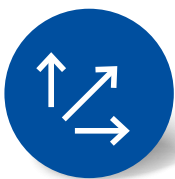

Everything from a single source

At MAPAL, customers can get everything they need from a single source and take advantage of our specialist knowledge in tooling and processing.



Partnership

The basis of everything we do at MAPAL is a close, open dialogue with all customers and, as a result, a long-term partnership on an equal footing.



Quality and precision

MAPAL tools stand for the highest level of quality and economic efficiency. They are characterised by excellent dimensional accuracy and the highest level of precision.

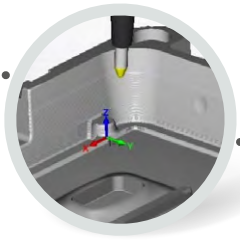

Process design

Regardless of whether the focus is on flexibility or productivity: the machining specialists simulate the developed process on the basis of the 3D models and thus show potential for optimisation. They check and improve the machining parameters in CAM programming and thus ensure stable and economical manufacturing.

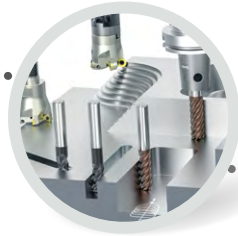

Tool solution

The wide-ranging MAPAL standard range for the die & mould offers the ideal tool solution for every application. Customised solutions are available upon request.



Tool test and offer

After discussing the machining task, MAPAL supports its customers in the selection of tools required in the process. This is the basis for a well-founded offer tailored to the respective application.



Cooperative partnership

Even after a successful start of production, the specialists at MAPAL remain in close contact with the customer. Should optimisation potential arise over time or other tools turn out to be better, MAPAL will be happy to support you to further improve productivity and cost-effectiveness.



Find out more at:
www.mapal.com



Standard range

The range of highly capable tools available from stock ensures excellent and reliable results for all machining tasks.



Technology leadership

In the machining of cubic components, MAPAL is the technology leader worldwide.



On the ground all over the world

Customer focus isn't just a buzzword at MAPAL – it forms an essential part of our corporate identity. On a global basis.

OVERVIEW OF RANGE

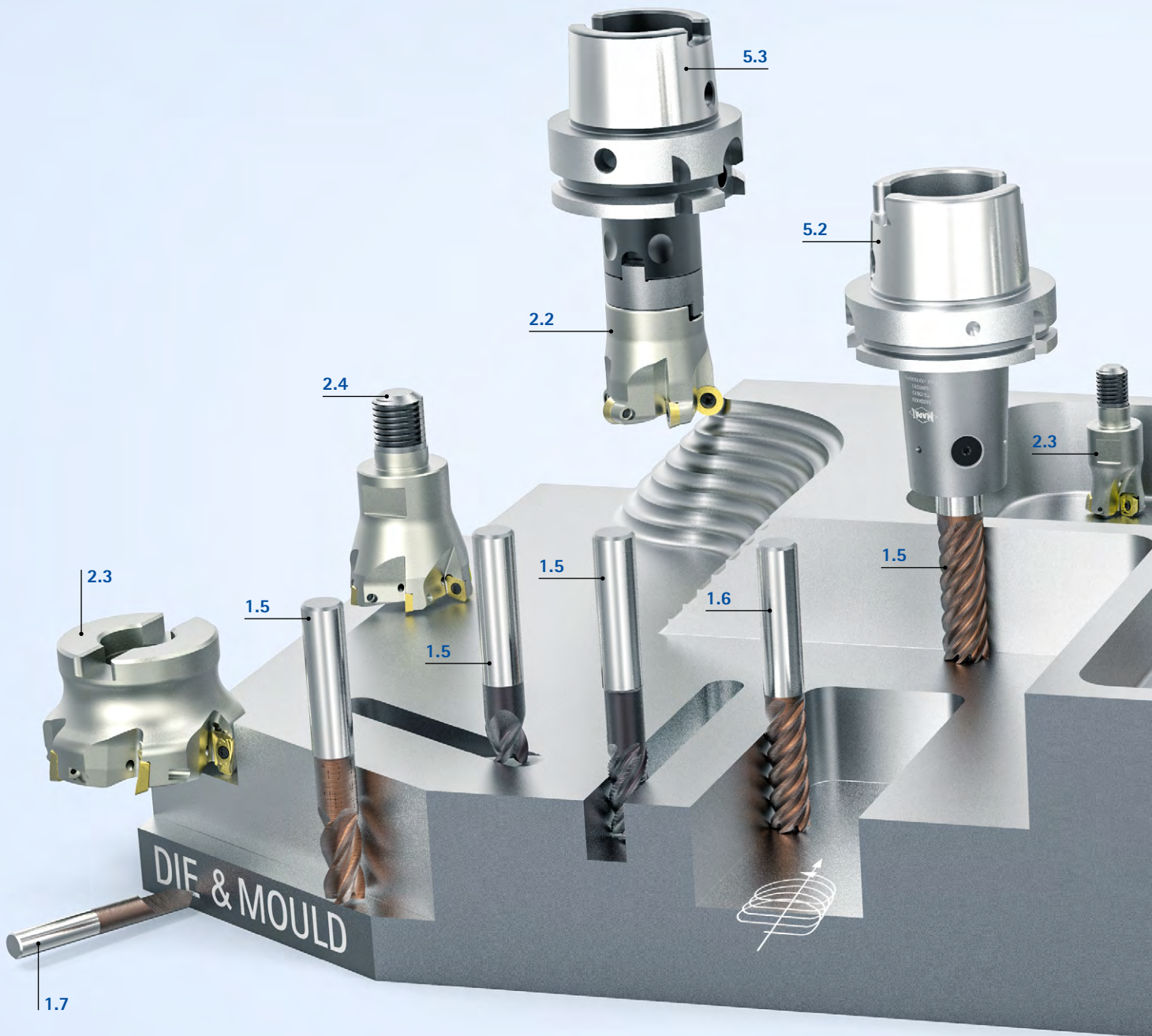

1 Milling with solid carbide and PCD

- 1.1 Ball nose milling cutter (from page 31)
- 1.2 Corner radius milling cutter (from page 79)
- 1.3 Circle radius milling cutter (from page 141)
- 1.4 High-feed milling cutter (from page 151)
- 1.5 Shoulder milling cutter (from page 163)
- 1.6 Trochoidal milling cutter (from page 213)
- 1.7 Engraving and deburring milling cutter (from page 227)

2 Milling with indexable inserts

- 2.1 Bell and corner radius milling cutter (from page 257)
- 2.2 Round-insert milling cutter (from page 269)
- 2.3 High-feed and 90° shoulder milling cutter (from page 285)
- 2.4 Finishing milling cutter (from page 309)

3 Drilling from solid | Countersinking (from page 318)

- 3.1 Solid drills
- 3.2 Deep drills
- 3.3 Countersink
 - Drill reamer
 - Replaceable head drill
 - Step drill



4 Reaming (from page 432)

- 4.1 High-performance reamers
- Replaceable head reamers
 - Quick-adjustable reamers
 - Reamers with guide pads

5 Clamping (from page 446)

- 5.1 Hydraulic chuck
- 5.2 Side lock chuck
- 5.3 Milling cutter arbors
- Shrink chuck
 - Precision drill chuck
 - Screw-in holders

WORLDWIDE RECONDITIONING SERVICE

It doesn't matter where in the world you're manufacturing your products: you can be sure that you will be able to take advantage of our on-site services for reconditioning your tools to original MAPAL quality.



CONSISTENT
QUALITY STANDARDS
WORLDWIDE



MANUFACTURING AND RECONDITIONING TOOLS
FROM A SINGLE SOURCE



RECONDITIONING AVAILABLE WORLDWIDE WITH
IDENTICAL
MACHINES AND SOFTWARE



CONTACT PARTNERS
STATIONED IN EVERY COUNTRY



SERVICE ON SITE
EVEN FOR COMPLEX TOOL SYSTEMS



EASY, QUICK AND TIMELY
PROCESSING



HIGH-QUALITY
EQUIPMENT, GRINDING WHEELS, ETC.



LOCAL SERVICE CENTRES
ENABLE US TO SERVE ALL PRODUCTION SITES



QUALIFIED, SPECIALLY
TRAINED SERVICE PERSONNEL
WORLDWIDE

RECONDITIONING TO MAPAL QUALITY

After your tools are reconditioned at MAPAL you'll receive them back at premium quality within a very short time. To speed things up even more, we are also able to collect your tools and deliver them again once processed upon request.

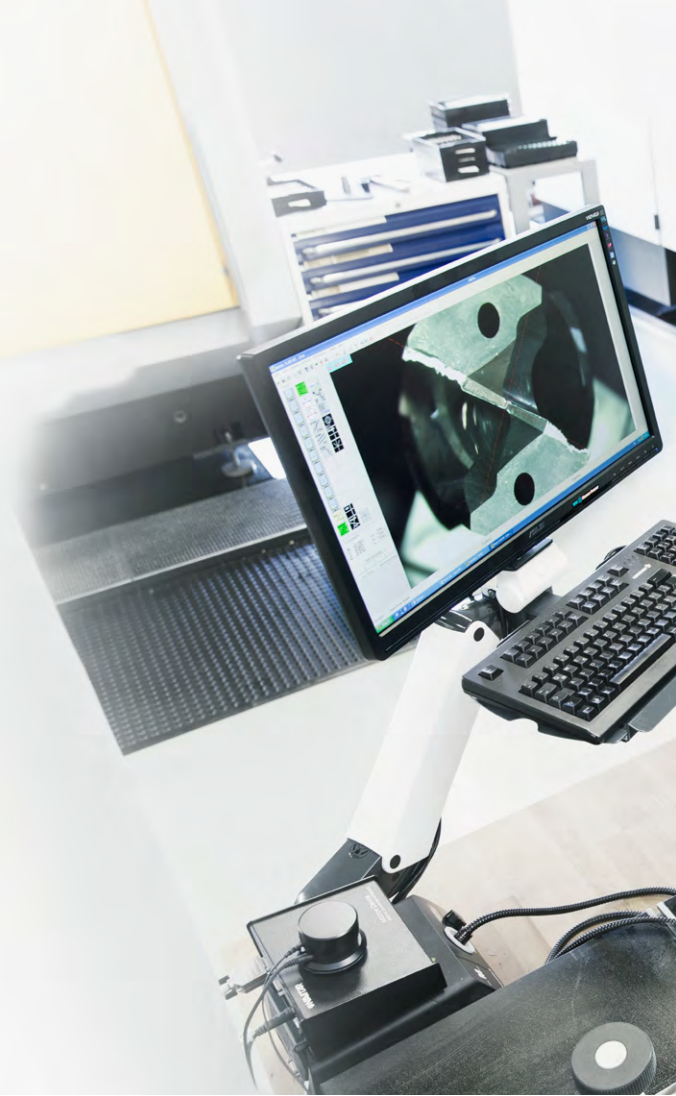

We're happy to recondition MAPAL tools and tools made by other companies



By reconditioning your tools to original MAPAL quality, they can again achieve almost the exact same tool life as newly purchased tools. That saves you money.

- Grinding and coating
- Re-eroding
- Retipping with indexable inserts or milling inserts
- Replacing worn parts
- Chrome plating and regrinding shafts
- Measurement report service

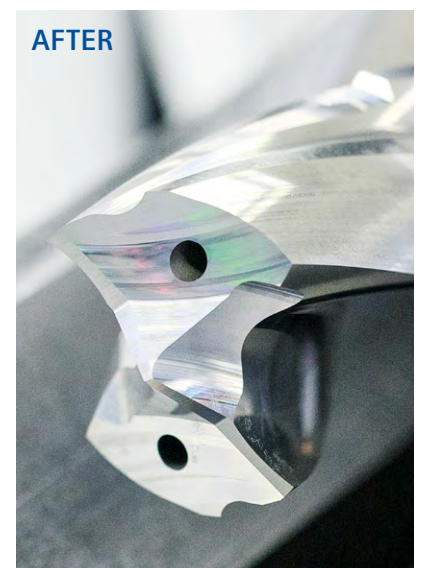
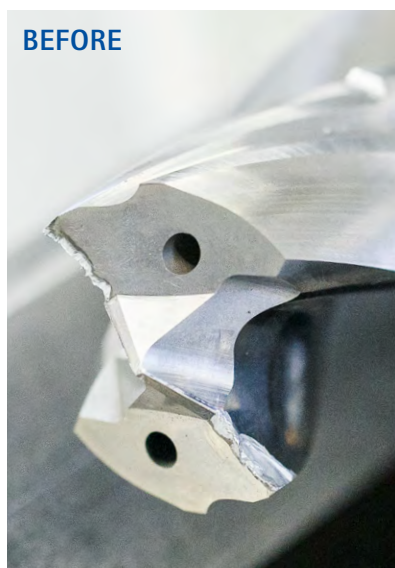



SAFE PACKAGING

available upon request with the MAPAL Toolbox for safe transport there and back.

PROMPT COLLECTION

and fast, cost-effective transport by the MAPAL delivery service or parcel service.

DETAILED PRELIMINARY CHECK

available upon request to check whether reconditioning is worthwhile.

REGRINDING TO ORIGINAL QUALITY

carried out by specialist personnel on state-of-the-art machines.

ORIGINAL COATING

guarantees a tool life that is comparable to that of new tools.

EXACT QUALITY CONTROL

with the latest measuring technology in MAPAL quality.

FAST RETURNS

delivered as quickly as possible by the MAPAL delivery service or parcel service.

COST SAVINGS OF 65%

when a MAPAL twist drill made of solid carbide with a high-performance coating is reconditioned four times.

We would be happy to recondition these tools for you

	SINGLE-STAGE		MULTI-STAGE
	Full regrinding	Retipping	Axial/radial regrinding Full/partial retipping *
TOOLS MADE FROM SOLID CARBIDE	✓	-	-
TOOLS WITH PCD	✓	✓	✓
FIXED MULTI-BLADED REAMERS	✓	✓	-
QTD INDEXABLE INSERTS	✓	-	-

* The type and scope of the repair depends on the tool in question.



MILLING WITH SOLID CARBIDE AND PCD

Solid carbide milling cutters for economical and process-reliable machining in the die & mould sector.



PRODUCT OVERVIEW

Milling with solid carbide and PCD

MAPAL's range of highly capable tools ensures excellent and reliable results for all machining tasks in the die & mould sector. Cost-effectiveness and product quality are particularly important when meeting customer requirements.

Efficiency





MAPAL is now offering a new, powerful range of solid carbide milling cutters specifically developed for the die & mould sector under the product name OptiMill-3D. In addition to extremely heat-resistant coatings and special carbide substrates, these tools are characterised by dimensions and geometries adapted to mould making. Rounded cutting edges also ensure a long tool life.

Application-based





The range of end milling cutters includes ball and corner radius milling cutters with a high-precision radius as well as high-feed and circle radius milling cutters for highly efficient machining. Shoulder milling cutters for roughing, finishing and trochoidal milling as well as milling cutters for engraving and deburring complete the range.

High precision

The tools are characterised by excellent dimensional accuracy and maximum precision. This enables the process-reliable realisation of complex 3D contours with low tolerance specifications.

Ball nose milling cutter	Corner radius milling cutters	Circle radius milling cutter	High-feed milling cutters
			
<p>High precision machining of 3D contours</p> <ul style="list-style-type: none"> - Solid carbide milling cutters with a high level of radius accuracy - Available in cylindrical and conical forms - For a wide range of materials - Variety of dimensions for hard and soft machining of steel - Different numbers of teeth available <p>Ø area: 0.10 - 20.00 mm</p> <p>P M K N H</p>	<p>Milling with a very precise corner radius</p> <ul style="list-style-type: none"> - Finishing of 3D moulds - High precision solid carbide milling cutters with a high level of radius accuracy - For a wide range of materials - Variety of dimensions for hard and soft machining of steel - Different numbers of teeth available <p>Ø area: 0.10 - 20.00 mm</p> <p>P M K N H</p>	<p>Milling with a large operating radius</p> <ul style="list-style-type: none"> - Finishing of complex free-form surfaces and complicated workpiece geometries - Higher axial material removal rate with a much better surface finish compared to a full radius milling cutter - Short machining time due to large line interlacing - Available in teardrop form and taper shape <p>Ø area: 2.00 - 12.00 mm</p> <p>P M K N H</p>	<p>Milling at high feed rates</p> <ul style="list-style-type: none"> - Perfect for high-feed machining with a high material removal rate and high process reliability - Different numbers of teeth available - Extremely quiet running - High process reliability thanks to innovative face geometry - For the hard and soft machining of steel in particular <p>Ø area: 2.00 - 16.00 mm</p> <p>P M K S H</p>
<p>Page 31</p>	<p>Page 79</p>	<p>Page 141</p>	<p>Page 151</p>









Shoulder milling cutters	Trochoidal milling cutters	Engraving and deburring	Special solutions
			
<p>Roughing, finishing, ramping and groove milling</p> <ul style="list-style-type: none"> - Perfect for roughing, finishing and milling pockets - For 2D/2.5D machining - Very long tool life achievable - Excellent dimensional accuracy - Designs available with different lengths - For a wide range of applications and materials <p>Ø area: 2.50 - 25.00 mm</p> <p>P M K N H</p>	<p>Trochoidal milling</p> <ul style="list-style-type: none"> - Maximum material removal rate while providing high surface quality at the same time - Pre-machining and fine machining with one tool - Cutting depth up to 5xD - Extra long cutting tool - Optimised unequal spacing and finely balanced cutting tool for protecting the machine spindle and a longer tool life - Chip breaker for optimum chip control <p>Ø area: 4.00 - 20.00 mm</p> <p>P M K H</p>	<p>Chamfer and deburring milling cutters, engravers</p> <ul style="list-style-type: none"> - Economic chamfering and deburring of pre-machined parts - Engravers for engraving fonts and contours and for copy milling - Drill milling cutter for combination machining in one machining step, especially for sheet metal and thin-walled parts <p>Ø area: 3.00 - 20.00 mm</p> <p>P M K N S H</p>	<p>Custom tools made to order</p> <p>Customer-specific custom tools made from solid carbide to meet the highest requirements.</p> <ul style="list-style-type: none"> - Individual lengths - Tools with conical and cylindrical working depths
<p>Page 163</p>	<p>Page 213</p>	<p>Page 227</p>	









SELECTING A MILLING CUTTER

Step-by-step guide to selecting the right milling cutter

Say you're looking for a ball nose milling cutter for machining a part with a 3° draft made of hardened steel with 52 HRC. This selection guide explains how to choose the right milling cutter step by step.

1	Application	Select the type of milling cutter you need.	➤		Ball nose milling cutter		Corner radius milling cutter
2	Material suitability	Select your workpiece according to the MAPAL machining groups (MMG). You'll find the MMG chart on the fold-out page at the end of the catalogue.	➤		Steel		Stainless steel
3	Design	Select your preferred design or the desired cutting edge design.	➤		Without neck		With neck Cylindrical
4	Additional geometric features	Check that the geometric features meet your requirements.	➤	Diameter range	Number of teeth		
5	Product	Select the milling cutter you need. Products of the preferred series are in stock and available at short notice, while products with configurable features can be freely configured within predefined limits.	➤				











 Circle radius milling cutter	 High-feed milling cutter	 Shoulder milling cutter	 Trochoidal milling cutter	 Engraving and deburring
K Cast iron	N Non-ferrous metals and plastics	C Composite materials	S Super alloy and titanium	H Hardened steel and cast steel
 With neck Conical	 45° chamfer	 90° Sharp-edged	 Corner radius	

Cutting material

 Product with configurable features

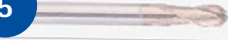
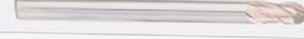
DIE & MOULD | Milling with solid carbide and PCD 21

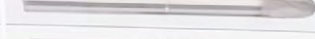
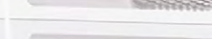
Step 1: Application 
 Step 2: Material suitability 
 Step 3: Design 

Features			Product			
\varnothing [mm]	z	Mat.	Product name	Specification		Page
0,1 - 16	2	SC	OptiMill-3D-BN	MBN100 - 102		32
3 - 16	4	SC	OptiMill-3D-BN	MBN103 - 105		39
0,1 - 16	2	SC	OptiMill-3D-BN-Hardened	MBN106, 107		43
3 - 16	4	SC	OptiMill-3D-BN-Hardened	MBN108, 109		47
0,2 - 10	2	DC	OptiMill-3D-BN-Graphite	MBN110		50
3 - 12	3	DC	OptiMill-3D-BN-Graphite	MBN111		52
4 - 16	MT	DC	OptiMill-3D-BN-Graphite-MT	MBN112		53
3 - 12	2	PCD	OptiMill-Diamond-Radius	SHM521		54



Ball nose milling cutter

Material suitability															Design						
P	M	K	N				C	S					H								
1-6	1-3	1-3	1	2	3	4	1-6	1	2	3	4	5	1.1	1.2	2.1	2.2	2.3	3.1			
■	▣	■											■	■	▣				✓	✓	✓
■	▣	■											■	■	▣				✓	✓	✓
▣	■	▣											■	■	■	■	■	■	✓	✓	
▣	■	▣											■	■	■	■	■	■	✓	✓	
					■															✓	
					■															✓	
					■														✓		
			■	■	▣	▣		▣												✓	
			■	▣															✓	✓	
			▣	■															✓		



Corner radius milling cutter

Material suitability															Design						
P	M	K	N				C	S					H								
1-6	1-3	1-3	1	2	3	4	1-6	1	2	3	4	5	1.1	1.2	2.1	2.2	2.3	3.1			
■	▣	■											■	■	▣				✓	✓	✓
■	▣	■											■	■	▣				✓	✓	✓
▣	■	▣											■	■	■	■	■	■	✓	✓	
▣	■	▣											■	■	■	■	■	■	✓	✓	
▣	■	▣											■	■	■	■	■	■		✓	
					■															✓	
					■															✓	
					■															✓	
			■	■	▣	▣		▣													✓
			■	▣															✓	✓	
			▣	■															✓	✓	

■ highly suitable

▣ suitable in some situations

Step 1:
Application



Step 2:
Material suitability



Step 3:
Design



	Features			Product			
	∅ [mm]	z	Mat.	Product name	Specification		Page
	0,1 - 16	2	SC	OptiMill-3D-BN	MBN100 - 102		32
	3 - 16	4	SC	OptiMill-3D-BN	MBN103 - 105		39
	0,1 - 16	2	SC	OptiMill-3D-BN-Hardened	MBN106, 107		43
	3 - 16	4	SC	OptiMill-3D-BN-Hardened	MBN108, 109		47
	0,2 - 10	2	DC	OptiMill-3D-BN-Graphite	MBN110		50
	3 - 12	3	DC	OptiMill-3D-BN-Graphite	MBN111		52
	4 - 16	MT	DC	OptiMill-3D-BN-Graphite-MT	MBN112		53
	3 - 12	2	PCD	OptiMill-Diamond-Radius	SHM521		54
	1 - 20	2	SC	OptiMill-3D-BN-Alu	MBN114 - 116		55
	1 - 16	2	SC	OptiMill-3D-BN-Copper	MBN113		59

	Features			Product			
	∅ [mm]	z	Mat.	Product name	Specification		Page
	0,1 - 12	2	SC	OptiMill-3D-CR	MCR100 - 102		80
	3 - 12	4	SC	OptiMill-3D-CR	MCR103 - 105		90
	0,1 - 12	2	SC	OptiMill-3D-CR-Hardened	MCR106, 107		97
	3 - 12	4	SC	OptiMill-3D-CR-Hardened	MCR108, 109		102
	4 - 12	5	SC	OptiMill-3D-CR-Hardened	MCR110		105
	0,4 - 4	2	DC	OptiMill-3D-CR-Graphite	MCR111, 112		106
	3 - 12	3	DC	OptiMill-3D-CR-Graphite	MCR113, 114		108
	4 - 12	4	DC	OptiMill-3D-CR-Graphite	MCR115, 116		110
	3 - 10	2	PCD	OptiMill-Diamond-Torus	SHM551		111
	2 - 20	2	SC	OptiMill-3D-CR-Alu	MCR119, 120		112
	1 - 20	2	SC	OptiMill-3D-CR-Copper	MCR117, 118		114



Circle radius milling cutter

Material suitability															Design							
P	M	K	N				C	S					H									
1-6	1-3	1-3	1	2	3	4	1-6	1	2	3	4	5	1.1	1.2	2.1	2.2	2.3	3.1				
■	▣	■	■	■									■	■	▣					✓		
■	▣	■	■	■									■	■	▣					✓		



High-feed milling cutter

Material suitability															Design							
P	M	K	N				C	S					H									
1-6	1-3	1-3	1	2	3	4	1-6	1	2	3	4	5	1.1	1.2	2.1	2.2	2.3	3.1				
■	▣	■							▣	▣			■	■	▣						✓	
■		■											■	■	▣						✓	
▣		▣											■	■	■	■	■	■			✓	
▣		▣											▣	▣	■	■	■	■			✓	

■ highly suitable

▣ suitable in some situations

Step 1:
Application









Step 2:
Material suitability



Step 3:
Design



	Features			Product			
	\emptyset [mm]	z	Mat.	Product name	Specification		Page
	2 - 12	3 / 4	SC	OptiMill-3D-CS, teardrop form	MCS100		144
	6 - 12	3	SC	OptiMill-3D-CS, taper shape	MCS101		145

	Features			Product			
	\emptyset [mm]	z	Mat.	Product name	Specification		Page
	2 - 16	3	SC	OptiMill-3D-HF	MHF100		152
	3 - 16	4	SC	OptiMill-3D-HF	MHF101		153
	2 - 16	4	SC	OptiMill-3D-HF-Hardened	MHF102		154
	6 - 16	6	SC	OptiMill-3D-HF-Hardened	MHF103		155



Shoulder milling cutter

Material suitability															Edge design							
P	M	K	N				C	S					H						45°	90°	CR	
1-6	1-3	1-3	1	2	3	4	1-6	1	2	3	4	5	1.1	1.2	2.1	2.2	2.3	3.1				
■	■	■																		✓		✓
■	■	■						■	■											✓	✓	
■	■	■																		✓		
■	■	■																				✓
			■	■			■															✓
			■	■			■															✓
■	■	■											■	■	■							✓
■	■	■											■	■	■	■	■	■			✓	✓
					■																✓	
			■	■	■		■	■												✓		



Trochoidal milling cutter

Material suitability															Edge design							
P	M	K	N				C	S					H						45°	90°	CR	
1-6	1-3	1-3	1	2	3	4	1-6	1	2	3	4	5	1.1	1.2	2.1	2.2	2.3	3.1				
■	■	■																		✓		
■	■	■																		✓		
													■	■	■	■	■	■				✓



Engraving and deburring

Material suitability															Edge design							
P	M	K	N				C	S					H						45°	90°	CR	
1-6	1-3	1-3	1	2	3	4	1-6	1	2	3	4	5	1.1	1.2	2.1	2.2	2.3	3.1				
■	■	■	■	■					■		■			■	■	■						
■	■	■	■	■																✓		

■ highly suitable

■ suitable in some situations

Step 1:
Application













Step 2:
Material suitability

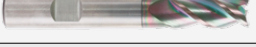
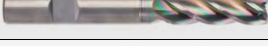
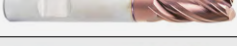

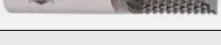
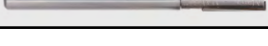
Step 3:
Design



	Features			Product			
	\emptyset [mm]	z	Mat.	Product name	Specification		Page
	2,5 - 25	4	SC	OptiMill-Uni-HPC-Plus	SCM720, 740, 760, 770		164
	4 - 20	7	SC	OptiMill-Uni-HPC-Finish	SCM830		172
	4 - 25	5	SC	OptiMill-Uni-Wave	SCM880, 890, 900, 910		175
	3,8 - 20	3	SC	OptiMill-Uni-HPC-Pocket	SCM800, 810, 840		180
	5 - 20	3	SC	OptiMill-Alu-HPC-Pocket	SCM850		184
	5 - 20	4	SC	OptiMill-Alu-HPC-Pocket	SCM854		185
	4 - 20	4	SC	OptiMill-Hardened	SCM102, 103		186
	4 - 20	6	SC	OptiMill-Hardened-Finish	SCM104, 124		188
	3 - 12	MT	DC	OptiMill-Graphite-MT	SCM105, 106		193
	3 - 12	2	PCD	OptiMill-Diamond-Typ 51	SHM511, 611, 711		195

	Features			Product			
	\emptyset [mm]	z	Mat.	Product name	Specification		Page
	4 - 20	5	SC	OptiMill-Tro-Uni	SCM580, 940		214
	4 - 20	7	SC	OptiMill-Tro-PM	SCM820, 930		217
	6 - 20	5	SC	OptiMill-Tro-H	SCM920		221

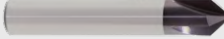
	Features			Product			
	\emptyset [mm]	z	Mat.	Product name	Specification		Page
	3 - 8	1	SC	OptiMill-Graver	SCM107		228
	4 - 20	4	SC	OptiMill-Chamfer	SCM340		229

Product ID codes

End milling cutter for the die & mould sector



Type of milling cutter

MBN	Ball nose milling cutter Die Et Mould – Ball Nose
MCR	Corner radius milling cutter Die Et Mould – corner radius
MCS	Circle radius milling cutter Die Et Mould – circle segment
MHF	High-feed milling cutter Die Et Mould – high feed

Tool diameter x 0.1 mm

040	Milling cutter $\varnothing = 4.0$ mm
...	...

Radius x 0.01 mm

0050	Radius = 0.5 mm
Radius x 0.1 mm	
PR _{CAM} for milling cutter type "MHF"	

Series

100	Continuous
101	
...	
999	

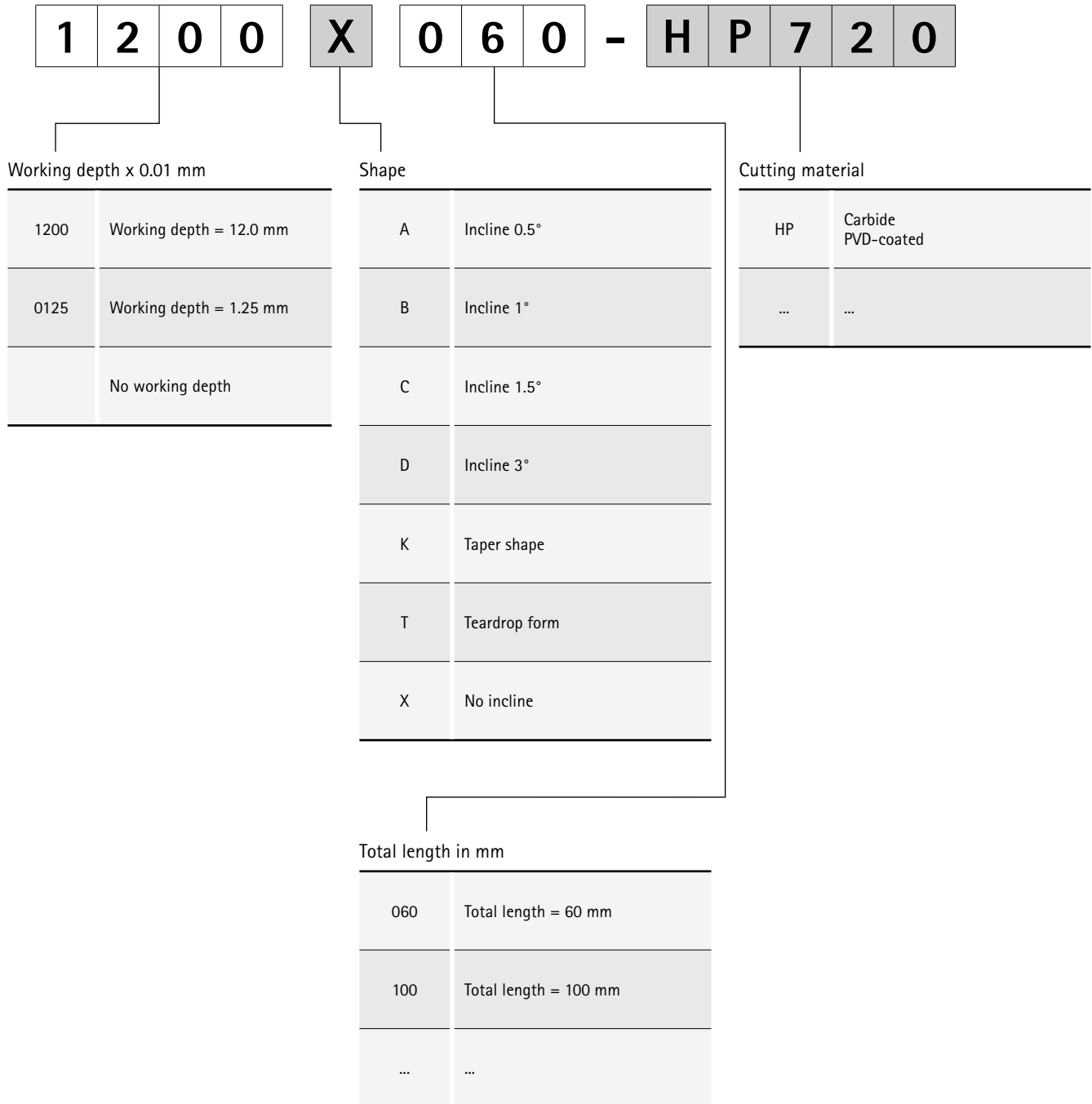

Product ID codes

Solid carbide and PCD end milling cutter

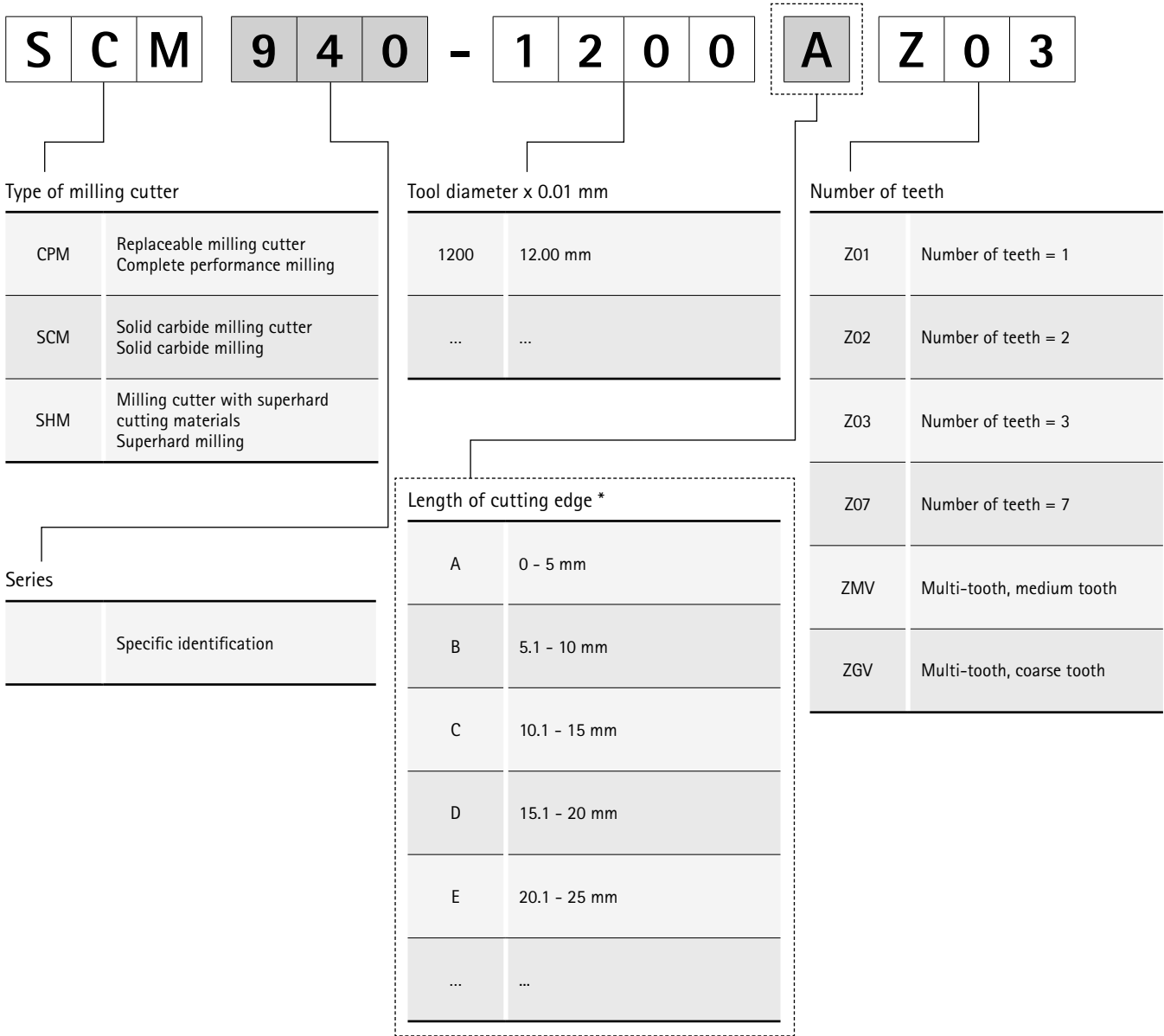

* Only with milling cutter type SHM

** Not applicable for milling cutter type CPM

*** For milling cutter type CPM, the shank form corresponds to the CFS connection size

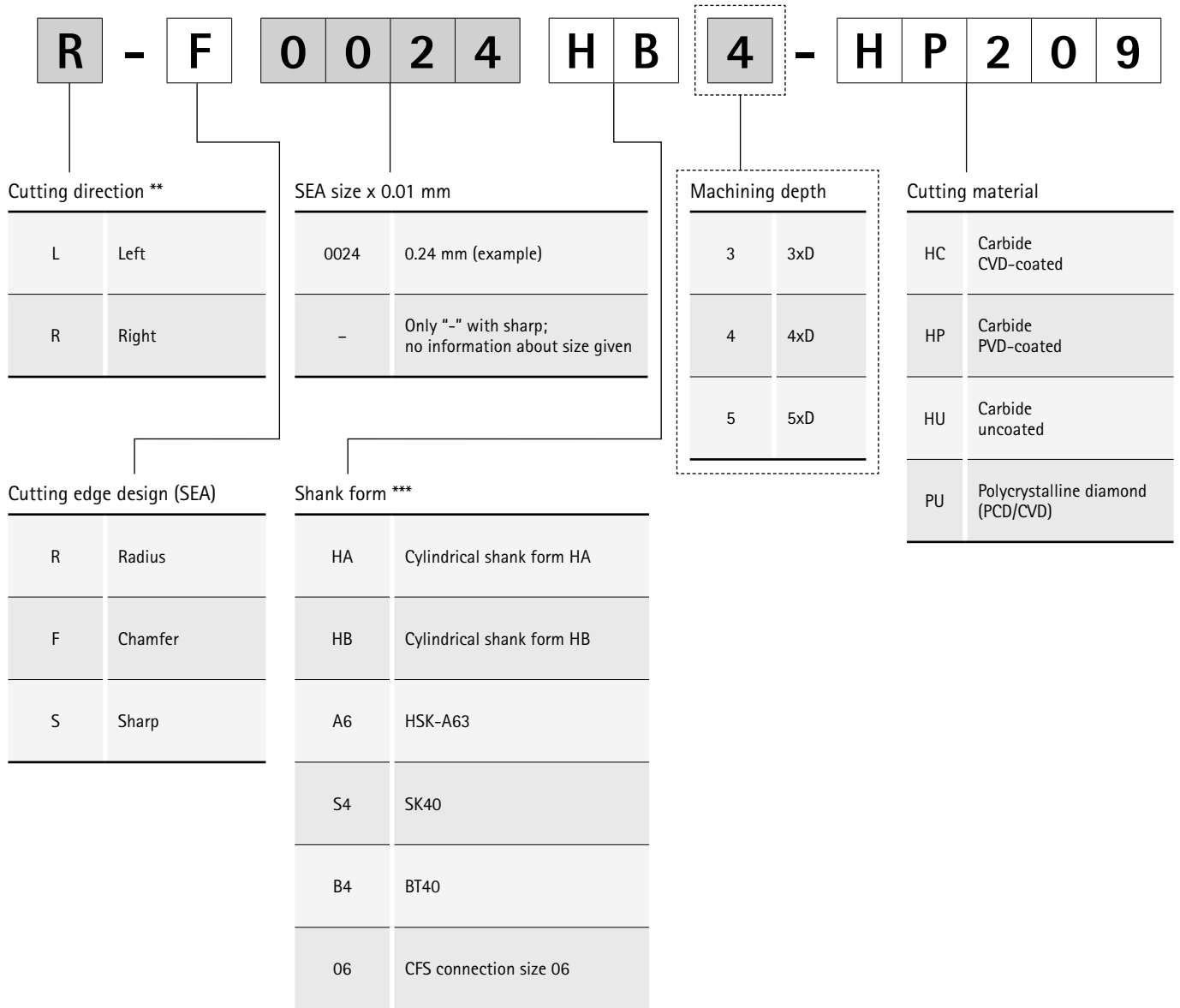

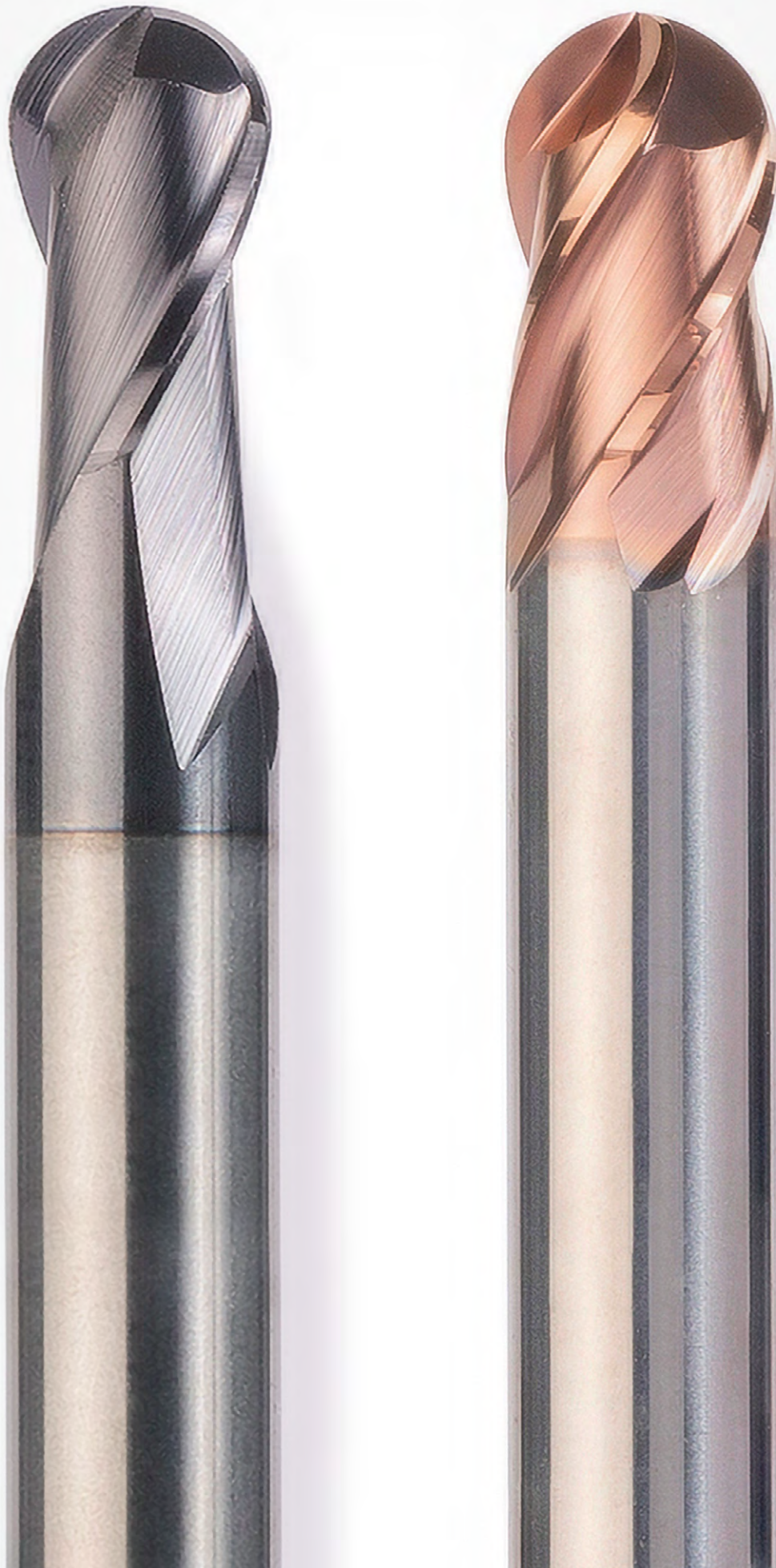

BALL NOSE MILLING CUTTER

Steel, stainless steel and cast iron

OptiMill-3D-BN, z=2	32
OptiMill-3D-BN, design with neck, z=2	33
OptiMill-3D-BN, conical design, z=2	36
OptiMill-3D-BN, z=4	39
OptiMill-3D-BN, design with neck, z=4	40
OptiMill-3D-BN, conical design, z=4	41

Hardened steel

OptiMill-3D-BN-Hardened, z=2	43
OptiMill-3D-BN-Hardened, design with neck, z=2	44
OptiMill-3D-BN-Hardened, z=4	47
OptiMill-3D-BN-Hardened, design with neck, z=4	48

Graphite, aluminium and copper

OptiMill-3D-BN-Graphite, design with neck, z=2	50
OptiMill-3D-BN-Graphite, design with neck, z=3	52
OptiMill-3D-BN-Graphite-MT, multi-tooth	53
OptiMill-Diamond-Radius	54
OptiMill-3D-BN-Alu, short design, z=2	55
OptiMill-3D-BN-Alu, long design, z=2	56
OptiMill-3D-BN-Alu, design with neck, z=2	57
OptiMill-3D-BN-Copper, z=2	59
PCD full head milling cutter	60

Technical appendix

Cutting data recommendation	62
Determination of cutting data working depth	548

OptiMill®-3D-BN

Ball nose milling cutter, z=2
MBN100

Design:

Diameter of milling cutter: 6.00 - 12.00 mm
 Cutting material: HP801
 Number of cutting edges: 2
 Helix angle: 28°
 Radial contour tolerance: ±0.005 if $d_1 \leq 6$ mm
 ±0.01 if $d_1 > 6$ mm

Application:

Suitable for machining workpiece materials up to 55 HRC.

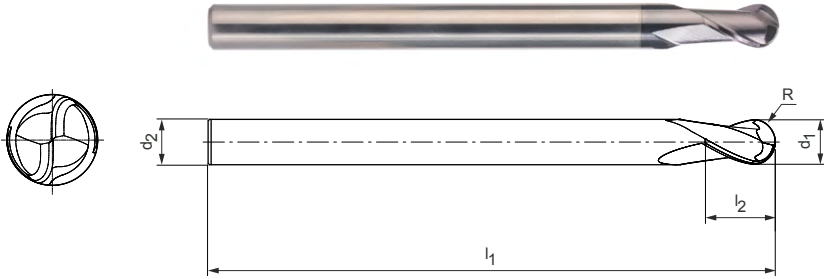

Preferred series in stock

Dimensions					z	Specification	Order no.
d ₁	R	d ₂ h5	l ₁	l ₂			
6,00	3	6	60	6,9	2	MBN100-060-0300-X060-HP801	31153242
6,00	3	6	100	6,9	2	MBN100-060-0300-X100-HP801	31153243
8,00	4	8	64	9,2	2	MBN100-080-0400-X064-HP801	31153244
8,00	4	8	75	9,2	2	MBN100-080-0400-X075-HP801	31354891
8,00	4	8	100	9,2	2	MBN100-080-0400-X100-HP801	31153245
10,00	5	10	75	11,5	2	MBN100-100-0500-X075-HP801	31153246
10,00	5	10	120	11,5	2	MBN100-100-0500-X120-HP801	31153247
12,00	6	12	75	13,8	2	MBN100-120-0600-X075-HP801	31153248
12,00	6	12	120	13,8	2	MBN100-120-0600-X120-HP801	31153249

Dimensions in mm.

For cutting data recommendations, see end of chapter.

Special designs and other coatings available upon request.

OptiMill®-3D-BN

Ball nose milling cutter, design with neck, z=2
MBN101

Design:

Diameter of milling cutter: 0.10 - 12.00 mm
Cutting material: HP801/HP817/HP820
Number of cutting edges: 2
Helix angle: 28°
Radial contour tolerance: ±0.005 if $d_1 \leq 6$ mm
±0.01 if $d_1 > 6$ mm

Application:

Suitable for machining workpiece materials up to 55 HRC.

Shank transition:

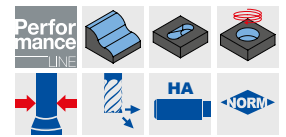
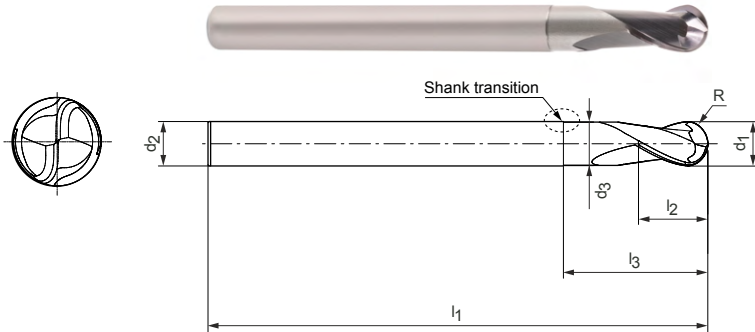
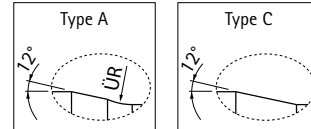

Preferred series in stock

Dimensions							Working depth at x° incline				Type	Specification	Order no.
d ₁	R	l ₃	d ₂ h5	l ₁	l ₂	d ₃	0.5°	1°	1.5°	3°			
0,40	0,2	0,75	4	50	0,5	0,37	1,05	1,10	1,15	1,28	A	MBN101-004-0020-0075X050-HP820	31153272
0,50	0,25	1,5	4	50	0,6	0,46	1,87	1,94	2,01	2,19	A	MBN101-005-0025-0150X050-HP820	31153278
0,50	0,25	2	4	50	0,6	0,46	2,39	2,48	2,56	2,77	A	MBN101-005-0025-0200X050-HP820	31153279
0,50	0,25	3	4	50	0,6	0,46	3,43	3,55	3,65	4,03	A	MBN101-005-0025-0300X050-HP820	31153280
0,50	0,25	4	4	50	0,6	0,46	4,47	4,61	4,73	5,35	A	MBN101-005-0025-0400X050-HP820	31153281
0,50	0,25	4	6	60	0,6	0,46	4,47	4,61	4,73	5,35	A	MBN101-005-0025-0400X060-HP820	31153282
0,60	0,3	2	4	50	0,7	0,56	2,39	2,48	2,56	2,76	A	MBN101-006-0030-0200X050-HP820	31153283
0,60	0,3	3	4	50	0,7	0,56	3,43	3,55	3,65	4,01	A	MBN101-006-0030-0300X050-HP820	31153284
0,60	0,3	4	4	50	0,7	0,56	4,47	4,61	4,72	5,34	A	MBN101-006-0030-0400X050-HP820	31153285
0,60	0,3	4	6	60	0,7	0,56	4,47	4,61	4,72	5,34	A	MBN101-006-0030-0400X060-HP820	31153286
0,60	0,3	5	4	50	0,7	0,56	5,51	5,66	5,79	6,67	A	MBN101-006-0030-0500X050-HP820	31153287
0,80	0,40	3	4	50	0,9	0,760	3,43	3,54	3,64	3,98	A	MBN101-008-0040-0300X050-HP820	31153288
0,80	0,40	4	4	50	0,9	0,760	4,47	4,60	4,72	5,31	A	MBN101-008-0040-0400X050-HP820	31153289
0,80	0,40	6	4	50	0,9	0,760	6,54	6,71	6,89	7,96	A	MBN101-008-0040-0600X050-HP820	31153290
0,80	0,40	6	6	60	0,9	0,760	6,54	6,71	6,89	7,96	A	MBN101-008-0040-0600X060-HP820	31153291
1,00	0,5	3	4	50	1,2	0,94	3,47	3,57	3,66	4,01	A	MBN101-010-0050-0300X050-HP820	31153292
1,00	0,5	4	4	50	1,2	0,94	4,51	4,63	4,74	5,34	A	MBN101-010-0050-0400X050-HP820	31153293
1,00	0,5	5	4	50	1,2	0,94	5,54	5,68	5,80	6,66	A	MBN101-010-0050-0500X050-HP820	31153294
1,00	0,5	6	4	50	1,2	0,94	6,57	6,73	6,93	7,99	A	MBN101-010-0050-0600X050-HP820	31153295
1,00	0,5	8	4	50	1,2	0,94	8,63	8,83	9,22	10,65	A	MBN101-010-0050-0800X050-HP820	31153296
1,00	0,5	10	4	50	1,2	0,94	10,68	11,00	11,50	13,30	A	MBN101-010-0050-1000X050-HP820	31153297
1,00	0,5	10	6	60	1,2	0,94	10,68	11,00	11,50	13,30	A	MBN101-010-0050-1000X060-HP820	31153298
1,50	0,75	5	4	50	1,7	1,44	5,53	5,67	5,79	6,58	A	MBN101-015-0075-0500X050-HP817	31153299
1,50	0,75	6	4	50	1,7	1,44	6,56	6,72	6,90	7,91	A	MBN101-015-0075-0600X050-HP817	31153300
1,50	0,75	8	4	50	1,7	1,44	8,62	8,81	9,18	10,57	A	MBN101-015-0075-0800X050-HP817	31153301
1,50	0,75	10	4	50	1,7	1,44	10,67	10,98	11,46	13,22	A	MBN101-015-0075-1000X050-HP817	31153302
1,50	0,75	10	6	60	1,7	1,44	10,67	10,98	11,46	13,22	A	MBN101-015-0075-1000X060-HP817	31153303
1,50	0,75	12	4	50	1,7	1,44	12,72	13,16	13,74	15,88	A	MBN101-015-0075-1200X050-HP817	31153304
1,50	0,75	12	6	60	1,7	1,44	12,72	13,16	13,74	15,88	A	MBN101-015-0075-1200X060-HP817	31153305
1,50	0,75	15	4	50	1,7	1,44	15,79	16,43	17,16	19,86	A	MBN101-015-0075-1500X050-HP817	31153306
1,50	0,75	15	6	60	1,7	1,44	15,79	16,43	17,16	19,86	A	MBN101-015-0075-1500X060-HP817	31153307
1,80	0,9	6	4	50	2,1	1,74	6,56	6,71	6,88	7,86	A	MBN101-018-0090-0600X050-HP817	31153308
1,80	0,9	8	4	50	2,1	1,74	8,62	8,80	9,16	10,52	A	MBN101-018-0090-0800X050-HP817	31153309
1,80	0,9	10	4	50	2,1	1,74	10,67	10,97	11,44	13,17	A	MBN101-018-0090-1000X050-HP817	31153310
1,80	0,9	15	4	50	2,1	1,74	15,78	16,42	17,14	19,81	A	MBN101-018-0090-1500X050-HP817	31153311

OptiMill®-3D-BN | MBN101 | Ball nose milling cutter, design with neck, z=2

Dimensions							Working depth at x° incline				Type	Specification	Order no.
d ₁	R	l ₃	d ₂ h5	l ₁	l ₂	d ₃	0.5°	1°	1.5°	3°			
2,00	1	6	4	50	2,3	1,94	6,99	7,29	7,54	8,17	A	MBN101-020-0100-0600X050-HP801	31153312
2,00	1	8	4	50	2,3	1,94	9,09	9,45	9,74	10,49	A	MBN101-020-0100-0800X050-HP801	31153313
2,00	1	10	4	50	2,3	1,94	11,19	11,59	11,92	13,14	A	MBN101-020-0100-1000X050-HP801	31153314
2,00	1	12	4	50	2,3	1,94	13,28	13,72	14,08	15,80	A	MBN101-020-0100-1200X050-HP801	31153315
2,00	1	15	4	50	2,3	1,94	16,39	16,90	17,30	19,78	A	MBN101-020-0100-1500X050-HP801	31153316
2,00	1	15	6	60	2,3	1,94	16,39	16,90	17,30	19,78	A	MBN101-020-0100-1500X060-HP801	31153317
2,00	1	18	4	50	2,3	1,94	19,50	20,05	20,55	22,85	A	MBN101-020-0100-1800X050-HP801	31153318
2,00	1	20	4	50	2,3	1,94	21,57	22,15	22,83	24,85	A	MBN101-020-0100-2000X050-HP801	31153319
2,00	1	20	6	75	2,3	1,94	21,57	22,15	22,83	26,41	A	MBN101-020-0100-2000X075-HP801	31153320
2,50	1,3	8	4	50	2,9	2,44	9,08	9,43	9,72	10,43	A	MBN101-025-0125-0800X050-HP801	31153321
2,50	1,3	10	4	50	2,9	2,44	11,18	11,58	11,90	13,06	A	MBN101-025-0125-1000X050-HP801	31153322
2,50	1,3	15	4	50	2,9	2,44	16,39	16,88	17,28	18,67	A	MBN101-025-0125-1500X050-HP801	31153323
2,50	1,25	15	6	60	2,9	2,440	16,39	16,88	17,28	19,70	A	MBN101-025-0125-1500X060-HP801	31153324
2,50	1,25	20	4	50	2,9	2,440	21,56	22,14	22,80	23,67	A	MBN101-025-0125-2000X050-HP801	31153325
2,50	1,25	20	6	60	2,9	2,440	21,56	22,14	22,80	26,33	A	MBN101-025-0125-2000X060-HP801	31153326
2,50	1,25	25	6	75	2,9	2,440	26,72	27,37	28,50	32,97	A	MBN101-025-0125-2500X075-HP801	31153328
3,00	1,5	10	6	60	3,5	2,94	11,17	11,56	11,88	12,98	A	MBN101-030-0150-1000X060-HP801	31153329
3,00	1,5	15	6	60	3,5	2,94	16,38	16,87	17,26	19,62	A	MBN101-030-0150-1500X060-HP801	31153330
3,00	1,5	20	6	60	3,5	2,94	21,56	22,13	22,76	26,25	A	MBN101-030-0150-2000X060-HP801	31153331
3,00	1,5	25	6	75	3,5	2,94	26,71	27,36	28,47	32,20	A	MBN101-030-0150-2500X075-HP801	31153332
4,00	2	10	6	60	4,6	3,94	11,14	11,52	11,84	12,82	A	MBN101-040-0200-1000X060-HP801	31153333
4,00	2	15	6	60	4,6	3,94	16,36	16,84	17,23	19,46	A	MBN101-040-0200-1500X060-HP801	31153334
4,00	2	20	6	60	4,6	3,94	21,54	22,10	22,69	24,85	A	MBN101-040-0200-2000X060-HP801	31153335
4,00	2	25	6	75	4,6	3,94	26,70	27,33	28,40	29,85	A	MBN101-040-0200-2500X075-HP801	31153336
4,00	2	30	6	75	4,6	3,94	31,84	32,66	34,10	34,85	A	MBN101-040-0200-3000X075-HP801	31153337
4,00	2	35	6	75	4,6	3,94	36,98	38,11	39,80	39,85	A	MBN101-040-0200-3500X075-HP801	31153338
5,00	2,50	15	6	60	5,8	4,90	15,78	16,38	17,03	17,59	C	MBN101-050-0250-1500X060-HP801	31153339
5,00	2,50	20	6	60	5,8	4,90	21,00	21,82	22,59	-	C	MBN101-050-0250-2000X060-HP801	31153340
5,00	2,50	25	6	60	5,8	4,90	26,21	27,27	27,59	-	C	MBN101-050-0250-2500X060-HP801	31153341
5,00	2,50	30	6	75	5,8	4,90	31,42	32,59	-	-	C	MBN101-050-0250-3000X075-HP801	31153342
6,00	3	15	6	60	6,9	5,90	-	-	-	-	-	MBN101-060-0300-1500X060-HP801	31153343
6,00	3	20	6	60	6,9	5,90	-	-	-	-	-	MBN101-060-0300-2000X060-HP801	31153344
6,00	3	25	6	60	6,9	5,90	-	-	-	-	-	MBN101-060-0300-2500X060-HP801	31153345
6,00	3	30	6	75	6,9	5,90	-	-	-	-	-	MBN101-060-0300-3000X075-HP801	31153346
6,00	3	35	6	75	6,9	5,90	-	-	-	-	-	MBN101-060-0300-3500X075-HP801	31153347
8,00	4	25	8	64	9,2	7,80	-	-	-	-	-	MBN101-080-0400-2500X064-HP801	31153348
8,00	4	50	8	100	9,2	7,80	-	-	-	-	-	MBN101-080-0400-5000X100-HP801	31153349
10,00	5	30	10	75	11,5	9,80	-	-	-	-	-	MBN101-100-0500-3000X075-HP801	31153350
10,00	5	50	10	100	11,5	9,80	-	-	-	-	-	MBN101-100-0500-5000X100-HP801	31153351
12,00	6	35	12	75	13,8	11,80	-	-	-	-	-	MBN101-120-0600-3500X075-HP801	31153352
12,00	6	60	12	100	13,8	11,80	-	-	-	-	-	MBN101-120-0600-6000X100-HP801	31153353

Available on request

0,10	0,05	0,3	4	50	0,1	0,075	0,56	0,60	0,63	0,74	A	MBN101-001-0005-0030X050-HP820	31153252
0,10	0,05	0,3	6	60	0,1	0,075	0,56	0,60	0,63	0,74	A	MBN101-001-0005-0030X060-HP820	31153253
0,10	0,05	0,4	4	50	0,1	0,075	0,67	0,71	0,75	0,87	A	MBN101-001-0005-0040X050-HP820	31153254
0,10	0,05	0,4	6	60	0,1	0,075	0,67	0,71	0,75	0,87	A	MBN101-001-0005-0040X060-HP820	31153255
0,20	0,1	0,5	4	50	0,2	0,17	0,79	0,83	0,87	0,99	A	MBN101-002-0010-0050X050-HP820	31153256
0,20	0,1	0,5	6	60	0,2	0,17	0,79	0,83	0,87	0,99	A	MBN101-002-0010-0050X060-HP820	31153257
0,20	0,1	0,75	4	50	0,2	0,17	1,05	1,11	1,16	1,30	A	MBN101-002-0010-0075X050-HP820	31153258
0,20	0,1	1	4	50	0,2	0,17	1,32	1,39	1,45	1,61	A	MBN101-002-0010-0100X050-HP820	31153259
0,20	0,1	1	6	60	0,2	0,17	1,32	1,39	1,45	1,61	A	MBN101-002-0010-0100X060-HP820	31153260
0,20	0,1	1,25	4	50	0,2	0,17	1,58	1,66	1,73	1,90	A	MBN101-002-0010-0125X050-HP820	31153261
0,20	0,1	1,5	4	50	0,2	0,17	1,85	1,93	2,01	2,20	A	MBN101-002-0010-0150X050-HP820	31153262
0,20	0,1	1,5	6	60	0,2	0,17	1,85	1,93	2,01	2,20	A	MBN101-002-0010-0150X060-HP820	31153263
0,30	0,15	0,5	4	50	0,3	0,27	0,79	0,83	0,87	0,98	A	MBN101-003-0015-0050X050-HP820	31153264

OptiMill®-3D-BN | MBN101 | Ball nose milling cutter, design with neck, z=2

Dimensions							Working depth at x° incline				Type	Specification	Order no.
d ₁	R	l ₃	d ₂ h5	l ₁	l ₂	d ₃	0.5°	1°	1.5°	3°			
0,30	0,15	0,75	4	50	0,3	0,27	1,05	1,10	1,15	1,29	A	MBN101-003-0015-0075X050-HP820	31153265
0,30	0,15	1	4	50	0,3	0,27	1,32	1,38	1,44	1,60	A	MBN101-003-0015-0100X050-HP820	31153266
0,30	0,15	1	6	60	0,3	0,27	1,32	1,38	1,44	1,60	A	MBN101-003-0015-0100X060-HP820	31153267
0,30	0,15	1,25	4	50	0,3	0,27	1,58	1,65	1,72	1,89	A	MBN101-003-0015-0125X050-HP820	31153268
0,30	0,15	1,5	4	50	0,3	0,27	1,84	1,93	2,00	2,19	A	MBN101-003-0015-0150X050-HP820	31153269
0,30	0,15	1,5	6	60	0,3	0,27	1,84	1,93	2,00	2,19	A	MBN101-003-0015-0150X060-HP820	31153270
0,30	0,15	2	6	60	0,3	0,27	2,37	2,47	2,55	2,77	A	MBN101-003-0015-0200X060-HP820	31153271
0,40	0,2	1	4	50	0,5	0,37	1,31	1,38	1,43	1,59	A	MBN101-004-0020-0100X050-HP820	31153273
0,40	0,2	1,5	4	50	0,5	0,37	1,84	1,92	1,99	2,18	A	MBN101-004-0020-0150X050-HP820	31153274
0,40	0,2	2	4	50	0,5	0,37	2,37	2,46	2,55	2,76	A	MBN101-004-0020-0200X050-HP820	31153275
0,40	0,2	2	6	60	0,5	0,37	2,37	2,46	2,55	2,76	A	MBN101-004-0020-0200X060-HP820	31153276
0,40	0,2	3	6	60	0,5	0,37	3,41	3,54	3,64	4,01	A	MBN101-004-0020-0300X060-HP820	31153277

Dimensions in mm.

For cutting data recommendations, see end of chapter.

Special designs and other coatings available upon request.

OptiMill®-3D-BN

Ball nose milling cutter, conical design, z=2
MBN102

Design:

Diameter of milling cutter: 0.80 - 12.00 mm
Cutting material: HP801/HP820
Number of cutting edges: 2
Helix angle: 28°
Radial contour tolerance: ±0.005 if $d_1 \leq 6$ mm
±0.01 if $d_1 > 6$ mm

Application:

Suitable for machining workpiece materials up to 55 HRC.

Shank transition:

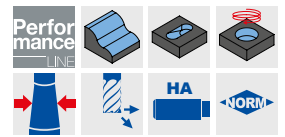
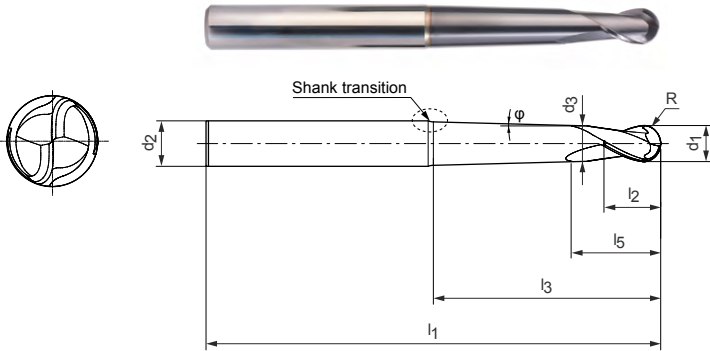
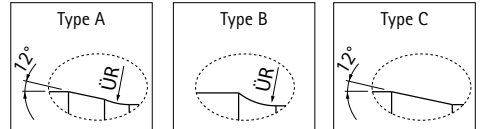

Preferred series in stock

Dimensions									Working depth at x° incline				Type	Specification	Order no.
d ₁	R	φ [°]	l ₃	d ₂ h5	l ₁	l ₂	d ₃	l ₅	0.5°	1°	1.5°	3°			
0,80	0,4	0,5	6	6	60	0,9	0,76	1,6	6,37	6,59	6,76	7,72	A	MBN102-008-0040-0600A060-HP820	31153356
0,80	0,4	0,5	8	6	60	0,9	0,76	1,6	8,37	8,65	8,88	10,27	A	MBN102-008-0040-0800A060-HP820	31153357
0,80	0,4	0,5	10	6	60	0,9	0,76	1,6	10,37	10,70	11,06	12,81	A	MBN102-008-0040-1000A060-HP820	31153358
0,80	0,4	1	4	6	60	0,9	0,76	1,6	4,21	4,44	4,59	5,04	A	MBN102-008-0040-0400B060-HP820	31153359
0,80	0,4	1	6	6	60	0,9	0,76	1,6	5,09	6,44	6,65	7,48	A	MBN102-008-0040-0600B060-HP820	31153360
0,80	0,4	1	8	6	60	0,9	0,76	1,6	5,09	8,44	8,70	9,92	A	MBN102-008-0040-0800B060-HP820	31153361
0,80	0,4	1	10	6	60	0,9	0,76	1,6	5,09	10,44	10,75	12,35	A	MBN102-008-0040-1000B060-HP820	31153362
1,00	0,5	0,5	10	6	60	1,2	0,94	2	10,43	10,73	11,12	12,86	A	MBN102-010-0050-1000A060-HP820	31153365
1,00	0,5	0,5	15	6	60	1,2	0,94	2	15,43	15,87	16,59	19,23	A	MBN102-010-0050-1500A060-HP820	31153366
1,00	0,5	0,5	20	6	75	1,2	0,94	2	20,43	21,09	22,06	25,59	A	MBN102-010-0050-2000A060-HP820	31153374
1,00	0,5	0,5	25	6	75	1,2	0,94	2	25,43	26,32	27,53	31,96	A	MBN102-010-0050-2500A060-HP820	31153379
1,00	0,5	0,5	30	6	75	1,2	0,94	2	30,43	31,54	33,00	38,32	A	MBN102-010-0050-3000A075-HP820	31153384
1,00	0,5	0,5	35	6	100	1,2	0,94	2	35,43	36,76	38,46	44,68	A	MBN102-010-0050-3500A075-HP820	31153389
1,00	0,5	1	5	6	60	1,2	0,94	2	5,28	5,51	5,66	6,34	A	MBN102-010-0050-0500B060-HP820	31153364
1,00	0,5	1	10	6	60	1,2	0,94	2	6,94	10,51	10,78	12,43	A	MBN102-010-0050-1000B060-HP820	31153367
1,00	0,5	1	15	6	60	1,2	0,94	2	6,94	15,51	15,98	18,52	A	MBN102-010-0050-1500B060-HP820	31153368
1,00	0,5	1	20	6	75	1,2	0,94	2	6,94	20,51	21,22	24,61	A	MBN102-010-0050-2000B060-HP820	31153369
1,00	0,5	1	25	6	75	1,2	0,94	2	6,94	25,51	26,45	30,70	A	MBN102-010-0050-2500B060-HP820	31153370
1,00	0,5	1	30	6	75	1,2	0,94	2	6,94	30,51	31,68	36,79	A	MBN102-010-0050-3000B075-HP820	31153371
1,00	0,5	1	35	6	100	1,2	0,94	2	6,94	35,51	36,92	42,88	A	MBN102-010-0050-3500B075-HP820	31153372
1,00	0,5	1,5	5	6	60	1,2	0,94	2	4,47	5,38	5,58	6,17	A	MBN102-010-0050-0500C060-HP820	31153373
1,00	0,5	1,5	10	6	60	1,2	0,94	2	4,47	8,44	10,58	11,99	A	MBN102-010-0050-1000C060-HP820	31153375
1,00	0,5	1,5	15	6	60	1,2	0,94	2	4,47	8,44	15,58	17,81	A	MBN102-010-0050-1500C060-HP820	31153376
1,00	0,5	1,5	20	6	75	1,2	0,94	2	4,47	8,44	20,58	23,63	A	MBN102-010-0050-2000C060-HP820	31153377
1,00	0,5	1,5	25	6	75	1,2	0,94	2	4,47	8,44	25,58	29,45	A	MBN102-010-0050-2500C060-HP820	31153378
1,00	0,5	1,5	30	6	75	1,2	0,94	2	4,47	8,44	30,58	35,27	A	MBN102-010-0050-3000C075-HP820	31153380
1,00	0,5	1,5	35	6	75	1,2	0,94	2	4,47	8,44	35,58	41,09	A	MBN102-010-0050-3500C075-HP820	31153381
2,00	1	0,5	15	6	60	2,3	1,94	4	15,87	16,56	17,03	19,18	A	MBN102-020-0100-1500A060-HP801	31153396
2,00	1	0,5	20	6	60	2,3	1,94	4	20,87	21,72	22,27	25,54	A	MBN102-020-0100-2000A060-HP801	31153397
2,00	1	0,5	25	6	75	2,3	1,94	4	25,87	26,87	27,55	31,91	A	MBN102-020-0100-2500A060-HP801	31153405
2,00	1	0,5	30	6	75	2,3	1,94	4	30,87	32,00	33,02	38,27	A	MBN102-020-0100-3000A075-HP801	31153410
2,00	1	0,5	35	6	75	2,3	1,94	4	35,87	37,13	38,49	43,28	A	MBN102-020-0100-3500A075-HP801	31153415
2,00	1	1	10	6	60	2,3	1,94	4	10,27	11,10	11,54	12,49	A	MBN102-020-0100-1000B060-HP801	31153395
2,00	1	1	15	6	60	2,3	1,94	4	10,44	16,10	16,71	18,58	A	MBN102-020-0100-1500B060-HP801	31153398
2,00	1	1	20	6	60	2,3	1,94	4	10,44	21,10	21,87	24,67	A	MBN102-020-0100-2000B060-HP801	31153399

OptiMill®-3D-BN | MBN102 | Ball nose milling cutter, conical design, z=2

Dimensions									Working depth at x° incline				Type	Specification	Order no.
d ₁	R	φ [°]	l ₃	d ₂ h5	l ₁	l ₂	d ₃	l ₅	0.5°	1°	1.5°	3°			
2,00	1	1	25	6	75	2,3	1,94	4	10,44	26,10	27,00	30,76	A	MBN102-020-0100-2500B060-HP801	31153400
2,00	1	1	30	6	75	2,3	1,94	4	10,44	31,10	32,13	36,85	A	MBN102-020-0100-3000B075-HP801	31153401
2,00	1	1	35	6	75	2,3	1,94	4	10,44	36,10	37,25	42,00	A	MBN102-020-0100-3500B075-HP801	31153402
2,00	1	1,5	10	6	60	2,3	1,94	4	7,22	10,71	11,30	12,32	A	MBN102-020-0100-1000C060-HP801	31153403
2,00	1	1,5	15	6	60	2,3	1,94	4	7,22	13,45	16,30	17,98	A	MBN102-020-0100-1500C060-HP801	31153404
2,00	1	1,5	20	6	60	2,3	1,94	4	7,22	13,45	21,30	23,80	A	MBN102-020-0100-2000C060-HP801	31153406
2,00	1	1,5	25	6	75	2,3	1,94	4	7,22	13,45	26,30	29,62	A	MBN102-020-0100-2500C060-HP801	31153407
2,00	1	1,5	30	6	75	2,3	1,94	4	7,22	13,45	31,30	35,43	A	MBN102-020-0100-3000C075-HP801	31153408
2,00	1	1,5	35	6	75	2,3	1,94	4	7,22	13,45	36,30	40,73	A	MBN102-020-0100-3500C075-HP801	31153409
2,00	1	3,0	35	8	75	2,3	1,94	4	5,29	6,36	8,15	36,82	A	MBN102-020-0100-3500D075-HP801	31153414
3,00	1,5	0,5	15	6	60	3,5	2,94	6	15,96	16,59	17,04	19,13	A	MBN102-030-0150-1500A060-HP801	31153420
3,00	1,5	0,5	20	6	60	3,5	2,94	6	20,96	21,75	22,29	25,49	A	MBN102-030-0150-2000A060-HP801	31153421
3,00	1,5	0,5	25	6	75	3,5	2,94	6	25,96	26,90	27,58	31,42	A	MBN102-030-0150-2500A060-HP801	31153428
3,00	1,5	0,5	30	6	75	3,5	2,94	6	30,96	32,03	33,04	36,21	A	MBN102-030-0150-3000A075-HP801	31153433
3,00	1,5	0,5	35	6	75	3,5	2,94	6	35,96	37,15	38,51	41,01	A	MBN102-030-0150-3500A075-HP801	31153438
3,00	1,5	0,5	40	6	100	3,5	2,94	6	40,96	42,27	43,98	45,80	A	MBN102-030-0150-4000A075-HP801	31153443
3,00	1,5	1	15	6	60	3,5	2,94	6	13,94	16,24	16,79	18,64	A	MBN102-030-0150-1500B060-HP801	31153422
3,00	1,5	1	20	6	60	3,5	2,94	6	13,94	21,24	21,94	24,73	A	MBN102-030-0150-2000B060-HP801	31153423
3,00	1,5	1	25	6	75	3,5	2,94	6	13,94	26,24	27,07	30,64	A	MBN102-030-0150-2500B060-HP801	31153424
3,00	1,5	1	30	6	75	3,5	2,94	6	13,94	31,24	32,19	35,23	A	MBN102-030-0150-3000B075-HP801	31153425
3,00	1,5	1	35	6	75	3,5	2,94	6	13,94	36,24	37,31	39,82	A	MBN102-030-0150-3500B075-HP801	31153426
3,00	1,5	1	40	6	100	3,5	2,94	6	13,94	41,24	42,42	44,41	A	MBN102-030-0150-4000B075-HP801	31153427
3,00	1,5	1,5	15	6	60	3,5	2,94	6	9,97	15,71	16,49	18,15	A	MBN102-030-0150-1500C060-HP801	31153429
3,00	1,5	1,5	20	6	60	3,5	2,94	6	9,97	18,46	21,49	23,97	A	MBN102-030-0150-2000C060-HP801	31153430
3,00	1,5	1,5	25	6	75	3,5	2,94	6	9,97	18,46	26,49	29,78	A	MBN102-030-0150-2500C060-HP801	31153431
3,00	1,5	1,5	30	6	75	3,5	2,94	6	9,97	18,46	31,49	34,24	A	MBN102-030-0150-3000C075-HP801	31153432
3,00	1,5	1,5	35	6	75	3,5	2,94	6	9,97	18,46	36,49	37,94	B	MBN102-030-0150-3500C075-HP801	31153434
3,00	1,5	1,5	40	6	75	3,5	2,94	6	9,97	18,46	40,80	43,01	C	MBN102-030-0150-4000C075-HP801	31153435
4,00	2	0,5	20	6	60	4,6	3,94	8	21,04	21,78	22,30	24,35	A	MBN102-040-0200-2000A060-HP801	31153448
4,00	2	0,5	25	6	75	4,6	3,94	8	26,04	26,92	27,60	29,15	A	MBN102-040-0200-2500A060-HP801	31153449
4,00	2	0,5	30	6	75	4,6	3,94	8	30,40	31,68	33,07	33,94	A	MBN102-040-0200-3000A075-HP801	31153456
4,00	2	0,5	35	6	75	4,6	3,94	8	36,04	37,18	37,88	37,98	B	MBN102-040-0200-3500A075-HP801	31153461
4,00	2	0,5	40	6	75	4,6	3,94	8	41,04	42,29	42,91	-	B	MBN102-040-0200-4000A075-HP801	31153466
4,00	2	0,5	45	6	100	4,6	3,94	8	46,04	47,40	47,83	-	B	MBN102-040-0200-4500A100-HP801	31153471
4,00	2	0,5	50	6	100	4,6	3,94	8	50,40	52,57	53,12	-	C	MBN102-040-0200-5000A100-HP801	31153476
4,00	2	1	20	6	60	4,6	3,94	8	17,44	21,37	22,01	23,86	A	MBN102-040-0200-2000B060-HP801	31153450
4,00	2	1	25	6	60	4,6	3,94	8	17,44	26,37	27,13	27,87	B	MBN102-040-0200-2500B060-HP801	31153451
4,00	2	1	30	6	75	4,6	3,94	8	17,44	30,69	32,04	33,04	C	MBN102-040-0200-3000B075-HP801	31153452
4,00	2	1	35	6	75	4,6	3,94	8	17,44	35,69	37,27	37,63	C	MBN102-040-0200-3500B075-HP801	31153453
4,00	2	1	40	6	75	4,6	3,94	8	17,44	40,69	42,22	-	C	MBN102-040-0200-4000B075-HP801	31153454
4,00	2	1	45	8	100	4,6	3,94	8	17,44	46,37	47,74	51,51	A	MBN102-040-0200-4500B100-HP801	31153455
4,00	2	1	50	8	100	4,6	3,94	8	17,44	51,37	52,98	56,10	A	MBN102-040-0200-5000B100-HP801	31153457
4,00	2	1,5	20	6	60	4,6	3,94	8	12,72	20,71	21,65	22,84	B	MBN102-040-0200-2000C060-HP801	31153458
4,00	2	1,5	25	6	60	4,6	3,94	8	12,72	23,47	26,01	27,75	C	MBN102-040-0200-2500C060-HP801	31153459
4,00	2	1,5	30	8	75	4,6	3,94	8	12,72	23,47	31,65	35,77	A	MBN102-040-0200-3000C064-HP801	31153460
4,00	2	1,5	35	8	75	4,6	3,94	8	12,72	23,47	36,65	41,22	A	MBN102-040-0200-3500C075-HP801	31153462
4,00	2	1,5	40	8	100	4,6	3,94	8	12,72	23,47	41,65	45,61	A	MBN102-040-0200-4000C075-HP801	31153463
4,00	2	1,5	45	8	100	4,6	3,94	8	12,72	23,47	46,65	49,99	A	MBN102-040-0200-4500C100-HP801	31153464
4,00	2	1,5	50	8	100	4,6	3,94	8	12,72	23,47	51,65	54,38	A	MBN102-040-0200-5000C100-HP801	31153465
4,00	2	3,0	50	10	100	4,6	3,94	8	9,89	11,86	15,16	52,33	B	MBN102-040-0200-5000D100-HP801	31153473
5,00	2,5	1	30	8	75	5,8	4,9	10	23,24	31,57	32,36	35,65	A	MBN102-050-0250-3000B064-HP801	31153481
5,00	2,5	1	50	8	100	5,8	4,9	10	23,24	51,57	52,75	53,08	B	MBN102-050-0250-5000B100-HP801	31153482
5,00	2,5	1,5	30	8	75	5,8	4,9	10	16,62	30,41	31,86	34,83	A	MBN102-050-0250-3000C064-HP801	31153483
6,00	3	1	35	8	75	6,9	5,9	12	26,74	36,06	37,62	38,05	C	MBN102-060-0300-3500B075-HP801	31153487
6,00	3	1	40	8	75	6,9	5,9	12	26,74	41,06	42,64	-	C	MBN102-060-0300-4000B075-HP801	31153488
6,00	3	1	50	10	100	6,9	5,9	12	26,74	51,67	53,32	56,52	A	MBN102-060-0300-5000B100-HP801	31153489
6,00	3	1	60	10	110	6,9	5,9	12	26,74	61,67	63,79	65,70	A	MBN102-060-0300-6000B100-HP801	31153496

Continued on next page.

OptiMill®-3D-BN | MBN102 | Ball nose milling cutter, conical design, z=2

Dimensions									Working depth at x° incline				Type	Specification	Order no.
d ₁	R	φ [°]	l ₃	d ₂ h5	l ₁	l ₂	d ₃	l ₅	0.5°	1°	1.5°	3°			
6,00	3	1,5	35	10	100	6,9	5,9	12	19,37	35,41	36,99	41,81	A	MBN102-060-0300-3500C075-HP801	31153490
6,00	3	1,5	40	10	100	6,9	5,9	12	19,37	35,77	41,99	46,20	A	MBN102-060-0300-4000C075-HP801	31153491
8,00	4	1	50	12	100	9,2	7,8	16	39,47	51,59	53,82	57,09	A	MBN102-080-0400-5000B100-HP801	31153499
8,00	4	1	70	12	120	9,2	7,8	16	39,47	72,01	74,76	75,45	A	MBN102-080-0400-7000B120-HP801	31153502
8,00	4	1	90	12	140	9,2	7,8	16	39,47	91,59	93,80	-	C	MBN102-080-0400-9000B135-HP801	31153500
8,00	4	3	50	12	100	9,2	7,8	16	20,69	24,87	31,85	51,50	C	MBN102-080-0400-5000D100-HP801	31153501
10,00	5	1	50	16	110	11,5	9,8	16	38,48	51,95	53,68	61,69	A	MBN102-100-0500-5000B100-HP801	31153506
10,00	5	1	70	16	130	11,5	9,8	16	38,48	71,95	74,62	80,15	A	MBN102-100-0500-7000B120-HP801	31153507
10,00	5	1	90	16	150	11,5	9,8	16	38,48	91,95	95,56	98,51	A	MBN102-100-0500-9000B140-HP801	31153508
12,00	6	1	50	16	105	13,8	11,8	16	37,48	51,90	53,55	57,09	A	MBN102-120-0600-5000B100-HP801	31153511
12,00	6	1	70	16	125	13,8	11,8	16	37,48	71,90	73,19	73,54	B	MBN102-120-0600-7000B120-HP801	31153512
12,00	6	1	90	16	145	13,8	11,8	16	37,48	91,41	93,80	-	C	MBN102-120-0600-9000B140-HP801	31153513

Available on request

1,00	0,5	3	15	6	60	1,2	0,94	2	2,99	3,61	4,65	15,76	A	MBN102-010-0050-1500D060-HP820	31153382
1,00	0,5	3	20	6	60	1,2	0,94	2	2,99	3,61	4,65	20,76	A	MBN102-010-0050-2000D060-HP820	31153383
1,00	0,5	3	25	6	75	1,2	0,94	2	2,99	3,61	4,65	25,76	A	MBN102-010-0050-2500D060-HP820	31153385
1,00	0,5	3	30	6	75	1,2	0,94	2	2,99	3,61	4,65	30,76	A	MBN102-010-0050-3000D075-HP820	31153386
1,00	0,5	3	35	6	75	1,2	0,94	2	2,99	3,61	4,65	35,76	A	MBN102-010-0050-3500D075-HP820	31153387
2,00	1	3	20	6	60	2,3	1,94	4	5,29	6,36	8,15	21,82	A	MBN102-020-0100-2000D060-HP801	31153411
2,00	1	3	25	6	75	2,3	1,94	4	5,29	6,36	8,15	26,82	A	MBN102-020-0100-2500D060-HP801	31153412
2,00	1	3	30	8	75	2,3	1,94	4	5,29	6,36	8,15	31,82	A	MBN102-020-0100-3000D064-HP801	31153413
3,00	1,5	3	20	6	60	3,5	2,94	6	7,59	9,11	11,66	22,10	B	MBN102-030-0150-2000D060-HP801	31153436
3,00	1,5	3	25	6	60	3,5	2,94	6	7,59	9,11	11,66	26,67	C	MBN102-030-0150-2500D060-HP801	31153437
3,00	1,5	3	30	8	75	3,5	2,94	6	7,59	9,11	11,66	32,10	A	MBN102-030-0150-3000D064-HP801	31153439
3,00	1,5	3	35	8	75	3,5	2,94	6	7,59	9,11	11,66	37,10	A	MBN102-030-0150-3500D075-HP801	31153440
3,00	1,5	3	40	8	75	3,5	2,94	6	7,59	9,11	11,66	42,10	B	MBN102-030-0150-4000D075-HP801	31153441
4,00	2	3	25	8	64	4,6	3,94	8	9,89	11,86	15,16	27,33	A	MBN102-040-0200-2500D064-HP801	31153467
4,00	2	3	30	8	75	4,6	3,94	8	9,89	11,86	15,16	32,33	B	MBN102-040-0200-3000D064-HP801	31153468
4,00	2	3	35	8	75	4,6	3,94	8	9,89	11,86	15,16	37,17	C	MBN102-040-0200-3500D075-HP801	31153469
4,00	2	3	40	8	75	4,6	3,94	8	9,89	11,86	15,16	41,66	C	MBN102-040-0200-4000D075-HP801	31153470
4,00	2	3	45	10	100	4,6	3,94	8	9,89	11,86	15,16	47,33	A	MBN102-040-0200-4500D100-HP801	31153472
5,00	2,5	3	30	10	75	5,8	4,9	10	12,65	15,19	19,43	32,79	A	MBN102-050-0250-3000D075-HP801	31153484
5,00	2,5	3	50	12	100	5,8	4,9	10	12,65	15,19	19,43	52,79	A	MBN102-050-0250-5000D100-HP801	31153485
6,00	3	3	35	10	75	6,9	5,9	12	14,95	17,94	22,93	37,76	B	MBN102-060-0300-3500D075-HP801	31153492
6,00	3	3	40	10	100	6,9	5,9	12	14,95	17,94	22,93	42,74	C	MBN102-060-0300-4000D075-HP801	31153493
6,00	3	3	50	12	100	6,9	5,9	12	14,95	17,94	22,93	52,76	B	MBN102-060-0300-5000D100-HP801	31153494
6,00	3	3	60	12	120	6,9	5,9	12	14,95	17,94	22,93	62,51	C	MBN102-060-0300-6000D100-HP801	31153495
8,00	4	3	70	16	125	9,2	7,8	16	20,69	24,87	31,85	73,16	B	MBN102-080-0400-7000D120-HP801	31153503
8,00	4	3	90	16	140	9,2	7,8	16	20,69	24,87	31,85	91,04	C	MBN102-080-0400-9000D140-HP801	31153504
10,00	5	3	50	16	105	11,5	9,8	16	20,49	24,38	30,86	53,07	B	MBN102-100-0500-5000D100-HP801	31153509
10,00	5	3	70	16	120	11,5	9,8	16	20,49	24,38	30,86	71,27	C	MBN102-100-0500-7000D120-HP801	31153510
12,00	6	3	50	16	100	13,8	11,8	16	20,29	23,88	29,88	51,50	C	MBN102-120-0600-5000D100-HP801	31153514

Dimensions in mm.

For cutting data recommendations, see end of chapter.

Special designs and other coatings available upon request.

OptiMill®-3D-BN

Ball nose milling cutter, z=4
MBN103

Design:

Diameter of milling cutter: 6.00 - 12.00 mm
Cutting material: HP801
Number of cutting edges: 4
Helix angle: 30°
Radial contour tolerance: ±0.005 if $d_1 \leq 6$ mm
±0.01 if $d_1 > 6$ mm

Application:

Suitable for machining workpiece materials up to 55 HRC.

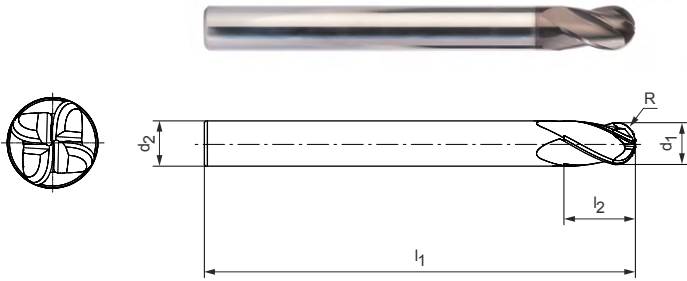

Preferred series in stock

Dimensions					z	Specification	Order no.
d ₁	R	d ₂ h5	l ₁	l ₂			
6,00	3	6	60	6,9	4	MBN103-060-0300-X060-HP801	31153515
6,00	3	6	100	6,9	4	MBN103-060-0300-X100-HP801	31153516
8,00	4	8	64	9,2	4	MBN103-080-0400-X064-HP801	31153517
8,00	4	8	100	9,2	4	MBN103-080-0400-X100-HP801	31153518
10,00	5	10	75	11,5	4	MBN103-100-0500-X075-HP801	31153519
10,00	5	10	120	11,5	4	MBN103-100-0500-X120-HP801	31153520
12,00	6	12	75	13,8	4	MBN103-120-0600-X075-HP801	31153521
12,00	6	12	120	13,8	4	MBN103-120-0600-X120-HP801	31153522

Dimensions in mm.
For cutting data recommendations, see end of chapter.
Special designs and other coatings available upon request.

Application note

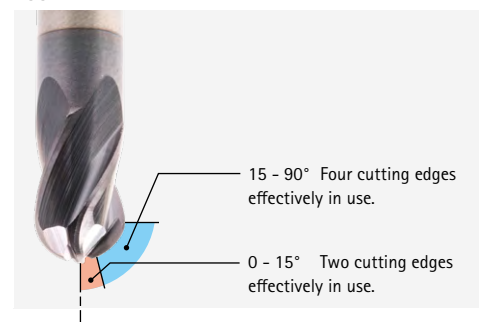

OptiMill®-3D-BN

Ball nose milling cutter, design with neck, z=4
MBN104

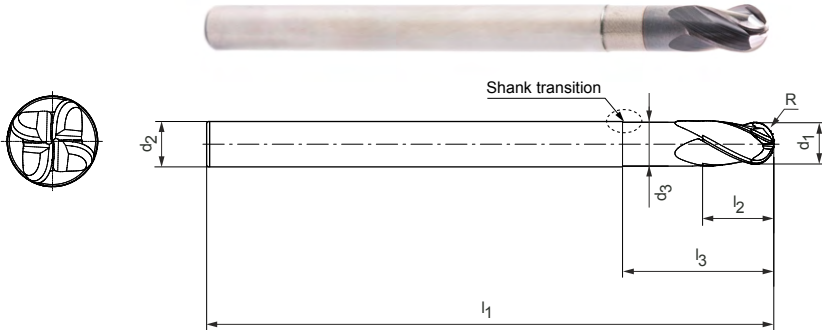

Design:

- Diameter of milling cutter: 3.00 - 12.00 mm
- Cutting material: HP801
- Number of cutting edges: 4
- Helix angle: 30°
- Radial contour tolerance: ±0.005 if $d_1 \leq 6$ mm
±0.01 if $d_1 > 6$ mm

Application:

Suitable for machining workpiece materials up to 55 HRC.

Shank transition:

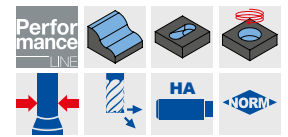
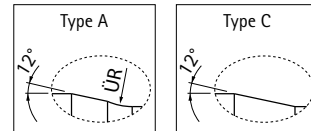

Preferred series in stock

Dimensions						Working depth at x° incline				Type	Specification	Order no.	
d ₁	R	l ₃	d ₂ h5	l ₁	l ₂	d ₃	0.5°	1°	1.5°				3°
3,00	1,5	10	6	60	3,5	2,94	11,17	11,56	11,88	12,98	A	MBN104-030-0150-1000X060-HP801	31153525
3,00	1,5	15	6	60	3,5	2,94	16,38	16,87	17,26	19,62	A	MBN104-030-0150-1500X060-HP801	31153526
3,00	1,5	20	6	60	3,5	2,94	21,56	22,13	22,76	26,25	A	MBN104-030-0150-2000X060-HP801	31153527
3,00	1,5	25	6	75	3,5	2,94	26,71	27,36	28,47	32,20	A	MBN104-030-0150-2500X075-HP801	31153528
4,00	2	10	6	60	4,6	3,94	11,14	11,52	11,84	12,82	A	MBN104-040-0200-1000X060-HP801	31153529
4,00	2	15	6	60	4,6	3,94	16,36	16,84	17,23	19,46	A	MBN104-040-0200-1500X060-HP801	31153530
4,00	2	20	6	60	4,6	3,94	21,54	22,10	22,69	24,85	A	MBN104-040-0200-2000X060-HP801	31153531
4,00	2	25	6	75	4,6	3,94	26,70	27,33	28,40	29,85	A	MBN104-040-0200-2500X075-HP801	31153532
4,00	2	30	6	75	4,6	3,94	31,84	32,66	34,10	34,85	A	MBN104-040-0200-3000X075-HP801	31153533
5,00	2,5	20	6	60	5,8	4,9	21,00	21,82	22,59	-	C	MBN104-050-0250-2000X060-HP801	31153535
5,00	2,5	30	6	75	5,8	4,9	31,42	32,59	-	-	C	MBN104-050-0250-3000X075-HP801	31153537
6,00	3	15	6	60	6,9	5,9	-	-	-	-	-	MBN104-060-0300-1500X060-HP801	31153538
6,00	3	20	6	60	6,9	5,9	-	-	-	-	-	MBN104-060-0300-2000X060-HP801	31153539
6,00	3	25	6	60	6,9	5,9	-	-	-	-	-	MBN104-060-0300-2500X060-HP801	31153540
6,00	3	30	6	75	6,9	5,9	-	-	-	-	-	MBN104-060-0300-3000X075-HP801	31153541
6,00	3	35	6	75	6,9	5,9	-	-	-	-	-	MBN104-060-0300-3500X075-HP801	31153542
8,00	4	25	8	64	9,2	7,8	-	-	-	-	-	MBN104-080-0400-2500X064-HP801	31153543
8,00	4	50	8	100	9,2	7,8	-	-	-	-	-	MBN104-080-0400-5000X100-HP801	31153544
10,00	5	30	10	75	11,5	9,8	-	-	-	-	-	MBN104-100-0500-3000X075-HP801	31153545
10,00	5	50	10	100	11,5	9,8	-	-	-	-	-	MBN104-100-0500-5000X100-HP801	31153546
12,00	6	35	12	75	13,8	11,8	-	-	-	-	-	MBN104-120-0600-3500X075-HP801	31153547
12,00	6	60	12	100	13,8	11,8	-	-	-	-	-	MBN104-120-0600-6000X100-HP801	31153548

Available on request

5,00	2,5	15	6	60	5,8	4,9	15,78	16,38	17,03	17,59	C	MBN104-050-0250-1500X060-HP801	31153534
5,00	2,5	25	6	60	5,8	4,9	26,21	27,27	27,59	-	C	MBN104-050-0250-2500X060-HP801	31153536

Dimensions in mm.

For cutting data recommendations, see end of chapter.

Special designs and other coatings available upon request.

Application note

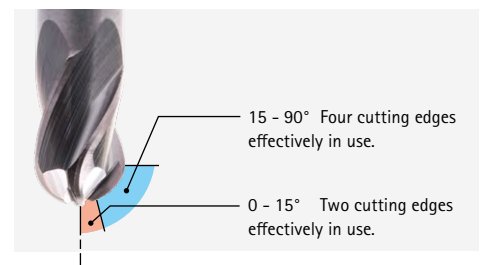

OptiMill®-3D-BN

Ball nose milling cutter, conical design, z=4
MBN105

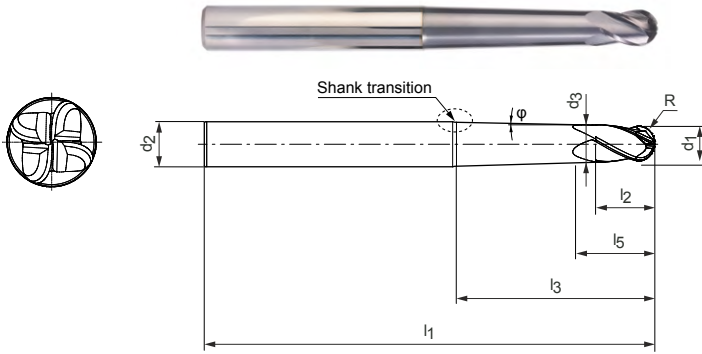

Design:

Diameter of milling cutter: 3.00 - 12.00 mm
Cutting material: HP801
Number of cutting edges: 4
Helix angle: 30°
Radial contour tolerance: ±0.005 if d₁ ≤ 6 mm
±0.01 if d₁ > 6 mm

Application:

Suitable for machining workpiece materials up to 55 HRC.

Shank transition:

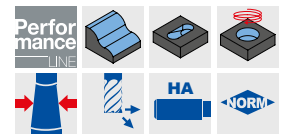
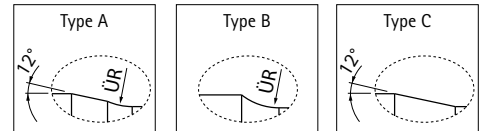

Preferred series in stock

Dimensions									Working depth at x° incline				Type	Specification	Order no.
d ₁	R	φ [°]	l ₃	d ₂ h5	l ₁	l ₂	d ₃	l ₅	0.5°	1°	1.5°	3°			
3,00	1,5	0,5	15	6	60	3,5	2,94	6	15,96	16,59	17,04	19,13	A	MBN105-030-0150-1500A060-HP801	31153551
3,00	1,5	0,5	20	6	60	3,5	2,94	6	20,96	21,75	22,29	25,49	A	MBN105-030-0150-2000A060-HP801	31153554
3,00	1,5	0,5	25	6	75	3,5	2,94	6	25,96	26,90	27,58	31,42	A	MBN105-030-0150-2500A075-HP801	31153559
3,00	1,5	0,5	30	6	75	3,5	2,94	6	30,96	32,03	33,04	36,21	A	MBN105-030-0150-3000A075-HP801	31153564
3,00	1,5	1	15	6	60	3,5	2,94	6	13,94	16,24	16,79	18,64	A	MBN105-030-0150-1500B060-HP801	31153552
3,00	1,5	1	20	6	60	3,5	2,94	6	13,94	21,24	21,94	24,73	A	MBN105-030-0150-2000B060-HP801	31153555
3,00	1,5	1	25	6	75	3,5	2,94	6	13,94	26,24	27,07	30,64	A	MBN105-030-0150-2500B075-HP801	31153560
3,00	1,5	1	30	6	75	3,5	2,94	6	13,94	31,24	32,19	35,23	A	MBN105-030-0150-3000B075-HP801	31153565
3,00	1,5	1	35	6	75	3,5	2,94	6	13,94	36,24	37,31	39,82	A	MBN105-030-0150-3500B075-HP801	31153569
3,00	1,5	1	40	6	100	3,5	2,94	6	13,94	41,24	42,42	44,41	A	MBN105-030-0150-4000B100-HP801	31153573
3,00	1,5	1,5	15	6	60	3,5	2,94	6	9,97	15,71	16,49	18,15	A	MBN105-030-0150-1500C060-HP801	31153553
3,00	1,5	1,5	20	6	60	3,5	2,94	6	9,97	18,46	21,49	23,97	A	MBN105-030-0150-2000C060-HP801	31153556
3,00	1,5	1,5	25	6	75	3,5	2,94	6	9,97	18,46	26,49	29,78	A	MBN105-030-0150-2500C075-HP801	31153561
3,00	1,5	1,5	30	6	75	3,5	2,94	6	9,97	18,46	31,49	34,24	A	MBN105-030-0150-3000C075-HP801	31153566
3,00	1,5	1,5	35	6	75	3,5	2,94	6	9,97	18,46	36,49	37,94	B	MBN105-030-0150-3500C075-HP801	31153570
3,00	1,5	1,5	40	6	75	3,5	2,94	6	9,97	18,46	40,80	43,01	C	MBN105-030-0150-4000C075-HP801	31153574
4,00	2	0,5	20	6	60	4,6	3,94	8	21,04	21,78	22,30	24,35	A	MBN105-040-0200-2000A060-HP801	31153577
4,00	2	0,5	25	6	75	4,6	3,94	8	26,04	26,92	27,60	29,15	A	MBN105-040-0200-2500A075-HP801	31153580
4,00	2	0,5	30	6	75	4,6	3,94	8	31,04	32,06	33,07	33,94	A	MBN105-040-0200-3000A075-HP801	31153585
4,00	2	0,5	35	6	75	4,6	3,94	8	36,04	37,18	37,88	37,98	B	MBN105-040-0200-3500A075-HP801	31153590
4,00	2	0,5	40	6	75	4,6	3,94	8	41,04	42,29	42,91	-	B	MBN105-040-0200-4000A075-HP801	31153595
4,00	2	0,5	45	6	100	4,6	3,94	8	46,04	47,40	47,83	-	B	MBN105-040-0200-4500A100-HP801	31153600
4,00	2	1	20	6	60	4,6	3,94	8	17,44	21,37	22,01	23,86	A	MBN105-040-0200-2000B060-HP801	31153578
4,00	2	1	25	6	60	4,6	3,94	8	17,44	26,37	27,13	27,87	B	MBN105-040-0200-2500B060-HP801	31153581
4,00	2	1	30	6	75	4,6	3,94	8	17,44	30,69	32,04	33,04	C	MBN105-040-0200-3000B075-HP801	31153586
4,00	2	1	35	6	75	4,6	3,94	8	17,44	35,69	37,27	37,63	C	MBN105-040-0200-3500B075-HP801	31153591
4,00	2	1	40	8	100	4,6	3,94	8	17,44	41,37	42,51	46,92	A	MBN105-040-0200-4000B100-HP801	31153596
4,00	2	1	45	8	100	4,6	3,94	8	17,44	46,37	47,74	51,51	A	MBN105-040-0200-4500B100-HP801	31153601
4,00	2	1	50	8	100	4,6	3,94	8	17,44	51,37	52,98	56,10	A	MBN105-040-0200-5000B100-HP801	31153605
4,00	2	1,5	20	6	60	4,6	3,94	8	12,72	20,71	21,65	22,84	B	MBN105-040-0200-2000C060-HP801	31153579
4,00	2	1,5	25	6	60	4,6	3,94	8	12,72	23,47	26,01	27,75	C	MBN105-040-0200-2500C060-HP801	31153582
4,00	2	1,5	30	8	75	4,6	3,94	8	12,72	23,47	31,65	35,77	A	MBN105-040-0200-3000C075-HP801	31153587
4,00	2	1,5	35	8	75	4,6	3,94	8	12,72	23,47	36,65	41,22	A	MBN105-040-0200-3500C075-HP801	31153592
4,00	2	1,5	40	8	100	4,6	3,94	8	12,72	23,47	41,65	45,61	A	MBN105-040-0200-4000C100-HP801	31153597
4,00	2	1,5	45	8	100	4,6	3,94	8	12,72	23,47	46,65	49,99	A	MBN105-040-0200-4500C100-HP801	31153602

OptiMill®-3D-BN | MBN105 | Ball nose milling cutter, conical design, z=4

Dimensions									Working depth at x° incline				Type	Specification	Order no.
d ₁	R	φ [°]	l ₃	d ₂ h5	l ₁	l ₂	d ₃	l ₅	0.5°	1°	1.5°	3°			
5,00	2,5	1	30	8	75	5,8	4,9	10	23,24	31,57	32,36	35,65	A	MBN105-050-0250-3000B075-HP801	31153608
5,00	2,5	1	50	8	100	5,8	4,9	10	23,24	51,57	52,75	53,08	B	MBN105-050-0250-5000B100-HP801	31153611
5,00	2,5	1,5	30	8	75	5,8	4,9	10	16,62	30,41	31,86	34,83	A	MBN105-050-0250-3000C075-HP801	31153609
6,00	3	1	35	8	75	6,9	5,9	12	26,74	36,06	37,62	38,05	C	MBN105-060-0300-3500B075-HP801	31153614
6,00	3	1	40	8	75	6,9	5,9	12	26,74	41,06	42,64	-	C	MBN105-060-0300-4000B075-HP801	31153617
6,00	3	1	50	10	100	6,9	5,9	12	26,74	51,67	53,32	56,52	A	MBN105-060-0300-5000B100-HP801	31153620
6,00	3	1	60	10	110	6,9	5,9	12	26,74	61,67	63,79	65,70	A	MBN105-060-0300-6000B110-HP801	31153623
6,00	3	1,5	35	10	100	6,9	5,9	12	19,37	35,41	36,99	41,81	A	MBN105-060-0300-3500C100-HP801	31153615
6,00	3	1,5	40	10	100	6,9	5,9	12	19,37	35,77	41,99	46,20	A	MBN105-060-0300-4000C100-HP801	31153618
8,00	4	1	50	12	100	9,2	7,8	16	39,47	52,01	53,82	57,09	A	MBN105-120-0400-5000B100-HP801	31153626
8,00	4	1	70	12	120	9,2	7,8	16	39,47	72,01	74,76	75,45	A	MBN105-120-0400-7000B120-HP801	31153629
8,00	4	1	90	12	140	9,2	7,8	16	39,47	91,59	93,80	-	C	MBN105-120-0400-9000B140-HP801	31153631
10,00	5	1	50	12	100	11,5	9,8	16	38,48	51,50	52,38	-	C	MBN105-120-0500-5000B100-HP801	31153633
10,00	5	1	70	12	120	11,5	9,8	16	38,48	70,74	-	-	C	MBN105-120-0500-7000B120-HP801	31153635
10,00	5	1	90	16	150	11,5	9,8	16	38,48	91,95	95,56	98,51	A	MBN105-160-0500-9000B150-HP801	31153637
12,00	6	0,5	50	16	110	13,8	11,8	16	51,54	52,93	55,14	58,48	A	MBN105-160-0600-5000A110-HP801	31153638
12,00	6	0,5	70	16	130	13,8	11,8	16	71,54	73,83	77,01	77,66	A	MBN105-160-0600-7000A130-HP801	31153640
12,00	6	0,5	90	16	145	13,8	11,8	16	91,54	94,72	96,84	-	A	MBN105-160-0600-9000A145-HP801	31153642
12,00	6	1,5	50	16	105	13,8	11,8	16	26,74	47,55	52,21	53,61	B	MBN105-160-0600-5000C105-HP801	31153639
12,00	6	1,5	70	16	125	13,8	11,8	16	26,74	47,55	71,95	73,23	C	MBN105-160-0600-7000C125-HP801	31153641
12,00	6	1,5	90	16	140	13,8	11,8	16	26,74	47,55	90,76	-	C	MBN105-160-0600-9000C140-HP801	31153643

Available on request

3,00	1,5	3	20	6	60	3,5	2,94	6	7,59	9,11	11,66	22,10	B	MBN105-030-0150-2000D060-HP801	31153557
3,00	1,5	3	25	8	64	3,5	2,94	6	7,59	9,11	11,66	27,10	A	MBN105-030-0150-2500D064-HP801	31153562
3,00	1,5	3	30	8	75	3,5	2,94	6	7,59	9,11	11,66	32,10	A	MBN105-030-0150-3000D075-HP801	31153567
3,00	1,5	3	35	8	75	3,5	2,94	6	7,59	9,11	11,66	37,10	A	MBN105-030-0150-3500D075-HP801	31153571
3,00	1,5	3	40	8	75	3,5	2,94	6	7,59	9,11	11,66	42,10	B	MBN105-030-0150-4000D075-HP801	31153575
4,00	2	3	25	8	64	4,6	3,94	8	9,89	11,86	15,16	27,33	A	MBN105-040-0200-2500D064-HP801	31153583
4,00	2	3	30	8	75	4,6	3,94	8	9,89	11,86	15,16	32,33	B	MBN105-040-0200-3000D075-HP801	31153588
4,00	2	3	35	8	75	4,6	3,94	8	9,89	11,86	15,16	37,17	C	MBN105-040-0200-3500D075-HP801	31153593
4,00	2	3	40	10	100	4,6	3,94	8	9,89	11,86	15,16	42,33	A	MBN105-040-0200-4000D100-HP801	31153598
4,00	2	3	45	10	100	4,6	3,94	8	9,89	11,86	15,16	47,33	A	MBN105-040-0200-4500D100-HP801	31153603
4,00	2	3	50	10	100	4,6	3,94	8	9,89	11,86	15,16	52,33	B	MBN105-040-0200-5000D100-HP801	31153606
5,00	2,5	3	30	10	75	5,8	4,9	10	12,65	15,19	19,43	32,79	A	MBN105-050-0250-3000D075-HP801	31153610
5,00	2,5	3	50	12	100	5,8	4,9	10	12,65	15,19	19,43	52,79	A	MBN105-050-0250-5000D100-HP801	31153612
6,00	3	3	35	10	75	6,9	5,9	12	14,95	17,94	22,93	37,76	B	MBN105-060-0300-3500D075-HP801	31153616
6,00	3	3	40	10	100	6,9	5,9	12	14,95	17,94	22,93	42,74	C	MBN105-060-0300-4000D100-HP801	31153619
6,00	3	3	50	12	100	6,9	5,9	12	14,95	17,94	22,93	52,76	B	MBN105-060-0300-5000D100-HP801	31153621
6,00	3	3	60	12	120	6,9	5,9	12	14,95	17,94	22,93	62,51	C	MBN105-060-0300-6000D120-HP801	31153624
8,00	4	3	50	12	100	9,2	7,8	16	20,69	24,87	31,85	51,50	C	MBN105-120-0400-5000D100-HP801	31153627
8,00	4	3	70	16	125	9,2	7,8	16	20,69	24,87	31,85	73,16	B	MBN105-160-0400-7000D125-HP801	31153630
8,00	4	3	90	16	140	9,2	7,8	16	20,69	24,87	31,85	91,04	C	MBN105-160-0400-9000D140-HP801	31153632
10,00	5	3	50	16	105	11,5	9,8	16	20,49	24,38	30,86	53,07	B	MBN105-160-0500-5000D105-HP801	31153634
10,00	5	3	70	16	120	11,5	9,8	16	20,49	24,38	30,86	71,27	C	MBN105-160-0500-7000D120-HP801	31153636

Dimensions in mm.
 For cutting data recommendations, see end of chapter.
 Special designs and other coatings available upon request.

Application note

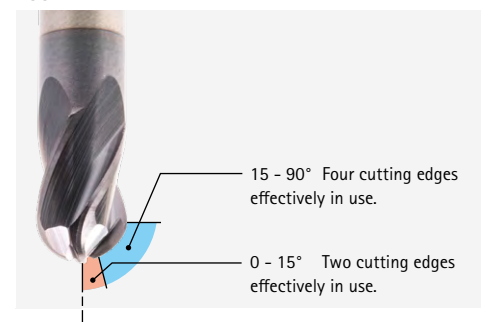

OptiMill®-3D-BN-Hardened

Ball nose milling cutter, z=2
MBN106

Design:

Diameter of milling cutter: 6.00 - 12.00 mm
Cutting material: HP808
Number of cutting edges: 2
Helix angle: 30°
Radial contour tolerance: ±0.005 if $d_1 \leq 6$ mm
±0.01 if $d_1 > 6$ mm

Application:

Suitable for machining workpiece materials up to 68 HRC.

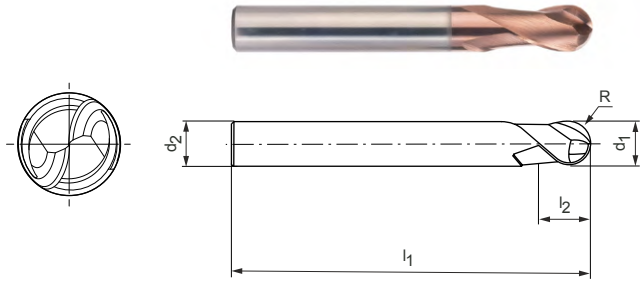

Preferred series in stock

Dimensions					z	Specification	Order no.
d ₁	R	d ₂ h5	l ₁	l ₂			
6,00	3	6	60	6,9	2	MBN106-060-0300-X060-HP808	31153644
6,00	3	6	100	6,9	2	MBN106-060-0300-X100-HP808	31153645
8,00	4	8	64	9,2	2	MBN106-080-0400-X064-HP808	31153646
8,00	4	8	75	9,2	2	MBN106-080-0400-X075-HP808	31354867
8,00	4	8	100	9,2	2	MBN106-080-0400-X100-HP808	31153647
10,00	5	10	75	11,5	2	MBN106-100-0500-X075-HP808	31153648
10,00	5	10	120	11,5	2	MBN106-100-0500-X120-HP808	31153649
12,00	6	12	75	13,8	2	MBN106-120-0600-X075-HP808	31153650
12,00	6	12	120	13,8	2	MBN106-120-0600-X120-HP808	31153651

Dimensions in mm.

For cutting data recommendations, see end of chapter.

Special designs and other coatings available upon request.

OptiMill®-3D-BN-Hardened

Ball nose milling cutter, design with neck, z=2
MBN107

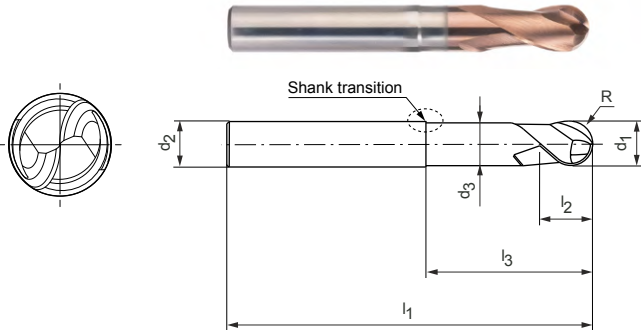

Design:

Diameter of milling cutter: 0.10 - 12.00 mm
Cutting material: HP808/HP818
Number of cutting edges: 2
Helix angle: 30°
Radial contour tolerance: ±0.005 if d₁ ≤ 6 mm
±0.01 if d₁ > 6 mm

Application:

Suitable for machining workpiece materials up to 68 HRC.

Shank transition:

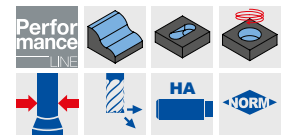
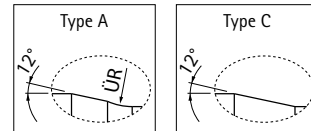

Preferred series in stock

Dimensions						Working depth at x° incline				Type	Specification	Order no.	
d ₁	R	l ₃	d ₂ h5	l ₁	l ₂	d ₃	0.5°	1°	1.5°				3°
0,50	0,25	1,5	4	50	0,6	0,46	1,87	1,94	2,01	2,19	A	MBN107-005-0025-0150X050-HP818	31153680
0,50	0,25	2	4	50	0,6	0,46	2,39	2,48	2,56	2,77	A	MBN107-005-0025-0200X050-HP818	31153681
0,50	0,25	3	4	50	0,6	0,46	3,43	3,55	3,65	4,03	A	MBN107-005-0025-0300X050-HP818	31153682
0,50	0,25	4	4	50	0,6	0,46	4,47	4,61	4,73	5,35	A	MBN107-005-0025-0400X050-HP818	31153683
0,50	0,25	4	6	60	0,6	0,46	4,47	4,61	4,73	5,35	A	MBN107-005-0025-0400X060-HP818	31153686
0,60	0,3	2	4	50	0,7	0,56	2,39	2,48	2,56	2,76	A	MBN107-006-0030-0200X050-HP818	31153688
0,60	0,3	3	4	50	0,7	0,56	3,43	3,55	3,65	4,01	A	MBN107-006-0030-0300X050-HP818	31153689
0,60	0,3	4	4	50	0,7	0,56	4,47	4,61	4,72	5,34	A	MBN107-006-0030-0400X050-HP818	31153690
0,60	0,3	4	6	60	0,7	0,56	4,47	4,61	4,72	5,34	A	MBN107-006-0030-0400X060-HP818	31153691
0,60	0,3	5	4	50	0,7	0,56	5,51	5,66	5,79	6,67	A	MBN107-006-0030-0500X050-HP818	31153693
0,80	0,4	3	4	50	0,9	0,76	3,43	3,54	3,64	3,98	A	MBN107-008-0040-0300X050-HP818	31153696
0,80	0,4	4	4	50	0,9	0,76	4,47	4,60	4,72	5,31	A	MBN107-008-0040-0400X050-HP818	31153697
0,80	0,4	6	4	50	0,9	0,76	6,54	6,71	6,89	7,96	A	MBN107-008-0040-0600X050-HP818	31153698
0,80	0,4	6	6	60	0,9	0,76	6,54	6,71	6,89	7,96	A	MBN107-008-0040-0600X060-HP818	31153700
1,00	0,5	3	4	50	1,2	0,94	3,47	3,57	3,66	4,01	A	MBN107-010-0050-0300X050-HP818	31153703
1,00	0,5	4	4	50	1,2	0,94	4,51	4,63	4,74	5,34	A	MBN107-010-0050-0400X050-HP818	31153704
1,00	0,5	5	4	50	1,2	0,94	5,54	5,68	5,80	6,66	A	MBN107-010-0050-0500X050-HP818	31153705
1,00	0,5	6	4	50	1,2	0,94	6,57	6,73	6,93	7,99	A	MBN107-010-0050-0600X050-HP818	31153706
1,00	0,5	8	4	50	1,2	0,94	8,63	8,83	9,22	10,65	A	MBN107-010-0050-0800X050-HP818	31153707
1,00	0,5	10	4	50	1,2	0,94	10,68	11,00	11,50	13,30	A	MBN107-010-0050-1000X050-HP818	31153708
1,00	0,5	10	6	60	1,2	0,94	10,68	11,00	11,50	13,30	A	MBN107-010-0050-1000X060-HP818	31153709
1,50	0,75	5	4	50	1,7	1,44	5,53	5,67	5,79	6,58	A	MBN107-015-0075-0500X050-HP818	31153712
1,50	0,75	6	4	50	1,7	1,44	6,56	6,72	6,90	7,91	A	MBN107-015-0075-0600X050-HP818	31153713
1,50	0,75	8	4	50	1,7	1,44	8,62	8,81	9,18	10,57	A	MBN107-015-0075-0800X050-HP818	31153714
1,50	0,75	10	4	50	1,7	1,44	10,67	10,98	11,46	13,22	A	MBN107-015-0075-1000X050-HP818	31153715
1,50	0,75	10	6	60	1,7	1,44	10,67	10,98	11,46	13,22	A	MBN107-015-0075-1000X060-HP818	31153716
1,50	0,75	12	4	50	1,7	1,44	12,72	13,16	13,74	15,88	A	MBN107-015-0075-1200X050-HP818	31153717
1,50	0,75	12	6	60	1,7	1,44	12,72	13,16	13,74	15,88	A	MBN107-015-0075-1200X060-HP818	31153718
1,50	0,75	15	4	50	1,7	1,44	15,79	16,43	17,16	19,86	A	MBN107-015-0075-1500X050-HP818	31153719
1,50	0,75	15	6	60	1,7	1,44	15,79	16,43	17,16	19,86	A	MBN107-015-0075-1500X060-HP818	31153720
1,80	0,9	6	4	50	2,1	1,74	6,56	6,71	6,88	7,86	A	MBN107-018-0090-0600X050-HP818	31153721
1,80	0,9	8	4	50	2,1	1,74	8,62	8,80	9,16	10,52	A	MBN107-018-0090-0800X050-HP818	31153722
1,80	0,9	10	4	50	2,1	1,74	10,67	10,97	11,44	13,17	A	MBN107-018-0090-1000X050-HP818	31153723
1,80	0,9	15	4	50	2,1	1,74	15,78	16,42	17,14	19,81	A	MBN107-018-0090-1500X050-HP818	31153724
2,00	1	6	4	50	2,3	1,94	6,99	7,29	7,54	8,17	A	MBN107-020-0100-0600X050-HP808	31153726

OptiMill®-3D-BN-Hardened | MBN107 | Ball nose milling cutter, design with neck, z=2

Dimensions							Working depth at x° incline				Type	Specification	Order no.
d ₁	R	l ₃	d ₂ h5	l ₁	l ₂	d ₃	0.5°	1°	1.5°	3°			
2,00	1	8	4	50	2,3	1,94	9,09	9,45	9,74	10,49	A	MBN107-020-0100-0800X050-HP808	31153727
2,00	1	10	4	50	2,3	1,94	11,19	11,59	11,92	13,14	A	MBN107-020-0100-1000X050-HP808	31153728
2,00	1	12	4	50	2,3	1,94	13,28	13,72	14,08	15,80	A	MBN107-020-0100-1200X050-HP808	31153729
2,00	1	15	4	50	2,3	1,94	16,39	16,90	17,30	19,78	A	MBN107-020-0100-1500X050-HP808	31153730
2,00	1	15	6	60	2,3	1,94	16,39	16,90	17,30	19,78	A	MBN107-020-0100-1500X060-HP808	31153731
2,00	1	18	4	50	2,3	1,94	19,50	20,05	20,55	22,85	A	MBN107-020-0100-1800X050-HP808	31153732
2,00	1	20	4	50	2,3	1,94	21,57	22,15	22,83	24,85	A	MBN107-020-0100-2000X050-HP808	31153733
2,00	1	20	6	75	2,3	1,94	21,57	22,15	22,83	26,41	A	MBN107-020-0100-2000X075-HP808	31153734
2,50	1,25	8	4	50	2,9	2,44	9,08	9,43	9,72	10,43	A	MBN107-025-0125-0800X050-HP808	31153736
2,50	1,25	10	4	50	2,9	2,44	11,18	11,58	11,90	13,06	A	MBN107-025-0125-1000X050-HP808	31153737
2,50	1,25	15	4	50	2,9	2,44	16,39	16,88	17,28	18,67	A	MBN107-025-0125-1500X050-HP808	31153738
2,50	1,25	15	6	60	2,9	2,44	16,39	16,88	17,28	19,70	A	MBN107-025-0125-1500X060-HP808	31153739
2,50	1,25	20	4	50	2,9	2,44	21,56	22,14	22,80	23,67	A	MBN107-025-0125-2000X050-HP808	31153740
2,50	1,25	20	6	60	2,9	2,44	21,56	22,14	22,80	26,33	A	MBN107-025-0125-2000X060-HP808	31153741
2,50	1,25	25	6	75	2,9	2,44	26,72	27,37	28,50	32,97	A	MBN107-025-0125-2500X075-HP808	31153743
3,00	1,5	10	6	60	3,5	2,94	11,17	11,56	11,88	12,98	A	MBN107-030-0150-1000X060-HP808	31153744
3,00	1,5	15	6	60	3,5	2,94	16,38	16,87	17,26	19,62	A	MBN107-030-0150-1500X060-HP808	31153745
3,00	1,5	20	6	60	3,5	2,94	21,56	22,13	22,76	26,25	A	MBN107-030-0150-2000X060-HP808	31153746
3,00	1,5	25	6	75	3,5	2,94	26,71	27,36	28,47	32,20	A	MBN107-030-0150-2500X075-HP808	31153748
4,00	2	10	6	60	4,6	3,94	11,14	11,52	11,84	12,82	A	MBN107-040-0200-1000X060-HP808	31153749
4,00	2	15	6	60	4,6	3,94	16,36	16,84	17,23	19,46	A	MBN107-040-0200-1500X060-HP808	31153750
4,00	2	20	6	60	4,6	3,94	21,54	22,10	22,69	24,85	A	MBN107-040-0200-2000X060-HP808	31153751
4,00	2	25	6	75	4,6	3,94	26,70	27,33	28,40	29,85	A	MBN107-040-0200-2500X075-HP808	31153752
4,00	2	30	6	75	4,6	3,94	31,84	32,66	34,10	34,85	A	MBN107-040-0200-3000X075-HP808	31153753
4,00	2	35	6	75	4,6	3,94	36,98	38,11	39,80	39,85	A	MBN107-040-0200-3500X075-HP808	31153754
5,00	2,5	15	6	60	5,8	4,9	15,78	16,38	17,03	17,59	C	MBN107-050-0250-1500X060-HP808	31153755
5,00	2,5	20	6	60	5,8	4,9	21,00	21,82	22,59	-	C	MBN107-050-0250-2000X060-HP808	31153756
5,00	2,5	25	6	60	5,8	4,9	26,21	27,27	27,59	-	C	MBN107-050-0250-2500X060-HP808	31153757
5,00	2,5	30	6	75	5,8	4,9	31,42	32,59	-	-	C	MBN107-050-0250-3000X075-HP808	31153758
6,00	3	15	6	60	6,9	5,9	-	-	-	-	-	MBN107-060-0300-1500X060-HP808	31153759
6,00	3	20	6	60	6,9	5,9	-	-	-	-	-	MBN107-060-0300-2000X060-HP808	31153760
6,00	3	25	6	60	6,9	5,9	-	-	-	-	-	MBN107-060-0300-2500X060-HP808	31153761
6,00	3	30	6	75	6,9	5,9	-	-	-	-	-	MBN107-060-0300-3000X075-HP808	31153762
6,00	3	35	6	75	6,9	5,9	-	-	-	-	-	MBN107-060-0300-3500X075-HP808	31153763
8,00	4	25	8	64	9,2	7,8	-	-	-	-	-	MBN107-080-0400-2500X064-HP808	31153764
8,00	4	50	8	100	9,2	7,8	-	-	-	-	-	MBN107-080-0400-5000X100-HP808	31153765
10,00	5	30	10	75	11,5	9,8	-	-	-	-	-	MBN107-100-0500-3000X075-HP808	31153766
10,00	5	50	10	100	11,5	9,8	-	-	-	-	-	MBN107-100-0500-5000X100-HP808	31153767
12,00	6	35	12	75	13,8	11,8	-	-	-	-	-	MBN107-120-0600-3500X075-HP808	31153768
12,00	6	60	12	100	13,8	11,8	-	-	-	-	-	MBN107-120-0600-6000X100-HP808	31153769

Available on request

0,10	0,05	0,3	4	50	0,1	0,07	0,56	0,60	0,63	0,74	A	MBN107-001-0005-0030X050-HP818	31153654
0,10	0,05	0,3	6	60	0,1	0,07	0,56	0,60	0,63	0,74	A	MBN107-001-0005-0030X060-HP818	31153655
0,10	0,05	0,4	4	50	0,1	0,07	0,67	0,71	0,75	0,87	A	MBN107-001-0005-0040X050-HP818	31153656
0,10	0,05	0,4	6	60	0,1	0,07	0,67	0,71	0,75	0,87	A	MBN107-001-0005-0040X060-HP818	31153657
0,20	0,1	0,5	4	50	0,2	0,17	0,79	0,83	0,87	0,99	A	MBN107-002-0010-0050X050-HP818	31153658
0,20	0,1	0,5	6	60	0,2	0,17	0,79	0,83	0,87	0,99	A	MBN107-002-0010-0050X060-HP818	31153659
0,20	0,1	0,75	4	50	0,2	0,17	1,05	1,11	1,16	1,30	A	MBN107-002-0010-0075X050-HP818	31153660
0,20	0,1	1	4	50	0,2	0,17	1,32	1,39	1,45	1,61	A	MBN107-002-0010-0100X050-HP818	31153661
0,20	0,1	1	6	60	0,2	0,17	1,32	1,39	1,45	1,61	A	MBN107-002-0010-0100X060-HP818	31153662
0,20	0,1	1,25	4	50	0,2	0,17	1,58	1,66	1,73	1,90	A	MBN107-002-0010-0125X050-HP818	31153663
0,20	0,1	1,5	4	50	0,2	0,17	1,85	1,93	2,01	2,20	A	MBN107-002-0010-0150X050-HP818	31153664
0,20	0,1	1,5	6	60	0,2	0,17	1,85	1,93	2,01	2,20	A	MBN107-002-0010-0150X060-HP818	31153665
0,30	0,15	0,5	4	50	0,3	0,27	0,79	0,83	0,87	0,98	A	MBN107-003-0015-0050X050-HP818	31153666
0,30	0,15	0,75	4	50	0,3	0,27	1,05	1,10	1,15	1,29	A	MBN107-003-0015-0075X050-HP818	31153667

Continued on next page.

OptiMill®-3D-BN-Hardened | MBN107 | Ball nose milling cutter, design with neck, z=2

Dimensions							Working depth at x° incline				Type	Specification	Order no.
d ₁	R	l ₃	d ₂ h5	l ₁	l ₂	d ₃	0.5°	1°	1.5°	3°			
0,30	0,15	1	4	50	0,3	0,27	1,32	1,38	1,44	1,60	A	MBN107-003-0015-0100X050-HP818	31153668
0,30	0,15	1	6	60	0,3	0,27	1,32	1,38	1,44	1,60	A	MBN107-003-0015-0100X060-HP818	31153669
0,30	0,15	1,25	4	50	0,3	0,27	1,58	1,65	1,72	1,89	A	MBN107-003-0015-0125X050-HP818	31153670
0,30	0,15	1,5	4	50	0,3	0,27	1,84	1,93	2,00	2,19	A	MBN107-003-0015-0150X050-HP818	31153671
0,30	0,15	1,5	6	60	0,3	0,27	1,84	1,93	2,00	2,19	A	MBN107-003-0015-0150X060-HP818	31153672
0,30	0,15	2	6	60	0,3	0,27	2,37	2,47	2,55	2,77	A	MBN107-003-0015-0200X060-HP818	31153673
0,40	0,2	0,75	4	50	0,5	0,37	1,05	1,10	1,15	1,28	A	MBN107-004-0020-0075X050-HP818	31153674
0,40	0,2	1	4	50	0,5	0,37	1,31	1,38	1,43	1,59	A	MBN107-004-0020-0100X050-HP818	31153675
0,40	0,2	1,5	4	50	0,5	0,37	1,84	1,92	1,99	2,18	A	MBN107-004-0020-0150X050-HP818	31153676
0,40	0,2	2	4	50	0,5	0,37	2,37	2,46	2,55	2,76	A	MBN107-004-0020-0200X050-HP818	31153677
0,40	0,2	2	6	60	0,5	0,37	2,37	2,46	2,55	2,76	A	MBN107-004-0020-0200X060-HP818	31153678
0,40	0,2	3	6	60	0,5	0,37	3,41	3,54	3,64	4,01	A	MBN107-004-0020-0300X060-HP818	31153679

Dimensions in mm.

For cutting data recommendations, see end of chapter.

Special designs and other coatings available upon request.

OptiMill®-3D-BN-Hardened

Ball nose milling cutter, z=4
MBN108

Design:

Diameter of milling cutter: 6.00 - 12.00 mm
Cutting material: HP808
Number of cutting edges: 4
Helix angle: 35°
Radial contour tolerance: ±0.005 if $d_1 \leq 6$ mm
±0.01 if $d_1 > 6$ mm

Application:

Suitable for machining workpiece materials up to 68 HRC.

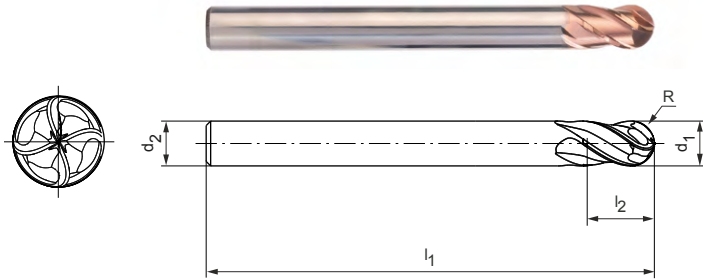

Preferred series in stock

Dimensions					z	Specification	Order no.
d ₁	R	d ₂ h5	l ₁	l ₂			
6,00	3	6	60	6,9	4	MBN108-060-0300-X060-HP808	31153772
6,00	3	6	100	6,9	4	MBN108-060-0300-X100-HP808	31153773
8,00	4	8	64	9,2	4	MBN108-080-0400-X064-HP808	31153774
8,00	4	8	100	9,2	4	MBN108-080-0400-X100-HP808	31153775
10,00	5	10	75	11,5	4	MBN108-100-0500-X075-HP808	31153776
10,00	5	10	120	11,5	4	MBN108-100-0500-X120-HP808	31153777
12,00	6	12	75	13,8	4	MBN108-120-0600-X075-HP808	31153778
12,00	6	12	120	13,8	4	MBN108-120-0600-X120-HP808	31153779

Dimensions in mm.

For cutting data recommendations, see end of chapter.

Special designs and other coatings available upon request.

OptiMill®-3D-BN-Hardened

Ball nose milling cutter, design with neck, z=4
MBN109

Design:

Diameter of milling cutter: 3.00 - 12.00 mm
Cutting material: HP808
Number of cutting edges: 4
Helix angle: 35°
Radial contour tolerance: ±0.005 if d₁ ≤ 6 mm
±0.01 if d₁ > 6 mm

Application:

Suitable for machining workpiece materials up to 68 HRC.

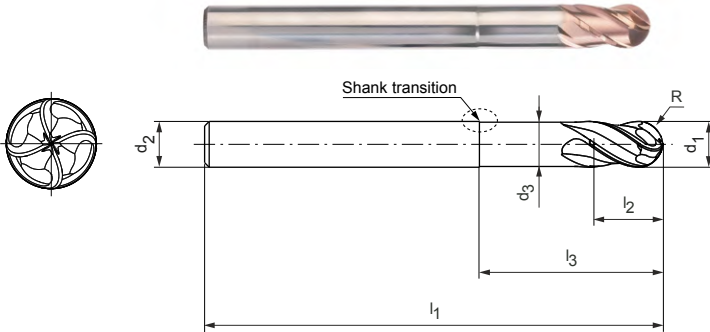

Shank transition:

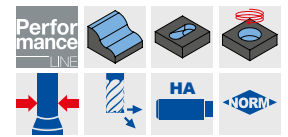
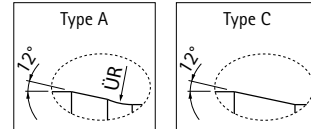

Preferred series in stock

Dimensions							Working depth at x° incline				Type	Specification	Order no.
d ₁	R	l ₃	d ₂ h5	l ₁	l ₂	d ₃	0.5°	1°	1.5°	3°			
3,00	1,5	10	6	60	3,5	2,94	11,17	11,56	11,88	12,98	A	MBN109-030-0150-1000X060-HP808	31153782
3,00	1,5	15	6	60	3,5	2,94	16,38	16,87	17,26	19,62	A	MBN109-030-0150-1500X060-HP808	31153783
3,00	1,5	20	6	60	3,5	2,94	21,56	22,13	22,76	26,25	A	MBN109-030-0150-2000X060-HP808	31153784
3,00	1,5	25	6	75	3,5	2,94	26,71	27,36	28,47	32,20	A	MBN109-030-0150-2500X075-HP808	31153785
4,00	2	10	6	60	4,6	3,94	11,14	11,52	11,84	12,82	A	MBN109-040-0200-1000X060-HP808	31153786
4,00	2	15	6	60	4,6	3,94	16,36	16,84	17,23	19,46	A	MBN109-040-0200-1500X060-HP808	31153787
4,00	2	20	6	60	4,6	3,94	21,54	22,10	22,69	24,85	A	MBN109-040-0200-2000X060-HP808	31153788
4,00	2	25	6	75	4,6	3,94	26,70	27,33	28,40	29,85	A	MBN109-040-0200-2500X075-HP808	31153789
4,00	2	30	6	75	4,6	3,94	31,84	32,66	34,10	34,85	A	MBN109-040-0200-3000X075-HP808	31153790
5,00	2,5	20	6	60	5,8	4,9	21,00	21,82	22,59	-	C	MBN109-050-0250-2000X060-HP808	31153792
5,00	2,5	30	6	75	5,8	4,9	31,42	32,59	-	-	C	MBN109-050-0250-3000X075-HP808	31153794
6,00	3	15	6	60	6,9	5,9	-	-	-	-	-	MBN109-060-0300-1500X060-HP808	31153795
6,00	3	20	6	60	6,9	5,9	-	-	-	-	-	MBN109-060-0300-2000X060-HP808	31153796
6,00	3	25	6	60	6,9	5,9	-	-	-	-	-	MBN109-060-0300-2500X060-HP808	31153797
6,00	3	30	6	75	6,9	5,9	-	-	-	-	-	MBN109-060-0300-3000X075-HP808	31153798
6,00	3	35	6	75	6,9	5,9	-	-	-	-	-	MBN109-060-0300-3500X075-HP808	31153799
8,00	4	25	8	64	9,2	7,8	-	-	-	-	-	MBN109-080-0400-2500X064-HP808	31153800
8,00	4	50	8	100	9,2	7,8	-	-	-	-	-	MBN109-080-0400-5000X100-HP808	31153801
10,00	5	30	10	75	11,5	9,8	-	-	-	-	-	MBN109-100-0500-3000X075-HP808	31153802
10,00	5	50	10	100	11,5	9,8	-	-	-	-	-	MBN109-100-0500-5000X100-HP808	31153803
12,00	6	35	12	75	13,8	11,8	-	-	-	-	-	MBN109-120-0600-3500X075-HP808	31153804
12,00	6	60	12	100	13,8	11,8	-	-	-	-	-	MBN109-120-0600-6000X100-HP808	31153805

Available on request

5,00	2,5	15	6	60	5,8	4,9	15,78	16,38	17,03	17,59	C	MBN109-050-0250-1500X060-HP808	31153791
5,00	2,5	25	6	60	5,8	4,9	26,21	27,27	27,59	-	C	MBN109-050-0250-2500X060-HP808	31153793

Dimensions in mm.

For cutting data recommendations, see end of chapter.

Special designs and other coatings available upon request.

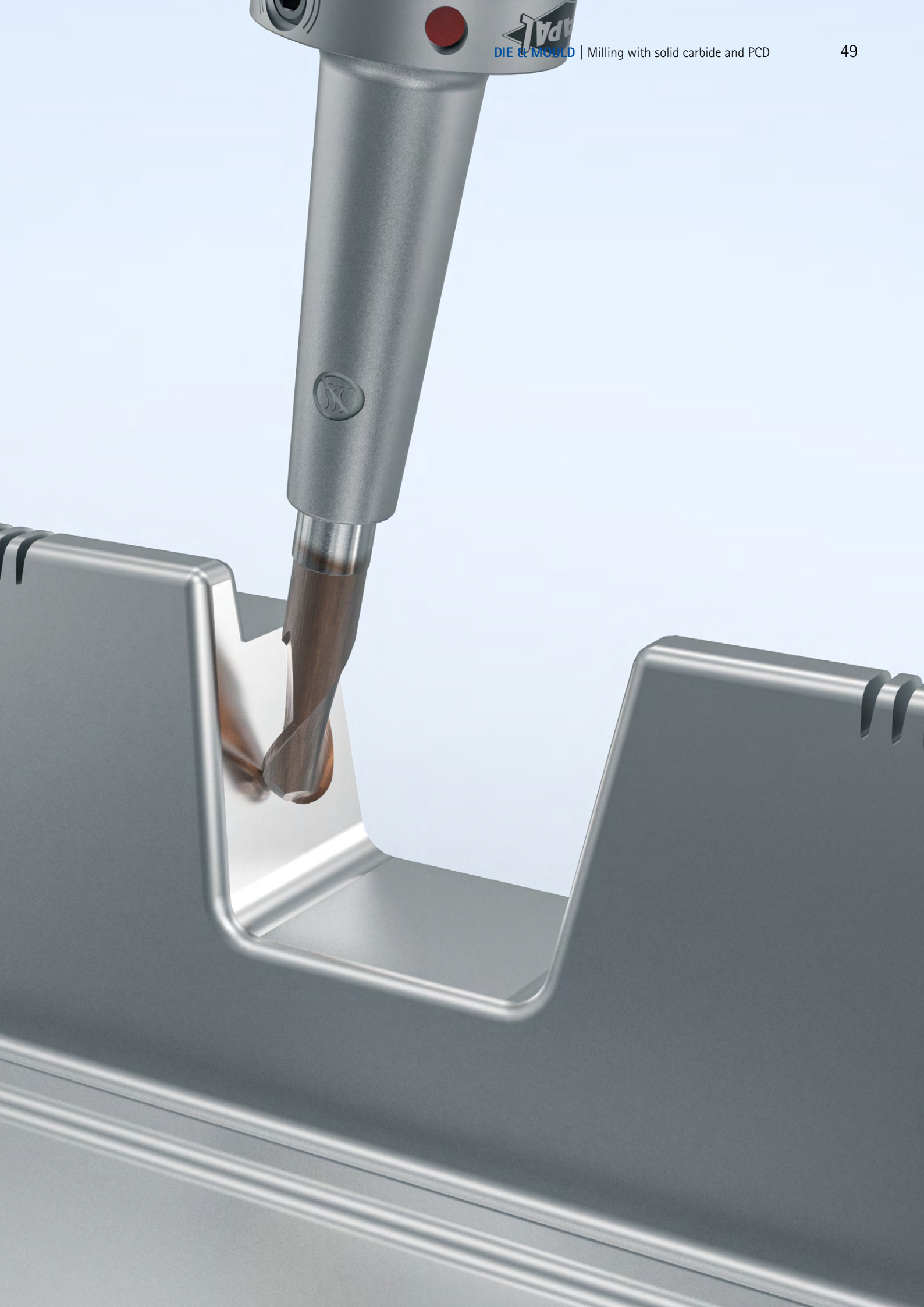

OptiMill®-3D-BN-Graphite

Ball nose milling cutter, design with neck, z=2
MBN110

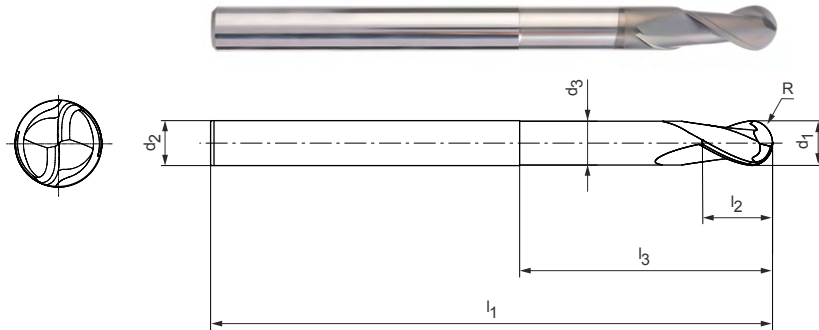

Design:

- Diameter of milling cutter: 0.20 - 10.00 mm
- Cutting material: HC115/HC116
- Number of cutting edges: 2
- Helix angle: 35°
- Radial contour tolerance: ±0.005 if $d_1 \leq 2$ mm
+0.01 / -0.015 if $d_1 > 2$ mm
- Special features: Diamond coating

Application:

Suitable for machining of graphite electrodes.
Mainly used for finishing and pre-finishing due to narrowed radius tolerance.

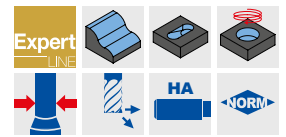

Preferred series in stock

Dimensions							z	Specification	Order no.
d ₁	R	l ₃	d ₂ h5	l ₁	l ₂	d ₃			
0,20	0,1	0,8	4	50	0,4	0,19	2	MBN110-002-0010-0080X050-HC115	31152804
0,20	0,1	2	4	50	0,4	0,19	2	MBN110-002-0010-0200X050-HC115	31152805
0,30	0,15	1,2	4	50	0,5	0,29	2	MBN110-003-0015-0120X050-HC115	31152806
0,30	0,15	2	4	50	0,5	0,29	2	MBN110-003-0015-0200X050-HC115	31152807
0,30	0,15	3	4	50	0,5	0,29	2	MBN110-003-0015-0300X050-HC115	31152808
0,40	0,2	1,2	4	50	0,6	0,37	2	MBN110-004-0020-0120X050-HC115	31152809
0,40	0,2	2,5	4	50	0,6	0,37	2	MBN110-004-0020-0250X050-HC115	31152810
0,40	0,2	5	4	50	0,6	0,37	2	MBN110-004-0020-0500X050-HC115	31152811
0,50	0,25	1,5	4	50	0,8	0,45	2	MBN110-005-0025-0150X050-HC115	31152812
0,50	0,25	3,5	4	50	0,8	0,45	2	MBN110-005-0025-0350X050-HC115	31152813
0,50	0,25	5	4	50	0,8	0,45	2	MBN110-005-0025-0500X050-HC115	31152814
0,50	0,25	7	4	50	0,8	0,45	2	MBN110-005-0025-0700X050-HC115	31152815
0,50	0,25	10	4	50	0,8	0,45	2	MBN110-005-0025-1000X050-HC115	31152816
0,60	0,3	1,2	4	50	0,9	0,55	2	MBN110-006-0030-0120X050-HC115	31152817
0,60	0,3	3,5	4	50	0,9	0,55	2	MBN110-006-0030-0350X050-HC115	31152818
0,60	0,3	5	4	50	0,9	0,55	2	MBN110-006-0030-0500X050-HC115	31152819
0,60	0,3	7	4	50	0,9	0,55	2	MBN110-006-0030-0700X050-HC115	31152820
0,60	0,3	10	4	50	0,9	0,55	2	MBN110-006-0030-1000X050-HC115	31152821
0,60	0,3	12	4	50	0,9	0,55	2	MBN110-006-0030-1200X050-HC115	31152822
0,80	0,4	5	4	50	1,2	0,75	2	MBN110-008-0040-0500X050-HC115	31152823
0,80	0,4	10	4	50	1,2	0,75	2	MBN110-008-0040-1000X050-HC115	31152824
0,80	0,4	12	4	50	1,2	0,75	2	MBN110-008-0040-1200X050-HC115	31152825
0,80	0,4	16	4	50	1,2	0,75	2	MBN110-008-0040-1600X050-HC115	31152826
1,00	0,5	5	4	50	1,5	0,95	2	MBN110-010-0050-0500X050-HC116	31152827
1,00	0,5	10	4	50	1,5	0,95	2	MBN110-010-0050-1000X050-HC116	31152828
1,00	0,5	15	4	50	1,5	0,95	2	MBN110-010-0050-1500X050-HC116	31152829
1,00	0,5	20	4	50	1,5	0,95	2	MBN110-010-0050-2000X050-HC116	31152830
1,50	0,75	10	4	50	2,3	1,4	2	MBN110-015-0075-1000X050-HC116	31152834
1,50	0,75	15	4	50	2,3	1,4	2	MBN110-015-0075-1500X050-HC116	31152835
1,50	0,75	20	4	50	2,3	1,4	2	MBN110-015-0075-2000X050-HC116	31152836
1,50	0,75	25	4	75	2,3	1,4	2	MBN110-015-0075-2500X075-HC116	31152838
2,00	1	10	4	50	4	1,9	2	MBN110-020-0100-1000X050-HC116	31152839
2,00	1	15	4	50	4	1,9	2	MBN110-020-0100-1500X050-HC116	31152840
2,00	1	20	4	75	4	1,9	2	MBN110-020-0100-2000X075-HC116	31152841
2,00	1	25	4	75	4	1,9	2	MBN110-020-0100-2500X075-HC116	31152842

OptiMill®-3D-BN-Graphite | MBN110 | Ball nose milling cutter, design with neck, z=2

Dimensions							z	Specification	Order no.
d ₁	R	l ₃	d ₂ h5	l ₁	l ₂	d ₃			
3,00	1,5	5	4	50	4,5	2,9	2	MBN110-030-0150-0500X050-HC116	31152843
3,00	1,5	10	4	50	6	2,9	2	MBN110-030-0150-1000X050-HC116	31152844
3,00	1,5	15	4	50	6	2,9	2	MBN110-030-0150-1500X050-HC116	31152845
3,00	1,5	20	4	75	6	2,9	2	MBN110-030-0150-2000X075-HC116	31152846
3,00	1,5	25	4	75	6	2,9	2	MBN110-030-0150-2500X075-HC116	31152847
3,00	1,5	30	4	75	6	2,9	2	MBN110-030-0150-3000X075-HC116	31152848
4,00	2	15	4	50	8	3,8	2	MBN110-040-0200-1500X050-HC116	31152849
4,00	2	20	4	75	8	3,8	2	MBN110-040-0200-2000X075-HC116	31152850
4,00	2	25	4	75	8	3,8	2	MBN110-040-0200-2500X075-HC116	31152851
4,00	2	45	4	100	8	3,8	2	MBN110-040-0200-4500X100-HC116	31152852
5,00	2,5	25	6	57	10	4,8	2	MBN110-050-0250-2500X057-HC116	31152853
5,00	2,5	45	6	100	10	4,8	2	MBN110-050-0250-4500X100-HC116	31152854
6,00	3	20	6	75	12	5,8	2	MBN110-060-0300-2000X075-HC116	31152855
6,00	3	25	6	75	12	5,8	2	MBN110-060-0300-2500X075-HC116	31152856
6,00	3	30	6	75	12	5,8	2	MBN110-060-0300-3000X075-HC116	31152857
6,00	3	45	6	100	12	5,8	2	MBN110-060-0300-4500X100-HC116	31152858
6,00	3	60	6	100	12	5,8	2	MBN110-060-0300-6000X100-HC116	31152859
8,00	4	25	8	63	16	7,8	2	MBN110-080-0400-2500X063-HC116	31152860
8,00	4	45	8	100	16	7,8	2	MBN110-080-0400-4500X100-HC116	31152861
8,00	4	60	8	150	16	7,8	2	MBN110-080-0400-6000X150-HC116	31152862
10,00	5	25	10	72	20	9,8	2	MBN110-100-0500-2500X072-HC116	31152863
10,00	5	45	10	100	20	9,8	2	MBN110-100-0500-4500X100-HC116	31152864
10,00	5	60	10	125	20	9,8	2	MBN110-100-0500-6000X125-HC116	31152865

Available on request

1,20	0,6	6	4	50	1,8	1,15	2	MBN110-012-0060-0600X050-HC116	31152831
1,20	0,6	12	4	50	1,8	1,15	2	MBN110-012-0060-1200X050-HC116	31152832
1,20	0,6	15	4	50	1,8	1,15	2	MBN110-012-0060-1500X050-HC116	31152833

Dimensions in mm.

For cutting data recommendations, see end of chapter.

Special designs and other coatings available upon request.

OptiMill®-3D-BN-Graphite

Ball nose milling cutter, design with neck, z=3
MBN111

Design:

Diameter of milling cutter: 3.00 - 12.00 mm
Cutting material: HC116
Number of cutting edges: 3
Helix angle: 28°
Radial contour tolerance: ±0.01
Special features: Diamond coating

Application:

Suitable for machining of graphite electrodes.
Mainly used for pre-finishing and roughing.

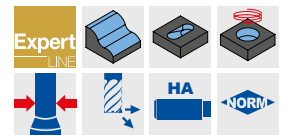
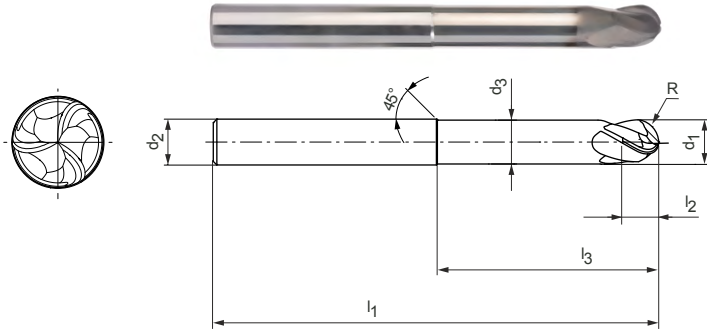

Preferred series in stock

Dimensions							z	Specification	Order no.
d ₁	R	l ₃	d ₂ h5	l ₁	l ₂	d ₃			
3,00	1,5	20	4	60	2	2,85	3	MBN111-030-0150-2000X060-HC116	31152866
3,00	1,5	30	4	60	2	2,85	3	MBN111-030-0150-3000X060-HC116	31152867
3,00	1,5	45	4	85	2	2,85	3	MBN111-030-0150-4500X085-HC116	31152868
4,00	2	20	4	60	3	3,8	3	MBN111-040-0200-2000X060-HC116	31152869
4,00	2	30	4	60	3	3,8	3	MBN111-040-0200-3000X060-HC116	31152870
4,00	2	40	4	75	3	3,8	3	MBN111-040-0200-4000X075-HC116	31152871
4,00	2	50	4	85	3	3,8	3	MBN111-040-0200-5000X085-HC116	31152872
5,00	2,5	30	6	60	4	4,8	3	MBN111-050-0250-3000X060-HC116	31152873
5,00	2,5	40	6	75	4	4,8	3	MBN111-050-0250-4000X075-HC116	31152874
6,00	3	30	6	60	4,5	5,7	3	MBN111-060-0300-3000X060-HC116	31152875
6,00	3	40	6	75	4,5	5,7	3	MBN111-060-0300-4000X075-HC116	31152876
6,00	3	60	6	100	4,5	5,7	3	MBN111-060-0300-6000X100-HC116	31152877
6,00	3	85	6	130	4,5	5,7	3	MBN111-060-0300-8500X130-HC116	31152878
8,00	4	45	8	75	6	7,7	3	MBN111-080-0400-4500X075-HC116	31152879
8,00	4	60	8	100	6	7,7	3	MBN111-080-0400-6000X100-HC116	31152880
8,00	4	85	8	130	6	7,7	3	MBN111-080-0400-8500X130-HC116	31152881
10,00	5	25	10	72	10	9,6	3	MBN111-100-0500-2500X072-HC116	31152882
10,00	5	50	10	100	10	9,6	3	MBN111-100-0500-5000X100-HC116	31152883
10,00	5	85	10	130	10	9,6	3	MBN111-100-0500-8500X130-HC116	31152884
12,00	6	60	12	100	12	11,6	3	MBN111-120-0600-6000X100-HC116	31152885
12,00	6	85	12	130	12	11,6	3	MBN111-120-0600-8500X130-HC116	31152886

Dimensions in mm.

For cutting data recommendations, see end of chapter.

Special designs and other coatings available upon request.

OptiMill®-3D-BN-Graphite-MT

Ball nose milling cutter, multi-tooth
MBN112

Design:

Diameter of milling cutter: 4.00 - 16.00 mm
Cutting material: HC117
Number of cutting edges: Multi-tooth / effective z=1
Special features: Diamond coating

Application:

Especially when it comes to roughing for high rates of removal for graphite electrodes.

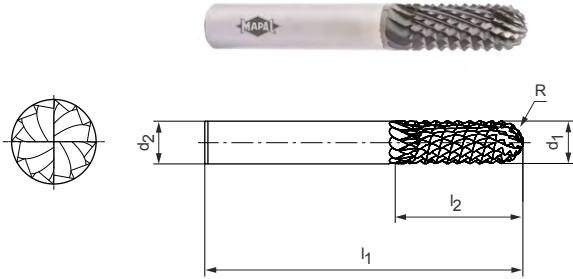

Preferred series in stock

Dimensions					z	Specification	Order no.
d ₁	R	d ₂ h5	l ₁	l ₂			
4,00	2	6	57	12	9	MBN112-040-0200-X057-HC117	31152887
5,00	2,5	6	57	15	10	MBN112-050-0250-X057-HC117	31152888
6,00	3	6	57	17	10	MBN112-060-0300-X057-HC117	31152889
8,00	4	8	63	20	12	MBN112-080-0400-X063-HC117	31152890
10,00	5	10	72	24	12	MBN112-100-0500-X072-HC117	31152891
12,00	6	12	83	30	16	MBN112-120-0600-X083-HC117	31152892
16,00	8	16	100	36	20	MBN112-160-0800-X100-HC117	31152893

Dimensions in mm.
For cutting data recommendations, see end of chapter.
Special designs and other coatings available upon request.

OptiMill®-Diamond-Radius

Ball nose milling cutter, overlong design with neck, includes internal cooling
SHM521

Design:

Diameter of milling cutter: 3.00 - 12.00 mm
Cutting material: PU611
Number of cutting edges: 2
Axis angle: 0°
Special features: PCD cutting edges for a long tool life

Application:

Ideal for contour and form milling aluminium parts.

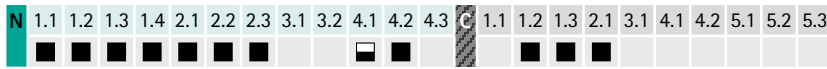
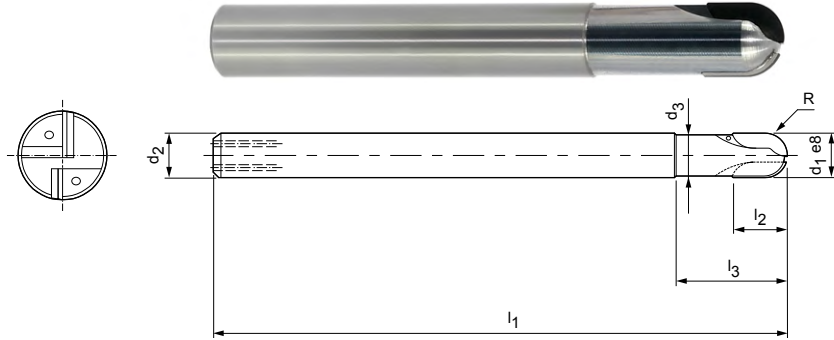

Preferred series in stock

Dimensions							z	Specification	Order no.
d ₁ h10	d ₂ h6	d ₃	l ₁	l ₂	l ₃	R			
3,00	6	2,8	60	2,5	9	1,5	2	SHM521-0300AZ02R-R0150HA-PU611	31348234
4,00	6	3,8	60	2,5	15	2	2	SHM521-0400AZ02R-R0200HA-PU611	31348235
5,00	6	4,6	60	3	15	2,5	2	SHM521-0500AZ02R-R0250HA-PU611	31348236
6,00	6	5,5	80	6	15	3	2	SHM521-0600BZ02R-R0300HA-PU611	31348237
8,00	8	7,4	80	10	20	4	2	SHM521-0800BZ02R-R0400HA-PU611	31348238
10,00	10	9,4	80	10	26	5	2	SHM521-1000BZ02R-R0500HA-PU611	31348239
12,00	12	11,2	100	10	35	6	2	SHM521-1200BZ02R-R0600HA-PU611	31348240

Dimensions in mm.
For cutting data recommendations, see end of chapter.
Special designs and CVD-tipped tools available upon request.

OptiMill®-3D-BN-Alu

Ball nose milling cutter, short design, z=2
MBN114

Design:

Diameter of milling cutter: 1.00 - 20.00 mm
Cutting material: HP807/HU644
Number of cutting edges: 2
Helix angle: 30°
Radial contour tolerance: ±0.01

Application:

Suitable for machining of high-strength aluminium alloys.

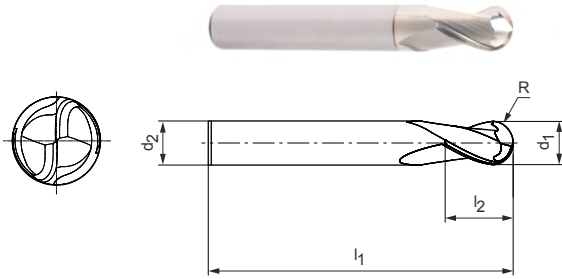

Preferred series in stock

Dimensions					z	Specification	Order no.
d ₁	R	d ₂ h5	l ₁	l ₂			
1,00	0,5	4	50	1,5	2	MBN114-010-0050-X050-HU644	31153118
1,50	0,75	4	50	2,5	2	MBN114-015-0075-X050-HU644	31153119
2,00	1	6	57	3	2	MBN114-020-0100-X057-HP807	31153120
2,00	1	4	50	3	2	MBN114-020-0100-X050-HP807	31153121
3,00	1,5	6	57	4,5	2	MBN114-030-0150-X057-HP807	31153122
4,00	2	6	57	6	2	MBN114-040-0200-X057-HP807	31153123
5,00	2,5	6	57	7,5	2	MBN114-050-0250-X057-HP807	31153124
6,00	3	6	57	9	2	MBN114-060-0300-X057-HP807	31153125
8,00	4	8	63	16	2	MBN114-080-0400-X063-HP807	31153126
10,00	5	10	72	15	2	MBN114-100-0500-X072-HP807	31153127
12,00	6	12	83	18	2	MBN114-120-0600-X083-HP807	31153128
16,00	8	16	92	24	2	MBN114-160-0800-X092-HP807	31153129
20,00	10	20	104	30	2	MBN114-200-1000-X104-HP807	31153130

Dimensions in mm.
For cutting data recommendations, see end of chapter.
Special designs and other coatings available upon request.

OptiMill®-3D-BN-Alu

Ball nose milling cutter, long design, z=2
MBN115

Design:

Diameter of milling cutter: 2.00 - 20.00 mm
Cutting material: HP807
Number of cutting edges: 2
Helix angle: 30°
Radial contour tolerance: ±0.01

Application:

Suitable for machining of high-strength aluminium alloys.

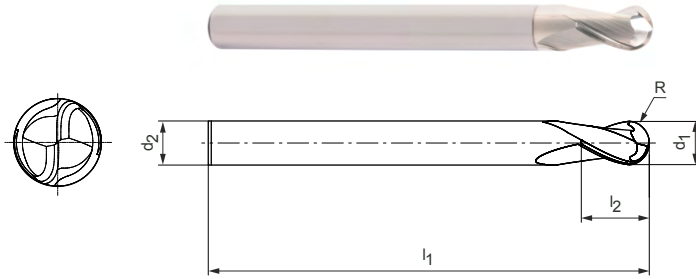

Preferred series in stock

Dimensions					z	Specification	Order no.
d ₁	R	d ₂ h5	l ₁	l ₂			
2,00	1	4	75	4	2	MBN115-020-0100-X075-HP807	31153131
3,00	1,5	4	60	15	2	MBN115-030-0150-X060-HP807	31153132
3,00	1,5	4	75	15	2	MBN115-030-0150-X075-HP807	31153133
4,00	2	4	60	20	2	MBN115-040-0200-X060-HP807	31153134
4,00	2	4	75	20	2	MBN115-040-0200-X075-HP807	31153135
5,00	2,5	6	75	20	2	MBN115-050-0250-X075-HP807	31153136
5,00	2,5	6	100	20	2	MBN115-050-0250-X100-HP807	31153137
6,00	3	6	100	20	2	MBN115-060-0300-X100-HP807	31153138
6,00	3	6	150	20	2	MBN115-060-0300-X150-HP807	31153139
8,00	4	8	100	25	2	MBN115-080-0400-X100-HP807	31153140
8,00	4	8	150	25	2	MBN115-080-0400-X150-HP807	31153141
10,00	5	10	100	25	2	MBN115-100-0500-X100-HP807	31153142
10,00	5	10	150	25	2	MBN115-100-0500-X150-HP807	31153143
12,00	6	12	100	30	2	MBN115-120-0600-X100-HP807	31153144
12,00	6	12	150	30	2	MBN115-120-0600-X150-HP807	31153145
16,00	8	16	100	30	2	MBN115-160-0800-X100-HP807	31153146
16,00	8	16	150	30	2	MBN115-160-0800-X150-HP807	31153147
20,00	10	20	150	35	2	MBN115-200-1000-X150-HP807	31153148

Dimensions in mm.

For cutting data recommendations, see end of chapter.

Special designs and other coatings available upon request.

OptiMill®-3D-BN-Alu

Ball nose milling cutter, design with neck, z=2
MBN116

Design:

Diameter of milling cutter: 1.00 - 20.00 mm
Cutting material: HP807/HU644
Number of cutting edges: 2
Helix angle: 30°
Radial contour tolerance: ±0.01

Application:

Suitable for machining of high-strength aluminium alloys.

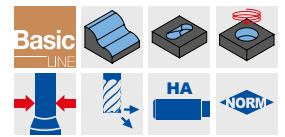
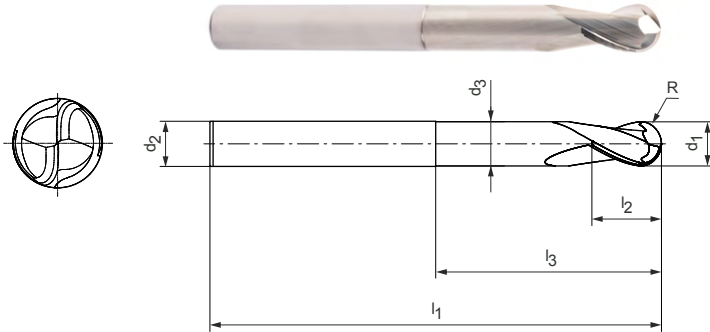

Preferred series in stock

Dimensions							z	Specification	Order no.
d ₁	R	l ₃	d ₂ h5	l ₁	l ₂	d ₃			
1,00	0,5	6	4	50	1,5	0,95	2	MBN116-010-0050-0600X050-HU644	31153149
1,00	0,5	10	4	50	1,5	0,95	2	MBN116-010-0050-1000X050-HU644	31153150
1,00	0,5	15	4	50	1,5	0,95	2	MBN116-010-0050-1500X050-HU644	31153151
1,00	0,5	20	4	75	1,5	0,95	2	MBN116-010-0050-2000X075-HU644	31153152
1,00	0,5	25	4	75	1,5	0,95	2	MBN116-010-0050-2500X075-HU644	31153153
1,00	0,5	30	4	75	1,5	0,95	2	MBN116-010-0050-3000X075-HU644	31153154
1,50	0,75	10	4	50	2,5	1,4	2	MBN116-015-0075-1000X050-HU644	31153155
1,50	0,75	15	4	50	2,5	1,4	2	MBN116-015-0075-1500X050-HU644	31153156
1,50	0,75	20	4	75	2,5	1,4	2	MBN116-015-0075-2000X075-HU644	31153157
1,50	0,75	25	4	75	2,5	1,4	2	MBN116-015-0075-2500X075-HU644	31153158
1,50	0,75	30	4	75	2,5	1,4	2	MBN116-015-0075-3000X075-HU644	31153159
2,00	1	10	4	50	3	1,9	2	MBN116-020-0100-1000X050-HP807	31153160
2,00	1	15	4	50	3	1,9	2	MBN116-020-0100-1500X050-HP807	31153161
2,00	1	20	4	75	3	1,9	2	MBN116-020-0100-2000X075-HP807	31153162
2,00	1	25	4	75	3	1,9	2	MBN116-020-0100-2500X075-HP807	31153163
2,00	1	30	4	75	3	1,9	2	MBN116-020-0100-3000X075-HP807	31153164
2,00	1	35	4	75	3	1,9	2	MBN116-020-0100-3500X075-HP807	31153165
3,00	1,5	10	6	57	4,5	2,9	2	MBN116-030-0150-1000X057-HP807	31153169
3,00	1,5	20	6	57	4,5	2,9	2	MBN116-030-0150-2000X057-HP807	31153180
3,00	1,5	30	6	75	4,5	2,9	2	MBN116-030-0150-3000X075-HP807	31153181
3,00	1,5	40	6	75	4,5	2,9	2	MBN116-030-0150-4000X075-HP807	31153182
4,00	2	10	6	57	6	3,8	2	MBN116-040-0200-1000X057-HP807	31153183
4,00	2	20	6	57	6	3,8	2	MBN116-040-0200-2000X057-HP807	31153184
4,00	2	30	6	75	6	3,8	2	MBN116-040-0200-3000X075-HP807	31153185
4,00	2	40	6	75	6	3,8	2	MBN116-040-0200-4000X075-HP807	31153186
6,00	3	20	6	57	9	5,8	2	MBN116-060-0300-2000X057-HP807	31153187
6,00	3	30	6	75	9	5,8	2	MBN116-060-0300-3000X075-HP807	31153188
6,00	3	40	6	75	9	5,8	2	MBN116-060-0300-4000X075-HP807	31153189
6,00	3	50	6	100	9	5,8	2	MBN116-060-0300-5000X100-HP807	31153190
8,00	4	35	8	90	12	7,8	2	MBN116-080-0400-3500X090-HP807	31153192
8,00	4	50	8	100	12	7,8	2	MBN116-080-0400-5000X100-HP807	31153193
10,00	5	40	10	72	15	9,8	2	MBN116-100-0500-4000X072-HP807	31153195
10,00	5	50	10	100	15	9,8	2	MBN116-100-0500-5000X100-HP807	31153196
12,00	6	40	12	83	18	11,8	2	MBN116-120-0600-4000X083-HP807	31153199
12,00	6	50	12	110	18	11,8	2	MBN116-120-0600-5000X110-HP807	31153200

OptiMill®-3D-BN-Alu | MBN116 | Ball nose milling cutter, design with neck, z=2

Dimensions							z	Specification	Order no.
d ₁	R	l ₃	d ₂ h5	l ₁	l ₂	d ₃			
16,00	8	100	16	150	24	15,8	2	MBN116-160-0800-1000X150-HP807	31153203
20,00	10	100	20	150	30	19,8	2	MBN116-200-1000-1000X150-HP807	31153204

Available on request

2,50	1,25	15	4	50	4	2,4	2	MBN116-025-0125-1500X050-HP807	31153166
2,50	1,25	20	4	75	4	2,4	2	MBN116-025-0125-2000X075-HP807	31153167
2,50	1,25	35	4	75	4	2,4	2	MBN116-025-0125-3500X075-HP807	31153168
6,00	3	70	6	100	9	5,8	2	MBN116-060-0300-7000X100-HP807	31153191
8,00	4	70	8	100	12	7,8	2	MBN116-080-0400-7000X100-HP807	31153194
10,00	5	70	10	100	15	9,8	2	MBN116-100-0500-7000X100-HP807	31153197
10,00	5	100	10	150	15	9,8	2	MBN116-100-0500-1000X150-HP807	31153198
12,00	6	70	12	110	18	11,8	2	MBN116-120-0600-7000X110-HP807	31153201
12,00	6	100	12	150	18	11,8	2	MBN116-120-0600-1000X150-HP807	31153202

Dimensions in mm.

For cutting data recommendations, see end of chapter.

Special designs and other coatings available upon request.

OptiMill®-3D-BN-Copper

Ball nose milling cutter, z=2
MBN113

Design:

Diameter of milling cutter: 1.00 - 16.00 mm
Cutting material: HP804/HU318
Number of cutting edges: 2
Helix angle: 30°
Radial contour tolerance: ±0.01

Application:

Special geometry for machining of copper electrodes and tough non-ferrous alloys.

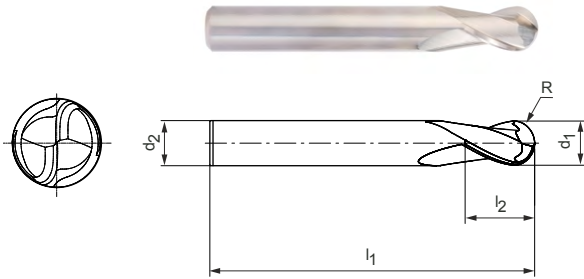

Preferred series in stock

Dimensions					z	Specification	Order no.
d ₁	R	d ₂ h5	l ₁	l ₂			
1,00	0,5	4	50	1,5	2	MBN113-010-0050-X050-HU318	31153061
1,50	0,75	6	57	2,5	2	MBN113-015-0075-X057-HU318	31153062
2,00	1	6	57	3	2	MBN113-020-0100-X057-HP804	31153063
2,50	1,25	6	57	4	2	MBN113-025-0125-X057-HP804	31153064
3,00	1,5	6	57	4,5	2	MBN113-030-0150-X057-HP804	31153065
4,00	2	6	57	6	2	MBN113-040-0200-X057-HP804	31153066
5,00	2,5	6	57	7,5	2	MBN113-050-0250-X057-HP804	31153067
6,00	3	6	57	9	2	MBN113-060-0300-X057-HP804	31153068
8,00	4	8	63	12	2	MBN113-080-0400-X063-HP804	31153069
10,00	5	10	72	15	2	MBN113-100-0500-X072-HP804	31153071
12,00	6	12	83	18	2	MBN113-120-0600-X083-HP804	31153072
16,00	8	16	92	24	2	MBN113-160-0800-X092-HP804	31153073

Dimensions in mm.

For cutting data recommendations, see end of chapter.

Special designs and other coatings available upon request.

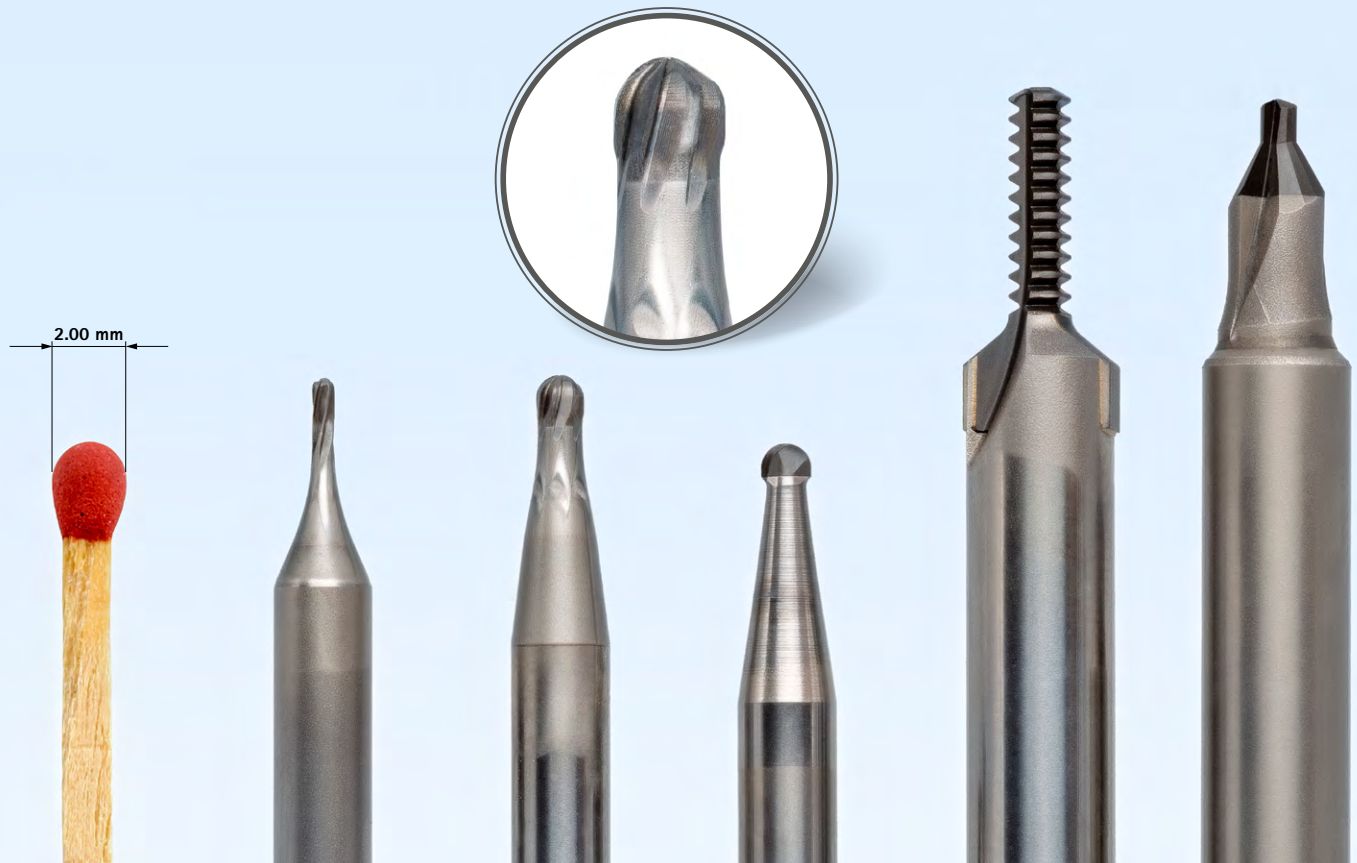

PCD Full Head milling cutters

Machining hard-brittle workpiece materials

To machine stamps and dies, tools with diameters of less than 6 mm are mostly used. Full-head PCD is used to execute these tool dimensions in PCD since smaller milling cutters have no room for brazed-on cutting edges

and their substructure. With a new geometry, number of cutting edges and design, MAPAL makes it possible to machine hard-brittle workpiece materials with diameters from 0.8 to 6 mm with these tools. In addition to car

bide, hard-brittle workpiece materials also include zirconia, a ceramic material used in dental technology. PCD milling cutters are also an alternative to solid carbide in this area.

Comparison: Milling a solid carbide stencil

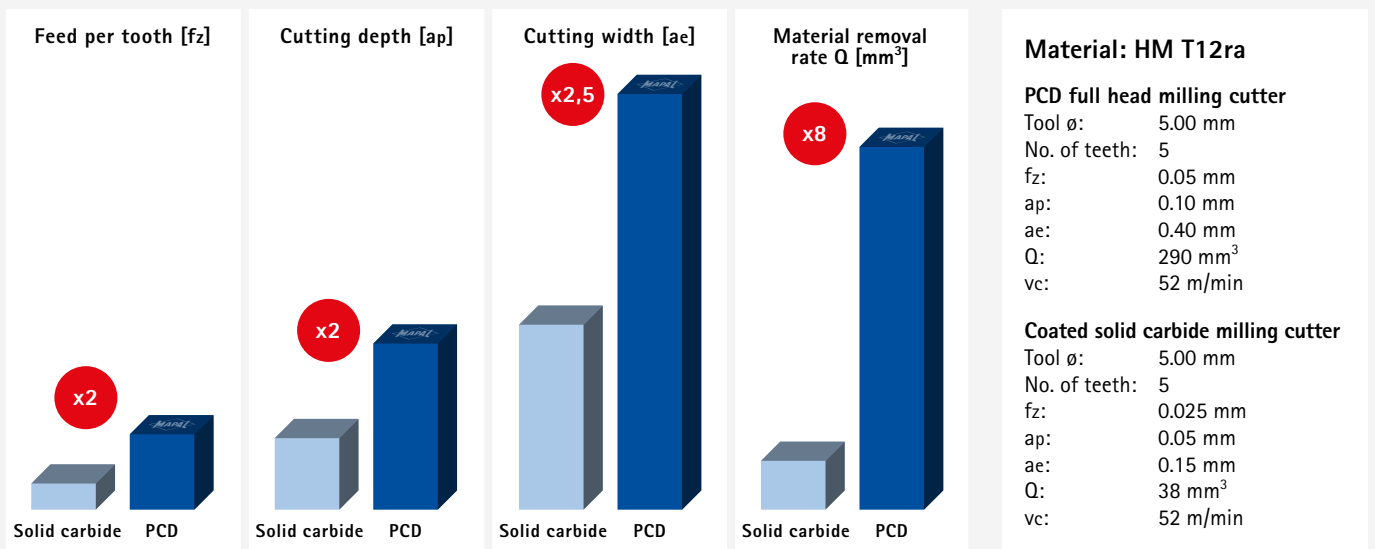

CUSTOM-MADE PCD FULL HEAD MILLING CUTTER



In the die & mould sector, deep-drawing dies are often made from durable carbide. Machining them by die-sinking or grinding is tedious. With new PCD solid head tools, MAPAL is extending the possibility of machining carbide and other hard-brittle materials to smaller diameters.

CUSTOMISED SPECIAL SOLUTIONS

- PCD full head tools available in diameter range from 0.8 to 6 mm
- Individual dimensions
- Variety of geometries
- Different numbers of teeth
- Tools specially adapted to the application

ADVANTAGES

- Longer tool life with shorter process times
- 100% higher feeds per tooth with 8 times higher material removal rates compared to coated solid carbide
- Double cutting depths can be achieved with 2.5 times the cutting width

Cutting data recommendations for ball nose milling cutters

Feed and cutting speed

OptiMill-3D-BN | MBN100, 101, 102, 103, 104, 105

MMG*	Workpiece material	Strength/hardness [N/mm ²] [HRC]	Cooling			
			Dry	Air/MQL	KSS	
P	P1.1	Structural, machining, case hardened and tempering steels, unalloyed	< 700	✓	✓	✓
	P1.2	Structural, machining, case hardened and tempering steels, unalloyed	< 1,200	✓	✓	✓
	P2.1	Nitriding, hardening and tempering steels, alloyed	< 900	✓	✓	✓
	P2.2	Nitriding, hardening and tempering steels, alloyed	< 1,400	✓	✓	✓
	P3.1	Tool, bearing, spring and high-speed steels**	< 800	✓	✓	✓
	P3.2	Tool, bearing, spring and high-speed steels**	< 1,000	✓	✓	✓
	P3.3	Tool, bearing, spring and high-speed steels**	< 1,500	✓	✓	✓
	P4.1	Stainless steels, ferritic and martensitic			✓	✓
	P5.1	Cast steel			✓	✓
	P6.1	Stainless cast steels, ferritic and martensitic			✓	✓
M	M1.1	Stainless steels, austenitic	< 700			✓
	M1.2	Stainless steels, ferritic/austenitic (duplex)	< 1,000			✓
	M2.1	Stainless cast steel, austenitic	< 700			✓
	M3.1	Stainless cast steel, ferritic/austenitic (duplex)	< 1,000			✓
K	K1.1	Cast iron with lamellar graphite (grey cast iron), GJL	< 300	✓	✓	✓
	K2.1	Cast iron with spheroidal graphite, GJS	< 500	✓	✓	✓
	K2.2	Cast iron with spheroidal graphite, GJS	≤ 800	✓	✓	✓
	K2.3	Cast iron with spheroidal graphite, GJS	> 800	✓	✓	✓
	K3.1	Cast iron with vermicular graphite, GJV; malleable cast iron, GJM	< 500	✓	✓	✓
	K3.2	Cast iron with vermicular graphite, GJV; malleable cast iron, GJM	> 500	✓	✓	✓
H	H1.1	Hardened steel / cast steel	< 44 HRC	✓	✓	
	H1.2	Hardened steel / cast steel	< 55 HRC	✓	✓	
	H2.1	Hardened steel / cast steel	< 60 HRC		✓	

Working depth correction factor - k_{AT}

AT	k_{AT}		
	a_p	n	v_f
≤ 3xD	1,00	1,00	1,00
≤ 5xD	0,80	0,90	0,90
≤ 6xD	0,70	0,85	0,85
≤ 8xD	0,60	0,75	0,75
≤ 10xD	0,50	0,70	0,70
≤ 12xD	0,45***	0,65	0,65
≤ 15xD	0,40***	0,60	0,60
≤ 20xD	0,35***	0,60	0,60
≤ 25xD	0,35***	0,50	0,50
≤ 30xD	0,30***	0,50	0,50
≤ 35xD	0,30***	0,50	0,50

Cone angle correction factor - k_{KW}

φ [°]	k_{KW}		
	a_p	n	v_f
0	1,00	1,00	1,00
0,5	1,01	1,01	1,01
1	1,02	1,02	1,02
1,5	1,03	1,03	1,03
3	1,06	1,06	1,06

Note:

To determine cutting data, please observe the notes on page 548-551.

* MAPAL machining groups

** If the alloy parts Cr, Mo, Ni, V, W in total > 8%, then select the next highest MAPAL machining group.

*** Consultation with a MAPAL application engineer.

Roughing

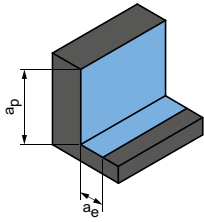

Plunge angle
1.0° - 3.0°

Next page:
Finishing

a_p [mm]	a_e [mm]	V_c [m/min]	f_z [mm]																			
			Diameter of milling cutter [mm]																			
			0.10	0.20	0.30	0.40	0.50	0.60	0.80	1.00	1.50	1.80	2.00	2.50	3.00	4.00	5.00	6.00	8.00	10.00	12.00	16.00
0.05xD	< 0.25xD	250-300	0.003	0.004	0.006	0.008	0.010	0.012	0.016	0.020	0.028	0.035	0.040	0.050	0.061	0.084	0.107	0.125	0.165	0.200	0.235	0.300
0.045xD	< 0.25xD	240-280	0.003	0.004	0.005	0.007	0.009	0.011	0.014	0.018	0.025	0.031	0.035	0.044	0.054	0.074	0.094	0.110	0.145	0.176	0.207	0.264
0.05xD	< 0.25xD	250-300	0.003	0.004	0.006	0.008	0.010	0.012	0.016	0.020	0.028	0.035	0.040	0.050	0.061	0.084	0.107	0.125	0.165	0.200	0.235	0.300
0.045xD	< 0.25xD	240-280	0.003	0.004	0.005	0.007	0.009	0.011	0.014	0.018	0.025	0.031	0.035	0.044	0.054	0.074	0.094	0.110	0.145	0.176	0.207	0.264
0.05xD	< 0.25xD	250-300	0.003	0.004	0.006	0.008	0.010	0.011	0.015	0.019	0.027	0.033	0.038	0.048	0.058	0.080	0.102	0.119	0.157	0.190	0.223	0.285
0.045xD	< 0.2xD	240-280	0.003	0.004	0.005	0.007	0.009	0.011	0.014	0.018	0.025	0.031	0.035	0.044	0.054	0.074	0.094	0.110	0.145	0.176	0.207	0.264
0.04xD	< 0.2xD	220-260	0.002	0.003	0.004	0.006	0.007	0.009	0.012	0.015	0.020	0.026	0.029	0.037	0.045	0.061	0.078	0.091	0.120	0.146	0.172	0.219
0.05xD	< 0.25xD	240-280	0.003	0.004	0.006	0.008	0.010	0.012	0.016	0.020	0.028	0.035	0.040	0.050	0.061	0.084	0.107	0.125	0.165	0.200	0.235	0.300
0.05xD	< 0.25xD	240-280	0.003	0.004	0.005	0.007	0.009	0.011	0.014	0.018	0.025	0.031	0.035	0.044	0.054	0.074	0.094	0.110	0.145	0.176	0.207	0.264
0.045xD	< 0.25xD	200-250	0.002	0.003	0.004	0.006	0.007	0.009	0.012	0.015	0.020	0.026	0.029	0.037	0.045	0.061	0.078	0.091	0.120	0.146	0.172	0.219
0.05xD	< 0.25xD	85-110	0.003	0.004	0.005	0.007	0.009	0.011	0.014	0.018	0.025	0.031	0.035	0.044	0.054	0.074	0.094	0.110	0.145	0.176	0.207	0.264
0.05xD	< 0.25xD	60-85	0.002	0.003	0.004	0.006	0.007	0.009	0.012	0.015	0.020	0.026	0.029	0.037	0.045	0.061	0.078	0.091	0.120	0.146	0.172	0.219
0.05xD	< 0.25xD	85-110	0.003	0.004	0.005	0.007	0.009	0.011	0.014	0.018	0.025	0.031	0.035	0.044	0.054	0.074	0.094	0.110	0.145	0.176	0.207	0.264
0.05xD	< 0.25xD	60-85	0.002	0.003	0.004	0.006	0.007	0.009	0.012	0.015	0.020	0.026	0.029	0.037	0.045	0.061	0.078	0.091	0.120	0.146	0.172	0.219
0.06xD	< 0.3xD	250-300	0.004	0.005	0.007	0.010	0.012	0.014	0.019	0.024	0.034	0.042	0.048	0.060	0.073	0.101	0.128	0.150	0.198	0.240	0.282	0.360
0.06xD	< 0.3xD	250-300	0.003	0.004	0.006	0.008	0.010	0.012	0.016	0.020	0.028	0.035	0.040	0.050	0.061	0.084	0.107	0.125	0.165	0.200	0.235	0.300
0.06xD	< 0.3xD	240-280	0.003	0.004	0.006	0.008	0.010	0.012	0.016	0.020	0.028	0.035	0.040	0.050	0.061	0.084	0.107	0.125	0.165	0.200	0.235	0.300
0.06xD	< 0.3xD	240-280	0.003	0.004	0.005	0.007	0.009	0.011	0.014	0.018	0.025	0.031	0.035	0.044	0.054	0.074	0.094	0.110	0.145	0.176	0.207	0.264
0.06xD	< 0.3xD	250-300	0.002	0.003	0.004	0.006	0.007	0.009	0.012	0.015	0.020	0.026	0.029	0.037	0.045	0.061	0.078	0.091	0.120	0.146	0.172	0.219
0.06xD	< 0.3xD	240-280	0.002	0.002	0.004	0.005	0.006	0.007	0.010	0.012	0.017	0.022	0.025	0.031	0.038	0.052	0.066	0.078	0.102	0.124	0.146	0.186
0.04xD	< 0.18xD	220-280	0.002	0.003	0.004	0.006	0.007	0.009	0.012	0.015	0.020	0.026	0.029	0.037	0.045	0.061	0.078	0.091	0.120	0.146	0.172	0.219
0.03xD	< 0.12xD	160-220	0.002	0.002	0.004	0.005	0.006	0.007	0.010	0.012	0.017	0.021	0.024	0.030	0.037	0.050	0.064	0.075	0.099	0.120	0.141	0.180
0.015xD	< 0.03xD	100-160	0.001	0.002	0.002	0.003	0.004	0.005	0.006	0.008	0.011	0.014	0.016	0.020	0.024	0.034	0.043	0.050	0.066	0.080	0.094	0.120

The specified machining values are guide values.
The optimum data for the respective machining task should be determined during the test or machining.

Cutting data recommendations for ball nose milling cutters

Feed and cutting speed

OptiMill-3D-BN | MBN100, 101, 102, 103, 104, 105

MMG*	Workpiece material	Strength/hardness [N/mm ²] [HRC]	Cooling			
			Dry	Air/MQL	KSS	
P	P1.1	Structural, machining, case hardened and tempering steels, unalloyed	< 700	✓	✓	✓
	P1.2	Structural, machining, case hardened and tempering steels, unalloyed	< 1,200	✓	✓	✓
	P2.1	Nitriding, hardening and tempering steels, alloyed	< 900	✓	✓	✓
	P2.2	Nitriding, hardening and tempering steels, alloyed	< 1,400	✓	✓	✓
	P3.1	Tool, bearing, spring and high-speed steels**	< 800	✓	✓	✓
	P3.2	Tool, bearing, spring and high-speed steels**	< 1,000	✓	✓	✓
	P3.3	Tool, bearing, spring and high-speed steels**	< 1,500	✓	✓	✓
	P4.1	Stainless steels, ferritic and martensitic			✓	✓
	P5.1	Cast steel			✓	✓
	P6.1	Stainless cast steels, ferritic and martensitic			✓	✓
M	M1.1	Stainless steels, austenitic	< 700			✓
	M1.2	Stainless steels, ferritic/austenitic (duplex)	< 1,000			✓
	M2.1	Stainless cast steel, austenitic	< 700			✓
	M3.1	Stainless cast steel, ferritic/austenitic (duplex)	< 1,000			✓
K	K1.1	Cast iron with lamellar graphite (grey cast iron), GJL	< 300	✓	✓	✓
	K2.1	Cast iron with spheroidal graphite, GJS	< 500	✓	✓	✓
	K2.2	Cast iron with spheroidal graphite, GJS	≤ 800	✓	✓	✓
	K2.3	Cast iron with spheroidal graphite, GJS	> 800	✓	✓	✓
	K3.1	Cast iron with vermicular graphite, GJV; malleable cast iron, GJM	< 500	✓	✓	✓
	K3.2	Cast iron with vermicular graphite, GJV; malleable cast iron, GJM	> 500	✓	✓	✓
H	H1.1	Hardened steel / cast steel	< 44 HRC	✓	✓	
	H1.2	Hardened steel / cast steel	< 55 HRC	✓	✓	
	H2.1	Hardened steel / cast steel	< 60 HRC		✓	

Working depth correction factor - k_{AT}

AT	k_{AT}		
	a_p	n	v_f
≤ 3xD	1,00	1,00	1,00
≤ 5xD	0,80	0,90	0,90
≤ 6xD	0,70	0,85	0,85
≤ 8xD	0,60	0,75	0,75
≤ 10xD	0,50	0,70	0,70
≤ 12xD	0,45***	0,65	0,65
≤ 15xD	0,40***	0,60	0,60
≤ 20xD	0,35***	0,60	0,60
≤ 25xD	0,35***	0,50	0,50
≤ 30xD	0,30***	0,50	0,50
≤ 35xD	0,30***	0,50	0,50

Cone angle correction factor - k_{KW}

φ [°]	k_{KW}		
	a_p	n	v_f
0	1,00	1,00	1,00
0,5	1,01	1,01	1,01
1	1,02	1,02	1,02
1,5	1,03	1,03	1,03
3	1,06	1,06	1,06

Note:

To determine cutting data, please observe the notes on page 548-551.

* MAPAL machining groups

** If the alloy parts Cr, Mo, Ni, V, W in total > 8%, then select the next highest MAPAL machining group.

*** Consultation with a MAPAL application engineer.

Finishing

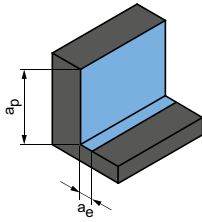

Plunge angle
0.5° - 1.0°

ap [mm]	ae [mm]	Vc [m/min]	fz [mm]																			
			Diameter of milling cutter [mm]																			
			0.10	0.20	0.30	0.40	0.50	0.60	0.80	1.00	1.50	1.80	2.00	2.50	3.00	4.00	5.00	6.00	8.00	10.00	12.00	16.00
0.015xD	0.025xD	280-340	0.003	0.004	0.006	0.008	0.010	0.011	0.015	0.019	0.027	0.033	0.038	0.048	0.058	0.080	0.102	0.119	0.157	0.190	0.223	0.285
0.014xD	0.024xD	280-320	0.003	0.003	0.005	0.007	0.008	0.010	0.013	0.017	0.023	0.029	0.033	0.042	0.051	0.070	0.089	0.105	0.138	0.167	0.196	0.251
0.014xD	0.024xD	270-320	0.003	0.004	0.006	0.008	0.010	0.011	0.015	0.019	0.027	0.033	0.038	0.048	0.058	0.080	0.102	0.119	0.157	0.190	0.223	0.285
0.013xD	0.023xD	260-300	0.003	0.003	0.005	0.007	0.008	0.010	0.013	0.017	0.023	0.029	0.033	0.042	0.051	0.070	0.089	0.105	0.138	0.167	0.196	0.251
0.013xD	0.023xD	280-320	0.003	0.004	0.005	0.007	0.009	0.011	0.014	0.018	0.025	0.032	0.036	0.045	0.055	0.076	0.097	0.113	0.149	0.181	0.212	0.271
0.012xD	0.022xD	260-300	0.002	0.003	0.005	0.006	0.008	0.010	0.013	0.016	0.022	0.028	0.032	0.040	0.048	0.067	0.085	0.099	0.131	0.159	0.187	0.238
0.01xD	0.02xD	240-280	0.002	0.003	0.004	0.006	0.007	0.008	0.011	0.014	0.019	0.024	0.028	0.035	0.042	0.058	0.074	0.087	0.114	0.139	0.163	0.208
0.013xD	0.023xD	260-300	0.003	0.004	0.006	0.008	0.010	0.011	0.015	0.019	0.027	0.033	0.038	0.048	0.058	0.080	0.102	0.119	0.157	0.190	0.223	0.285
0.013xD	0.023xD	260-300	0.003	0.003	0.005	0.007	0.008	0.010	0.013	0.017	0.023	0.029	0.033	0.042	0.051	0.070	0.089	0.105	0.138	0.167	0.196	0.251
0.012xD	0.022xD	220-270	0.002	0.003	0.004	0.006	0.007	0.008	0.011	0.014	0.019	0.024	0.028	0.035	0.042	0.058	0.074	0.087	0.114	0.139	0.163	0.208
0.013xD	0.023xD	90-120	0.003	0.003	0.005	0.007	0.008	0.010	0.013	0.017	0.023	0.029	0.033	0.042	0.051	0.070	0.089	0.105	0.138	0.167	0.196	0.251
0.012xD	0.022xD	70-90	0.002	0.003	0.004	0.006	0.007	0.008	0.011	0.014	0.019	0.024	0.028	0.035	0.042	0.058	0.074	0.087	0.114	0.139	0.163	0.208
0.013xD	0.023xD	90-120	0.003	0.003	0.005	0.007	0.008	0.010	0.013	0.017	0.023	0.029	0.033	0.042	0.051	0.070	0.089	0.105	0.138	0.167	0.196	0.251
0.012xD	0.022xD	70-90	0.002	0.003	0.004	0.006	0.007	0.008	0.011	0.014	0.019	0.024	0.028	0.035	0.042	0.058	0.074	0.087	0.114	0.139	0.163	0.208
0.015xD	0.025xD	280-340	0.003	0.004	0.006	0.008	0.010	0.011	0.015	0.019	0.027	0.033	0.038	0.048	0.058	0.080	0.102	0.119	0.157	0.190	0.223	0.285
0.014xD	0.024xD	280-320	0.003	0.003	0.005	0.007	0.008	0.010	0.013	0.017	0.023	0.029	0.033	0.042	0.051	0.070	0.089	0.105	0.138	0.167	0.196	0.251
0.013xD	0.023xD	270-320	0.003	0.003	0.005	0.007	0.008	0.010	0.013	0.017	0.023	0.029	0.033	0.042	0.051	0.070	0.089	0.105	0.138	0.167	0.196	0.251
0.012xD	0.022xD	260-300	0.003	0.003	0.005	0.007	0.008	0.010	0.013	0.017	0.023	0.029	0.033	0.042	0.051	0.070	0.089	0.105	0.138	0.167	0.196	0.251
0.014xD	0.024xD	280-320	0.002	0.003	0.004	0.006	0.007	0.008	0.011	0.014	0.019	0.024	0.028	0.035	0.042	0.058	0.074	0.087	0.114	0.139	0.163	0.208
0.013xD	0.023xD	260-300	0.002	0.002	0.004	0.005	0.006	0.007	0.009	0.012	0.017	0.021	0.024	0.029	0.036	0.050	0.063	0.074	0.097	0.118	0.139	0.177
0.012xD	0.022xD	240-280	0.002	0.003	0.004	0.006	0.007	0.009	0.012	0.014	0.020	0.025	0.029	0.036	0.044	0.061	0.077	0.090	0.119	0.144	0.170	0.217
0.01xD	0.02xD	160-240	0.002	0.003	0.004	0.005	0.007	0.008	0.011	0.014	0.019	0.024	0.027	0.034	0.042	0.058	0.073	0.086	0.113	0.137	0.161	0.206
0.008xD	0.018xD	120-160	0.001	0.002	0.003	0.004	0.005	0.006	0.008	0.010	0.013	0.017	0.019	0.024	0.029	0.040	0.051	0.060	0.079	0.096	0.113	0.144

The specified machining values are guide values.
The optimum data for the respective machining task should be determined during the test or machining.

Cutting data recommendations for ball nose milling cutters

Feed and cutting speed

OptiMill-3D-BN-Hardened | MBN106, 107, 108, 109

MMG*	Workpiece material	Strength/hardness [N/mm ²] [HRC]	Cooling			
			Dry	Air/MQL	KSS	
P	P1.1	Structural, machining, case hardened and tempering steels, unalloyed	< 700	✓	✓	✓
	P1.2	Structural, machining, case hardened and tempering steels, unalloyed	< 1,200	✓	✓	✓
	P2.1	Nitriding, hardening and tempering steels, alloyed	< 900	✓	✓	✓
	P2.2	Nitriding, hardening and tempering steels, alloyed	< 1,400	✓	✓	✓
	P3.1	Tool, bearing, spring and high-speed steels**	< 800	✓	✓	✓
	P3.2	Tool, bearing, spring and high-speed steels**	< 1,000	✓	✓	✓
	P3.3	Tool, bearing, spring and high-speed steels**	< 1,500	✓	✓	✓
	P4.1	Stainless steels, ferritic and martensitic			✓	✓
	P5.1	Cast steel			✓	✓
	P6.1	Stainless cast steels, ferritic and martensitic			✓	✓
K	K1.1	Cast iron with lamellar graphite (grey cast iron), GJL	< 300	✓	✓	✓
	K2.1	Cast iron with spheroidal graphite, GJS	< 500	✓	✓	✓
	K2.2	Cast iron with spheroidal graphite, GJS	≤ 800	✓	✓	✓
	K2.3	Cast iron with spheroidal graphite, GJS	> 800	✓	✓	✓
	K3.1	Cast iron with vermicular graphite, GJV; malleable cast iron, GJM	< 500	✓	✓	✓
	K3.2	Cast iron with vermicular graphite, GJV; malleable cast iron, GJM	> 500	✓	✓	✓
H	H1.1	Hardened steel / cast steel	< 44 HRC	✓	✓	
	H1.2	Hardened steel / cast steel	< 55 HRC	✓	✓	
	H2.1	Hardened steel / cast steel	< 60 HRC		✓	
	H2.2	Hardened steel / cast steel	< 65 HRC		✓	
	H2.3	Hardened steel / cast steel	< 68 HRC		✓	
	H3.1	Wear-resistant cast / chill casting, GJN		✓	✓	

Working depth correction factor – k_{AT}

AT	k_{AT}		
	a_p	n	v_f
≤ 3xD	1,00	1,00	1,00
≤ 5xD	0,80	0,90	0,90
≤ 6xD	0,70	0,85	0,85
≤ 8xD	0,60	0,75	0,75
≤ 10xD	0,50	0,70	0,70
≤ 12xD	0,45***	0,65	0,65
≤ 15xD	0,40***	0,60	0,60
≤ 20xD	0,35***	0,60	0,60
≤ 25xD	0,35***	0,50	0,50
≤ 30xD	0,30***	0,50	0,50
≤ 35xD	0,30***	0,50	0,50

Cone angle correction factor – k_{KW}

φ [°]	k_{KW}		
	a_p	n	v_f
0	1,00	1,00	1,00
0,5	1,01	1,01	1,01
1	1,02	1,02	1,02
1,5	1,03	1,03	1,03
3	1,06	1,06	1,06

Note:

To determine cutting data, please observe the notes on page 548-551.

* MAPAL machining groups

** If the alloy parts Cr, Mo, Ni, V, W in total > 8%, then select the next highest MAPAL machining group.

*** Consultation with a MAPAL application engineer.

Roughing

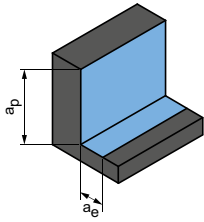

Plunge angle
1.0° - 3.0°

Next page:
Finishing

a_p [mm]	a_e [mm]	v_c [m/min]	f_z [mm]																			
			Diameter of milling cutter [mm]																			
			0.10	0.20	0.30	0.40	0.50	0.60	0.80	1.00	1.50	1.80	2.00	2.50	3.00	4.00	5.00	6.00	8.00	10.00	12.00	16.00
0.05xD	< 0.25xD	250-300	0.003	0.004	0.006	0.008	0.010	0.012	0.016	0.020	0.028	0.035	0.040	0.050	0.061	0.084	0.107	0.125	0.165	0.200	0.235	0.300
0.045xD	< 0.25xD	240-280	0.003	0.004	0.005	0.007	0.009	0.011	0.014	0.018	0.025	0.031	0.035	0.044	0.054	0.074	0.094	0.110	0.145	0.176	0.207	0.264
0.05xD	< 0.25xD	250-300	0.003	0.004	0.006	0.008	0.010	0.012	0.016	0.020	0.028	0.035	0.040	0.050	0.061	0.084	0.107	0.125	0.165	0.200	0.235	0.300
0.045xD	< 0.25xD	240-280	0.003	0.004	0.005	0.007	0.009	0.011	0.014	0.018	0.025	0.031	0.035	0.044	0.054	0.074	0.094	0.110	0.145	0.176	0.207	0.264
0.05xD	< 0.25xD	250-300	0.003	0.004	0.006	0.008	0.010	0.011	0.015	0.019	0.027	0.033	0.038	0.048	0.058	0.080	0.102	0.119	0.157	0.190	0.223	0.285
0.045xD	< 0.2xD	240-280	0.003	0.004	0.005	0.007	0.009	0.011	0.014	0.018	0.025	0.031	0.035	0.044	0.054	0.074	0.094	0.110	0.145	0.176	0.207	0.264
0.04xD	< 0.2xD	220-260	0.002	0.003	0.004	0.006	0.007	0.009	0.012	0.015	0.020	0.026	0.029	0.037	0.045	0.061	0.078	0.091	0.120	0.146	0.172	0.219
0.05xD	< 0.25xD	240-280	0.003	0.004	0.006	0.008	0.010	0.012	0.016	0.020	0.028	0.035	0.040	0.050	0.061	0.084	0.107	0.125	0.165	0.200	0.235	0.300
0.05xD	< 0.25xD	240-280	0.003	0.004	0.005	0.007	0.009	0.011	0.014	0.018	0.025	0.031	0.035	0.044	0.054	0.074	0.094	0.110	0.145	0.176	0.207	0.264
0.045xD	< 0.25xD	200-250	0.002	0.003	0.004	0.006	0.007	0.009	0.012	0.015	0.020	0.026	0.029	0.037	0.045	0.061	0.078	0.091	0.120	0.146	0.172	0.219
0.06xD	< 0.3xD	250-300	0.004	0.005	0.007	0.010	0.012	0.014	0.019	0.024	0.034	0.042	0.048	0.060	0.073	0.101	0.128	0.150	0.198	0.240	0.282	0.360
0.06xD	< 0.3xD	250-300	0.003	0.004	0.006	0.008	0.010	0.012	0.016	0.020	0.028	0.035	0.040	0.050	0.061	0.084	0.107	0.125	0.165	0.200	0.235	0.300
0.06xD	< 0.3xD	240-280	0.003	0.004	0.006	0.008	0.010	0.012	0.016	0.020	0.028	0.035	0.040	0.050	0.061	0.084	0.107	0.125	0.165	0.200	0.235	0.300
0.06xD	< 0.3xD	240-280	0.003	0.004	0.005	0.007	0.009	0.011	0.014	0.018	0.025	0.031	0.035	0.044	0.054	0.074	0.094	0.110	0.145	0.176	0.207	0.264
0.06xD	< 0.3xD	250-300	0.002	0.003	0.004	0.006	0.007	0.009	0.012	0.015	0.020	0.026	0.029	0.037	0.045	0.061	0.078	0.091	0.120	0.146	0.172	0.219
0.06xD	< 0.3xD	240-280	0.002	0.002	0.004	0.005	0.006	0.007	0.010	0.012	0.017	0.022	0.025	0.031	0.038	0.052	0.066	0.078	0.102	0.124	0.146	0.186
0.04xD	< 0.18xD	220-280	0.002	0.003	0.004	0.006	0.007	0.009	0.012	0.015	0.020	0.026	0.029	0.037	0.045	0.061	0.078	0.091	0.120	0.146	0.172	0.219
0.03xD	< 0.12xD	160-220	0.002	0.002	0.004	0.005	0.006	0.007	0.010	0.012	0.017	0.021	0.024	0.030	0.037	0.050	0.064	0.075	0.099	0.120	0.141	0.180
0.015xD	< 0.03xD	100-160	0.001	0.002	0.002	0.003	0.004	0.005	0.006	0.008	0.011	0.014	0.016	0.020	0.024	0.034	0.043	0.050	0.066	0.080	0.094	0.120
0.008xD	< 0.018xD	60-100	0.001	0.001	0.002	0.002	0.003	0.004	0.005	0.006	0.008	0.011	0.012	0.015	0.018	0.025	0.032	0.038	0.050	0.060	0.071	0.090
0.005xD	< 0.015xD	40-80	0.001	0.001	0.001	0.002	0.002	0.003	0.004	0.004	0.006	0.008	0.009	0.011	0.013	0.019	0.024	0.028	0.036	0.044	0.052	0.066
0.015xD	< 0.03xD	100-160	0.001	0.002	0.002	0.003	0.004	0.005	0.006	0.008	0.011	0.014	0.016	0.020	0.024	0.034	0.043	0.050	0.066	0.080	0.094	0.120

The specified machining values are guide values.
The optimum data for the respective machining task should be determined during the test or machining.

Cutting data recommendations for ball nose milling cutters

Feed and cutting speed

OptiMill-3D-BN-Hardened | MBN106, 107, 108, 109

MMG*	Workpiece material	Strength/hardness [N/mm ²] [HRC]	Cooling			
			Dry	Air/MQL	KSS	
P	P1.1	Structural, machining, case hardened and tempering steels, unalloyed	< 700	✓	✓	✓
	P1.2	Structural, machining, case hardened and tempering steels, unalloyed	< 1,200	✓	✓	✓
	P2.1	Nitriding, hardening and tempering steels, alloyed	< 900	✓	✓	✓
	P2.2	Nitriding, hardening and tempering steels, alloyed	< 1,400	✓	✓	✓
	P3.1	Tool, bearing, spring and high-speed steels**	< 800	✓	✓	✓
	P3.2	Tool, bearing, spring and high-speed steels**	< 1,000	✓	✓	✓
	P3.3	Tool, bearing, spring and high-speed steels**	< 1,500	✓	✓	✓
	P4.1	Stainless steels, ferritic and martensitic			✓	✓
	P5.1	Cast steel			✓	✓
	P6.1	Stainless cast steels, ferritic and martensitic			✓	✓
K	K1.1	Cast iron with lamellar graphite (grey cast iron), GJL	< 300	✓	✓	✓
	K2.1	Cast iron with spheroidal graphite, GJS	< 500	✓	✓	✓
	K2.2	Cast iron with spheroidal graphite, GJS	≤ 800	✓	✓	✓
	K2.3	Cast iron with spheroidal graphite, GJS	> 800	✓	✓	✓
	K3.1	Cast iron with vermicular graphite, GJV; malleable cast iron, GJM	< 500	✓	✓	✓
	K3.2	Cast iron with vermicular graphite, GJV; malleable cast iron, GJM	> 500	✓	✓	✓
H	H1.1	Hardened steel / cast steel	< 44 HRC	✓	✓	
	H1.2	Hardened steel / cast steel	< 55 HRC	✓	✓	
	H2.1	Hardened steel / cast steel	< 60 HRC		✓	
	H2.2	Hardened steel / cast steel	< 65 HRC		✓	
	H2.3	Hardened steel / cast steel	< 68 HRC		✓	
	H3.1	Wear-resistant cast / chill casting, GJN		✓	✓	

Working depth correction factor – k_{AT}

AT	k_{AT}		
	a_p	n	v_f
≤ 3xD	1,00	1,00	1,00
≤ 5xD	0,80	0,90	0,90
≤ 6xD	0,70	0,85	0,85
≤ 8xD	0,60	0,75	0,75
≤ 10xD	0,50	0,70	0,70
≤ 12xD	0,45***	0,65	0,65
≤ 15xD	0,40***	0,60	0,60
≤ 20xD	0,35***	0,60	0,60
≤ 25xD	0,35***	0,50	0,50
≤ 30xD	0,30***	0,50	0,50
≤ 35xD	0,30***	0,50	0,50

Cone angle correction factor – k_{KW}

φ [°]	k_{KW}		
	a_p	n	v_f
0	1,00	1,00	1,00
0,5	1,01	1,01	1,01
1	1,02	1,02	1,02
1,5	1,03	1,03	1,03
3	1,06	1,06	1,06

Note:

To determine cutting data, please observe the notes on page 548-551.

* MAPAL machining groups

** If the alloy parts Cr, Mo, Ni, V, W in total > 8%, then select the next highest MAPAL machining group.

*** Consultation with a MAPAL application engineer.

Finishing

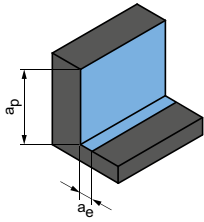

Plunge angle
0.5° - 1.0°

ap [mm]	ae [mm]	Vc [m/min]	fz [mm]																			
			Diameter of milling cutter [mm]																			
			0.10	0.20	0.30	0.40	0.50	0.60	0.80	1.00	1.50	1.80	2.00	2.50	3.00	4.00	5.00	6.00	8.00	10.00	12.00	16.00
0.015xD	0.025xD	280-340	0.003	0.004	0.006	0.008	0.010	0.011	0.015	0.019	0.027	0.033	0.038	0.048	0.058	0.080	0.102	0.119	0.157	0.190	0.223	0.285
0.014xD	0.024xD	280-320	0.003	0.003	0.005	0.007	0.008	0.010	0.013	0.017	0.023	0.029	0.033	0.042	0.051	0.070	0.089	0.105	0.138	0.167	0.196	0.251
0.014xD	0.024xD	270-320	0.003	0.004	0.006	0.008	0.010	0.011	0.015	0.019	0.027	0.033	0.038	0.048	0.058	0.080	0.102	0.119	0.157	0.190	0.223	0.285
0.013xD	0.023xD	260-300	0.003	0.003	0.005	0.007	0.008	0.010	0.013	0.017	0.023	0.029	0.033	0.042	0.051	0.070	0.089	0.105	0.138	0.167	0.196	0.251
0.013xD	0.023xD	280-320	0.003	0.004	0.005	0.007	0.009	0.011	0.014	0.018	0.025	0.032	0.036	0.045	0.055	0.076	0.097	0.113	0.149	0.181	0.212	0.271
0.012xD	0.022xD	260-300	0.003	0.003	0.005	0.007	0.008	0.010	0.013	0.017	0.023	0.029	0.033	0.042	0.051	0.070	0.089	0.105	0.138	0.167	0.196	0.251
0.01xD	0.02xD	240-280	0.002	0.003	0.004	0.006	0.007	0.008	0.011	0.014	0.019	0.024	0.028	0.035	0.042	0.058	0.074	0.087	0.114	0.139	0.163	0.208
0.013xD	0.023xD	260-300	0.003	0.004	0.006	0.008	0.010	0.011	0.015	0.019	0.027	0.033	0.038	0.048	0.058	0.080	0.102	0.119	0.157	0.190	0.223	0.285
0.013xD	0.023xD	260-300	0.003	0.003	0.005	0.007	0.008	0.010	0.013	0.017	0.023	0.029	0.033	0.042	0.051	0.070	0.089	0.105	0.138	0.167	0.196	0.251
0.012xD	0.022xD	220-270	0.002	0.003	0.004	0.006	0.007	0.008	0.011	0.014	0.019	0.024	0.028	0.035	0.042	0.058	0.074	0.087	0.114	0.139	0.163	0.208
0.015xD	0.025xD	280-340	0.003	0.004	0.006	0.008	0.010	0.011	0.015	0.019	0.027	0.033	0.038	0.048	0.058	0.080	0.102	0.119	0.157	0.190	0.223	0.285
0.014xD	0.024xD	280-320	0.003	0.003	0.005	0.007	0.008	0.010	0.013	0.017	0.023	0.029	0.033	0.042	0.051	0.070	0.089	0.105	0.138	0.167	0.196	0.251
0.013xD	0.023xD	270-320	0.003	0.003	0.005	0.007	0.008	0.010	0.013	0.017	0.023	0.029	0.033	0.042	0.051	0.070	0.089	0.105	0.138	0.167	0.196	0.251
0.012xD	0.022xD	260-300	0.003	0.003	0.005	0.007	0.008	0.010	0.013	0.017	0.023	0.029	0.033	0.042	0.051	0.070	0.089	0.105	0.138	0.167	0.196	0.251
0.014xD	0.024xD	280-320	0.002	0.003	0.004	0.006	0.007	0.008	0.011	0.014	0.019	0.024	0.028	0.035	0.042	0.058	0.074	0.087	0.114	0.139	0.163	0.208
0.013xD	0.023xD	260-300	0.002	0.002	0.004	0.005	0.006	0.007	0.009	0.012	0.017	0.021	0.024	0.029	0.036	0.050	0.063	0.074	0.097	0.118	0.139	0.177
0.012xD	0.022xD	250-300	0.003	0.004	0.005	0.007	0.009	0.011	0.015	0.018	0.026	0.032	0.037	0.046	0.056	0.077	0.098	0.114	0.151	0.183	0.215	0.274
0.01xD	0.02xD	200-250	0.002	0.003	0.005	0.007	0.008	0.010	0.013	0.017	0.023	0.029	0.033	0.041	0.051	0.070	0.089	0.104	0.137	0.166	0.195	0.249
0.008xD	0.018xD	130-200	0.002	0.003	0.005	0.006	0.008	0.009	0.012	0.015	0.021	0.026	0.030	0.038	0.046	0.063	0.081	0.094	0.124	0.151	0.177	0.226
0.006xD	0.016xD	100-150	0.002	0.003	0.004	0.005	0.007	0.008	0.011	0.014	0.019	0.024	0.027	0.034	0.042	0.058	0.073	0.086	0.113	0.137	0.161	0.206
0.005xD	0.015xD	70-120	0.001	0.002	0.003	0.004	0.005	0.006	0.008	0.010	0.013	0.017	0.019	0.024	0.029	0.040	0.051	0.060	0.079	0.096	0.113	0.144
0.008xD	0.018xD	130-200	0.002	0.003	0.005	0.006	0.008	0.009	0.012	0.015	0.021	0.026	0.030	0.038	0.046	0.063	0.081	0.094	0.124	0.151	0.177	0.226

The specified machining values are guide values.
The optimum data for the respective machining task should be determined during the test or machining.

Cutting data recommendations for ball nose milling cutters

Feed and cutting speed

OptiMill-3D-BN-Graphite | MBN110, 111

MMG*	Workpiece material	Strength/hardness [N/mm ²] [HRC]	Cooling		
			Dry	Air/MQL	KSS
N N3	N3.1 Graphite, > 8 µm		✓	✓	✓
	N3.2 Graphite, ≤ 8 µm		✓	✓	✓

OptiMill-3D-BN-Graphite | MBN110, 111

MMG*	Workpiece material	Strength/hardness [N/mm ²] [HRC]	Cooling		
			Dry	Air/MQL	KSS
N N3	N3.1 Graphite, > 8 µm		✓	✓	✓
	N3.2 Graphite, ≤ 8 µm		✓	✓	✓

OptiMill-3D-BN-Graphite-MT | MBN112

MMG*	Workpiece material	Strength/hardness [N/mm ²] [HRC]	Cooling		
			Dry	Air/MQL	KSS
N N3	N3.1 Graphite, > 8 µm		✓	✓	✓
	N3.2 Graphite, ≤ 8 µm		✓	✓	✓

Roughing

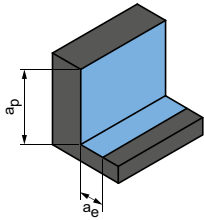

Plunge angle
1.0° - 3.0°

a_p [mm]	a_e [mm]	V_c [m/min]	f_z [mm]																		
			Diameter of milling cutter [mm]																		
			0.20	0.30	0.40	0.50	0.60	0.80	1.00	1.20	1.50	2.00	3.00	4.00	5.00	6.00	8.00	10.00	12.00	16.00	
0.2xD	0.3xD	500-600	0.011	0.013	0.016	0.018	0.019	0.020	0.022	0.030	0.038	0.045	0.057	0.062	0.082	0.090	0.102	0.120	0.155	0.180	
0.2xD	0.3xD	400-500	0.011	0.013	0.016	0.018	0.019	0.020	0.022	0.030	0.038	0.045	0.057	0.062	0.082	0.090	0.102	0.120	0.155	0.180	

Next table:
Finishing (3D, face milling)

Finishing (3D, face milling)

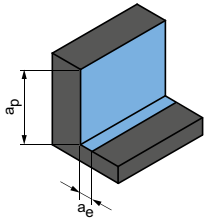

a_p [mm]	a_e [mm]	V_c [m/min]	f_z [mm]																		
			Diameter of milling cutter [mm]																		
			0.20	0.30	0.40	0.50	0.60	0.80	1.00	1.20	1.50	2.00	3.00	4.00	5.00	6.00	8.00	10.00	12.00	16.00	
0.015xD	0.025xD	700-800	0.011	0.013	0.016	0.018	0.019	0.020	0.022	0.030	0.038	0.045	0.057	0.062	0.082	0.090	0.102	0.120	0.155	0.180	
0.015xD	0.025xD	600-700	0.011	0.013	0.016	0.018	0.019	0.020	0.022	0.030	0.038	0.045	0.057	0.062	0.082	0.090	0.102	0.120	0.155	0.180	

Roughing

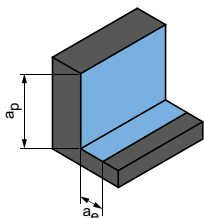

Plunge angle
1.0° - 3.0°

a_p [mm]	a_e [mm]	V_c [m/min]	f_z [mm]						
			Diameter of milling cutter [mm]						
			4.00	5.00	6.00	8.00	10.00	12.00	16.00
1xD	0.2xD	500-600	0.250	0.280	0.300	0.350	0.380	0.400	0.450
1xD	0.2xD	400-500	0.250	0.280	0.300	0.350	0.380	0.400	0.450

The specified machining values are guide values.
The optimum data for the respective machining task should be determined during the test or machining.

Cutting data recommendations for ball nose milling cutters

Feed and cutting speed

OptiMill-Diamond-Radius | SHM52

MMG*	Workpiece material	Strength/hardness [N/mm ²] [HRC]	Cooling			
			Dry	Air/MQL	KSS	
N	N1	N1.1 Aluminium, unalloyed and alloyed < 3% Si	✓	✓	✓	
		N1.2 Aluminium, alloyed ≤ 7% Si	✓	✓	✓	
		N1.3 Aluminium, alloyed > 7 - 12% Si	✓	✓	✓	
		N1.4 Aluminium, alloyed > 12% Si	✓	✓	✓	
	N2	N2.1 Copper, unalloyed and low alloyed	< 300	✓	✓	✓
		N2.2 Copper, alloyed	> 300	✓	✓	✓
		N2.3 Brass, bronze, gunmetal	< 1,200	✓	✓	✓
	N4	N4.1 Plastic, thermoplastics		✓	✓	✓
		N4.2 Plastic, duroplastics		✓	✓	✓
		N4.3 Plastic, foam materials		✓	✓	
	C	C1	C1.1 Plastic range, reinforced with aramid fibre (AFK)	✓	✓	✓
			C1.2 Plastic range (duroplastic), CFK/GFK	✓	✓	✓
			C1.3 Plastic range (thermoplastic), CFK/GFK	✓	✓	✓
C2		C2.1 Carbon range, reinforced with carbon fibre (CFC)		✓	✓	

OptiMill-3D-BN-Alu | MBN114, 115, 116

MMG*	Workpiece material	Strength/hardness [N/mm ²] [HRC]	Cooling			
			Dry	Air/MQL	KSS	
N	N1	N1.1 Aluminium, unalloyed and alloyed < 3% Si			✓	
		N1.2 Aluminium, alloyed ≤ 7% Si			✓	
		N1.3 Aluminium, alloyed > 7 - 12% Si			✓	
		N1.4 Aluminium, alloyed > 12% Si			✓	
	N2	N2.1 Copper, unalloyed and low alloyed	< 300			✓
		N2.2 Copper, alloyed	> 300			✓
		N2.3 Brass, bronze, gunmetal	< 1,200	✓	✓	✓

Finishing

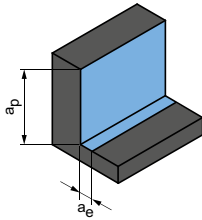

$a_p = 0.1 \times D$
 $a_e = 0.1 \times D$

v_c [m/min]	f_z [mm]								
	Diameter of milling cutter [mm]								
	2.00	4.00	6.00	8.00	10.00	12.00	16.00	20.00	
4.515	0.064	0.113	0.161	0.207	0.252	0.293	0.367	0.367	
3.000	0.067	0.119	0.169	0.218	0.264	0.308	0.385	0.385	
2.400	0.070	0.125	0.177	0.228	0.277	0.322	0.403	0.403	
1.730	0.077	0.136	0.193	0.249	0.302	0.352	0.440	0.440	
1.730	0.051	0.091	0.129	0.166	0.201	0.234	0.293	0.293	
1.295	0.051	0.091	0.129	0.166	0.201	0.234	0.293	0.293	
2.160	0.032	0.057	0.081	0.104	0.126	0.147	0.183	0.183	
595	0.032	0.057	0.081	0.104	0.126	0.147	0.183	0.183	
885	0.032	0.057	0.081	0.104	0.126	0.147	0.183	0.183	
7.195	0.019	0.034	0.048	0.062	0.075	0.088	0.110	0.110	
650	0.045	0.079	0.113	0.145	0.176	0.205	0.257	0.257	
885	0.032	0.057	0.081	0.104	0.126	0.147	0.183	0.183	
595	0.032	0.057	0.081	0.104	0.126	0.147	0.183	0.183	
885	0.029	0.051	0.073	0.093	0.113	0.132	0.165	0.165	

Roughing

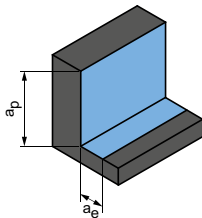

Plunge angle
 $1.0^\circ - 3.0^\circ$

Next page:
Finishing

a_p [mm]	a_e [mm]	v_c [m/min]	f_z [mm]												
			Diameter of milling cutter [mm]												
			1.00	1.50	2.00	2.50	3.00	4.00	5.00	6.00	8.00	10.00	12.00	16.00	20.00
0.1xD	< 0.3xD	400-600	0.022	0.030	0.038	0.045	0.057	0.062	0.082	0.090	0.102	0.120	0.155	0.180	0.205
0.1xD	< 0.3xD	380-580	0.024	0.033	0.042	0.050	0.063	0.068	0.090	0.099	0.112	0.132	0.171	0.198	0.226
0.1xD	< 0.3xD	340-540	0.026	0.036	0.046	0.054	0.068	0.074	0.098	0.108	0.122	0.144	0.186	0.216	0.246
0.1xD	< 0.3xD	300-500	0.029	0.039	0.049	0.059	0.074	0.081	0.107	0.117	0.133	0.156	0.202	0.234	0.267
0.1xD	< 0.3xD	400-500	0.022	0.030	0.038	0.045	0.057	0.062	0.082	0.090	0.102	0.120	0.155	0.180	0.205
0.1xD	< 0.3xD	300-400	0.022	0.030	0.038	0.045	0.057	0.062	0.082	0.090	0.102	0.120	0.155	0.180	0.205
0.1xD	< 0.3xD	400-500	0.026	0.036	0.046	0.054	0.068	0.074	0.098	0.108	0.122	0.144	0.186	0.216	0.246

The specified machining values are guide values.
 The optimum data for the respective machining task should be determined during the test or machining.

Cutting data recommendations for ball nose milling cutters

Feed and cutting speed

OptiMill-3D-BN-Alu | MBN114, 115, 116

MMG*	Workpiece material	Strength/hardness [N/mm ²] [HRC]	Cooling		
			Dry	Air/MQL	KSS
N	N1	N1.1 Aluminium, unalloyed and alloyed < 3% Si			✓
		N1.2 Aluminium, alloyed ≤ 7% Si			✓
		N1.3 Aluminium, alloyed > 7 - 12% Si			✓
		N1.4 Aluminium, alloyed > 12% Si			✓
N	N2	N2.1 Copper, unalloyed and low alloyed	< 300		✓
		N2.2 Copper, alloyed	> 300		✓
		N2.3 Brass, bronze, gunmetal	< 1,200	✓	✓

Working depth correction factor - k_{AT}

AT	k_{AT}		
	a_p	n	v_f
≤ 3xD	1,00	1,00	1,00
≤ 5xD	0,80	0,90	0,90
≤ 6xD	0,70	0,85	0,85
≤ 8xD	0,60	0,75	0,75
≤ 10xD	0,50	0,70	0,70
≤ 12xD	0,45**	0,65	0,65
≤ 15xD	0,40**	0,60	0,60
≤ 20xD	0,35**	0,60	0,60
≤ 25xD	0,35**	0,50	0,50
≤ 30xD	0,30**	0,50	0,50
≤ 35xD	0,30**	0,50	0,50

Cone angle correction factor - k_{KW}

φ [°]	k_{KW}		
	a_p	n	v_f
0	1,00	1,00	1,00
0,5	1,01	1,01	1,01
1	1,02	1,02	1,02
1,5	1,03	1,03	1,03
3	1,06	1,06	1,06

Note:

To determine cutting data, please observe the notes on page 548-551.

* MAPAL machining groups

** Consultation with a MAPAL application engineer.

Finishing

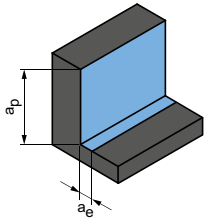

Plunge angle
0.5° - 1.0°

	a_p [mm]	a_e [mm]	v_c [m/min]	f_z [mm]												
				Diameter of milling cutter [mm]												
				1.00	1.50	2.00	2.50	3.00	4.00	5.00	6.00	8.00	10.00	12.00	16.00	20.00
0.015xD	0.025xD	400-600	0.022	0.030	0.038	0.045	0.057	0.062	0.082	0.090	0.102	0.120	0.155	0.180	0.205	
0.015xD	0.025xD	380-580	0.024	0.033	0.042	0.050	0.063	0.068	0.090	0.099	0.112	0.132	0.171	0.198	0.226	
0.015xD	0.025xD	340-540	0.026	0.036	0.046	0.054	0.068	0.074	0.098	0.108	0.122	0.144	0.186	0.216	0.246	
0.015xD	0.025xD	300-500	0.029	0.039	0.049	0.059	0.074	0.081	0.107	0.117	0.133	0.156	0.202	0.234	0.267	
0.015xD	0.025xD	400-500	0.022	0.030	0.038	0.045	0.057	0.062	0.082	0.090	0.102	0.120	0.155	0.180	0.205	
0.015xD	0.025xD	300-400	0.022	0.030	0.038	0.045	0.057	0.062	0.082	0.090	0.102	0.120	0.155	0.180	0.205	
0.015xD	0.025xD	400-500	0.026	0.036	0.046	0.054	0.068	0.074	0.098	0.108	0.122	0.144	0.186	0.216	0.246	

The specified machining values are guide values.

The optimum data for the respective machining task should be determined during the test or machining.

Cutting data recommendations for ball nose milling cutters

Feed and cutting speed

OptiMill-3D-BN-Copper | MBN113

MMG*	Workpiece material	Strength/hardness [N/mm ²] [HRC]	Cooling		
			Dry	Air/MQL	KSS
N	N1	N1.1 Aluminium, unalloyed and alloyed < 3% Si			✓
		N1.2 Aluminium, alloyed ≤ 7% Si			✓
		N1.3 Aluminium, alloyed > 7 - 12% Si			✓
		N1.4 Aluminium, alloyed > 12% Si			✓
N	N2	N2.1 Copper, unalloyed and low alloyed	< 300		✓
		N2.2 Copper, alloyed	> 300		✓
		N2.3 Brass, bronze, gunmetal	< 1,200	✓	✓

OptiMill-3D-BN-Copper | MBN113

MMG*	Workpiece material	Strength/hardness [N/mm ²] [HRC]	Cooling		
			Dry	Air/MQL	KSS
N	N1	N1.1 Aluminium, unalloyed and alloyed < 3% Si			✓
		N1.2 Aluminium, alloyed ≤ 7% Si			✓
		N1.3 Aluminium, alloyed > 7 - 12% Si			✓
		N1.4 Aluminium, alloyed > 12% Si			✓
N	N2	N2.1 Copper, unalloyed and low alloyed	< 300		✓
		N2.2 Copper, alloyed	> 300		✓
		N2.3 Brass, bronze, gunmetal	< 1,200	✓	✓

Working depth correction factor – k_{AT}

AT	k_{AT}		
	a_p	n	v_f
≤ 3xD	1,00	1,00	1,00
≤ 5xD	0,80	0,90	0,90
≤ 6xD	0,70	0,85	0,85
≤ 8xD	0,60	0,75	0,75
≤ 10xD	0,50	0,70	0,70
≤ 12xD	0,45**	0,65	0,65
≤ 15xD	0,40**	0,60	0,60
≤ 20xD	0,35**	0,60	0,60
≤ 25xD	0,35**	0,50	0,50
≤ 30xD	0,30**	0,50	0,50
≤ 35xD	0,30**	0,50	0,50

Cone angle correction factor – k_{KW}

φ [°]	k_{KW}		
	a_p	n	v_f
0	1,00	1,00	1,00
0,5	1,01	1,01	1,01
1	1,02	1,02	1,02
1,5	1,03	1,03	1,03
3	1,06	1,06	1,06

Note:

To determine cutting data, please observe the notes on page 548-551.

* MAPAL machining groups

** Consultation with a MAPAL application engineer.

Roughing

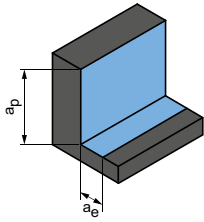

Plunge angle
1.0° - 3.0°

a_p [mm]	a_e [mm]	v_c [m/min]	f_z [mm]													
			Diameter of milling cutter [mm]													
			0.40	1.00	1.50	2.00	2.50	3.00	4.00	5.00	6.00	8.00	10.00	12.00	16.00	
0.1xD	< 0.3xD	400-600	0.016	0.022	0.030	0.038	0.045	0.057	0.062	0.082	0.090	0.102	0.120	0.155	0.180	
0.1xD	< 0.3xD	380-580	0.018	0.024	0.033	0.042	0.050	0.063	0.068	0.090	0.099	0.112	0.132	0.171	0.198	
0.1xD	< 0.3xD	340-540	0.019	0.026	0.036	0.046	0.054	0.068	0.074	0.098	0.108	0.122	0.144	0.186	0.216	
0.1xD	< 0.3xD	300-500	0.021	0.029	0.039	0.049	0.059	0.074	0.081	0.107	0.117	0.133	0.156	0.202	0.234	
0.1xD	< 0.3xD	400-500	0.016	0.022	0.030	0.038	0.045	0.057	0.062	0.082	0.090	0.102	0.120	0.155	0.180	
0.1xD	< 0.3xD	300-400	0.016	0.022	0.030	0.038	0.045	0.057	0.062	0.082	0.090	0.102	0.120	0.155	0.180	
0.1xD	< 0.3xD	400-500	0.019	0.026	0.036	0.046	0.054	0.068	0.074	0.098	0.108	0.122	0.144	0.186	0.216	

Next table:
Finishing

Finishing

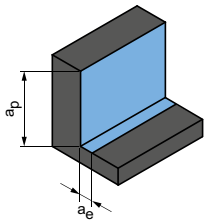

Plunge angle
0.5° - 1.0°

a_p [mm]	a_e [mm]	v_c [m/min]	f_z [mm]													
			Diameter of milling cutter [mm]													
			0.40	1.00	1.50	2.00	2.50	3.00	4.00	5.00	6.00	8.00	10.00	12.00	16.00	
0.015xD	0.025xD	400-600	0.016	0.022	0.030	0.038	0.045	0.057	0.062	0.082	0.090	0.102	0.120	0.155	0.180	
0.015xD	0.025xD	380-580	0.018	0.024	0.033	0.042	0.050	0.063	0.068	0.090	0.099	0.112	0.132	0.171	0.198	
0.015xD	0.025xD	340-540	0.019	0.026	0.036	0.046	0.054	0.068	0.074	0.098	0.108	0.122	0.144	0.186	0.216	
0.015xD	0.025xD	300-500	0.021	0.029	0.039	0.049	0.059	0.074	0.081	0.107	0.117	0.133	0.156	0.202	0.234	
0.015xD	0.025xD	400-500	0.016	0.022	0.030	0.038	0.045	0.057	0.062	0.082	0.090	0.102	0.120	0.155	0.180	
0.015xD	0.025xD	300-400	0.016	0.022	0.030	0.038	0.045	0.057	0.062	0.082	0.090	0.102	0.120	0.155	0.180	
0.015xD	0.025xD	400-500	0.019	0.026	0.036	0.046	0.054	0.068	0.074	0.098	0.108	0.122	0.144	0.186	0.216	

The specified machining values are guide values.

The optimum data for the respective machining task should be determined during the test or machining.



CORNER RADIUS MILLING CUTTERS

Steel, stainless steel and cast iron

OptiMill-3D-CR, z=2	80
OptiMill-3D-CR, design with neck, z=2	81
OptiMill-3D-CR, conical design, z=2	85
OptiMill-3D-CR, z=4	90
OptiMill-3D-CR, design with neck, z=4	91
OptiMill-3D-CR, conical design, z=4	93

Hardened steel

OptiMill-3D-CR-Hardened, z=2	97
OptiMill-3D-CR-Hardened, design with neck, z=2	98
OptiMill-3D-CR-Hardened, z=4	102
OptiMill-3D-CR-Hardened, design with neck, z=4	103
OptiMill-3D-CR-Hardened, design with neck, z=5	105

Graphite, aluminium and copper

OptiMill-3D-CR-Graphite, design with neck, z=2	106
OptiMill-3D-CR-Graphite, design with neck, z=3	108
OptiMill-3D-CR-Graphite, design with neck, z=4	110
OptiMill-Diamond-Torus	111
OptiMill-3D-CR-Alu, z=2	112
OptiMill-3D-CR-Alu, design with neck, z=2	113
OptiMill-3D-CR-Copper, z=2	114
OptiMill-3D-CR-Copper, design with neck, z=2	115

Technical appendix

Cutting data recommendation	116
Determination of cutting data working depth	548

OptiMill®-3D-CR

Corner radius milling cutter, z=2
MCR100

Design:

Diameter of milling cutter: 6.00 - 12.00 mm
Cutting material: HP803
Number of cutting edges: 2
Helix angle: 30°
Radial contour tolerance: ±0.005 if $d_1 \leq 6$ mm
±0.01 if $d_1 > 6$ mm

Application:

Suitable for machining workpiece materials up to 55 HRC.

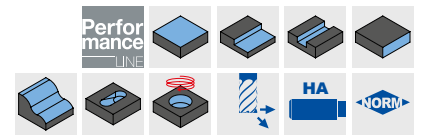
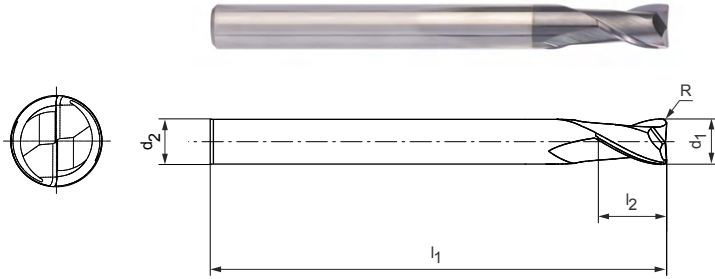

Preferred series in stock

Dimensions					z	Specification	Order no.
d ₁	R	d ₂ h5	l ₁	l ₂			
6,00	0,2	6	60	6,9	2	MCR100-060-0020-X060-HP803	31153808
6,00	0,2	6	100	6,9	2	MCR100-060-0020-X100-HP803	31153809
6,00	0,3	6	60	6,9	2	MCR100-060-0030-X060-HP803	31153810
6,00	0,3	6	100	6,9	2	MCR100-060-0030-X100-HP803	31153811
6,00	0,5	6	75	6,9	2	MCR100-060-0050-X075-HP803	31153812
6,00	0,5	6	100	6,9	2	MCR100-060-0050-X100-HP803	31153813
6,00	1	6	75	6,9	2	MCR100-060-0100-X075-HP803	31153814
6,00	1	6	100	6,9	2	MCR100-060-0100-X100-HP803	31153815
8,00	0,5	8	64	9,2	2	MCR100-080-0050-X064-HP803	31153816
8,00	0,5	8	100	9,2	2	MCR100-080-0050-X100-HP803	31153817
8,00	1	8	64	9,2	2	MCR100-080-0100-X064-HP803	31153818
8,00	1	8	100	9,2	2	MCR100-080-0100-X100-HP803	31153819
8,00	2	8	64	9,2	2	MCR100-080-0200-X064-HP803	31153820
8,00	2	8	100	9,2	2	MCR100-080-0200-X100-HP803	31153821
10,00	0,5	10	75	11,5	2	MCR100-100-0050-X075-HP803	31153822
10,00	0,5	10	120	11,5	2	MCR100-100-0050-X120-HP803	31153823
10,00	1	10	75	11,5	2	MCR100-100-0100-X075-HP803	31153824
10,00	1	10	120	11,5	2	MCR100-100-0100-X120-HP803	31153825
10,00	2	10	75	11,5	2	MCR100-100-0200-X075-HP803	31153826
10,00	2	10	120	11,5	2	MCR100-100-0200-X120-HP803	31153827
12,00	0,5	12	75	13,8	2	MCR100-120-0050-X075-HP803	31153828
12,00	0,5	12	120	13,8	2	MCR100-120-0050-X120-HP803	31153829
12,00	1	12	75	13,8	2	MCR100-120-0100-X075-HP803	31153830
12,00	1	12	120	13,8	2	MCR100-120-0100-X120-HP803	31153831
12,00	2	12	75	13,8	2	MCR100-120-0200-X075-HP803	31153832
12,00	2	12	120	13,8	2	MCR100-120-0200-X120-HP803	31153833

Dimensions in mm.

For cutting data recommendations, see end of chapter.

Special designs and other coatings available upon request.

OptiMill®-3D-CR

Corner radius milling cutter, design with neck, z=2
MCR101

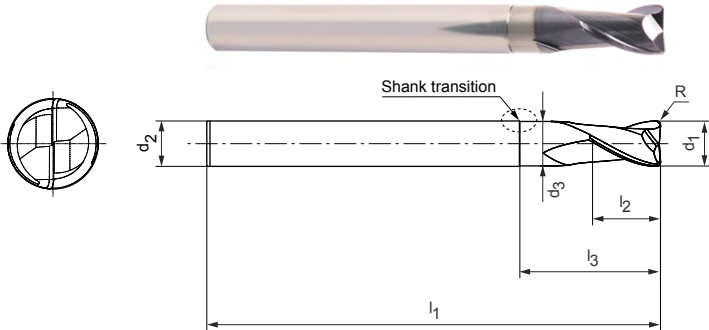

Design:

Diameter of milling cutter: 0.10 - 12.00 mm
Cutting material: HP803/HP819/HP825
Number of cutting edges: 2
Helix angle: 30°
Radial contour tolerance: ±0.005 if d₁ ≤ 6 mm
±0.01 if d₁ > 6 mm

Application:

Suitable for machining workpiece materials up to 55 HRC.

Shank transition:

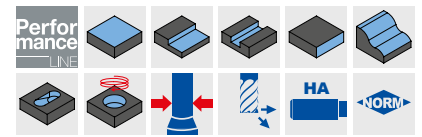
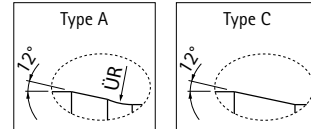

Preferred series in stock

Dimensions						Working depth at x° incline				Type	Specification	Order no.	
d ₁	R	l ₃	d ₂ h5	l ₁	l ₂	d ₃	0.5°	1°	1.5°				3°
0,40	0,1	0,75	4	50	0,5	0,37	1,05	1,11	1,16	1,30	A	MCR101-004-0010-0075X050-HP825	31153854
0,40	0,1	1	4	50	0,5	0,37	1,32	1,39	1,45	1,61	A	MCR101-004-0010-0100X050-HP825	31153855
0,40	0,1	1,5	4	50	0,5	0,37	1,85	1,93	2,01	2,20	A	MCR101-004-0010-0150X050-HP825	31153856
0,40	0,1	2	4	50	0,5	0,37	2,37	2,47	2,56	2,77	A	MCR101-004-0010-0200X050-HP825	31153857
0,40	0,1	2	6	60	0,5	0,37	2,37	2,47	2,56	2,77	A	MCR101-004-0010-0200X060-HP825	31153858
0,40	0,1	3	6	60	0,5	0,37	3,42	3,54	3,65	4,04	A	MCR101-004-0010-0300X060-HP825	31153859
0,50	0,1	1,5	4	50	0,6	0,46	1,88	1,95	2,03	2,21	A	MCR101-005-0010-0150X050-HP825	31153860
0,50	0,1	2	4	50	0,6	0,46	2,40	2,49	2,58	2,79	A	MCR101-005-0010-0200X050-HP825	31153861
0,50	0,1	3	4	50	0,6	0,46	3,44	3,56	3,66	4,07	A	MCR101-005-0010-0300X050-HP825	31153862
0,50	0,1	4	4	50	0,6	0,46	4,48	4,62	4,74	5,40	A	MCR101-005-0010-0400X050-HP825	31153863
0,50	0,1	4	6	60	0,6	0,46	4,48	4,62	4,74	5,40	A	MCR101-005-0010-0400X060-HP825	31153864
0,50	0,1	5	4	50	0,6	0,46	5,51	5,67	5,81	6,73	A	MCR101-005-0010-0500X050-HP825	31153865
0,50	0,1	6	4	50	0,6	0,46	6,55	6,72	6,94	8,06	A	MCR101-005-0010-0600X050-HP825	31153866
0,50	0,1	6	6	60	0,6	0,46	6,55	6,72	6,94	8,06	A	MCR101-005-0010-0600X060-HP825	31153867
0,60	0,1	2	4	50	0,7	0,56	2,40	2,49	2,58	2,79	A	MCR101-006-0010-0200X050-HP825	31153868
0,60	0,1	3	4	50	0,7	0,56	3,44	3,56	3,66	4,07	A	MCR101-006-0010-0300X050-HP825	31153869
0,60	0,1	4	4	50	0,7	0,56	4,48	4,62	4,74	5,40	A	MCR101-006-0010-0400X050-HP825	31153870
0,60	0,1	4	6	60	0,7	0,56	4,48	4,62	4,74	5,40	A	MCR101-006-0010-0400X060-HP825	31153871
0,60	0,1	5	4	50	0,7	0,56	5,51	5,67	5,81	6,73	A	MCR101-006-0010-0500X050-HP825	31153872
0,60	0,1	6	4	50	0,7	0,56	6,55	6,72	6,94	8,06	A	MCR101-006-0010-0600X050-HP825	31153873
0,60	0,1	6	6	60	0,7	0,56	6,55	6,72	6,94	8,06	A	MCR101-006-0010-0600X060-HP825	31153874
0,60	0,1	8	6	60	0,7	0,56	8,61	8,81	9,22	10,71	A	MCR101-006-0010-0800X060-HP825	31153875
0,80	0,1	3	4	50	0,9	0,76	3,44	3,56	3,66	4,07	A	MCR101-008-0010-0300X050-HP825	31153876
0,80	0,1	4	4	50	0,9	0,76	4,48	4,62	4,74	5,40	A	MCR101-008-0010-0400X050-HP825	31153877
0,80	0,1	6	4	50	0,9	0,76	6,55	6,72	6,94	8,06	A	MCR101-008-0010-0600X050-HP825	31153878
0,80	0,1	6	6	60	0,9	0,76	6,55	6,72	6,94	8,06	A	MCR101-008-0010-0600X060-HP825	31153879
0,80	0,1	8	4	50	0,9	0,76	8,61	8,81	9,22	10,71	A	MCR101-008-0010-0800X050-HP825	31153880
0,80	0,1	8	6	60	0,9	0,76	8,61	8,81	9,22	10,71	A	MCR101-008-0010-0800X060-HP825	31153881
0,80	0,1	10	6	60	0,9	0,76	10,66	10,99	11,50	13,37	A	MCR101-008-0010-1000X060-HP825	31153882
1,00	0,2	3	4	50	1,2	0,94	3,48	3,59	3,69	4,11	A	MCR101-010-0020-0300X050-HP825	31153883
1,00	0,2	4	4	50	1,2	0,94	4,52	4,65	4,76	5,43	A	MCR101-010-0020-0400X050-HP825	31153884
1,00	0,2	5	4	50	1,2	0,94	5,55	5,70	5,84	6,76	A	MCR101-010-0020-0500X050-HP825	31153885
1,00	0,2	6	4	50	1,2	0,94	6,58	6,75	6,98	8,09	A	MCR101-010-0020-0600X050-HP825	31153886
1,00	0,2	8	4	50	1,2	0,94	8,64	8,85	9,26	10,74	A	MCR101-010-0020-0800X050-HP825	31153887
1,00	0,2	10	4	50	1,2	0,94	10,69	11,03	11,54	13,40	A	MCR101-010-0020-1000X050-HP825	31153888

OptiMill®-3D-CR | MCR101 | Corner radius milling cutter, design with neck, z=2

Dimensions							Working depth at x° incline				Type	Specification	Order no.
d ₁	R	l ₃	d ₂ h5	l ₁	l ₂	d ₃	0.5°	1°	1.5°	3°			
1,00	0,2	10	6	60	1,2	0,94	10,69	11,03	11,54	13,40	A	MCR101-010-0020-1000X060-HP825	31153889
1,00	0,2	12	6	60	1,2	0,94	12,73	13,21	13,82	16,05	A	MCR101-010-0020-1200X060-HP825	31153890
1,00	0,2	15	6	60	1,2	0,94	15,80	16,48	17,24	20,03	A	MCR101-010-0020-1500X060-HP825	31153891
1,50	0,2	5	4	50	1,7	1,44	5,55	5,70	5,84	6,76	A	MCR101-015-0020-0500X050-HP819	31153892
1,50	0,2	6	4	50	1,7	1,44	6,58	6,75	6,98	8,09	A	MCR101-015-0020-0600X050-HP819	31153893
1,50	0,2	8	4	50	1,7	1,44	8,64	8,85	9,26	10,74	A	MCR101-015-0020-0800X050-HP819	31153894
1,50	0,2	10	4	50	1,7	1,44	10,69	11,03	11,54	13,40	A	MCR101-015-0020-1000X050-HP819	31153895
1,50	0,2	10	6	60	1,7	1,44	10,69	11,03	11,54	13,40	A	MCR101-015-0020-1000X060-HP819	31153896
1,50	0,2	12	4	50	1,7	1,44	12,73	13,21	13,82	16,05	A	MCR101-015-0020-1200X050-HP819	31153897
1,50	0,2	12	6	60	1,7	1,44	12,73	13,21	13,82	16,05	A	MCR101-015-0020-1200X060-HP819	31153898
1,50	0,2	15	4	50	1,7	1,44	15,80	16,48	17,24	20,03	A	MCR101-015-0020-1500X050-HP819	31153899
1,50	0,2	15	6	60	1,7	1,44	15,80	16,48	17,24	20,03	A	MCR101-015-0020-1500X060-HP819	31153900
2,00	0,2	6	4	50	2,3	1,94	7,03	7,35	7,63	8,29	A	MCR101-020-0020-0600X050-HP803	31153906
2,00	0,2	8	4	50	2,3	1,94	9,13	9,51	9,82	10,74	A	MCR101-020-0020-0800X050-HP803	31153907
2,00	0,2	10	4	50	2,3	1,94	11,22	11,64	11,99	13,40	A	MCR101-020-0020-1000X050-HP803	31153908
2,00	0,2	12	4	50	2,3	1,94	13,31	13,77	14,14	16,05	A	MCR101-020-0020-1200X050-HP803	31153909
2,00	0,2	15	4	50	2,3	1,94	16,42	16,94	17,35	19,85	A	MCR101-020-0020-1500X050-HP803	31153910
2,00	0,2	15	6	60	2,3	1,94	16,42	16,94	17,35	20,03	A	MCR101-020-0020-1500X060-HP803	31153911
2,00	0,2	18	4	50	2,3	1,94	19,53	20,09	20,66	22,85	A	MCR101-020-0020-1800X050-HP803	31153912
2,00	0,2	20	4	50	2,3	1,94	21,60	22,19	22,94	24,85	A	MCR101-020-0020-2000X050-HP803	31153913
2,00	0,2	20	6	75	2,3	1,94	21,60	22,19	22,94	26,67	A	MCR101-020-0020-2000X075-HP803	31153914
2,00	0,2	25	6	75	2,3	1,94	26,75	27,41	28,65	33,30	A	MCR101-020-0020-2500X075-HP803	31153915
2,00	0,5	6	4	50	2,3	1,94	7,02	7,33	7,60	8,25	A	MCR101-020-0050-0600X050-HP803	31153916
2,00	0,5	8	4	50	2,3	1,94	9,12	9,49	9,79	10,65	A	MCR101-020-0050-0800X050-HP803	31153917
2,00	0,5	10	4	50	2,3	1,94	11,21	11,63	11,96	13,30	A	MCR101-020-0050-1000X050-HP803	31153918
2,00	0,5	12	4	50	2,3	1,94	13,30	13,75	14,12	15,95	A	MCR101-020-0050-1200X050-HP803	31153919
2,00	0,5	15	4	50	2,3	1,94	16,41	16,92	17,33	19,85	A	MCR101-020-0050-1500X050-HP803	31153920
2,00	0,5	15	6	60	2,3	1,94	16,41	16,92	17,33	19,94	A	MCR101-020-0050-1500X060-HP803	31153921
2,00	0,5	18	4	50	2,3	1,94	19,52	20,08	20,62	22,85	A	MCR101-020-0050-1800X050-HP803	31153922
2,00	0,5	20	4	50	2,3	1,94	21,59	22,18	22,90	24,85	A	MCR101-020-0050-2000X050-HP803	31153923
2,00	0,5	20	6	75	2,3	1,94	21,59	22,18	22,90	26,57	A	MCR101-020-0050-2000X075-HP803	31153924
2,00	0,5	25	6	75	2,3	1,94	26,74	27,40	28,60	33,21	A	MCR101-020-0050-2500X075-HP803	31153925
2,50	0,5	8	4	50	2,9	2,44	9,12	9,49	9,79	10,65	A	MCR101-025-0050-0800X050-HP803	31153926
2,50	0,5	10	4	50	2,9	2,44	11,21	11,63	11,96	13,30	A	MCR101-025-0050-1000X050-HP803	31153927
2,50	0,5	15	4	50	2,9	2,44	16,41	16,92	17,33	18,67	A	MCR101-025-0050-1500X050-HP803	31153928
2,50	0,5	15	6	60	2,9	2,44	16,41	16,92	17,33	19,94	A	MCR101-025-0050-1500X060-HP803	31153929
2,50	0,5	20	4	50	2,9	2,44	21,59	22,18	22,90	23,67	A	MCR101-025-0050-2000X050-HP803	31153930
2,50	0,5	20	6	75	2,9	2,44	21,59	22,18	22,90	26,57	A	MCR101-025-0050-2000X075-HP803	31153932
2,50	0,5	25	6	75	2,9	2,44	26,74	27,40	28,60	33,21	A	MCR101-025-0050-2500X075-HP803	31153933
3,00	0,2	10	6	60	3,5	2,94	11,22	11,64	11,99	13,40	A	MCR101-030-0020-1000X060-HP803	31153934
3,00	0,2	15	6	60	3,5	2,94	16,42	16,94	17,35	20,03	A	MCR101-030-0020-1500X060-HP803	31153935
3,00	0,2	20	6	60	3,5	2,94	21,60	22,19	22,94	26,67	A	MCR101-030-0020-2000X060-HP803	31153936
3,00	0,2	25	6	75	3,5	2,94	26,75	27,41	28,65	32,20	A	MCR101-030-0020-2500X075-HP803	31153937
3,00	0,5	10	6	60	3,5	2,94	11,21	11,63	11,96	13,30	A	MCR101-030-0050-1000X060-HP803	31153938
3,00	0,5	15	6	60	3,5	2,94	16,41	16,92	17,33	19,94	A	MCR101-030-0050-1500X060-HP803	31153939
3,00	0,5	20	6	60	3,5	2,94	21,59	22,18	22,90	26,57	A	MCR101-030-0050-2000X060-HP803	31153940
3,00	0,5	25	6	75	3,5	2,94	26,74	27,40	28,60	32,20	A	MCR101-030-0050-2500X075-HP803	31153941
4,00	0,2	10	6	60	4,6	3,94	11,22	11,64	11,99	13,40	A	MCR101-040-0020-1000X060-HP803	31153942
4,00	0,2	15	6	60	4,6	3,94	16,42	16,94	17,35	19,85	A	MCR101-040-0020-1500X060-HP803	31153943
4,00	0,2	20	6	60	4,6	3,94	21,60	22,19	22,94	24,85	A	MCR101-040-0020-2000X060-HP803	31153944
4,00	0,2	25	6	75	4,6	3,94	26,75	27,41	28,65	29,85	A	MCR101-040-0020-2500X075-HP803	31153945
4,00	0,2	30	6	75	4,6	3,94	31,89	32,82	34,35	34,85	A	MCR101-040-0020-3000X075-HP803	31153946
4,00	0,2	35	6	75	4,6	3,94	37,02	38,27	39,85	-	A	MCR101-040-0020-3500X075-HP803	31153947
4,00	0,5	10	6	60	4,6	3,94	11,21	11,63	11,96	13,30	A	MCR101-040-0050-1000X060-HP803	31153948
4,00	0,5	15	6	60	4,6	3,94	16,41	16,92	17,33	19,85	A	MCR101-040-0050-1500X060-HP803	31153949
4,00	0,5	20	6	60	4,6	3,94	21,59	22,18	22,90	24,85	A	MCR101-040-0050-2000X060-HP803	31153950
4,00	0,5	25	6	75	4,6	3,94	26,74	27,40	28,60	29,85	A	MCR101-040-0050-2500X075-HP803	31153951

OptiMill®-3D-CR | MCR101 | Corner radius milling cutter, design with neck, z=2

Dimensions							Working depth at x° incline				Type	Specification	Order no.
d ₁	R	l ₃	d ₂ h5	l ₁	l ₂	d ₃	0.5°	1°	1.5°	3°			
4,00	0,5	30	6	75	4,6	3,94	31,89	32,79	34,31	34,85	A	MCR101-040-0050-3000X075-HP803	31153952
4,00	0,5	35	6	75	4,6	3,94	37,02	38,24	39,85	-	A	MCR101-040-0050-3500X075-HP803	31153953
5,00	0,2	15	6	60	5,8	4,9	15,88	16,58	17,35	17,59	C	MCR101-050-0020-1500X060-HP803	31153954
5,00	0,2	20	6	60	5,8	4,9	21,09	22,03	22,59	-	C	MCR101-050-0020-2000X060-HP803	31153955
5,00	0,2	25	6	60	5,8	4,9	26,31	27,48	27,59	-	C	MCR101-050-0020-2500X060-HP803	31153956
5,00	0,2	30	6	75	5,8	4,9	31,52	32,59	-	-	C	MCR101-050-0020-3000X075-HP803	31153957
5,00	0,5	15	6	60	5,8	4,9	15,87	16,55	17,31	17,59	C	MCR101-050-0050-1500X060-HP803	31153958
5,00	0,5	20	6	60	5,8	4,9	21,08	22,00	22,59	-	C	MCR101-050-0050-2000X060-HP803	31153959
5,00	0,5	25	6	60	5,8	4,9	26,29	27,45	27,59	-	C	MCR101-050-0050-2500X060-HP803	31153960
5,00	0,5	30	6	75	5,8	4,9	31,51	32,59	-	-	C	MCR101-050-0050-3000X075-HP803	31153961
6,00	0,2	15	6	60	6,9	5,9	-	-	-	-	-	MCR101-060-0020-1500X060-HP803	31153962
6,00	0,2	20	6	60	6,9	5,9	-	-	-	-	-	MCR101-060-0020-2000X060-HP803	31153963
6,00	0,2	25	6	60	6,9	5,9	-	-	-	-	-	MCR101-060-0020-2500X060-HP803	31153964
6,00	0,2	30	6	75	6,9	5,9	-	-	-	-	-	MCR101-060-0020-3000X075-HP803	31153965
6,00	0,2	35	6	75	6,9	5,9	-	-	-	-	-	MCR101-060-0020-3500X075-HP803	31153966
6,00	0,3	15	6	60	6,9	5,9	-	-	-	-	-	MCR101-060-0030-1500X060-HP803	31153967
6,00	0,3	20	6	60	6,9	5,9	-	-	-	-	-	MCR101-060-0030-2000X060-HP803	31153968
6,00	0,3	25	6	60	6,9	5,9	-	-	-	-	-	MCR101-060-0030-2500X060-HP803	31153969
6,00	0,3	30	6	75	6,9	5,9	-	-	-	-	-	MCR101-060-0030-3000X075-HP803	31153970
6,00	0,3	35	6	75	6,9	5,9	-	-	-	-	-	MCR101-060-0030-3500X075-HP803	31153971
6,00	0,5	15	6	60	6,9	5,9	-	-	-	-	-	MCR101-060-0050-1500X060-HP803	31153972
6,00	0,5	20	6	60	6,9	5,9	-	-	-	-	-	MCR101-060-0050-2000X060-HP803	31153973
6,00	0,5	25	6	60	6,9	5,9	-	-	-	-	-	MCR101-060-0050-2500X060-HP803	31153974
6,00	0,5	30	6	75	6,9	5,9	-	-	-	-	-	MCR101-060-0050-3000X075-HP803	31153975
6,00	0,5	35	6	75	6,9	5,9	-	-	-	-	-	MCR101-060-0050-3500X075-HP803	31153976
6,00	1	15	6	60	6,9	5,9	-	-	-	-	-	MCR101-060-0100-1500X060-HP803	31153977
6,00	1	20	6	60	6,9	5,9	-	-	-	-	-	MCR101-060-0100-2000X060-HP803	31153978
6,00	1	25	6	60	6,9	5,9	-	-	-	-	-	MCR101-060-0100-2500X060-HP803	31153979
6,00	1	30	6	75	6,9	5,9	-	-	-	-	-	MCR101-060-0100-3000X075-HP803	31153980
6,00	1	35	6	75	6,9	5,9	-	-	-	-	-	MCR101-060-0100-3500X075-HP803	31153981
8,00	0,5	25	8	64	9,2	7,8	-	-	-	-	-	MCR101-080-0050-2500X064-HP803	31153982
8,00	0,5	50	8	100	9,2	7,8	-	-	-	-	-	MCR101-080-0050-5000X100-HP803	31153983
8,00	1	25	8	64	9,2	7,8	-	-	-	-	-	MCR101-080-0100-2500X064-HP803	31153984
8,00	1	50	8	100	9,2	7,8	-	-	-	-	-	MCR101-080-0100-5000X100-HP803	31153985
8,00	2	25	8	64	9,2	7,8	-	-	-	-	-	MCR101-080-0200-2500X064-HP803	31153986
8,00	2	50	8	100	9,2	7,8	-	-	-	-	-	MCR101-080-0200-5000X100-HP803	31153987
10,00	0,5	30	10	75	11,5	9,8	-	-	-	-	-	MCR101-100-0050-3000X075-HP803	31153988
10,00	0,5	50	10	100	11,5	9,8	-	-	-	-	-	MCR101-100-0050-5000X100-HP803	31153989
10,00	1	30	10	75	11,5	9,8	-	-	-	-	-	MCR101-100-0100-3000X075-HP803	31153990
10,00	1	50	10	100	11,5	9,8	-	-	-	-	-	MCR101-100-0100-5000X100-HP803	31153991
10,00	2	30	10	75	11,5	9,8	-	-	-	-	-	MCR101-100-0200-3000X075-HP803	31153992
10,00	2	50	10	100	11,5	9,8	-	-	-	-	-	MCR101-100-0200-5000X100-HP803	31153993
12,00	0,5	35	12	75	13,8	11,8	-	-	-	-	-	MCR101-120-0050-3500X075-HP803	31153994
12,00	0,5	60	12	100	13,8	11,8	-	-	-	-	-	MCR101-120-0050-6000X100-HP803	31153995
12,00	1	35	12	75	13,8	11,8	-	-	-	-	-	MCR101-120-0100-3500X075-HP803	31153996
12,00	1	60	12	100	13,8	11,8	-	-	-	-	-	MCR101-120-0100-6000X100-HP803	31153997
12,00	2	35	12	75	13,8	11,8	-	-	-	-	-	MCR101-120-0200-3500X075-HP803	31153998
12,00	2	60	12	100	13,8	11,8	-	-	-	-	-	MCR101-120-0200-6000X100-HP803	31153999

Available on request

0,10	0,02	0,3	4	50	0,1	0,075	0,56	0,60	0,64	0,75	A	MCR101-001-0002-0030X050-HP825	31153834
0,10	0,02	0,3	6	60	0,1	0,075	0,56	0,60	0,64	0,75	A	MCR101-001-0002-0030X060-HP825	31153835
0,10	0,02	0,4	4	50	0,1	0,075	0,67	0,71	0,75	0,88	A	MCR101-001-0002-0040X050-HP825	31153836
0,10	0,02	0,4	6	60	0,1	0,075	0,67	0,71	0,75	0,88	A	MCR101-001-0002-0040X060-HP825	31153837
0,20	0,05	0,5	4	50	0,2	0,17	0,79	0,84	0,88	1,01	A	MCR101-002-0005-0050X050-HP825	31153838
0,20	0,05	0,5	6	60	0,2	0,17	0,79	0,84	0,88	1,01	A	MCR101-002-0005-0050X060-HP825	31153839

Continued on next page.

OptiMill®-3D-CR | MCR101 | Corner radius milling cutter, design with neck, z=2

Dimensions							Working depth at x° incline				Type	Specification	Order no.
d ₁	R	l ₃	d ₂ h5	l ₁	l ₂	d ₃	0,5°	1°	1,5°	3°			
0,20	0,05	0,75	4	50	0,2	0,17	1,06	1,12	1,17	1,31	A	MCR101-002-0005-0075X050-HP825	31153840
0,20	0,05	1	4	50	0,2	0,17	1,32	1,39	1,45	1,62	A	MCR101-002-0005-0100X050-HP825	31153841
0,20	0,05	1	6	60	0,2	0,17	1,32	1,39	1,45	1,62	A	MCR101-002-0005-0100X060-HP825	31153842
0,20	0,05	1,25	4	50	0,2	0,17	1,59	1,66	1,73	1,91	A	MCR101-002-0005-0125X050-HP825	31153843
0,20	0,05	1,5	4	50	0,2	0,17	1,85	1,94	2,01	2,20	A	MCR101-002-0005-0150X050-HP825	31153844
0,20	0,05	1,5	6	60	0,2	0,17	1,85	1,94	2,01	2,20	A	MCR101-002-0005-0150X060-HP825	31153845
0,30	0,05	0,5	4	50	0,3	0,27	0,79	0,84	0,88	1,01	A	MCR101-003-0005-0050X050-HP825	31153846
0,30	0,05	0,75	4	50	0,3	0,27	1,06	1,12	1,17	1,31	A	MCR101-003-0005-0075X050-HP825	31153847
0,30	0,05	1	4	50	0,3	0,27	1,32	1,39	1,45	1,62	A	MCR101-003-0005-0100X050-HP825	31153848
0,30	0,05	1	6	60	0,3	0,27	1,32	1,39	1,45	1,62	A	MCR101-003-0005-0100X060-HP825	31153849
0,30	0,05	1,25	4	50	0,3	0,27	1,59	1,66	1,73	1,91	A	MCR101-003-0005-0125X050-HP825	31153850
0,30	0,05	1,5	4	50	0,3	0,27	1,85	1,94	2,01	2,20	A	MCR101-003-0005-0150X050-HP825	31153851
0,30	0,05	1,5	6	60	0,3	0,27	1,85	1,94	2,01	2,20	A	MCR101-003-0005-0150X060-HP825	31153852
0,30	0,05	2	6	60	0,3	0,27	2,37	2,48	2,56	2,78	A	MCR101-003-0005-0200X060-HP825	31153853
1,80	0,2	6	4	50	2,1	1,74	6,58	6,75	6,98	8,09	A	MCR101-018-0020-0600X050-HP819	31153901
1,80	0,2	8	4	50	2,1	1,74	8,64	8,85	9,26	10,74	A	MCR101-018-0020-0800X050-HP819	31153902
1,80	0,2	10	4	50	2,1	1,74	10,69	11,03	11,54	13,40	A	MCR101-018-0020-1000X050-HP819	31153903
1,80	0,2	15	4	50	2,1	1,74	15,80	16,48	17,24	20,03	A	MCR101-018-0020-1500X050-HP819	31153904
1,80	0,2	20	4	50	2,1	1,74	20,99	21,93	22,94	25,32	A	MCR101-018-0020-2000X050-HP819	31153905

Dimensions in mm.

For cutting data recommendations, see end of chapter.

Special designs and other coatings available upon request.

OptiMill®-3D-CR

Corner radius milling cutter, conical design, z=2
MCR102

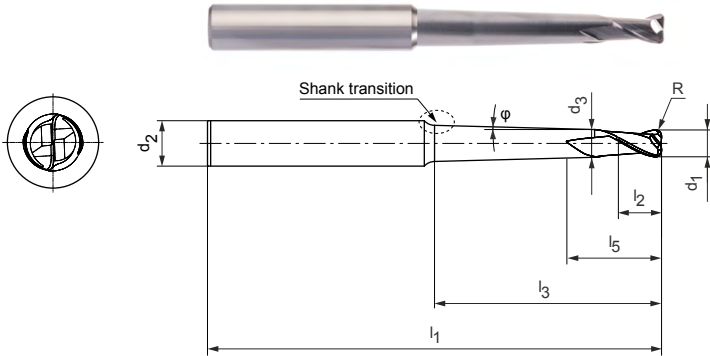

Design:

Diameter of milling cutter: 0.20 - 12.00 mm
Cutting material: HP803/HP825
Number of cutting edges: 2
Helix angle: 30°
Radial contour tolerance: ±0.005 if d₁ ≤ 6 mm
±0.01 if d₁ > 6 mm

Application:

Suitable for machining workpiece materials up to 55 HRC.

Shank transition:

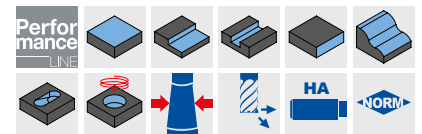
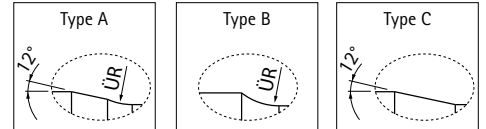

Preferred series in stock

Dimensions						Working depth at x° incline				Type	Specification	Order no.			
d ₁	R	φ [°]	l ₃	d ₂ h5	l ₁	l ₂	d ₃	l ₅	0.5°				1°	1.5°	3°
0,20	0,05	1	1	6	60	0,2	0,17	0,4	1,24	1,33	1,40	1,58	A	MCR102-002-0005-0100B060-HP825	31154000
0,20	0,05	1	1,5	6	60	0,2	0,17	0,4	1,70	1,83	1,92	2,14	A	MCR102-002-0005-0150B060-HP825	31154001
0,20	0,05	1	2	6	60	0,2	0,17	0,4	2,15	2,33	2,44	2,70	A	MCR102-002-0005-0200B060-HP825	31154002
0,30	0,05	0,5	3	6	60	0,3	0,27	0,6	3,30	3,46	3,58	3,93	A	MCR102-003-0005-0300A060-HP825	31154003
0,30	0,05	1	1,5	6	60	0,3	0,27	0,6	1,74	1,85	1,94	2,15	A	MCR102-003-0005-0150B060-HP825	31154004
0,30	0,05	1	2,25	6	60	0,3	0,27	0,6	2,42	2,60	2,72	2,99	A	MCR102-003-0005-0225B060-HP825	31154005
0,30	0,05	1	3	6	60	0,3	0,27	0,6	2,87	3,35	3,50	3,81	A	MCR102-003-0005-0300B060-HP825	31154006
0,40	0,1	0,5	4	6	60	0,5	0,37	0,8	4,31	4,50	4,64	5,20	A	MCR102-004-0010-0400A060-HP825	31154007
0,40	0,1	1	2	6	60	0,5	0,37	0,8	2,22	2,37	2,47	2,71	A	MCR102-004-0010-0200B060-HP825	31154008
0,40	0,1	1	3	6	60	0,5	0,37	0,8	3,11	3,37	3,51	3,81	A	MCR102-004-0010-0300B060-HP825	31154009
0,40	0,1	1	4	6	60	0,5	0,37	0,8	3,22	4,37	4,54	5,02	A	MCR102-004-0010-0400B060-HP825	31154010
0,50	0,1	0,5	5	6	60	0,6	0,46	1	5,35	5,56	5,71	6,51	A	MCR102-005-0010-0500A060-HP825	31154011
0,50	0,1	1	2,5	6	60	0,6	0,46	1	2,76	2,91	3,03	3,29	A	MCR102-005-0010-0250B060-HP825	31154012
0,50	0,1	1	4	6	60	0,6	0,46	1	4,10	4,41	4,58	5,08	A	MCR102-005-0010-0400B060-HP825	31154013
0,50	0,1	1	5	6	60	0,6	0,46	1	4,19	5,41	5,61	6,29	A	MCR102-005-0010-0500B060-HP825	31154014
0,50	0,1	1	7,5	6	60	0,6	0,46	1	4,19	7,91	8,18	9,34	A	MCR102-005-0010-0750B060-HP825	31154015
0,50	0,1	1	10	6	60	0,6	0,46	1	4,19	10,41	10,74	12,38	A	MCR102-005-0010-1000B060-HP825	31154016
0,60	0,1	0,5	6	6	60	0,7	0,56	1,2	6,36	6,60	6,77	7,79	A	MCR102-006-0010-0600A060-HP825	31154017
0,60	0,1	1	3	6	60	0,7	0,56	1,2	3,25	3,43	3,56	3,88	A	MCR102-006-0010-0300B060-HP825	31154018
0,60	0,1	1	4,5	6	60	0,7	0,56	1,2	4,58	4,93	5,10	5,71	A	MCR102-006-0010-0450B060-HP825	31154019
0,60	0,1	1	6	6	60	0,7	0,56	1,2	4,59	6,43	6,65	7,53	A	MCR102-006-0010-0600B060-HP825	31154020
0,60	0,1	1	9	6	60	0,7	0,56	1,2	4,59	9,43	9,72	11,19	A	MCR102-006-0010-0900B060-HP825	31154021
0,60	0,1	1	12	6	60	0,7	0,56	1,2	4,59	12,43	12,79	14,84	A	MCR102-006-0010-1200B060-HP825	31154022
0,80	0,1	0,5	6	6	60	0,9	0,76	1,6	6,38	6,61	6,78	7,82	A	MCR102-008-0010-0600A060-HP825	31154023
0,80	0,1	0,5	8	6	60	0,9	0,76	1,6	8,38	8,66	8,92	10,36	A	MCR102-008-0010-0800A060-HP825	31154024
0,80	0,1	1	4	6	60	0,9	0,76	1,6	4,24	4,46	4,61	5,14	A	MCR102-008-0010-0400B060-HP825	31154025
0,80	0,1	1	6	6	60	0,9	0,76	1,6	5,39	6,46	6,67	7,58	A	MCR102-008-0010-0600B060-HP825	31154026
0,80	0,1	1	8	6	60	0,9	0,76	1,6	5,39	8,46	8,72	10,01	A	MCR102-008-0010-0800B060-HP825	31154027
0,80	0,1	1	12	6	60	0,9	0,76	1,6	5,39	12,46	12,81	14,89	A	MCR102-008-0010-1200B060-HP825	31154028
0,80	0,1	1	16	6	60	0,9	0,76	1,6	5,39	16,46	16,99	19,76	A	MCR102-008-0010-1600B060-HP825	31154029
1,00	0,2	0,5	10	6	60	1,2	0,94	2	10,44	10,75	11,16	12,96	A	MCR102-010-0020-1000A060-HP825	31154030
1,00	0,2	0,5	15	6	60	1,2	0,94	2	15,44	15,90	16,63	19,32	A	MCR102-010-0020-1500A060-HP825	31154031
1,00	0,2	0,5	20	6	75	1,2	0,94	2	20,44	21,12	22,10	25,69	A	MCR102-010-0020-2000A075-HP825	31154032
1,00	0,2	0,5	25	6	75	1,2	0,94	2	25,44	26,34	27,57	32,05	A	MCR102-010-0020-2500A075-HP825	31154033
1,00	0,2	0,5	30	6	75	1,2	0,94	2	30,44	31,57	33,04	38,42	A	MCR102-010-0020-3000A075-HP825	31154034

OptiMill®-3D-CR | MCR102 | Corner radius milling cutter, conical design with working depth, z=2

Dimensions									Working depth at x° incline				Type	Specification	Order no.
d ₁	R	φ [°]	l ₃	d ₂ h5	l ₁	l ₂	d ₃	l ₅	0.5°	1°	1.5°	3°			
1,00	0,2	0,5	35	6	100	1,2	0,94	2	35,44	36,79	38,51	44,78	A	MCR102-010-0020-3500A100-HP825	31154035
1,00	0,2	1	5	6	60	1,2	0,94	2	5,30	5,53	5,69	6,43	A	MCR102-010-0020-0500B060-HP825	31154036
1,00	0,2	1	10	6	60	1,2	0,94	2	7,24	10,53	10,80	12,52	A	MCR102-010-0020-1000B060-HP825	31154037
1,00	0,2	1	15	6	60	1,2	0,94	2	7,24	15,53	16,02	18,62	A	MCR102-010-0020-1500B060-HP825	31154038
1,00	0,2	1	20	6	75	1,2	0,94	2	7,24	20,53	21,26	24,71	A	MCR102-010-0020-2000B075-HP825	31154039
1,00	0,2	1	25	6	75	1,2	0,94	2	7,24	25,53	26,49	30,80	A	MCR102-010-0020-2500B075-HP825	31154040
1,00	0,2	1	30	6	75	1,2	0,94	2	7,24	30,53	31,73	36,89	A	MCR102-010-0020-3000B075-HP825	31154041
1,00	0,2	1	35	6	100	1,2	0,94	2	7,24	35,53	36,96	42,98	A	MCR102-010-0020-3500B100-HP825	31154042
1,00	0,2	1,5	5	6	60	1,2	0,94	2	4,62	5,41	5,60	6,27	A	MCR102-010-0020-0500C060-HP825	31154043
1,00	0,2	1,5	10	6	60	1,2	0,94	2	4,62	9,04	10,60	12,09	A	MCR102-010-0020-1000C060-HP825	31154044
1,00	0,2	1,5	15	6	60	1,2	0,94	2	4,62	9,04	15,60	17,91	A	MCR102-010-0020-1500C060-HP825	31154045
1,00	0,2	1,5	20	6	75	1,2	0,94	2	4,62	9,04	20,60	23,73	A	MCR102-010-0020-2000C075-HP825	31154046
1,00	0,2	1,5	25	6	75	1,2	0,94	2	4,62	9,04	25,60	29,54	A	MCR102-010-0020-2500C075-HP825	31154047
1,00	0,2	1,5	30	6	75	1,2	0,94	2	4,62	9,04	30,60	35,36	A	MCR102-010-0020-3000C075-HP825	31154048
1,00	0,2	1,5	35	6	75	1,2	0,94	2	4,62	9,04	35,60	41,18	A	MCR102-010-0020-3500C075-HP825	31154049
2,00	0,3	0,5	15	6	60	2,3	1,94	4	15,92	16,61	17,08	19,40	A	MCR102-020-0030-1500A060-HP803	31154057
2,00	0,3	0,5	20	6	60	2,3	1,94	4	20,92	21,76	22,32	25,76	A	MCR102-020-0030-2000A060-HP803	31154060
2,00	0,3	0,5	25	6	75	2,3	1,94	4	25,92	26,91	27,65	32,13	A	MCR102-020-0030-2500A075-HP803	31154064
2,00	0,3	0,5	30	6	75	2,3	1,94	4	30,92	32,04	33,12	38,48	A	MCR102-020-0030-3000A075-HP803	31154068
2,00	0,3	0,5	35	6	75	2,3	1,94	4	35,92	37,16	38,59	43,28	A	MCR102-020-0030-3500A075-HP803	31154072
2,00	0,3	1	10	6	60	2,3	1,94	4	10,40	11,17	11,62	12,71	A	MCR102-020-0030-1000B060-HP803	31154055
2,00	0,3	1	15	6	60	2,3	1,94	4	11,14	16,17	16,78	18,80	A	MCR102-020-0030-1500B060-HP803	31154058
2,00	0,3	1	20	6	60	2,3	1,94	4	11,14	21,17	21,92	24,89	A	MCR102-020-0030-2000B060-HP803	31154061
2,00	0,3	1	25	6	75	2,3	1,94	4	11,14	26,17	27,06	30,98	A	MCR102-020-0030-2500B075-HP803	31154065
2,00	0,3	1	30	6	75	2,3	1,94	4	11,14	31,17	32,18	37,08	A	MCR102-020-0030-3000B075-HP803	31154069
2,00	0,3	1	35	6	75	2,3	1,94	4	11,14	36,17	37,30	42,00	A	MCR102-020-0030-3500B075-HP803	31154073
2,00	0,3	1,5	10	6	60	2,3	1,94	4	7,57	10,82	11,39	12,42	A	MCR102-020-0030-1000C060-HP803	31154056
2,00	0,3	1,5	15	6	60	2,3	1,94	4	7,57	14,84	16,39	18,20	A	MCR102-020-0030-1500C060-HP803	31154059
2,00	0,3	1,5	20	6	60	2,3	1,94	4	7,57	14,84	21,39	24,02	A	MCR102-020-0030-2000C060-HP803	31154062
2,00	0,3	1,5	25	6	75	2,3	1,94	4	7,57	14,84	26,39	29,84	A	MCR102-020-0030-2500C075-HP803	31154066
2,00	0,3	1,5	30	6	75	2,3	1,94	4	7,57	14,84	31,39	35,66	A	MCR102-020-0030-3000C075-HP803	31154070
2,00	0,3	1,5	35	6	75	2,3	1,94	4	7,57	14,84	36,39	40,73	A	MCR102-020-0030-3500C075-HP803	31154074
2,00	0,5	0,5	10	6	60	2,3	1,94	4	10,90	11,41	11,79	12,97	A	MCR102-020-0050-1000A060-HP803	31154076
2,00	0,5	0,5	15	6	60	2,3	1,94	4	15,90	16,59	17,07	19,34	A	MCR102-020-0050-1500A060-HP803	31154079
2,00	0,5	0,5	20	6	60	2,3	1,94	4	20,90	21,75	22,31	25,70	A	MCR102-020-0050-2000A060-HP803	31154082
2,00	0,5	0,5	25	6	75	2,3	1,94	4	25,90	26,90	27,62	32,06	A	MCR102-020-0050-2500A075-HP803	31154086
2,00	0,5	0,5	30	6	75	2,3	1,94	4	30,90	32,03	33,09	38,43	A	MCR102-020-0050-3000A075-HP803	31154090
2,00	0,5	0,5	35	6	75	2,3	1,94	4	35,90	37,15	38,56	43,28	A	MCR102-020-0050-3500A075-HP803	31154094
2,00	0,5	1	10	6	60	2,3	1,94	4	10,37	11,15	11,60	12,65	A	MCR102-020-0050-1000B060-HP803	31154077
2,00	0,5	1	15	6	60	2,3	1,94	4	10,94	16,15	16,76	18,74	A	MCR102-020-0050-1500B060-HP803	31154080
2,00	0,5	1	20	6	60	2,3	1,94	4	10,94	21,15	21,91	24,83	A	MCR102-020-0050-2000B060-HP803	31154083
2,00	0,5	1	25	6	75	2,3	1,94	4	10,94	26,15	27,04	30,92	A	MCR102-020-0050-2500B075-HP803	31154087
2,00	0,5	1	30	6	75	2,3	1,94	4	10,94	31,15	32,17	37,01	A	MCR102-020-0050-3000B075-HP803	31154091
2,00	0,5	1	35	6	75	2,3	1,94	4	10,94	36,15	37,29	42,00	A	MCR102-020-0050-3500B075-HP803	31154095
2,00	0,5	1,5	10	6	60	2,3	1,94	4	7,47	10,79	11,37	12,39	A	MCR102-020-0050-1000C060-HP803	31154078
2,00	0,5	1,5	15	6	60	2,3	1,94	4	7,47	14,44	16,37	18,14	A	MCR102-020-0050-1500C060-HP803	31154081
2,00	0,5	1,5	20	6	60	2,3	1,94	4	7,47	14,44	21,37	23,96	A	MCR102-020-0050-2000C060-HP803	31154084
2,00	0,5	1,5	25	6	75	2,3	1,94	4	7,47	14,44	26,37	29,78	A	MCR102-020-0050-2500C075-HP803	31154088
2,00	0,5	1,5	30	6	75	2,3	1,94	4	7,47	14,44	31,37	35,59	A	MCR102-020-0050-3000C075-HP803	31154092
2,00	0,5	1,5	35	6	75	2,3	1,94	4	7,47	14,44	36,37	40,73	A	MCR102-020-0050-3500C075-HP803	31154096
3,00	0,3	0,5	20	6	60	3,5	2,94	6	21,03	21,82	22,36	25,87	A	MCR102-030-0030-2000A060-HP803	31154100
3,00	0,3	0,5	25	6	75	3,5	2,94	6	26,03	26,96	27,74	31,42	A	MCR102-030-0030-2500A075-HP803	31154104
3,00	0,3	0,5	30	6	75	3,5	2,94	6	31,03	32,09	33,21	36,21	A	MCR102-030-0030-3000A075-HP803	31154108
3,00	0,3	0,5	35	6	75	3,5	2,94	6	36,03	37,21	38,68	41,01	A	MCR102-030-0030-3500A075-HP803	31154112
3,00	0,3	0,5	40	6	100	3,5	2,94	6	41,03	42,32	44,15	45,80	A	MCR102-030-0030-4000A100-HP803	31154116
3,00	0,3	1	15	6	60	3,5	2,94	6	15,18	16,35	16,90	19,02	A	MCR102-030-0030-1500B060-HP803	31154098
3,00	0,3	1	20	6	60	3,5	2,94	6	15,14	21,35	22,03	25,11	A	MCR102-030-0030-2000B060-HP803	31154101

OptiMill®-3D-CR | MCR102 | Corner radius milling cutter, conical design with working depth, z=2

Dimensions									Working depth at x° incline				Type	Specification	Order no.
d ₁	R	φ [°]	l ₃	d ₂ h5	l ₁	l ₂	d ₃	l ₅	0.5°	1°	1.5°	3°			
3,00	0,3	1	25	6	75	3,5	2,94	6	15,14	26,35	27,16	30,64	A	MCR102-030-0030-2500B075-HP803	31154105
3,00	0,3	1	30	6	75	3,5	2,94	6	15,14	31,35	32,28	35,23	A	MCR102-030-0030-3000B075-HP803	31154109
3,00	0,3	1	35	6	75	3,5	2,94	6	15,14	36,35	37,39	39,82	A	MCR102-030-0030-3500B075-HP803	31154113
3,00	0,3	1	40	6	100	3,5	2,94	6	15,14	41,35	42,56	44,41	A	MCR102-030-0030-4000B100-HP803	31154117
3,00	0,3	1,5	15	6	60	3,5	2,94	6	10,57	15,89	16,62	18,53	A	MCR102-030-0030-1500C060-HP803	31154099
3,00	0,3	1,5	20	6	60	3,5	2,94	6	10,57	20,42	21,62	24,35	A	MCR102-030-0030-2000C060-HP803	31154102
3,00	0,3	1,5	25	6	75	3,5	2,94	6	10,57	20,84	26,62	29,86	A	MCR102-030-0030-2500C075-HP803	31154106
3,00	0,3	1,5	30	6	75	3,5	2,94	6	10,57	20,84	31,62	34,24	A	MCR102-030-0030-3000C075-HP803	31154110
3,00	0,3	1,5	35	6	75	3,5	2,94	6	10,57	20,84	36,62	37,94	B	MCR102-030-0030-3500C075-HP803	31154114
3,00	0,3	1,5	40	6	75	3,5	2,94	6	10,57	20,84	40,96	43,01	C	MCR102-030-0030-4000C075-HP803	31154118
3,00	0,5	0,5	15	6	60	3,5	2,94	6	16,02	16,66	17,12	19,45	A	MCR102-030-0050-1500A060-HP803	31154120
3,00	0,5	0,5	20	6	60	3,5	2,94	6	21,02	21,81	22,35	25,81	A	MCR102-030-0050-2000A060-HP803	31154123
3,00	0,5	0,5	25	6	75	3,5	2,94	6	26,02	26,95	27,71	31,42	A	MCR102-030-0050-2500A075-HP803	31154127
3,00	0,5	0,5	30	6	75	3,5	2,94	6	31,02	32,08	33,18	36,21	A	MCR102-030-0050-3000A075-HP803	31154131
3,00	0,5	0,5	35	6	75	3,5	2,94	6	36,02	37,20	38,65	41,01	A	MCR102-030-0050-3500A075-HP803	31154135
3,00	0,5	0,5	40	6	100	3,5	2,94	6	41,02	42,31	44,12	45,80	A	MCR102-030-0050-4000A100-HP803	31154139
3,00	0,5	1	15	6	60	3,5	2,94	6	14,94	16,33	16,88	18,96	A	MCR102-030-0050-1500B060-HP803	31154121
3,00	0,5	1	20	6	60	3,5	2,94	6	14,94	21,33	22,02	25,05	A	MCR102-030-0050-2000B060-HP803	31154124
3,00	0,5	1	25	6	75	3,5	2,94	6	14,94	26,33	27,14	30,64	A	MCR102-030-0050-2500B075-HP803	31154128
3,00	0,5	1	30	6	75	3,5	2,94	6	14,94	31,33	32,26	35,23	A	MCR102-030-0050-3000B075-HP803	31154132
3,00	0,5	1	35	6	75	3,5	2,94	6	14,94	36,33	37,37	39,82	A	MCR102-030-0050-3500B075-HP803	31154136
3,00	0,5	1	40	6	100	3,5	2,94	6	14,94	41,33	42,53	44,41	A	MCR102-030-0050-4000B100-HP803	31154140
3,00	0,5	1,5	15	6	60	3,5	2,94	6	10,47	15,86	16,60	18,47	A	MCR102-030-0050-1500C060-HP803	31154122
3,00	0,5	1,5	20	6	60	3,5	2,94	6	10,47	20,34	21,60	24,28	A	MCR102-030-0050-2000C060-HP803	31154125
3,00	0,5	1,5	25	6	75	3,5	2,94	6	10,47	20,44	26,60	29,86	A	MCR102-030-0050-2500C075-HP803	31154129
3,00	0,5	1,5	30	6	75	3,5	2,94	6	10,47	20,44	31,60	34,24	A	MCR102-030-0050-3000C075-HP803	31154133
3,00	0,5	1,5	35	6	75	3,5	2,94	6	10,47	20,44	36,60	37,94	B	MCR102-030-0050-3500C075-HP803	31154137
3,00	0,5	1,5	40	6	75	3,5	2,94	6	10,47	20,44	40,93	43,01	C	MCR102-030-0050-4000C075-HP803	31154141
4,00	0,3	0,5	20	6	60	4,6	3,94	8	21,13	21,88	22,41	24,35	A	MCR102-040-0030-2000A060-HP803	31154143
4,00	0,3	0,5	25	6	75	4,6	3,94	8	26,13	27,01	27,84	29,15	A	MCR102-040-0030-2500A075-HP803	31154146
4,00	0,3	0,5	30	6	75	4,6	3,94	8	31,13	32,14	33,30	33,94	A	MCR102-040-0030-3000A075-HP803	31154150
4,00	0,3	0,5	35	6	75	4,6	3,94	8	36,13	37,25	37,96	37,98	B	MCR102-040-0030-3500A075-HP803	31154154
4,00	0,3	0,5	40	6	75	4,6	3,94	8	41,13	42,36	42,91	-	B	MCR102-040-0030-4000A075-HP803	31154158
4,00	0,3	0,5	45	6	100	4,6	3,94	8	46,13	47,47	47,83	-	B	MCR102-040-0030-4500A100-HP803	31154162
4,00	0,3	0,5	50	6	100	4,6	3,94	8	50,48	52,72	53,12	-	C	MCR102-040-0030-5000A100-HP803	31154166
4,00	0,3	1	20	6	60	4,6	3,94	8	19,14	21,50	22,13	23,86	A	MCR102-040-0030-2000B060-HP803	31154144
4,00	0,3	1	25	6	60	4,6	3,94	8	19,14	26,50	27,25	27,87	B	MCR102-040-0030-2500B060-HP803	31154147
4,00	0,3	1	30	6	75	4,6	3,94	8	19,14	30,84	32,27	33,04	C	MCR102-040-0030-3000B075-HP803	31154151
4,00	0,3	1	35	6	75	4,6	3,94	8	19,14	35,84	37,51	37,63	C	MCR102-040-0030-3500B075-HP803	31154155
4,00	0,3	1	40	6	75	4,6	3,94	8	19,14	40,84	42,22	-	C	MCR102-040-0030-4000B075-HP803	31154159
4,00	0,3	1	45	8	100	4,6	3,94	8	19,14	46,50	47,98	51,51	A	MCR102-040-0030-4500B100-HP803	31154163
4,00	0,3	1	50	8	100	4,6	3,94	8	19,14	51,50	53,21	56,10	A	MCR102-040-0030-5000B100-HP803	31154167
4,00	0,3	1,5	20	6	60	4,6	3,94	8	13,57	20,95	21,81	22,84	B	MCR102-040-0030-2000C060-HP803	31154145
4,00	0,3	1,5	25	6	60	4,6	3,94	8	13,57	25,08	26,24	27,75	C	MCR102-040-0030-2500C060-HP803	31154148
4,00	0,3	1,5	30	8	75	4,6	3,94	8	13,57	26,84	31,81	36,31	A	MCR102-040-0030-3000C075-HP803	31154152
4,00	0,3	1,5	35	8	75	4,6	3,94	8	13,57	26,84	36,81	41,22	A	MCR102-040-0030-3500C075-HP803	31154156
4,00	0,3	1,5	40	8	100	4,6	3,94	8	13,57	26,84	41,81	45,61	A	MCR102-040-0030-4000C100-HP803	31154160
4,00	0,3	1,5	45	8	100	4,6	3,94	8	13,57	26,84	46,81	49,99	A	MCR102-040-0030-4500C100-HP803	31154164
4,00	0,3	1,5	50	8	100	4,6	3,94	8	13,57	26,84	51,81	54,38	A	MCR102-040-0030-5000C100-HP803	31154168
4,00	0,5	0,5	20	6	60	4,6	3,94	8	21,12	21,87	22,40	24,35	A	MCR102-040-0050-2000A060-HP803	31154170
4,00	0,5	0,5	25	6	75	4,6	3,94	8	26,12	27,00	27,81	29,15	A	MCR102-040-0050-2500A075-HP803	31154173
4,00	0,5	0,5	30	6	75	4,6	3,94	8	31,12	32,13	33,28	33,94	A	MCR102-040-0050-3000A075-HP803	31154177
4,00	0,5	0,5	35	6	75	4,6	3,94	8	36,12	37,25	37,95	37,98	B	MCR102-040-0050-3500A075-HP803	31154181
4,00	0,5	0,5	40	6	75	4,6	3,94	8	41,12	42,35	42,91	-	B	MCR102-040-0050-4000A075-HP803	31154185
4,00	0,5	0,5	45	6	100	4,6	3,94	8	46,12	47,46	47,83	-	B	MCR102-040-0050-4500A100-HP803	31154189
4,00	0,5	0,5	50	6	100	4,6	3,94	8	50,47	52,70	53,12	-	C	MCR102-040-0050-5000A100-HP803	31154193
4,00	0,5	1	20	6	60	4,6	3,94	8	18,94	21,49	22,12	23,86	A	MCR102-040-0050-2000B060-HP803	31154171

Continued on next page.

OptiMill®-3D-CR | MCR102 | Corner radius milling cutter, conical design with working depth, z=2

Dimensions									Working depth at x° incline				Type	Specification	Order no.
d ₁	R	φ [°]	l ₃	d ₂ h5	l ₁	l ₂	d ₃	l ₅	0.5°	1°	1.5°	3°			
4,00	0,5	1	25	6	60	4,6	3,94	8	18,94	26,49	27,24	27,87	B	MCR102-040-0050-2500B060-HP803	31154174
4,00	0,5	1	30	6	75	4,6	3,94	8	18,94	30,83	32,25	33,04	C	MCR102-040-0050-3000B075-HP803	31154178
4,00	0,5	1	35	6	75	4,6	3,94	8	18,94	35,83	37,48	37,63	C	MCR102-040-0050-3500B075-HP803	31154182
4,00	0,5	1	40	8	100	4,6	3,94	8	18,94	41,49	42,71	46,92	A	MCR102-040-0050-4000B100-HP803	31154186
4,00	0,5	1	45	8	100	4,6	3,94	8	18,94	46,49	47,95	51,51	A	MCR102-040-0050-4500B100-HP803	31154190
4,00	0,5	1	50	8	100	4,6	3,94	8	18,94	51,49	53,18	56,10	A	MCR102-040-0050-5000B100-HP803	31154194
4,00	0,5	1,5	20	6	60	4,6	3,94	8	13,47	20,93	21,79	22,84	B	MCR102-040-0050-2000C060-HP803	31154172
4,00	0,5	1,5	25	6	60	4,6	3,94	8	13,47	25,06	26,22	27,75	C	MCR102-040-0050-2500C060-HP803	31154175
4,00	0,5	1,5	30	8	75	4,6	3,94	8	13,47	26,44	31,79	36,25	A	MCR102-040-0050-3000C075-HP803	31154179
4,00	0,5	1,5	35	8	75	4,6	3,94	8	13,47	26,44	36,79	41,22	A	MCR102-040-0050-3500C075-HP803	31154183
4,00	0,5	1,5	40	8	100	4,6	3,94	8	13,47	26,44	41,79	45,61	A	MCR102-040-0050-4000C100-HP803	31154187
4,00	0,5	1,5	45	8	100	4,6	3,94	8	13,47	26,44	46,79	49,99	A	MCR102-040-0050-4500C100-HP803	31154191
4,00	0,5	1,5	50	8	100	4,6	3,94	8	13,47	26,44	51,79	54,38	A	MCR102-040-0050-5000C100-HP803	31154195
5,00	0,5	1	30	8	75	5,8	4,9	10	25,23	31,70	32,54	35,65	A	MCR102-050-0050-3000B075-HP803	31154197
5,00	0,5	1	50	8	100	5,8	4,9	10	25,23	51,70	52,86	53,08	B	MCR102-050-0050-5000B100-HP803	31154200
5,00	0,5	1,5	30	8	75	5,8	4,9	10	17,61	30,81	32,02	34,83	A	MCR102-050-0050-3000C075-HP803	31154198
6,00	0,5	1	35	8	75	6,9	5,9	12	29,23	36,29	37,96	38,05	C	MCR102-060-0050-3500B075-HP803	31154202
6,00	0,5	1	40	8	75	6,9	5,9	12	29,23	41,29	42,64	-	C	MCR102-060-0050-4000B075-HP803	31154205
6,00	0,5	1	50	10	100	6,9	5,9	12	29,23	51,82	53,67	56,52	A	MCR102-060-0050-5000B100-HP803	31154208
6,00	0,5	1	60	10	110	6,9	5,9	12	29,23	61,82	64,13	65,70	A	MCR102-060-0050-6000B110-HP803	31154210
6,00	0,5	1,5	35	10	100	6,9	5,9	12	20,61	35,88	37,18	41,81	A	MCR102-060-0050-3500C100-HP803	31154203
6,00	0,5	1,5	40	10	100	6,9	5,9	12	20,61	40,40	42,18	46,20	A	MCR102-060-0050-4000C100-HP803	31154206
6,00	1	1	35	8	75	6,9	5,9	12	28,73	36,24	37,89	38,05	C	MCR102-060-0100-3500B075-HP803	31154212
6,00	1	1	40	8	75	6,9	5,9	12	28,73	41,24	42,64	-	C	MCR102-060-0100-4000B075-HP803	31154215
6,00	1	1	50	10	100	6,9	5,9	12	28,73	51,79	53,60	56,52	A	MCR102-060-0100-5000B100-HP803	31154218
6,00	1	1	60	10	110	6,9	5,9	12	28,73	61,79	64,06	65,70	A	MCR102-060-0100-6000B110-HP803	31154220
6,00	1	1,5	35	10	100	6,9	5,9	12	20,36	35,81	37,14	41,81	A	MCR102-060-0100-3500C100-HP803	31154213
6,00	1	1,5	40	10	100	6,9	5,9	12	20,36	39,74	42,14	46,20	A	MCR102-060-0100-4000C100-HP803	31154216
8,00	0,5	1	50	12	100	9,2	7,8	16	42,96	52,18	54,31	57,09	A	MCR102-080-0050-5000B100-HP803	31154222
8,00	0,5	1	70	12	120	9,2	7,8	16	42,96	72,18	75,25	75,45	A	MCR102-080-0050-7000B120-HP803	31154224
8,00	0,5	1	90	12	140	9,2	7,8	16	42,96	91,90	93,80	-	C	MCR102-080-0050-9000B140-HP803	31154226
8,00	1	1	50	12	100	9,2	7,8	16	42,46	52,15	54,24	57,09	A	MCR102-080-0100-5000B100-HP803	31154228
8,00	1	1	70	12	120	9,2	7,8	16	42,46	72,15	75,18	75,45	A	MCR102-080-0100-7000B120-HP803	31154230
8,00	1	1	90	12	140	9,2	7,8	16	42,46	91,86	93,80	-	C	MCR102-080-0100-9000B140-HP803	31154232
10,00	1	1	50	16	115	11,5	9,8	20	50,28	52,33	54,61	62,12	A	MCR102-100-0100-5000B115-HP803	31154234
10,00	1	1	70	16	130	11,5	9,8	20	50,46	72,33	75,55	80,48	A	MCR102-100-0100-7000B130-HP803	31154236
10,00	1	1	90	16	150	11,5	9,8	20	50,46	92,33	96,49	98,84	A	MCR102-100-0100-9000B150-HP803	31154238
10,00	2	1	50	16	115	11,5	9,8	20	49,46	52,29	54,47	62,12	A	MCR102-100-0200-5000B115-HP803	31154239
10,00	2	1	70	16	130	11,5	9,8	20	49,46	72,29	75,41	80,48	A	MCR102-100-0200-7000B130-HP803	31154241
10,00	2	1	90	16	150	11,5	9,8	20	49,46	92,29	96,35	98,84	A	MCR102-100-0200-9000B150-HP803	31154243
12,00	1	1	50	16	110	13,8	11,8	24	50,99	52,57	54,99	57,74	A	MCR102-120-0100-5000B110-HP803	31154244
12,00	1	1	70	16	125	13,8	11,8	24	58,46	72,50	73,60	73,73	B	MCR102-120-0100-7000B125-HP803	31154246
12,00	1	1	90	16	145	13,8	11,8	24	58,46	92,50	93,24	-	B	MCR102-120-0100-9000B145-HP803	31154247
12,00	2	1	50	16	110	13,8	11,8	24	50,94	52,48	54,85	57,74	A	MCR102-120-0200-5000B110-HP803	31154248
12,00	2	1	70	16	125	13,8	11,8	24	57,46	72,46	73,56	73,73	B	MCR102-120-0200-7000B125-HP803	31154250
12,00	2	1	90	16	145	13,8	11,8	24	57,46	92,46	93,24	-	B	MCR102-120-0200-9000B145-HP803	31154251

Available on request

1,00	0,2	3	15	6	60	1,2	0,94	2	3,05	3,76	4,94	15,80	A	MCR102-010-0020-1500D060-HP825	31154050
1,00	0,2	3	20	6	60	1,2	0,94	2	3,05	3,76	4,94	20,80	A	MCR102-010-0020-2000D060-HP825	31154051
1,00	0,2	3	25	6	75	1,2	0,94	2	3,05	3,76	4,94	25,80	A	MCR102-010-0020-2500D075-HP825	31154052
1,00	0,2	3	30	6	75	1,2	0,94	2	3,05	3,76	4,94	30,80	A	MCR102-010-0020-3000D075-HP825	31154053
1,00	0,2	3	35	6	75	1,2	0,94	2	3,05	3,76	4,94	35,80	A	MCR102-010-0020-3500D075-HP825	31154054
2,00	0,3	3	20	6	60	2,3	1,94	4	5,43	6,71	8,84	21,95	A	MCR102-020-0030-2000D060-HP803	31154063
2,00	0,3	3	25	6	75	2,3	1,94	4	5,43	6,71	8,84	26,95	A	MCR102-020-0030-2500D075-HP803	31154067
2,00	0,3	3	30	6	75	2,3	1,94	4	5,43	6,71	8,84	31,40	C	MCR102-020-0030-3000D075-HP803	31154071

OptiMill®-3D-CR | MCR102 | Corner radius milling cutter, conical design with working depth, z=2

Dimensions									Working depth at x° incline				Type	Specification	Order no.
d ₁	R	φ [°]	l ₃	d ₂ h5	l ₁	l ₂	d ₃	l ₅	0.5°	1°	1.5°	3°			
2,00	0,3	3	35	8	75	2,3	1,94	4	5,43	6,71	8,84	36,95	A	MCR102-020-0030-3500D075-HP803	31154075
2,00	0,5	3	20	6	60	2,3	1,94	4	5,39	6,61	8,65	21,92	A	MCR102-020-0050-2000D060-HP803	31154085
2,00	0,5	3	25	6	75	2,3	1,94	4	5,39	6,61	8,65	26,92	A	MCR102-020-0050-2500D075-HP803	31154089
2,00	0,5	3	30	6	75	2,3	1,94	4	5,39	6,61	8,65	31,34	C	MCR102-020-0050-3000D075-HP803	31154093
2,00	0,5	3	35	8	75	2,3	1,94	4	5,39	6,61	8,65	36,92	A	MCR102-020-0050-3500D075-HP803	31154097
3,00	0,3	3	20	6	60	3,5	2,94	6	7,83	9,71	12,84	22,28	B	MCR102-030-0030-2000D060-HP803	31154103
3,00	0,3	3	25	6	60	3,5	2,94	6	7,83	9,71	12,84	27,06	C	MCR102-030-0030-2500D060-HP803	31154107
3,00	0,3	3	30	8	75	3,5	2,94	6	7,83	9,71	12,84	32,28	A	MCR102-030-0030-3000D075-HP803	31154111
3,00	0,3	3	35	8	75	3,5	2,94	6	7,83	9,71	12,84	37,28	A	MCR102-030-0030-3500D075-HP803	31154115
3,00	0,3	3	40	8	75	3,5	2,94	6	7,83	9,71	12,84	42,28	B	MCR102-030-0030-4000D075-HP803	31154119
3,00	0,5	3	20	6	60	3,5	2,94	6	7,79	9,61	12,64	22,25	B	MCR102-030-0050-2000D060-HP803	31154126
3,00	0,5	3	25	6	60	3,5	2,94	6	7,79	9,61	12,64	26,99	C	MCR102-030-0050-2500D060-HP803	31154130
3,00	0,5	3	30	8	75	3,5	2,94	6	7,79	9,61	12,64	32,25	A	MCR102-030-0050-3000D075-HP803	31154134
3,00	0,5	3	35	8	75	3,5	2,94	6	7,79	9,61	12,64	37,25	A	MCR102-030-0050-3500D075-HP803	31154138
3,00	0,5	3	40	8	75	3,5	2,94	6	7,79	9,61	12,64	42,25	B	MCR102-030-0050-4000D075-HP803	31154142
4,00	0,3	3	25	8	64	4,6	3,94	8	10,23	12,70	16,84	27,71	A	MCR102-040-0030-2500D064-HP803	31154149
4,00	0,3	3	30	8	75	4,6	3,94	8	10,23	12,70	16,84	32,55	B	MCR102-040-0030-3000D075-HP803	31154153
4,00	0,3	3	35	8	75	4,6	3,94	8	10,23	12,70	16,84	37,71	C	MCR102-040-0030-3500D075-HP803	31154157
4,00	0,3	3	40	10	100	4,6	3,94	8	10,23	12,70	16,84	42,71	A	MCR102-040-0030-4000D100-HP803	31154161
4,00	0,3	3	45	10	100	4,6	3,94	8	10,23	12,70	16,84	47,71	A	MCR102-040-0030-4500D100-HP803	31154165
4,00	0,3	3	50	10	100	4,6	3,94	8	10,23	12,70	16,84	52,55	B	MCR102-040-0030-5000D100-HP803	31154169
4,00	0,5	3	25	8	64	4,6	3,94	8	10,19	12,61	16,64	27,65	A	MCR102-040-0050-2500D064-HP803	31154176
4,00	0,5	3	30	8	75	4,6	3,94	8	10,19	12,61	16,64	32,52	B	MCR102-040-0050-3000D075-HP803	31154180
4,00	0,5	3	35	8	75	4,6	3,94	8	10,19	12,61	16,64	37,65	C	MCR102-040-0050-3500D075-HP803	31154184
4,00	0,5	3	40	10	100	4,6	3,94	8	10,19	12,61	16,64	42,65	A	MCR102-040-0050-4000D100-HP803	31154188
4,00	0,5	3	45	10	100	4,6	3,94	8	10,19	12,61	16,64	47,65	A	MCR102-040-0050-4500D100-HP803	31154192
4,00	0,5	3	50	10	100	4,6	3,94	8	10,19	12,61	16,64	52,52	B	MCR102-040-0050-5000D100-HP803	31154196
5,00	0,5	3	30	10	75	5,8	4,9	10	13,04	16,18	21,40	33,43	A	MCR102-050-0050-3000D075-HP803	31154199
5,00	0,5	3	50	12	100	5,8	4,9	10	13,04	16,18	21,40	53,43	A	MCR102-050-0050-5000D100-HP803	31154201
6,00	0,5	3	35	10	75	6,9	5,9	12	15,44	19,18	25,40	38,01	B	MCR102-060-0050-3500D075-HP803	31154204
6,00	0,5	3	40	10	100	6,9	5,9	12	15,44	19,18	25,40	42,74	C	MCR102-060-0050-4000D100-HP803	31154207
6,00	0,5	3	50	12	100	6,9	5,9	12	15,44	19,18	25,40	53,01	B	MCR102-060-0050-5000D100-HP803	31154209
6,00	0,5	3	60	12	120	6,9	5,9	12	15,44	19,18	25,40	62,51	C	MCR102-060-0050-6000D120-HP803	31154211
6,00	1	3	35	10	75	6,9	5,9	12	15,34	18,93	24,90	37,96	B	MCR102-060-0100-3500D075-HP803	31154214
6,00	1	3	40	10	100	6,9	5,9	12	15,34	18,93	24,90	42,74	C	MCR102-060-0100-4000D100-HP803	31154217
6,00	1	3	50	12	100	6,9	5,9	12	15,34	18,93	24,90	52,96	B	MCR102-060-0100-5000D100-HP803	31154219
6,00	1	3	60	12	120	6,9	5,9	12	15,34	18,93	24,90	62,51	C	MCR102-060-0100-6000D120-HP803	31154221
8,00	0,5	3	50	12	100	9,2	7,8	16	21,39	26,60	35,30	51,50	C	MCR102-080-0050-5000D100-HP803	31154223
8,00	0,5	3	70	16	125	9,2	7,8	16	21,39	26,60	35,30	73,45	B	MCR102-080-0050-7000D125-HP803	31154225
8,00	0,5	3	90	16	140	9,2	7,8	16	21,39	26,60	35,30	91,04	C	MCR102-080-0050-9000D140-HP803	31154227
8,00	1	3	50	12	100	9,2	7,8	16	21,29	26,36	34,81	51,50	C	MCR102-080-0100-5000D100-HP803	31154229
8,00	1	3	70	16	125	9,2	7,8	16	21,29	26,36	34,81	73,41	B	MCR102-080-0100-7000D125-HP803	31154231
8,00	1	3	90	16	140	9,2	7,8	16	21,29	26,36	34,81	91,04	C	MCR102-080-0100-9000D140-HP803	31154233
10,00	1	3	50	16	110	11,5	9,8	20	26,09	32,35	42,80	56,85	A	MCR102-100-0100-5000D110-HP803	31154235
10,00	1	3	70	16	125	11,5	9,8	20	26,09	32,35	42,80	72,26	C	MCR102-100-0100-7000D125-HP803	31154237
10,00	2	3	50	16	110	11,5	9,8	20	25,89	31,86	41,82	56,53	A	MCR102-100-0200-5000D110-HP803	31154240
10,00	2	3	70	16	125	11,5	9,8	20	25,89	31,86	41,82	72,26	C	MCR102-100-0200-7000D125-HP803	31154242
12,00	1	3	50	16	105	13,8	11,8	24	30,89	38,35	50,11	53,47	C	MCR102-120-0100-5000D105-HP803	31154245
12,00	2	3	50	16	105	13,8	11,8	24	30,69	37,86	49,81	53,47	C	MCR102-120-0200-5000D105-HP803	31154249

Dimensions in mm.

For cutting data recommendations, see end of chapter.

Special designs and other coatings available upon request.

OptiMill®-3D-CR

Corner radius milling cutter, z=4
MCR103

Design:

Diameter of milling cutter: 6.00 - 12.00 mm
Cutting material: HP803
Number of cutting edges: 4
Helix angle: 30°
Radial contour tolerance: ±0.005 if d₁ ≤ 6 mm
±0.01 if d₁ > 6 mm

Application:

Suitable for machining workpiece materials up to 55 HRC.

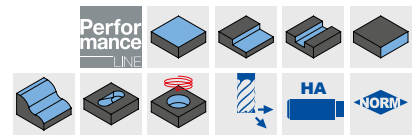
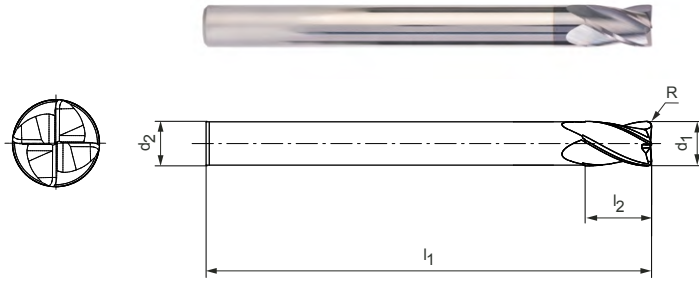

Preferred series in stock

Dimensions					z	Specification	Order no.
d ₁	R	d ₂ h5	l ₁	l ₂			
6,00	0,2	6	60	6,9	4	MCR103-060-0020-X060-HP803	31154252
6,00	0,2	6	100	6,9	4	MCR103-060-0020-X100-HP803	31154253
6,00	0,3	6	60	6,9	4	MCR103-060-0030-X060-HP803	31154254
6,00	0,3	6	100	6,9	4	MCR103-060-0030-X100-HP803	31154255
6,00	0,5	6	75	6,9	4	MCR103-060-0050-X075-HP803	31154256
6,00	0,5	6	100	6,9	4	MCR103-060-0050-X100-HP803	31154257
6,00	1	6	75	6,9	4	MCR103-060-0100-X075-HP803	31154258
6,00	1	6	100	6,9	4	MCR103-060-0100-X100-HP803	31154259
8,00	0,5	8	64	9,2	4	MCR103-080-0050-X064-HP803	31154260
8,00	0,5	8	100	9,2	4	MCR103-080-0050-X100-HP803	31154261
8,00	1	8	64	9,2	4	MCR103-080-0100-X064-HP803	31154262
8,00	1	8	100	9,2	4	MCR103-080-0100-X100-HP803	31154263
8,00	2	8	64	9,2	4	MCR103-080-0200-X064-HP803	31154264
8,00	2	8	100	9,2	4	MCR103-080-0200-X100-HP803	31154265
10,00	0,5	10	75	11,5	4	MCR103-100-0050-X075-HP803	31154266
10,00	0,5	10	120	11,5	4	MCR103-100-0050-X120-HP803	31154267
10,00	1	10	75	11,5	4	MCR103-100-0100-X075-HP803	31154268
10,00	1	10	120	11,5	4	MCR103-100-0100-X120-HP803	31154269
10,00	2	10	75	11,5	4	MCR103-100-0200-X075-HP803	31154270
10,00	2	10	120	11,5	4	MCR103-100-0200-X120-HP803	31154271
12,00	0,5	12	75	13,8	4	MCR103-120-0050-X075-HP803	31154272
12,00	0,5	12	120	13,8	4	MCR103-120-0050-X120-HP803	31154273
12,00	1	12	75	13,8	4	MCR103-120-0100-X075-HP803	31154274
12,00	1	12	120	13,8	4	MCR103-120-0100-X120-HP803	31154275
12,00	2	12	75	13,8	4	MCR103-120-0200-X075-HP803	31154276
12,00	2	12	120	13,8	4	MCR103-120-0200-X120-HP803	31154277

Dimensions in mm.

For cutting data recommendations, see end of chapter.

Special designs and other coatings available upon request.

OptiMill®-3D-CR

Corner radius milling cutter, design with neck, z=4
MCR104

Design:

Diameter of milling cutter: 3.00 - 12.00 mm
Cutting material: HP803
Number of cutting edges: 4
Helix angle: 30°
Radial contour tolerance: ±0.005 if $d_1 \leq 6$ mm
±0.01 if $d_1 > 6$ mm

Application:

Suitable for machining workpiece materials up to 55 HRC.

Shank transition:

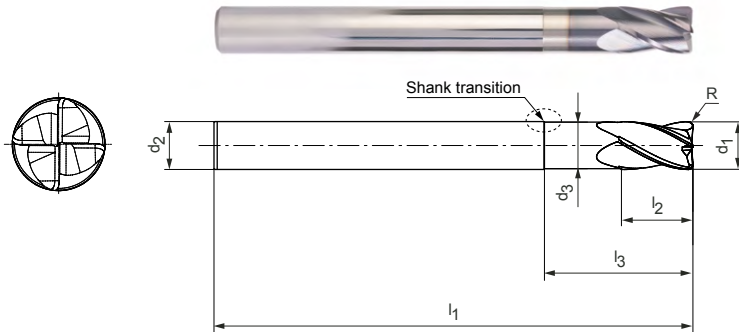
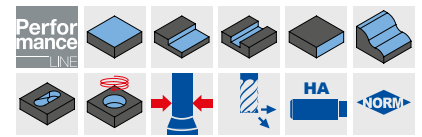
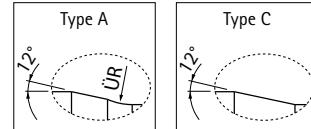

Preferred series in stock

Dimensions						Working depth at x° incline				Type	Specification	Order no.	
d ₁	R	l ₃	d ₂ h5	l ₁	l ₂	d ₃	0.5°	1°	1.5°				3°
3,00	0,2	10	6	60	3,5	2,94	11,22	11,64	11,99	13,40	A	MCR104-030-0020-1000X060-HP803	31154278
3,00	0,2	15	6	60	3,5	2,94	16,42	16,94	17,35	20,03	A	MCR104-030-0020-1500X060-HP803	31154279
3,00	0,2	20	6	60	3,5	2,94	21,60	22,19	22,94	26,67	A	MCR104-030-0020-2000X060-HP803	31154280
3,00	0,2	25	6	75	3,5	2,94	26,75	27,41	28,65	32,20	A	MCR104-030-0020-2500X075-HP803	31154281
3,00	0,5	10	6	60	3,5	2,94	11,21	11,63	11,96	13,30	A	MCR104-030-0050-1000X060-HP803	31154282
3,00	0,5	15	6	60	3,5	2,94	16,41	16,92	17,33	19,94	A	MCR104-030-0050-1500X060-HP803	31154283
3,00	0,5	20	6	60	3,5	2,94	21,59	22,18	22,90	26,57	A	MCR104-030-0050-2000X060-HP803	31154284
3,00	0,5	25	6	75	3,5	2,94	26,74	27,40	28,60	32,20	A	MCR104-030-0050-2500X075-HP803	31154285
4,00	0,2	10	6	60	4,6	3,94	11,22	11,64	11,99	13,40	A	MCR104-040-0020-1000X060-HP803	31154286
4,00	0,2	15	6	60	4,6	3,94	16,42	16,94	17,35	19,85	A	MCR104-040-0020-1500X060-HP803	31154287
4,00	0,2	20	6	60	4,6	3,94	21,60	22,19	22,94	24,85	A	MCR104-040-0020-2000X060-HP803	31154288
4,00	0,2	25	6	75	4,6	3,94	26,75	27,41	28,65	29,85	A	MCR104-040-0020-2500X075-HP803	31154289
4,00	0,2	30	6	75	4,6	3,94	31,89	32,82	34,35	34,85	A	MCR104-040-0020-3000X075-HP803	31154290
4,00	0,5	10	6	60	4,6	3,94	11,21	11,63	11,96	13,30	A	MCR104-040-0050-1000X060-HP803	31154291
4,00	0,5	15	6	60	4,6	3,94	16,41	16,92	17,33	19,85	A	MCR104-040-0050-1500X060-HP803	31154292
4,00	0,5	20	6	60	4,6	3,94	21,59	22,18	22,90	24,85	A	MCR104-040-0050-2000X060-HP803	31154293
4,00	0,5	25	6	75	4,6	3,94	26,74	27,40	28,60	29,85	A	MCR104-040-0050-2500X075-HP803	31154294
4,00	0,5	30	6	75	4,6	3,94	31,89	32,79	34,31	34,85	A	MCR104-040-0050-3000X075-HP803	31154295
5,00	0,2	15	6	60	5,8	4,9	15,88	16,58	17,35	17,59	C	MCR104-050-0020-1500X060-HP803	31154296
5,00	0,2	20	6	60	5,8	4,9	21,09	22,03	22,59	-	C	MCR104-050-0020-2000X060-HP803	31154297
5,00	0,2	25	6	60	5,8	4,9	26,31	27,48	27,59	-	C	MCR104-050-0020-2500X060-HP803	31154298
5,00	0,2	30	6	75	5,8	4,9	31,52	32,59	-	-	C	MCR104-050-0020-3000X075-HP803	31154299
5,00	0,5	15	6	60	5,8	4,9	15,87	16,55	17,31	17,59	C	MCR104-050-0050-1500X060-HP803	31154300
5,00	0,5	20	6	60	5,8	4,9	21,08	22,00	22,59	-	C	MCR104-050-0050-2000X060-HP803	31154301
5,00	0,5	25	6	60	5,8	4,9	26,29	27,45	27,59	-	C	MCR104-050-0050-2500X060-HP803	31154302
5,00	0,5	30	6	75	5,8	4,9	31,51	32,59	-	-	C	MCR104-050-0050-3000X075-HP803	31154303
6,00	0,2	15	6	60	6,9	5,9	-	-	-	-	-	MCR104-060-0020-1500X060-HP803	31154304
6,00	0,2	20	6	60	6,9	5,9	-	-	-	-	-	MCR104-060-0020-2000X060-HP803	31154305
6,00	0,2	25	6	60	6,9	5,9	-	-	-	-	-	MCR104-060-0020-2500X060-HP803	31154306
6,00	0,2	30	6	75	6,9	5,9	-	-	-	-	-	MCR104-060-0020-3000X075-HP803	31154307
6,00	0,2	35	6	75	6,9	5,9	-	-	-	-	-	MCR104-060-0020-3500X075-HP803	31154308
6,00	0,3	15	6	60	6,9	5,9	-	-	-	-	-	MCR104-060-0030-1500X060-HP803	31154309
6,00	0,3	20	6	60	6,9	5,9	-	-	-	-	-	MCR104-060-0030-2000X060-HP803	31154310
6,00	0,3	25	6	60	6,9	5,9	-	-	-	-	-	MCR104-060-0030-2500X060-HP803	31154311
6,00	0,3	30	6	75	6,9	5,9	-	-	-	-	-	MCR104-060-0030-3000X075-HP803	31154312

OptiMill®-3D-CR | MCR104 | Corner radius milling cutter, design with neck, z=4

Dimensions							Working depth at x° incline				Type	Specification	Order no.
d ₁	R	l ₃	d ₂ h5	l ₁	l ₂	d ₃	0.5°	1°	1.5°	3°			
6,00	0,3	35	6	75	6,9	5,9	-	-	-	-	-	MCR104-060-0030-3500X075-HP803	31154313
6,00	0,5	15	6	60	6,9	5,9	-	-	-	-	-	MCR104-060-0050-1500X060-HP803	31154314
6,00	0,5	20	6	60	6,9	5,9	-	-	-	-	-	MCR104-060-0050-2000X060-HP803	31154315
6,00	0,5	25	6	60	6,9	5,9	-	-	-	-	-	MCR104-060-0050-2500X060-HP803	31154316
6,00	0,5	30	6	75	6,9	5,9	-	-	-	-	-	MCR104-060-0050-3000X075-HP803	31154317
6,00	0,5	35	6	75	6,9	5,9	-	-	-	-	-	MCR104-060-0050-3500X075-HP803	31154318
6,00	1	15	6	60	6,9	5,9	-	-	-	-	-	MCR104-060-0100-1500X060-HP803	31154319
6,00	1	20	6	60	6,9	5,9	-	-	-	-	-	MCR104-060-0100-2000X060-HP803	31154320
6,00	1	25	6	60	6,9	5,9	-	-	-	-	-	MCR104-060-0100-2500X060-HP803	31154321
6,00	1	30	6	75	6,9	5,9	-	-	-	-	-	MCR104-060-0100-3000X075-HP803	31154322
6,00	1	35	6	75	6,9	5,9	-	-	-	-	-	MCR104-060-0100-3500X075-HP803	31154323
8,00	0,5	25	8	64	9,2	7,8	-	-	-	-	-	MCR104-080-0050-2500X064-HP803	31154324
8,00	0,5	50	8	100	9,2	7,8	-	-	-	-	-	MCR104-080-0050-5000X100-HP803	31154325
8,00	1	25	8	64	9,2	7,8	-	-	-	-	-	MCR104-080-0100-2500X064-HP803	31154326
8,00	1	50	8	100	9,2	7,8	-	-	-	-	-	MCR104-080-0100-5000X100-HP803	31154327
8,00	2	25	8	64	9,2	7,8	-	-	-	-	-	MCR104-080-0200-2500X064-HP803	31154328
8,00	2	50	8	100	9,2	7,8	-	-	-	-	-	MCR104-080-0200-5000X100-HP803	31154329
10,00	0,5	30	10	75	11,5	9,8	-	-	-	-	-	MCR104-100-0050-3000X075-HP803	31154330
10,00	0,5	50	10	100	11,5	9,8	-	-	-	-	-	MCR104-100-0050-5000X100-HP803	31154331
10,00	1	30	10	75	11,5	9,8	-	-	-	-	-	MCR104-100-0100-3000X075-HP803	31154332
10,00	1	50	10	100	11,5	9,8	-	-	-	-	-	MCR104-100-0100-5000X100-HP803	31154333
10,00	2	30	10	75	11,5	9,8	-	-	-	-	-	MCR104-100-0200-3000X075-HP803	31154334
10,00	2	50	10	100	11,5	9,8	-	-	-	-	-	MCR104-100-0200-5000X100-HP803	31154335
12,00	0,5	35	12	75	13,8	11,8	-	-	-	-	-	MCR104-120-0050-3500X075-HP803	31154336
12,00	0,5	60	12	100	13,8	11,8	-	-	-	-	-	MCR104-120-0050-6000X100-HP803	31154337
12,00	1	35	12	75	13,8	11,8	-	-	-	-	-	MCR104-120-0100-3500X075-HP803	31154338
12,00	1	60	12	100	13,8	11,8	-	-	-	-	-	MCR104-120-0100-6000X100-HP803	31154339
12,00	2	35	12	75	13,8	11,8	-	-	-	-	-	MCR104-120-0200-3500X075-HP803	31154340
12,00	2	60	12	100	13,8	11,8	-	-	-	-	-	MCR104-120-0200-6000X100-HP803	31154341

Dimensions in mm.

For cutting data recommendations, see end of chapter.

Special designs and other coatings available upon request.

OptiMill®-3D-CR

Corner radius milling cutter, conical design, z=4
MCR105

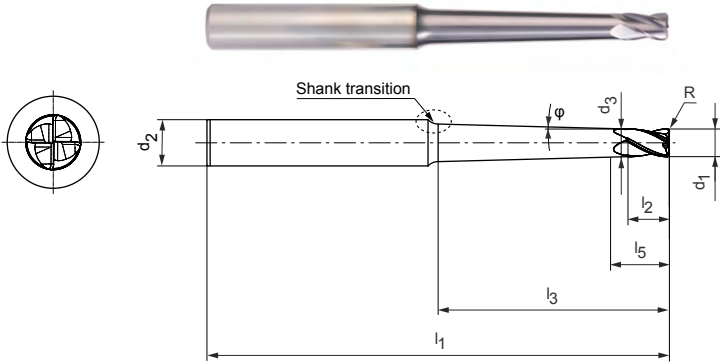

Design:

Diameter of milling cutter: 3.00 - 12.00 mm
Cutting material: HP803
Number of cutting edges: 4
Helix angle: 30°
Radial contour tolerance: ±0.005 if d₁ ≤ 6 mm
±0.01 if d₁ > 6 mm

Application:

Suitable for machining workpiece materials up to 55 HRC.

Shank transition:

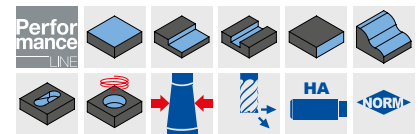
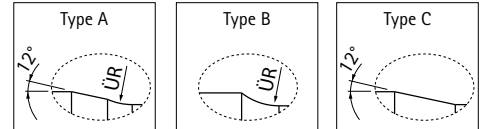

Preferred series in stock

Dimensions									Working depth at x° incline				Type	Specification	Order no.
d ₁	R	φ [°]	l ₃	d ₂ h5	l ₁	l ₂	d ₃	l ₅	0.5°	1°	1.5°	3°			
3,00	0,3	0,5	20	6	60	3,5	2,94	6	21,03	21,82	22,36	25,87	A	MCR105-030-0030-2000A060-HP803	31154342
3,00	0,3	0,5	25	6	75	3,5	2,94	6	26,03	26,96	27,74	31,42	A	MCR105-030-0030-2500A075-HP803	31154343
3,00	0,3	0,5	30	6	75	3,5	2,94	6	31,03	32,09	33,21	36,21	A	MCR105-030-0030-3000A075-HP803	31154344
3,00	0,3	0,5	35	6	75	3,5	2,94	6	36,03	37,21	38,68	41,01	A	MCR105-030-0030-3500A075-HP803	31154345
3,00	0,3	0,5	40	6	100	3,5	2,94	6	41,03	42,32	44,15	45,80	A	MCR105-030-0030-4000A100-HP803	31154346
3,00	0,3	1	15	6	60	3,5	2,94	6	15,18	16,35	16,90	19,02	A	MCR105-030-0030-1500B060-HP803	31154348
3,00	0,3	1	20	6	60	3,5	2,94	6	15,14	21,35	22,03	25,11	A	MCR105-030-0030-2000B060-HP803	31154354
3,00	0,3	1	25	6	75	3,5	2,94	6	15,14	26,35	27,16	30,64	A	MCR105-030-0030-2500B075-HP803	31154355
3,00	0,3	1	30	6	75	3,5	2,94	6	15,14	31,35	32,28	35,23	A	MCR105-030-0030-3000B075-HP803	31154356
3,00	0,3	1	35	6	75	3,5	2,94	6	15,14	36,35	37,39	39,82	A	MCR105-030-0030-3500B075-HP803	31154357
3,00	0,3	1	40	6	100	3,5	2,94	6	15,14	41,35	42,56	44,41	A	MCR105-030-0030-4000B100-HP803	31154358
3,00	0,3	1,5	15	6	60	3,5	2,94	6	10,57	15,89	16,62	18,53	A	MCR105-030-0030-1500C060-HP803	31154365
3,00	0,3	1,5	20	6	60	3,5	2,94	6	10,57	20,42	21,62	24,35	A	MCR105-030-0030-2000C060-HP803	31154366
3,00	0,3	1,5	25	6	75	3,5	2,94	6	10,57	20,84	26,62	29,86	A	MCR105-030-0030-2500C075-HP803	31154367
3,00	0,3	1,5	30	6	75	3,5	2,94	6	10,57	20,84	31,62	34,24	A	MCR105-030-0030-3000C075-HP803	31154368
3,00	0,3	1,5	35	6	75	3,5	2,94	6	10,57	20,84	36,62	37,94	B	MCR105-030-0030-3500C075-HP803	31154369
3,00	0,3	1,5	40	6	75	3,5	2,94	6	10,57	20,84	40,96	43,01	C	MCR105-030-0030-4000C075-HP803	31154370
3,00	0,5	0,5	15	6	60	3,5	2,94	6	16,02	16,66	17,12	19,45	A	MCR105-030-0050-1500A060-HP803	31154347
3,00	0,5	0,5	20	6	60	3,5	2,94	6	21,02	21,81	22,35	25,81	A	MCR105-030-0050-2000A060-HP803	31154349
3,00	0,5	0,5	25	6	75	3,5	2,94	6	26,02	26,95	27,71	31,42	A	MCR105-030-0050-2500A075-HP803	31154350
3,00	0,5	0,5	30	6	75	3,5	2,94	6	31,02	32,08	33,18	36,21	A	MCR105-030-0050-3000A075-HP803	31154351
3,00	0,5	0,5	35	6	75	3,5	2,94	6	36,02	37,20	38,65	41,01	A	MCR105-030-0050-3500A075-HP803	31154352
3,00	0,5	0,5	40	6	100	3,5	2,94	6	41,02	42,31	44,12	45,80	A	MCR105-030-0050-4000A100-HP803	31154353
3,00	0,5	1	15	6	60	3,5	2,94	6	14,94	16,33	16,88	18,96	A	MCR105-030-0050-1500B060-HP803	31154359
3,00	0,5	1	20	6	60	3,5	2,94	6	14,94	21,33	22,02	25,05	A	MCR105-030-0050-2000B060-HP803	31154360
3,00	0,5	1	25	6	75	3,5	2,94	6	14,94	26,33	27,14	30,64	A	MCR105-030-0050-2500B075-HP803	31154361
3,00	0,5	1	30	6	75	3,5	2,94	6	14,94	31,33	32,26	35,23	A	MCR105-030-0050-3000B075-HP803	31154362
3,00	0,5	1	35	6	75	3,5	2,94	6	14,94	36,33	37,37	39,82	A	MCR105-030-0050-3500B075-HP803	31154363
3,00	0,5	1	40	6	100	3,5	2,94	6	14,94	41,33	42,53	44,41	A	MCR105-030-0050-4000B100-HP803	31154364
3,00	0,5	1,5	15	6	60	3,5	2,94	6	10,47	15,86	16,60	18,47	A	MCR105-030-0050-1500C060-HP803	31154371
3,00	0,5	1,5	20	6	60	3,5	2,94	6	10,47	20,34	21,60	24,28	A	MCR105-030-0050-2000C060-HP803	31154372
3,00	0,5	1,5	25	6	75	3,5	2,94	6	10,47	20,44	26,60	29,86	A	MCR105-030-0050-2500C075-HP803	31154373
3,00	0,5	1,5	30	6	75	3,5	2,94	6	10,47	20,44	31,60	34,24	A	MCR105-030-0050-3000C075-HP803	31154374
3,00	0,5	1,5	35	6	75	3,5	2,94	6	10,47	20,44	36,60	37,94	B	MCR105-030-0050-3500C075-HP803	31154375
3,00	0,5	1,5	40	6	75	3,5	2,94	6	10,47	20,44	40,93	43,01	C	MCR105-030-0050-4000C075-HP803	31154376

OptiMill®-3D-CR | MCR105 | Corner radius milling cutter, conical design with working depth, z=4

Dimensions									Working depth at x° incline				Type	Specification	Order no.
d ₁	R	φ [°]	l ₃	d ₂ h5	l ₁	l ₂	d ₃	l ₅	0.5°	1°	1.5°	3°			
4,00	0,3	0,5	20	6	60	4,6	3,94	8	21,13	21,88	22,41	24,35	A	MCR105-040-0030-2000A060-HP803	31154387
4,00	0,3	0,5	25	6	75	4,6	3,94	8	26,13	27,01	27,84	29,15	A	MCR105-040-0030-2500A075-HP803	31154390
4,00	0,3	0,5	30	6	75	4,6	3,94	8	31,13	32,14	33,30	33,94	A	MCR105-040-0030-3000A075-HP803	31154394
4,00	0,3	0,5	35	6	75	4,6	3,94	8	36,13	37,25	37,96	37,98	B	MCR105-040-0030-3500A075-HP803	31154398
4,00	0,3	0,5	40	6	75	4,6	3,94	8	41,13	42,36	42,91	-	B	MCR105-040-0030-4000A075-HP803	31154402
4,00	0,3	0,5	45	6	100	4,6	3,94	8	46,13	47,47	47,83	-	B	MCR105-040-0030-4500A100-HP803	31154406
4,00	0,3	0,5	50	6	100	4,6	3,94	8	50,48	52,72	53,12	-	C	MCR105-040-0030-5000A100-HP803	31154410
4,00	0,3	1	20	6	60	4,6	3,94	8	19,14	21,50	22,13	23,86	A	MCR105-040-0030-2000B060-HP803	31154388
4,00	0,3	1	25	6	60	4,6	3,94	8	19,14	26,50	27,25	27,87	B	MCR105-040-0030-2500B060-HP803	31154391
4,00	0,3	1	30	6	75	4,6	3,94	8	19,14	30,84	32,27	33,04	C	MCR105-040-0030-3000B075-HP803	31154395
4,00	0,3	1	35	6	75	4,6	3,94	8	19,14	35,84	37,51	37,63	C	MCR105-040-0030-3500B075-HP803	31154399
4,00	0,3	1	40	8	100	4,6	3,94	8	19,14	41,50	42,74	46,92	A	MCR105-040-0030-4000B100-HP803	31154403
4,00	0,3	1	45	8	100	4,6	3,94	8	19,14	46,50	47,98	51,51	A	MCR105-040-0030-4500B100-HP803	31154407
4,00	0,3	1	50	8	100	4,6	3,94	8	19,14	51,50	53,21	56,10	A	MCR105-040-0030-5000B100-HP803	31154411
4,00	0,3	1,5	20	6	60	4,6	3,94	8	13,57	20,95	21,81	22,84	B	MCR105-040-0030-2000C060-HP803	31154389
4,00	0,3	1,5	25	6	60	4,6	3,94	8	13,57	25,08	26,24	27,75	C	MCR105-040-0030-2500C060-HP803	31154392
4,00	0,3	1,5	30	8	75	4,6	3,94	8	13,57	26,84	31,81	36,31	A	MCR105-040-0030-3000C075-HP803	31154396
4,00	0,3	1,5	35	8	75	4,6	3,94	8	13,57	26,84	36,81	41,22	A	MCR105-040-0030-3500C075-HP803	31154400
4,00	0,3	1,5	40	8	100	4,6	3,94	8	13,57	26,84	41,81	45,61	A	MCR105-040-0030-4000C100-HP803	31154404
4,00	0,3	1,5	45	8	100	4,6	3,94	8	13,57	26,84	46,81	49,99	A	MCR105-040-0030-4500C100-HP803	31154408
4,00	0,3	1,5	50	8	100	4,6	3,94	8	13,57	26,84	51,81	54,38	A	MCR105-040-0030-5000C100-HP803	31154412
4,00	0,5	0,5	20	6	60	4,6	3,94	8	21,12	21,87	22,40	24,35	A	MCR105-040-0050-2000A060-HP803	31154414
4,00	0,5	0,5	25	6	75	4,6	3,94	8	26,12	27,00	27,81	29,15	A	MCR105-040-0050-2500A075-HP803	31154417
4,00	0,5	0,5	30	6	75	4,6	3,94	8	31,12	32,13	33,28	33,94	A	MCR105-040-0050-3000A075-HP803	31154421
4,00	0,5	0,5	35	6	75	4,6	3,94	8	36,12	37,25	37,95	37,98	B	MCR105-040-0050-3500A075-HP803	31154425
4,00	0,5	0,5	40	6	75	4,6	3,94	8	41,12	42,35	42,91	-	B	MCR105-040-0050-4000A075-HP803	31154429
4,00	0,5	0,5	45	6	100	4,6	3,94	8	46,12	47,46	47,83	-	B	MCR105-040-0050-4500A100-HP803	31154433
4,00	0,5	0,5	50	6	100	4,6	3,94	8	50,47	52,70	53,12	-	C	MCR105-040-0050-5000A100-HP803	31154437
4,00	0,5	1	20	6	60	4,6	3,94	8	18,94	21,49	22,12	23,86	A	MCR105-040-0050-2000B060-HP803	31154415
4,00	0,5	1	25	6	60	4,6	3,94	8	18,94	26,49	27,24	27,87	B	MCR105-040-0050-2500B060-HP803	31154418
4,00	0,5	1	30	6	75	4,6	3,94	8	18,94	30,83	32,25	33,04	C	MCR105-040-0050-3000B075-HP803	31154422
4,00	0,5	1	35	6	75	4,6	3,94	8	18,94	35,83	37,48	37,63	C	MCR105-040-0050-3500B075-HP803	31154426
4,00	0,5	1	40	8	100	4,6	3,94	8	18,94	41,49	42,71	46,92	A	MCR105-040-0050-4000B100-HP803	31154430
4,00	0,5	1	45	8	100	4,6	3,94	8	18,94	46,49	47,95	51,51	A	MCR105-040-0050-4500B100-HP803	31154434
4,00	0,5	1	50	8	100	4,6	3,94	8	18,94	51,49	53,18	56,10	A	MCR105-040-0050-5000B100-HP803	31154438
4,00	0,5	1,5	20	6	60	4,6	3,94	8	13,47	20,93	21,79	22,84	B	MCR105-040-0050-2000C060-HP803	31154416
4,00	0,5	1,5	25	6	60	4,6	3,94	8	13,47	25,06	26,22	27,75	C	MCR105-040-0050-2500C060-HP803	31154419
4,00	0,5	1,5	30	8	75	4,6	3,94	8	13,47	26,44	31,79	36,25	A	MCR105-040-0050-3000C075-HP803	31154423
4,00	0,5	1,5	35	8	75	4,6	3,94	8	13,47	26,44	36,79	41,22	A	MCR105-040-0050-3500C075-HP803	31154427
4,00	0,5	1,5	40	8	100	4,6	3,94	8	13,47	26,44	41,79	45,61	A	MCR105-040-0050-4000C100-HP803	31154431
4,00	0,5	1,5	45	8	100	4,6	3,94	8	13,47	26,44	46,79	49,99	A	MCR105-040-0050-4500C100-HP803	31154435
4,00	0,5	1,5	50	8	100	4,6	3,94	8	13,47	26,44	51,79	54,38	A	MCR105-040-0050-5000C100-HP803	31154439
5,00	0,5	1	30	8	75	5,8	4,9	10	25,23	31,70	32,54	35,65	A	MCR105-050-0050-3000B075-HP803	31154441
5,00	0,5	1	50	8	100	5,8	4,9	10	25,23	51,70	52,86	53,08	B	MCR105-050-0050-5000B100-HP803	31154444
5,00	0,5	1,5	30	8	75	5,8	4,9	10	17,61	30,81	32,02	34,83	A	MCR105-050-0050-3000C075-HP803	31154442
6,00	0,5	1	35	8	75	6,9	5,9	12	29,23	36,29	37,96	38,05	C	MCR105-060-0050-3500B075-HP803	31154446
6,00	0,5	1	40	8	75	6,9	5,9	12	29,23	41,29	42,64	-	C	MCR105-060-0050-4000B075-HP803	31154449
6,00	0,5	1	50	10	100	6,9	5,9	12	29,23	51,82	53,67	56,52	A	MCR105-060-0050-5000B100-HP803	31154452
6,00	0,5	1	60	10	110	6,9	5,9	12	29,23	61,82	64,13	65,70	A	MCR105-060-0050-6000B110-HP803	31154454
6,00	0,5	1,5	35	10	100	6,9	5,9	12	20,61	35,88	37,18	41,81	A	MCR105-060-0050-3500C100-HP803	31154447
6,00	0,5	1,5	40	10	100	6,9	5,9	12	20,61	40,40	42,18	46,20	A	MCR105-060-0050-4000C100-HP803	31154450
6,00	1	1	35	8	75	6,9	5,9	12	28,73	36,24	37,89	38,05	C	MCR105-060-0100-3500B075-HP803	31154456
6,00	1	1	40	8	75	6,9	5,9	12	28,73	41,24	42,64	-	C	MCR105-060-0100-4000B075-HP803	31154459
6,00	1	1	50	10	100	6,9	5,9	12	28,73	51,79	53,60	56,52	A	MCR105-060-0100-5000B100-HP803	31154462
6,00	1	1	60	10	110	6,9	5,9	12	28,73	61,79	64,06	65,70	A	MCR105-060-0100-6000B110-HP803	31154464
6,00	1	1,5	35	10	100	6,9	5,9	12	20,36	35,81	37,14	41,81	A	MCR105-060-0100-3500C100-HP803	31154457
6,00	1	1,5	40	10	100	6,9	5,9	12	20,36	39,74	42,14	46,20	A	MCR105-060-0100-4000C100-HP803	31154460

OptiMill®-3D-CR | MCR105 | Corner radius milling cutter, conical design with working depth, z=4

Dimensions									Working depth at x° incline				Type	Specification	Order no.
d ₁	R	φ [°]	l ₃	d ₂ h5	l ₁	l ₂	d ₃	l ₅	0.5°	1°	1.5°	3°			
8,00	0,5	1	50	12	100	9,2	7,8	16	42,96	52,18	54,31	57,09	A	MCR105-080-0050-5000B100-HP803	31154466
8,00	0,5	1	70	12	120	9,2	7,8	16	42,96	72,18	75,25	75,45	A	MCR105-080-0050-7000B120-HP803	31154468
8,00	0,5	1	90	12	140	9,2	7,8	16	42,96	91,90	93,80	-	C	MCR105-080-0050-9000B140-HP803	31154470
8,00	1	1	50	12	100	9,2	7,8	16	42,46	52,15	54,24	57,09	A	MCR105-080-0100-5000B100-HP803	31154472
8,00	1	1	70	12	120	9,2	7,8	16	42,46	72,15	75,18	75,45	A	MCR105-080-0100-7000B120-HP803	31154474
8,00	1	1	90	12	140	9,2	7,8	16	42,46	91,86	93,80	-	C	MCR105-080-0100-9000B140-HP803	31154476
10,00	1	1	50	16	115	11,5	9,8	20	50,28	52,33	54,61	62,12	A	MCR105-100-0100-5000B115-HP803	31154478
10,00	1	1	70	16	130	11,5	9,8	20	50,46	72,33	75,55	80,48	A	MCR105-100-0100-7000B130-HP803	31154480
10,00	1	1	90	16	150	11,5	9,8	20	50,46	92,33	96,49	98,84	A	MCR105-100-0100-9000B150-HP803	31154482
10,00	2	1	50	16	115	11,5	9,8	20	49,46	52,29	54,47	62,12	A	MCR105-100-0200-5000B115-HP803	31154483
10,00	2	1	70	16	130	11,5	9,8	20	49,46	72,29	75,41	80,48	A	MCR105-100-0200-7000B130-HP803	31154485
10,00	2	1	90	16	150	11,5	9,8	20	49,46	92,29	96,35	98,84	A	MCR105-100-0200-9000B150-HP803	31154487
12,00	1	1	50	16	110	13,8	11,8	24	50,99	52,57	54,99	57,74	A	MCR105-120-0100-5000B110-HP803	31154488
12,00	1	1	70	16	125	13,8	11,8	24	58,46	72,50	73,60	73,73	B	MCR105-120-0100-7000B125-HP803	31154490
12,00	1	1	90	16	145	13,8	11,8	24	58,46	92,50	93,24	-	B	MCR105-120-0100-9000B145-HP803	31154491
12,00	2	1	50	16	110	13,8	11,8	24	50,94	52,48	54,85	57,74	A	MCR105-120-0200-5000B110-HP803	31154492
12,00	2	1	70	16	125	13,8	11,8	24	57,46	72,46	73,56	73,73	B	MCR105-120-0200-7000B125-HP803	31154494
12,00	2	1	90	16	145	13,8	11,8	24	57,46	92,46	93,24	-	B	MCR105-120-0200-9000B145-HP803	31154495

Available on request

3,00	0,3	3	20	6	60	3,5	2,94	6	7,83	9,71	12,84	22,28	B	MCR105-030-0030-2000D060-HP803	31154377
3,00	0,3	3	25	6	60	3,5	2,94	6	7,83	9,71	12,84	27,06	C	MCR105-030-0030-2500D060-HP803	31154378
3,00	0,3	3	30	8	75	3,5	2,94	6	7,83	9,71	12,84	32,28	A	MCR105-030-0030-3000D075-HP803	31154379
3,00	0,3	3	35	8	75	3,5	2,94	6	7,83	9,71	12,84	37,28	A	MCR105-030-0030-3500D075-HP803	31154380
3,00	0,3	3	40	8	75	3,5	2,94	6	7,83	9,71	12,84	42,28	B	MCR105-030-0030-4000D075-HP803	31154381
3,00	0,5	3	20	6	60	3,5	2,94	6	7,79	9,61	12,64	22,25	B	MCR105-030-0050-2000D060-HP803	31154382
3,00	0,5	3	25	6	60	3,5	2,94	6	7,79	9,61	12,64	26,99	C	MCR105-030-0050-2500D060-HP803	31154383
3,00	0,5	3	30	8	75	3,5	2,94	6	7,79	9,61	12,64	32,25	A	MCR105-030-0050-3000D075-HP803	31154384
3,00	0,5	3	35	8	75	3,5	2,94	6	7,79	9,61	12,64	37,25	A	MCR105-030-0050-3500D075-HP803	31154385
3,00	0,5	3	40	8	75	3,5	2,94	6	7,79	9,61	12,64	42,25	B	MCR105-030-0050-4000D075-HP803	31154386
4,00	0,3	3	25	8	64	4,6	3,94	8	10,23	12,70	16,84	27,71	A	MCR105-040-0030-2500D064-HP803	31154393
4,00	0,3	3	30	8	75	4,6	3,94	8	10,23	12,70	16,84	32,55	B	MCR105-040-0030-3000D075-HP803	31154397
4,00	0,3	3	35	8	75	4,6	3,94	8	10,23	12,70	16,84	37,71	C	MCR105-040-0030-3500D075-HP803	31154401
4,00	0,3	3	40	8	75	4,6	3,94	8	10,23	12,70	16,84	41,66	C	MCR105-040-0030-4000D075-HP803	31154405
4,00	0,3	3	45	10	100	4,6	3,94	8	10,23	12,70	16,84	47,71	A	MCR105-040-0030-4500D100-HP803	31154409
4,00	0,3	3	50	10	100	4,6	3,94	8	10,23	12,70	16,84	52,55	B	MCR105-040-0030-5000D100-HP803	31154413
4,00	0,5	3	25	8	64	4,6	3,94	8	10,19	12,61	16,64	27,65	A	MCR105-040-0050-2500D064-HP803	31154420
4,00	0,5	3	30	8	75	4,6	3,94	8	10,19	12,61	16,64	32,52	B	MCR105-040-0050-3000D075-HP803	31154424
4,00	0,5	3	35	8	75	4,6	3,94	8	10,19	12,61	16,64	37,65	C	MCR105-040-0050-3500D075-HP803	31154428
4,00	0,5	3	40	10	100	4,6	3,94	8	10,19	12,61	16,64	42,65	A	MCR105-040-0050-4000D100-HP803	31154432
4,00	0,5	3	45	10	100	4,6	3,94	8	10,19	12,61	16,64	47,65	A	MCR105-040-0050-4500D100-HP803	31154436
4,00	0,5	3	50	10	100	4,6	3,94	8	10,19	12,61	16,64	52,52	B	MCR105-040-0050-5000D100-HP803	31154440
5,00	0,5	3	30	10	75	5,8	4,9	10	13,04	16,18	21,40	33,43	A	MCR105-050-0050-3000D075-HP803	31154443
5,00	0,5	3	50	12	100	5,8	4,9	10	13,04	16,18	21,40	53,43	A	MCR105-050-0050-5000D100-HP803	31154445
6,00	0,5	3	35	10	75	6,9	5,9	12	15,44	19,18	25,40	38,01	B	MCR105-060-0050-3500D075-HP803	31154448
6,00	0,5	3	40	10	100	6,9	5,9	12	15,44	19,18	25,40	42,74	C	MCR105-060-0050-4000D100-HP803	31154451
6,00	0,5	3	50	12	100	6,9	5,9	12	15,44	19,18	25,40	53,01	B	MCR105-060-0050-5000D100-HP803	31154453
6,00	0,5	3	60	12	120	6,9	5,9	12	15,44	19,18	25,40	62,51	C	MCR105-060-0050-6000D120-HP803	31154455
6,00	1	3	35	10	75	6,9	5,9	12	15,34	18,93	24,90	37,96	B	MCR105-060-0100-3500D075-HP803	31154458
6,00	1	3	40	10	100	6,9	5,9	12	15,34	18,93	24,90	42,74	C	MCR105-060-0100-4000D100-HP803	31154461
6,00	1	3	50	12	100	6,9	5,9	12	15,34	18,93	24,90	52,96	B	MCR105-060-0100-5000D100-HP803	31154463
6,00	1	3	60	12	120	6,9	5,9	12	15,34	18,93	24,90	62,51	C	MCR105-060-0100-6000D120-HP803	31154465
8,00	0,5	3	50	12	100	9,2	7,8	16	21,39	26,60	35,30	51,50	C	MCR105-080-0050-5000D100-HP803	31154467
8,00	0,5	3	70	16	125	9,2	7,8	16	21,39	26,60	35,30	73,45	B	MCR105-080-0050-7000D125-HP803	31154469
8,00	0,5	3	90	16	140	9,2	7,8	16	21,39	26,60	35,30	91,04	C	MCR105-080-0050-9000D140-HP803	31154471
8,00	1	3	50	12	100	9,2	7,8	16	21,29	26,36	34,81	51,50	C	MCR105-080-0100-5000D100-HP803	31154473

Continued on next page.

OptiMill®-3D-CR | MCR105 | Corner radius milling cutter, conical design with working depth, z=4

Dimensions									Working depth at x° incline				Type	Specification	Order no.
d ₁	R	φ [°]	l ₃	d ₂ h5	l ₁	l ₂	d ₃	l ₅	0.5°	1°	1.5°	3°			
8,00	1	3	70	16	125	9,2	7,8	16	21,29	26,36	34,81	73,41	B	MCR105-080-0100-7000D125-HP803	31154475
8,00	1	3	90	16	140	9,2	7,8	16	21,29	26,36	34,81	91,04	C	MCR105-080-0100-9000D140-HP803	31154477
10,00	1	3	50	16	110	11,5	9,8	20	26,09	32,35	42,80	56,85	A	MCR105-100-0100-5000D110-HP803	31154479
10,00	1	3	70	16	125	11,5	9,8	20	26,09	32,35	42,80	72,26	C	MCR105-100-0100-7000D125-HP803	31154481
10,00	2	3	50	16	110	11,5	9,8	20	25,89	31,86	41,82	56,53	A	MCR105-100-0200-5000D110-HP803	31154484
10,00	2	3	70	16	125	11,5	9,8	20	25,89	31,86	41,82	72,26	C	MCR105-100-0200-7000D125-HP803	31154486
12,00	1	3	50	16	105	13,8	11,8	24	30,89	38,35	50,11	53,47	C	MCR105-120-0100-5000D105-HP803	31154489
12,00	2	3	50	16	105	13,8	11,8	24	30,69	37,86	49,81	53,47	C	MCR105-120-0200-5000D105-HP803	31154493

Dimensions in mm.

For cutting data recommendations, see end of chapter.

Special designs and other coatings available upon request.

OptiMill®-3D-CR-Hardened

Corner radius milling cutter, z=2
MCR106

Design:

Diameter of milling cutter: 6.00 - 12.00 mm
Cutting material: HP808
Number of cutting edges: 2
Helix angle: 28°
Radial contour tolerance: ± 0.005 if $d_1 \leq 6$ mm
 ± 0.01 if $d_1 > 6$ mm

Application:

Suitable for machining workpiece materials up to 68 HRC.

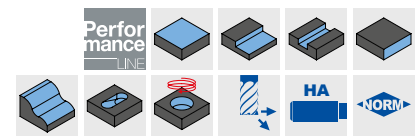
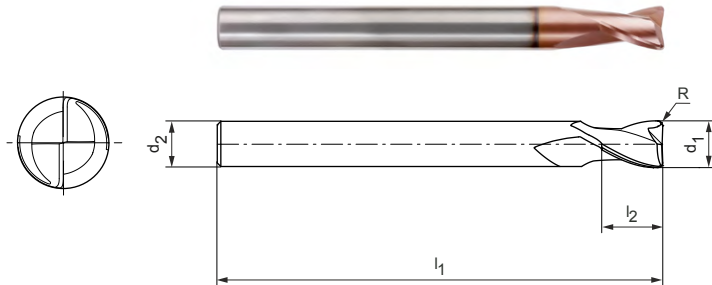

Preferred series in stock

Dimensions					z	Specification	Order no.
d ₁	R	d ₂ h5	l ₁	l ₂			
6,00	0,2	6	60	6,9	2	MCR106-060-0020-X060-HP808	31154496
6,00	0,2	6	100	6,9	2	MCR106-060-0020-X100-HP808	31154497
6,00	0,3	6	60	6,9	2	MCR106-060-0030-X060-HP808	31154498
6,00	0,3	6	100	6,9	2	MCR106-060-0030-X100-HP808	31154499
6,00	0,5	6	75	6,9	2	MCR106-060-0050-X075-HP808	31154500
6,00	0,5	6	100	6,9	2	MCR106-060-0050-X100-HP808	31154501
6,00	1	6	75	6,9	2	MCR106-060-0100-X075-HP808	31154502
6,00	1	6	100	6,9	2	MCR106-060-0100-X100-HP808	31154503
8,00	0,5	8	64	9,2	2	MCR106-080-0050-X064-HP808	31154504
8,00	0,5	8	100	9,2	2	MCR106-080-0050-X100-HP808	31154505
8,00	1	8	64	9,2	2	MCR106-080-0100-X064-HP808	31154506
8,00	1	8	100	9,2	2	MCR106-080-0100-X100-HP808	31154507
8,00	2	8	64	9,2	2	MCR106-080-0200-X064-HP808	31154508
8,00	2	8	100	9,2	2	MCR106-080-0200-X100-HP808	31154509
10,00	0,5	10	75	11,5	2	MCR106-100-0050-X075-HP808	31154510
10,00	0,5	10	120	11,5	2	MCR106-100-0050-X120-HP808	31154511
10,00	1	10	75	11,5	2	MCR106-100-0100-X075-HP808	31154512
10,00	1	10	120	11,5	2	MCR106-100-0100-X120-HP808	31154513
10,00	2	10	75	11,5	2	MCR106-100-0200-X075-HP808	31154514
10,00	2	10	120	11,5	2	MCR106-100-0200-X120-HP808	31154515
12,00	0,5	12	75	13,8	2	MCR106-120-0050-X075-HP808	31154516
12,00	0,5	12	120	13,8	2	MCR106-120-0050-X120-HP808	31154517
12,00	1	12	75	13,8	2	MCR106-120-0100-X075-HP808	31154518
12,00	1	12	120	13,8	2	MCR106-120-0100-X120-HP808	31154519
12,00	2	12	75	13,8	2	MCR106-120-0200-X075-HP808	31154520
12,00	2	12	120	13,8	2	MCR106-120-0200-X120-HP808	31154521

Dimensions in mm.

For cutting data recommendations, see end of chapter.

Special designs and other coatings available upon request.

OptiMill®-3D-CR-Hardened

Corner radius milling cutter, design with neck, z=2
MCR107

Design:

Diameter of milling cutter: 0.10 - 12.00 mm
Cutting material: HP808/HP818
Number of cutting edges: 2
Helix angle: 28°
Radial contour tolerance: ±0.005 if $d_1 \leq 6$ mm
±0.01 if $d_1 > 6$ mm

Application:

Suitable for machining workpiece materials up to 68 HRC.

Shank transition:

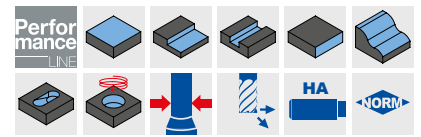
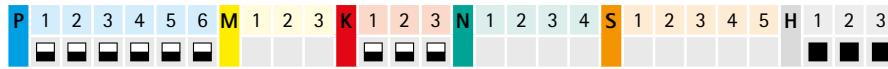
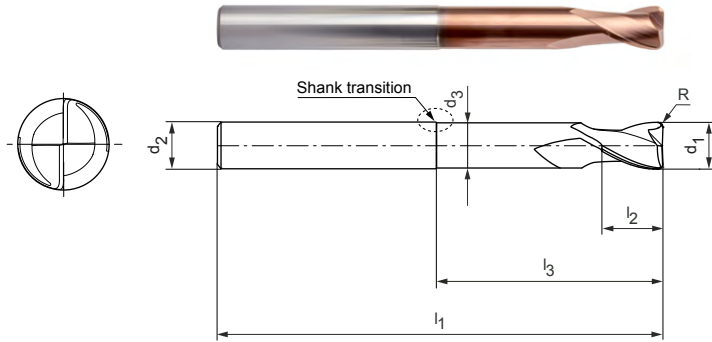
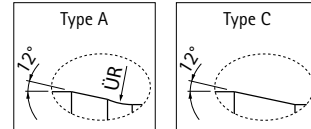

Preferred series in stock

Dimensions						Working depth at x° incline				Type	Specification	Order no.	
d ₁	R	l ₃	d ₂ h5	l ₁	l ₂	d ₃	0.5°	1°	1.5°				3°
0,10	0,02	0,3	4	50	0,1	0,075	0,56	0,60	0,64	0,75	A	MCR107-001-0002-0030X050-HP818	31154522
0,20	0,05	0,5	6	60	0,2	0,17	0,79	0,84	0,88	1,01	A	MCR107-002-0005-0050X060-HP818	31154527
0,30	0,05	0,5	4	50	0,3	0,27	0,79	0,84	0,88	1,01	A	MCR107-003-0005-0050X050-HP818	31154534
0,40	0,1	0,75	4	50	0,5	0,37	1,05	1,11	1,16	1,30	A	MCR107-004-0010-0075X050-HP818	31154542
0,40	0,1	1	4	50	0,5	0,37	1,32	1,39	1,45	1,61	A	MCR107-004-0010-0100X050-HP818	31154543
0,40	0,1	1,5	4	50	0,5	0,37	1,85	1,93	2,01	2,20	A	MCR107-004-0010-0150X050-HP818	31154544
0,40	0,1	2	4	50	0,5	0,37	2,37	2,47	2,56	2,77	A	MCR107-004-0010-0200X050-HP818	31154545
0,40	0,1	2	6	60	0,5	0,37	2,37	2,47	2,56	2,77	A	MCR107-004-0010-0200X060-HP818	31154546
0,40	0,1	3	6	60	0,5	0,37	3,42	3,54	3,65	4,04	A	MCR107-004-0010-0300X060-HP818	31154547
0,50	0,1	1,5	4	50	0,6	0,46	1,88	1,95	2,03	2,21	A	MCR107-005-0010-0150X050-HP818	31154548
0,50	0,1	2	4	50	0,6	0,46	2,40	2,49	2,58	2,79	A	MCR107-005-0010-0200X050-HP818	31154549
0,50	0,1	3	4	50	0,6	0,46	3,44	3,56	3,66	4,07	A	MCR107-005-0010-0300X050-HP818	31154550
0,50	0,1	4	4	50	0,6	0,46	4,48	4,62	4,74	5,40	A	MCR107-005-0010-0400X050-HP818	31154551
0,50	0,1	4	6	60	0,6	0,46	4,48	4,62	4,74	5,40	A	MCR107-005-0010-0400X060-HP818	31154552
0,50	0,1	5	4	50	0,6	0,46	5,51	5,67	5,81	6,73	A	MCR107-005-0010-0500X050-HP818	31154553
0,50	0,1	6	4	50	0,6	0,46	6,55	6,72	6,94	8,06	A	MCR107-005-0010-0600X050-HP818	31154554
0,50	0,1	6	6	60	0,6	0,46	6,55	6,72	6,94	8,06	A	MCR107-005-0010-0600X060-HP818	31154555
0,60	0,1	2	4	50	0,7	0,56	2,40	2,49	2,58	2,79	A	MCR107-006-0010-0200X050-HP818	31154556
0,60	0,1	3	4	50	0,7	0,56	3,44	3,56	3,66	4,07	A	MCR107-006-0010-0300X050-HP818	31154557
0,60	0,1	4	4	50	0,7	0,56	4,48	4,62	4,74	5,40	A	MCR107-006-0010-0400X050-HP818	31154558
0,60	0,1	4	6	60	0,7	0,56	4,48	4,62	4,74	5,40	A	MCR107-006-0010-0400X060-HP818	31154559
0,60	0,1	5	4	50	0,7	0,56	5,51	5,67	5,81	6,73	A	MCR107-006-0010-0500X050-HP818	31154560
0,60	0,1	6	4	50	0,7	0,56	6,55	6,72	6,94	8,06	A	MCR107-006-0010-0600X050-HP818	31154561
0,60	0,1	6	6	60	0,7	0,56	6,55	6,72	6,94	8,06	A	MCR107-006-0010-0600X060-HP818	31154562
0,60	0,1	8	6	60	0,7	0,56	8,61	8,81	9,22	10,71	A	MCR107-006-0010-0800X060-HP818	31154563
0,80	0,1	3	4	50	0,9	0,76	3,44	3,56	3,66	4,07	A	MCR107-008-0010-0300X050-HP818	31154564
0,80	0,1	4	4	50	0,9	0,76	4,48	4,62	4,74	5,40	A	MCR107-008-0010-0400X050-HP818	31154565
0,80	0,1	6	4	50	0,9	0,76	6,55	6,72	6,94	8,06	A	MCR107-008-0010-0600X050-HP818	31154566
0,80	0,1	6	6	60	0,9	0,76	6,55	6,72	6,94	8,06	A	MCR107-008-0010-0600X060-HP818	31154567
0,80	0,1	8	4	50	0,9	0,76	8,61	8,81	9,22	10,71	A	MCR107-008-0010-0800X050-HP818	31154568
0,80	0,1	8	6	60	0,9	0,76	8,61	8,81	9,22	10,71	A	MCR107-008-0010-0800X060-HP818	31154569
0,80	0,1	10	6	60	0,9	0,76	10,66	10,99	11,50	13,37	A	MCR107-008-0010-1000X060-HP818	31154570
1,00	0,2	3	4	50	1,2	0,94	3,48	3,59	3,69	4,11	A	MCR107-010-0020-0300X050-HP818	31154571
1,00	0,2	4	4	50	1,2	0,94	4,52	4,65	4,76	5,43	A	MCR107-010-0020-0400X050-HP818	31154572
1,00	0,2	5	4	50	1,2	0,94	5,55	5,70	5,84	6,76	A	MCR107-010-0020-0500X050-HP818	31154573

OptiMill®-3D-CR-Hardened | MCR107 | Corner radius milling cutter, design with neck, z=2

Dimensions							Working depth at x° incline				Type	Specification	Order no.
d ₁	R	l ₃	d ₂ h5	l ₁	l ₂	d ₃	0.5°	1°	1.5°	3°			
1,00	0,2	6	4	50	1,2	0,94	6,58	6,75	6,98	8,09	A	MCR107-010-0020-0600X050-HP818	31154574
1,00	0,2	8	4	50	1,2	0,94	8,64	8,85	9,26	10,74	A	MCR107-010-0020-0800X050-HP818	31154575
1,00	0,2	10	4	50	1,2	0,94	10,69	11,03	11,54	13,40	A	MCR107-010-0020-1000X050-HP818	31154576
1,00	0,2	10	6	60	1,2	0,94	10,69	11,03	11,54	13,40	A	MCR107-010-0020-1000X060-HP818	31154577
1,00	0,2	12	6	60	1,2	0,94	12,73	13,21	13,82	16,05	A	MCR107-010-0020-1200X060-HP818	31154578
1,00	0,2	15	6	60	1,2	0,94	15,80	16,48	17,24	20,03	A	MCR107-010-0020-1500X060-HP818	31154579
1,50	0,2	5	4	50	1,7	1,44	5,55	5,70	5,84	6,76	A	MCR107-015-0020-0500X050-HP818	31154580
1,50	0,2	6	4	50	1,7	1,44	6,58	6,75	6,98	8,09	A	MCR107-015-0020-0600X050-HP818	31154581
1,50	0,2	8	4	50	1,7	1,44	8,64	8,85	9,26	10,74	A	MCR107-015-0020-0800X050-HP818	31154582
1,50	0,2	10	4	50	1,7	1,44	10,69	11,03	11,54	13,40	A	MCR107-015-0020-1000X050-HP818	31154583
1,50	0,2	10	6	60	1,7	1,44	10,69	11,03	11,54	13,40	A	MCR107-015-0020-1000X060-HP818	31154584
1,50	0,2	12	4	50	1,7	1,44	12,73	13,21	13,82	16,05	A	MCR107-015-0020-1200X050-HP818	31154585
1,50	0,2	12	6	60	1,7	1,44	12,73	13,21	13,82	16,05	A	MCR107-015-0020-1200X060-HP818	31154586
1,50	0,2	15	4	50	1,7	1,44	15,80	16,48	17,24	20,03	A	MCR107-015-0020-1500X050-HP818	31154587
1,50	0,2	15	6	60	1,7	1,44	15,80	16,48	17,24	20,03	A	MCR107-015-0020-1500X060-HP818	31154588
2,00	0,2	6	4	50	2,3	1,94	7,03	7,35	7,63	8,29	A	MCR107-020-0020-0600X050-HP808	31154594
2,00	0,2	8	4	50	2,3	1,94	9,13	9,51	9,82	10,74	A	MCR107-020-0020-0800X050-HP808	31154595
2,00	0,2	10	4	50	2,3	1,94	11,22	11,64	11,99	13,40	A	MCR107-020-0020-1000X050-HP808	31154596
2,00	0,2	12	4	50	2,3	1,94	13,31	13,77	14,14	16,05	A	MCR107-020-0020-1200X050-HP808	31154597
2,00	0,2	15	4	50	2,3	1,94	16,42	16,94	17,35	19,85	A	MCR107-020-0020-1500X050-HP808	31154598
2,00	0,2	15	6	60	2,3	1,94	16,42	16,94	17,35	20,03	A	MCR107-020-0020-1500X060-HP808	31154599
2,00	0,2	18	4	50	2,3	1,94	19,53	20,09	20,66	22,85	A	MCR107-020-0020-1800X050-HP808	31154600
2,00	0,2	20	4	50	2,3	1,94	21,60	22,19	22,94	24,85	A	MCR107-020-0020-2000X050-HP808	31154601
2,00	0,2	20	6	75	2,3	1,94	21,60	22,19	22,94	26,67	A	MCR107-020-0020-2000X075-HP808	31154602
2,00	0,2	25	6	75	2,3	1,94	26,75	27,41	28,65	33,30	A	MCR107-020-0020-2500X075-HP808	31154603
2,00	0,5	6	4	50	2,3	1,94	7,02	7,33	7,60	8,25	A	MCR107-020-0050-0600X050-HP808	31154604
2,00	0,5	8	4	50	2,3	1,94	9,12	9,49	9,79	10,65	A	MCR107-020-0050-0800X050-HP808	31154605
2,00	0,5	10	4	50	2,3	1,94	11,21	11,63	11,96	13,30	A	MCR107-020-0050-1000X050-HP808	31154606
2,00	0,5	12	4	50	2,3	1,94	13,30	13,75	14,12	15,95	A	MCR107-020-0050-1200X050-HP808	31154607
2,00	0,5	15	4	50	2,3	1,94	16,41	16,92	17,33	19,85	A	MCR107-020-0050-1500X050-HP808	31154608
2,00	0,5	15	6	60	2,3	1,94	16,41	16,92	17,33	19,94	A	MCR107-020-0050-1500X060-HP808	31154609
2,00	0,5	18	4	50	2,3	1,94	19,52	20,08	20,62	22,85	A	MCR107-020-0050-1800X050-HP808	31154610
2,00	0,5	20	4	50	2,3	1,94	21,59	22,18	22,90	24,85	A	MCR107-020-0050-2000X050-HP808	31154611
2,00	0,5	20	6	75	2,3	1,94	21,59	22,18	22,90	26,57	A	MCR107-020-0050-2000X075-HP808	31154612
2,00	0,5	25	6	75	2,3	1,94	26,74	27,40	28,60	33,21	A	MCR107-020-0050-2500X075-HP808	31154613
2,50	0,5	8	4	50	2,9	2,44	9,12	9,49	9,79	10,65	A	MCR107-025-0050-0800X050-HP808	31154614
2,50	0,5	10	4	50	2,9	2,44	11,21	11,63	11,96	13,30	A	MCR107-025-0050-1000X050-HP808	31154615
2,50	0,5	15	4	50	2,9	2,44	16,41	16,92	17,33	18,67	A	MCR107-025-0050-1500X050-HP808	31154616
2,50	0,5	15	6	60	2,9	2,44	16,41	16,92	17,33	19,94	A	MCR107-025-0050-1500X060-HP808	31154617
2,50	0,5	20	4	50	2,9	2,44	21,59	22,18	22,90	23,67	A	MCR107-025-0050-2000X050-HP808	31154618
2,50	0,5	20	6	75	2,9	2,44	21,59	22,18	22,90	26,57	A	MCR107-025-0050-2000X075-HP808	31154620
3,00	0,2	10	6	60	3,5	2,94	11,22	11,64	11,99	13,40	A	MCR107-030-0020-1000X060-HP808	31154622
3,00	0,2	15	6	60	3,5	2,94	16,42	16,94	17,35	20,03	A	MCR107-030-0020-1500X060-HP808	31154623
3,00	0,2	20	6	60	3,5	2,94	21,60	22,19	22,94	26,67	A	MCR107-030-0020-2000X060-HP808	31154624
3,00	0,2	25	6	75	3,5	2,94	26,75	27,41	28,65	32,20	A	MCR107-030-0020-2500X075-HP808	31154625
3,00	0,5	10	6	60	3,5	2,94	11,21	11,63	11,96	13,30	A	MCR107-030-0050-1000X060-HP808	31154626
3,00	0,5	15	6	60	3,5	2,94	16,41	16,92	17,33	19,94	A	MCR107-030-0050-1500X060-HP808	31154627
3,00	0,5	20	6	60	3,5	2,94	21,59	22,18	22,90	26,57	A	MCR107-030-0050-2000X060-HP808	31154628
3,00	0,5	25	6	75	3,5	2,94	26,74	27,40	28,60	32,20	A	MCR107-030-0050-2500X075-HP808	31154629
4,00	0,2	10	6	60	4,6	3,94	11,22	11,64	11,99	13,40	A	MCR107-040-0020-1000X060-HP808	31154630
4,00	0,2	15	6	60	4,6	3,94	16,42	16,94	17,35	19,85	A	MCR107-040-0020-1500X060-HP808	31154631
4,00	0,2	20	6	60	4,6	3,94	21,60	22,19	22,94	24,85	A	MCR107-040-0020-2000X060-HP808	31154632
4,00	0,2	25	6	75	4,6	3,94	26,75	27,41	28,65	29,85	A	MCR107-040-0020-2500X075-HP808	31154633
4,00	0,2	30	6	75	4,6	3,94	31,89	32,82	34,35	34,85	A	MCR107-040-0020-3000X075-HP808	31154634
4,00	0,2	35	6	75	4,6	3,94	37,02	38,27	39,85	-	A	MCR107-040-0020-3500X075-HP808	31154635
4,00	0,5	10	6	60	4,6	3,94	11,21	11,63	11,96	13,30	A	MCR107-040-0050-1000X060-HP808	31154636
4,00	0,5	15	6	60	4,6	3,94	16,41	16,92	17,33	19,85	A	MCR107-040-0050-1500X060-HP808	31154637

Continued on next page.

OptiMill®-3D-CR-Hardened | MCR107 | Corner radius milling cutter, design with neck, z=2

Dimensions							Working depth at x° incline				Type	Specification	Order no.
d ₁	R	l ₃	d ₂ h5	l ₁	l ₂	d ₃	0.5°	1°	1.5°	3°			
4,00	0,5	20	6	60	4,6	3,94	21,59	22,18	22,90	24,85	A	MCR107-040-0050-2000X060-HP808	31154638
4,00	0,5	25	6	75	4,6	3,94	26,74	27,40	28,60	29,85	A	MCR107-040-0050-2500X075-HP808	31154639
4,00	0,5	30	6	75	4,6	3,94	31,89	32,79	34,31	34,85	A	MCR107-040-0050-3000X075-HP808	31154640
4,00	0,5	35	6	75	4,6	3,94	37,02	38,24	39,85	-	A	MCR107-040-0050-3500X075-HP808	31154641
5,00	0,2	15	6	60	5,8	4,9	15,88	16,58	17,35	17,59	C	MCR107-050-0020-1500X060-HP808	31154642
5,00	0,2	20	6	60	5,8	4,9	21,09	22,03	22,59	-	C	MCR107-050-0020-2000X060-HP808	31154643
5,00	0,2	25	6	60	5,8	4,9	26,31	27,48	27,59	-	C	MCR107-050-0020-2500X060-HP808	31154644
5,00	0,2	30	6	75	5,8	4,9	31,52	32,59	-	-	C	MCR107-050-0020-3000X075-HP808	31154645
5,00	0,5	15	6	60	5,8	4,9	15,87	16,55	17,31	17,59	C	MCR107-050-0050-1500X060-HP808	31154646
5,00	0,5	20	6	60	5,8	4,9	21,08	22,00	22,59	-	C	MCR107-050-0050-2000X060-HP808	31154647
5,00	0,5	25	6	60	5,8	4,9	26,29	27,45	27,59	-	C	MCR107-050-0050-2500X060-HP808	31154648
5,00	0,5	30	6	75	5,8	4,9	31,51	32,59	-	-	C	MCR107-050-0050-3000X075-HP808	31154649
6,00	0,2	15	6	60	6,9	5,9	-	-	-	-	-	MCR107-060-0020-1500X060-HP808	31154650
6,00	0,2	20	6	60	6,9	5,9	-	-	-	-	-	MCR107-060-0020-2000X060-HP808	31154651
6,00	0,2	25	6	60	6,9	5,9	-	-	-	-	-	MCR107-060-0020-2500X060-HP808	31154652
6,00	0,2	30	6	75	6,9	5,9	-	-	-	-	-	MCR107-060-0020-3000X075-HP808	31154653
6,00	0,2	35	6	75	6,9	5,9	-	-	-	-	-	MCR107-060-0020-3500X075-HP808	31154654
6,00	0,3	15	6	60	6,9	5,9	-	-	-	-	-	MCR107-060-0030-1500X060-HP808	31154655
6,00	0,3	20	6	60	6,9	5,9	-	-	-	-	-	MCR107-060-0030-2000X060-HP808	31154656
6,00	0,3	25	6	60	6,9	5,9	-	-	-	-	-	MCR107-060-0030-2500X060-HP808	31154657
6,00	0,3	30	6	75	6,9	5,9	-	-	-	-	-	MCR107-060-0030-3000X075-HP808	31154658
6,00	0,3	35	6	75	6,9	5,9	-	-	-	-	-	MCR107-060-0030-3500X075-HP808	31154659
6,00	0,5	15	6	60	6,9	5,9	-	-	-	-	-	MCR107-060-0050-1500X060-HP808	31154660
6,00	0,5	20	6	60	6,9	5,9	-	-	-	-	-	MCR107-060-0050-2000X060-HP808	31154661
6,00	0,5	25	6	60	6,9	5,9	-	-	-	-	-	MCR107-060-0050-2500X060-HP808	31154662
6,00	0,5	30	6	75	6,9	5,9	-	-	-	-	-	MCR107-060-0050-3000X075-HP808	31154663
6,00	0,5	35	6	75	6,9	5,9	-	-	-	-	-	MCR107-060-0050-3500X075-HP808	31154664
6,00	1	15	6	60	6,9	5,9	-	-	-	-	-	MCR107-060-0100-1500X060-HP808	31154665
6,00	1	20	6	60	6,9	5,9	-	-	-	-	-	MCR107-060-0100-2000X060-HP808	31154666
6,00	1	25	6	60	6,9	5,9	-	-	-	-	-	MCR107-060-0100-2500X060-HP808	31154667
6,00	1	30	6	75	6,9	5,9	-	-	-	-	-	MCR107-060-0100-3000X075-HP808	31154668
6,00	1	35	6	75	6,9	5,9	-	-	-	-	-	MCR107-060-0100-3500X075-HP808	31154669
8,00	0,5	25	8	64	9,2	7,8	-	-	-	-	-	MCR107-080-0050-2500X064-HP808	31154670
8,00	0,5	50	8	100	9,2	7,8	-	-	-	-	-	MCR107-080-0050-5000X100-HP808	31154671
8,00	1	25	8	64	9,2	7,8	-	-	-	-	-	MCR107-080-0100-2500X064-HP808	31154672
8,00	1	50	8	100	9,2	7,8	-	-	-	-	-	MCR107-080-0100-5000X100-HP808	31154673
8,00	2	25	8	64	9,2	7,8	-	-	-	-	-	MCR107-080-0200-2500X064-HP808	31154674
8,00	2	50	8	100	9,2	7,8	-	-	-	-	-	MCR107-080-0200-5000X100-HP808	31154675
10,00	0,5	30	10	75	11,5	9,8	-	-	-	-	-	MCR107-100-0050-3000X075-HP808	31154676
10,00	0,5	50	10	100	11,5	9,8	-	-	-	-	-	MCR107-100-0050-5000X100-HP808	31154677
10,00	1	30	10	75	11,5	9,8	-	-	-	-	-	MCR107-100-0100-3000X075-HP808	31154678
10,00	1	50	10	100	11,5	9,8	-	-	-	-	-	MCR107-100-0100-5000X100-HP808	31154679
10,00	2	30	10	75	11,5	9,8	-	-	-	-	-	MCR107-100-0200-3000X075-HP808	31154680
10,00	2	50	10	100	11,5	9,8	-	-	-	-	-	MCR107-100-0200-5000X100-HP808	31154681
12,00	0,5	35	12	75	13,8	11,8	-	-	-	-	-	MCR107-120-0050-3500X075-HP808	31154682
12,00	0,5	60	12	100	13,8	11,8	-	-	-	-	-	MCR107-120-0050-6000X100-HP808	31154683
12,00	1	35	12	75	13,8	11,8	-	-	-	-	-	MCR107-120-0100-3500X075-HP808	31154684
12,00	1	60	12	100	13,8	11,8	-	-	-	-	-	MCR107-120-0100-6000X100-HP808	31154685
12,00	2	35	12	75	13,8	11,8	-	-	-	-	-	MCR107-120-0200-3500X075-HP808	31154686
12,00	2	60	12	100	13,8	11,8	-	-	-	-	-	MCR107-120-0200-6000X100-HP808	31154687

Available on request

Dimensions							Working depth at x° incline				Type	Specification	Order no.
d ₁	R	l ₃	d ₂ h5	l ₁	l ₂	d ₃	0.5°	1°	1.5°	3°			
0,10	0,02	0,3	6	60	0,1	0,075	0,56	0,60	0,64	0,75	A	MCR107-001-0002-0030X060-HP818	31154523
0,10	0,02	0,4	4	50	0,1	0,075	0,67	0,71	0,75	0,88	A	MCR107-001-0002-0040X050-HP818	31154524
0,10	0,02	0,4	6	60	0,1	0,075	0,67	0,71	0,75	0,88	A	MCR107-001-0002-0040X060-HP818	31154525
0,20	0,05	0,5	4	50	0,2	0,17	0,79	0,84	0,88	1,01	A	MCR107-002-0005-0050X050-HP818	31154526
0,20	0,05	0,75	4	50	0,2	0,17	1,06	1,12	1,17	1,31	A	MCR107-002-0005-0075X050-HP818	31154528
0,20	0,05	1	4	50	0,2	0,17	1,32	1,39	1,45	1,62	A	MCR107-002-0005-0100X050-HP818	31154529
0,20	0,05	1	6	60	0,2	0,17	1,32	1,39	1,45	1,62	A	MCR107-002-0005-0100X060-HP818	31154530
0,20	0,05	1,25	4	50	0,2	0,17	1,59	1,66	1,73	1,91	A	MCR107-002-0005-0125X050-HP818	31154531
0,20	0,05	1,5	4	50	0,2	0,17	1,85	1,94	2,01	2,20	A	MCR107-002-0005-0150X050-HP818	31154532
0,20	0,05	1,5	6	60	0,2	0,17	1,85	1,94	2,01	2,20	A	MCR107-002-0005-0150X060-HP818	31154533
0,30	0,05	0,75	4	50	0,3	0,27	1,06	1,12	1,17	1,31	A	MCR107-003-0005-0075X050-HP818	31154535
0,30	0,05	1	4	50	0,3	0,27	1,32	1,39	1,45	1,62	A	MCR107-003-0005-0100X050-HP818	31154536
0,30	0,05	1	6	60	0,3	0,27	1,32	1,39	1,45	1,62	A	MCR107-003-0005-0100X060-HP818	31154537
0,30	0,05	1,25	4	50	0,3	0,27	1,59	1,66	1,73	1,91	A	MCR107-003-0005-0125X050-HP818	31154538
0,30	0,05	1,5	4	50	0,3	0,27	1,85	1,94	2,01	2,20	A	MCR107-003-0005-0150X050-HP818	31154539
0,30	0,05	1,5	6	60	0,3	0,27	1,85	1,94	2,01	2,20	A	MCR107-003-0005-0150X060-HP818	31154540
0,30	0,05	2	6	60	0,3	0,27	2,37	2,48	2,56	2,78	A	MCR107-003-0005-0200X060-HP818	31154541
1,80	0,2	6	4	50	2,1	1,74	6,58	6,75	6,98	8,09	A	MCR107-018-0020-0600X050-HP818	31154589
1,80	0,2	8	4	50	2,1	1,74	8,64	8,85	9,26	10,74	A	MCR107-018-0020-0800X050-HP818	31154590
1,80	0,2	10	4	50	2,1	1,74	10,69	11,03	11,54	13,40	A	MCR107-018-0020-1000X050-HP818	31154591
1,80	0,2	15	4	50	2,1	1,74	15,80	16,48	17,24	20,03	A	MCR107-018-0020-1500X050-HP818	31154592
1,80	0,2	20	4	50	2,1	1,74	20,99	21,93	22,94	25,32	A	MCR107-018-0020-2000X050-HP818	31154593
2,50	0,5	25	6	75	2,9	2,44	26,74	27,40	28,60	33,21	A	MCR107-025-0050-2500X075-HP808	31154621

Dimensions in mm.

For cutting data recommendations, see end of chapter.

Special designs and other coatings available upon request.

OptiMill®-3D-CR-Hardened

Corner radius milling cutter, z=4
MCR108

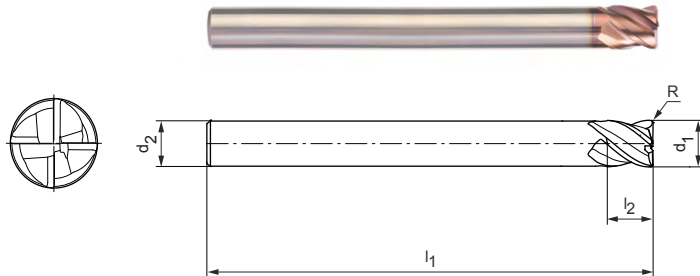

Design:

Diameter of milling cutter: 6.00 - 12.00 mm
Cutting material: HP808
Number of cutting edges: 4
Helix angle: 42°
Radial contour tolerance: ± 0.005 if $d_1 \leq 6$ mm
 ± 0.01 if $d_1 > 6$ mm

Application:

Suitable for machining workpiece materials up to 68 HRC.



Preferred series in stock

Dimensions					z	Specification	Order no.
d ₁	R	d ₂ h5	l ₁	l ₂			
6,00	0,2	6	60	6,9	4	MCR108-060-0020-X060-HP808	31154688
6,00	0,2	6	100	6,9	4	MCR108-060-0020-X100-HP808	31154689
6,00	0,3	6	60	6,9	4	MCR108-060-0030-X060-HP808	31154690
6,00	0,3	6	100	6,9	4	MCR108-060-0030-X100-HP808	31154691
6,00	0,5	6	75	6,9	4	MCR108-060-0050-X075-HP808	31154692
6,00	0,5	6	100	6,9	4	MCR108-060-0050-X100-HP808	31154693
6,00	1	6	75	6,9	4	MCR108-060-0100-X075-HP808	31154694
6,00	1	6	100	6,9	4	MCR108-060-0100-X100-HP808	31154695
8,00	0,5	8	64	9,2	4	MCR108-080-0050-X064-HP808	31154696
8,00	0,5	8	100	9,2	4	MCR108-080-0050-X100-HP808	31154697
8,00	1	8	64	9,2	4	MCR108-080-0100-X064-HP808	31154698
8,00	1	8	100	9,2	4	MCR108-080-0100-X100-HP808	31154699
8,00	2	8	64	9,2	4	MCR108-080-0200-X064-HP808	31154700
8,00	2	8	100	9,2	4	MCR108-080-0200-X100-HP808	31154701
10,00	0,5	10	75	11,5	4	MCR108-100-0050-X075-HP808	31154702
10,00	0,5	10	120	11,5	4	MCR108-100-0050-X120-HP808	31154703
10,00	1	10	75	11,5	4	MCR108-100-0100-X075-HP808	31154704
10,00	1	10	120	11,5	4	MCR108-100-0100-X120-HP808	31154705
10,00	2	10	75	11,5	4	MCR108-100-0200-X075-HP808	31154706
10,00	2	10	120	11,5	4	MCR108-100-0200-X120-HP808	31154707
12,00	0,5	12	75	13,8	4	MCR108-120-0050-X075-HP808	31154708
12,00	0,5	12	120	13,8	4	MCR108-120-0050-X120-HP808	31154709
12,00	1	12	75	13,8	4	MCR108-120-0100-X075-HP808	31154710
12,00	1	12	120	13,8	4	MCR108-120-0100-X120-HP808	31154711
12,00	2	12	75	13,8	4	MCR108-120-0200-X075-HP808	31154712
12,00	2	12	120	13,8	4	MCR108-120-0200-X120-HP808	31154713

Dimensions in mm.

For cutting data recommendations, see end of chapter.

Special designs and other coatings available upon request.

OptiMill®-3D-CR-Hardened

Corner radius milling cutter, design with neck, z=4
MCR109

Design:

Diameter of milling cutter: 3.00 - 12.00 mm
Cutting material: HP808
Number of cutting edges: 4
Helix angle: 42°
Radial contour tolerance: ±0.005 if $d_1 \leq 6$ mm
±0.01 if $d_1 > 6$ mm

Application:

Suitable for machining workpiece materials up to 68 HRC.

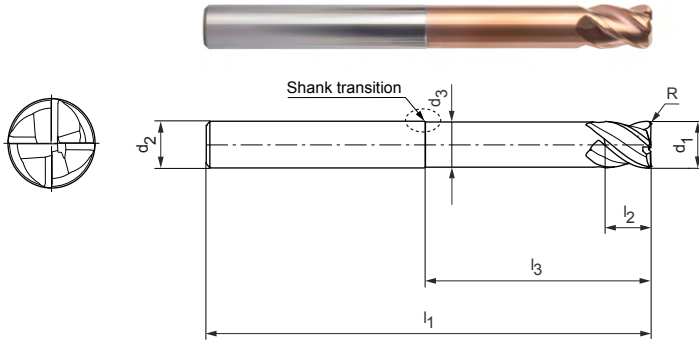

Shank transition:

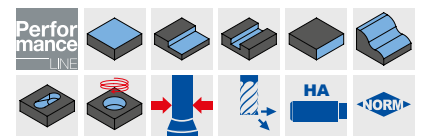
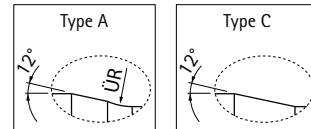

Preferred series in stock

Dimensions							Working depth at x° incline				Type	Specification	Order no.
d ₁	R	l ₃	d ₂ h5	l ₁	l ₂	d ₃	0.5°	1°	1.5°	3°			
3,00	0,2	10	6	60	3,5	2,94	11,22	11,64	11,99	13,40	A	MCR109-030-0020-1000X060-HP808	31154714
3,00	0,2	15	6	60	3,5	2,94	16,42	16,94	17,35	20,03	A	MCR109-030-0020-1500X060-HP808	31154715
3,00	0,2	20	6	60	3,5	2,94	21,60	22,19	22,94	26,67	A	MCR109-030-0020-2000X060-HP808	31154716
3,00	0,2	25	6	75	3,5	2,94	26,75	27,41	28,65	32,20	A	MCR109-030-0020-2500X075-HP808	31154717
3,00	0,5	10	6	60	3,5	2,94	11,21	11,63	11,96	13,30	A	MCR109-030-0050-1000X060-HP808	31154718
3,00	0,5	15	6	60	3,5	2,94	16,41	16,92	17,33	19,94	A	MCR109-030-0050-1500X060-HP808	31154719
3,00	0,5	20	6	60	3,5	2,94	21,59	22,18	22,90	26,57	A	MCR109-030-0050-2000X060-HP808	31154720
3,00	0,5	25	6	75	3,5	2,94	26,74	27,40	28,60	32,20	A	MCR109-030-0050-2500X075-HP808	31154721
4,00	0,2	10	6	60	4,6	3,94	11,22	11,64	11,99	13,40	A	MCR109-040-0020-1000X060-HP808	31154722
4,00	0,2	15	6	60	4,6	3,94	16,42	16,94	17,35	19,85	A	MCR109-040-0020-1500X060-HP808	31154723
4,00	0,2	20	6	60	4,6	3,94	21,60	22,19	22,94	24,85	A	MCR109-040-0020-2000X060-HP808	31154724
4,00	0,2	25	6	75	4,6	3,94	26,75	27,41	28,65	29,85	A	MCR109-040-0020-2500X075-HP808	31154725
4,00	0,2	30	6	75	4,6	3,94	31,89	32,82	34,35	34,85	A	MCR109-040-0020-3000X075-HP808	31154726
4,00	0,5	10	6	60	4,6	3,94	11,21	11,63	11,96	13,30	A	MCR109-040-0050-1000X060-HP808	31154727
4,00	0,5	15	6	60	4,6	3,94	16,41	16,92	17,33	19,85	A	MCR109-040-0050-1500X060-HP808	31154728
4,00	0,5	20	6	60	4,6	3,94	21,59	22,18	22,90	24,85	A	MCR109-040-0050-2000X060-HP808	31154729
4,00	0,5	25	6	75	4,6	3,94	26,74	27,40	28,60	29,85	A	MCR109-040-0050-2500X075-HP808	31154730
4,00	0,5	30	6	75	4,6	3,94	31,89	32,79	34,31	34,85	A	MCR109-040-0050-3000X075-HP808	31154731
5,00	0,2	15	6	60	5,8	4,9	15,88	16,58	17,35	17,59	C	MCR109-050-0020-1500X060-HP808	31154732
5,00	0,2	20	6	60	5,8	4,9	21,09	22,03	22,59	-	C	MCR109-050-0020-2000X060-HP808	31154733
5,00	0,2	25	6	60	5,8	4,9	26,31	27,48	27,59	-	C	MCR109-050-0020-2500X060-HP808	31154734
5,00	0,2	30	6	75	5,8	4,9	31,52	32,59	-	-	C	MCR109-050-0020-3000X075-HP808	31154735
5,00	0,5	15	6	60	5,8	4,9	15,87	16,55	17,31	17,59	C	MCR109-050-0050-1500X060-HP808	31154736
5,00	0,5	20	6	60	5,8	4,9	21,08	22,00	22,59	-	C	MCR109-050-0050-2000X060-HP808	31154737
5,00	0,5	25	6	60	5,8	4,9	26,29	27,45	27,59	-	C	MCR109-050-0050-2500X060-HP808	31154738
5,00	0,5	30	6	75	5,8	4,9	31,51	32,59	-	-	C	MCR109-050-0050-3000X075-HP808	31154739
6,00	0,2	15	6	60	6,9	5,9	-	-	-	-	-	MCR109-060-0020-1500X060-HP808	31154740
6,00	0,2	20	6	60	6,9	5,9	-	-	-	-	-	MCR109-060-0020-2000X060-HP808	31154741
6,00	0,2	25	6	60	6,9	5,9	-	-	-	-	-	MCR109-060-0020-2500X060-HP808	31154742
6,00	0,2	30	6	75	6,9	5,9	-	-	-	-	-	MCR109-060-0020-3000X075-HP808	31154743
6,00	0,2	35	6	75	6,9	5,9	-	-	-	-	-	MCR109-060-0020-3500X075-HP808	31154744
6,00	0,3	15	6	60	6,9	5,9	-	-	-	-	-	MCR109-060-0030-1500X060-HP808	31154745
6,00	0,3	20	6	60	6,9	5,9	-	-	-	-	-	MCR109-060-0030-2000X060-HP808	31154746
6,00	0,3	25	6	60	6,9	5,9	-	-	-	-	-	MCR109-060-0030-2500X060-HP808	31154747
6,00	0,3	30	6	75	6,9	5,9	-	-	-	-	-	MCR109-060-0030-3000X075-HP808	31154748

OptiMill®-3D-CR-Hardened | MCR109 | Corner radius milling cutter, design with neck, z=4

Dimensions							Working depth at x° incline				Type	Specification	Order no.
d ₁	R	l ₃	d ₂ h5	l ₁	l ₂	d ₃	0.5°	1°	1.5°	3°			
6,00	0,3	35	6	75	6,9	5,9	-	-	-	-	-	MCR109-060-0030-3500X075-HP808	31154749
6,00	0,5	15	6	60	6,9	5,9	-	-	-	-	-	MCR109-060-0050-1500X060-HP808	31154750
6,00	0,5	20	6	60	6,9	5,9	-	-	-	-	-	MCR109-060-0050-2000X060-HP808	31154751
6,00	0,5	25	6	60	6,9	5,9	-	-	-	-	-	MCR109-060-0050-2500X060-HP808	31154752
6,00	0,5	30	6	75	6,9	5,9	-	-	-	-	-	MCR109-060-0050-3000X075-HP808	31154753
6,00	0,5	35	6	75	6,9	5,9	-	-	-	-	-	MCR109-060-0050-3500X075-HP808	31154754
6,00	1	15	6	60	6,9	5,9	-	-	-	-	-	MCR109-060-0100-1500X060-HP808	31154755
6,00	1	20	6	60	6,9	5,9	-	-	-	-	-	MCR109-060-0100-2000X060-HP808	31154756
6,00	1	25	6	60	6,9	5,9	-	-	-	-	-	MCR109-060-0100-2500X060-HP808	31154757
6,00	1	30	6	75	6,9	5,9	-	-	-	-	-	MCR109-060-0100-3000X075-HP808	31154758
6,00	1	35	6	75	6,9	5,9	-	-	-	-	-	MCR109-060-0100-3500X075-HP808	31154759
8,00	0,5	25	8	64	9,2	7,8	-	-	-	-	-	MCR109-080-0050-2500X064-HP808	31154760
8,00	0,5	50	8	100	9,2	7,8	-	-	-	-	-	MCR109-080-0050-5000X100-HP808	31154763
8,00	1	25	8	64	9,2	7,8	-	-	-	-	-	MCR109-080-0100-2500X064-HP808	31154761
8,00	1	50	8	100	9,2	7,8	-	-	-	-	-	MCR109-080-0100-5000X100-HP808	31154764
8,00	2	25	8	64	9,2	7,8	-	-	-	-	-	MCR109-080-0200-2500X064-HP808	31154762
8,00	2	50	8	100	9,2	7,8	-	-	-	-	-	MCR109-080-0200-5000X100-HP808	31154765
10,00	0,5	30	10	75	11,5	9,8	-	-	-	-	-	MCR109-100-0050-3000X075-HP808	31154766
10,00	0,5	50	10	100	11,5	9,8	-	-	-	-	-	MCR109-100-0050-5000X100-HP808	31154769
10,00	1	30	10	75	11,5	9,8	-	-	-	-	-	MCR109-100-0100-3000X075-HP808	31154767
10,00	1	50	10	100	11,5	9,8	-	-	-	-	-	MCR109-100-0100-5000X100-HP808	31154770
10,00	2	30	10	75	11,5	9,8	-	-	-	-	-	MCR109-100-0200-3000X075-HP808	31154768
10,00	2	50	10	100	11,5	9,8	-	-	-	-	-	MCR109-100-0200-5000X100-HP808	31154771
12,00	0,5	35	12	75	13,8	11,8	-	-	-	-	-	MCR109-120-0050-3500X075-HP808	31154772
12,00	0,5	60	12	100	13,8	11,8	-	-	-	-	-	MCR109-120-0050-6000X100-HP808	31154775
12,00	1	35	12	75	13,8	11,8	-	-	-	-	-	MCR109-120-0100-3500X075-HP808	31154773
12,00	1	60	12	100	13,8	11,8	-	-	-	-	-	MCR109-120-0100-6000X100-HP808	31154776
12,00	2	35	12	75	13,8	11,8	-	-	-	-	-	MCR109-120-0200-3500X075-HP808	31154774
12,00	2	60	12	100	13,8	11,8	-	-	-	-	-	MCR109-120-0200-6000X100-HP808	31154777

Dimensions in mm.

For cutting data recommendations, see end of chapter.

Special designs and other coatings available upon request.

OptiMill®-3D-CR-Hardened

Corner radius milling cutter, design with neck, z=5
MCR110

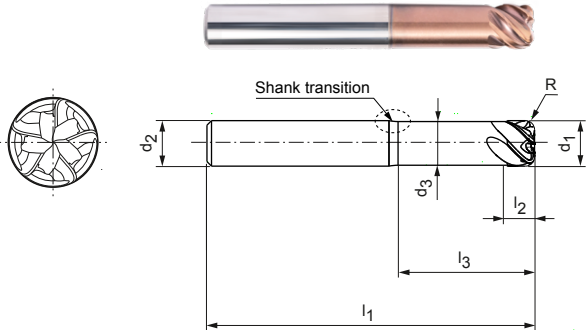

Design:

Diameter of milling cutter: 4.00 - 12.00 mm
Cutting material: HP808
Number of cutting edges: 5
Helix angle: ~47°
Radial contour tolerance: ±0.005 if d₁ ≤ 6 mm
±0.01 if d₁ > 6 mm

Application:

Highly efficient roughing of residual material. Finishing of moulds with first-class surface finishes up to high-gloss surfaces at maximum feed rates up to 66 HRC.

Shank transition:

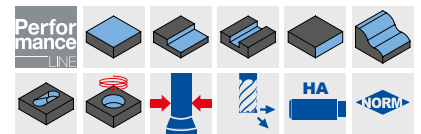
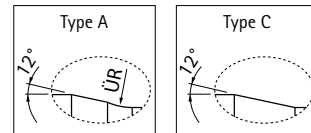

Preferred series in stock

Dimensions							Type	Specification	Order no.
d ₁	R	l ₃	d ₂ h5	l ₁	l ₂	d ₃			
4,00	0,5	12	6	60	4,2	3,94	A	MCR110-040-0050-1200X060-HP808	31151686
4,00	0,5	20	6	60	4,2	3,94	A	MCR110-040-0050-2000X060-HP808	31151687
4,00	1	12	6	60	4,2	3,94	A	MCR110-040-0100-1200X060-HP808	31151688
4,00	1	20	6	60	4,2	3,94	A	MCR110-040-0100-2000X060-HP808	31151689
5,00	0,5	15	6	60	5,2	4,9	C	MCR110-050-0050-1500X060-HP808	31151700
5,00	0,5	25	6	60	5,2	4,9	C	MCR110-050-0050-2500X060-HP808	31151701
5,00	1	15	6	60	5,2	4,9	C	MCR110-050-0100-1500X060-HP808	31151702
5,00	1	25	6	60	5,2	4,9	C	MCR110-050-0100-2500X060-HP808	31151703
6,00	0,5	18	6	60	6,3	5,9	-	MCR110-060-0050-1800X060-HP808	31151704
6,00	0,5	30	6	75	6,3	5,9	-	MCR110-060-0050-3000X075-HP808	31151705
6,00	1	18	6	60	6,3	5,9	-	MCR110-060-0100-1800X060-HP808	31151706
6,00	1	30	6	75	6,3	5,9	-	MCR110-060-0100-3000X075-HP808	31151707
8,00	0,5	24	8	64	8,4	7,8	-	MCR110-080-0050-2400X064-HP808	31151708
8,00	0,5	40	8	75	8,4	7,8	-	MCR110-080-0050-4000X075-HP808	31151709
8,00	1	24	8	64	8,4	7,8	-	MCR110-080-0100-2400X064-HP808	31151710
8,00	1	40	8	75	8,4	7,8	-	MCR110-080-0100-4000X075-HP808	31151711
8,00	2	24	8	64	8,4	7,8	-	MCR110-080-0200-2400X064-HP808	31385107
8,00	2	40	8	75	8,4	7,8	-	MCR110-080-0200-4000X075-HP808	31385108
10,00	1	30	10	75	10,5	9,8	-	MCR110-100-0100-3000X075-HP808	31151712
10,00	1	50	10	100	10,5	9,8	-	MCR110-100-0100-5000X100-HP808	31151713
10,00	2	30	10	75	10,5	9,8	-	MCR110-100-0200-3000X075-HP808	31151714
10,00	2	50	10	100	10,5	9,8	-	MCR110-100-0200-5000X100-HP808	31151715
10,00	3	30	10	75	10,5	9,8	-	MCR110-100-0300-3000X075-HP808	31385109
10,00	3	50	10	100	10,5	9,8	-	MCR110-100-0300-5000X100-HP808	31385150
12,00	1	36	12	100	12,5	11,8	-	MCR110-120-0100-3600X100-HP808	31151716
12,00	1	60	12	100	12,5	11,8	-	MCR110-120-0100-6000X100-HP808	31151717
12,00	2	36	12	100	12,5	11,8	-	MCR110-120-0200-3600X100-HP808	31151718
12,00	2	60	12	100	12,5	11,8	-	MCR110-120-0200-6000X100-HP808	31151719
12,00	3	36	12	100	12,5	11,8	-	MCR110-120-0300-3600X100-HP808	31385151
12,00	3	60	12	100	12,5	11,8	-	MCR110-120-0300-6000X100-HP808	31385152

Dimensions in mm.

For cutting data recommendations, see end of chapter.

Special designs and other coatings available upon request.

OptiMill®-3D-CR-Graphite

Corner radius milling cutter, design with neck, z=2
MCR111/MCR112

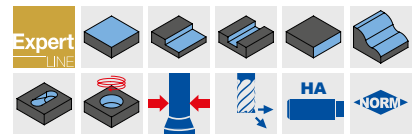
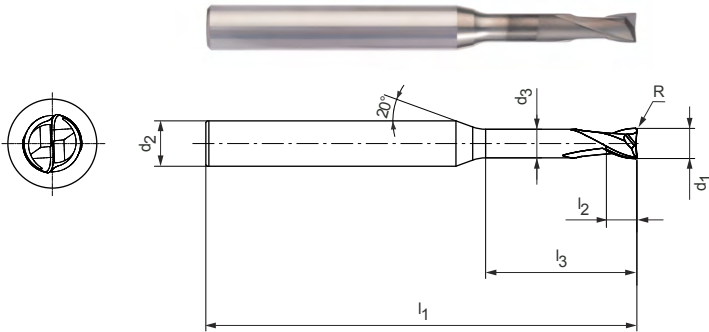

Design:

Diameter of milling cutter: 0.40 - 4.00 mm
Cutting material: HC115/HC116
Number of cutting edges: 2
Helix angle: 30°
Radial contour tolerance: ±0.005
Special features: Diamond coating

Application:

Suitable for machining of graphite electrodes. Mainly used for finishing and pre-finishing due to narrowed radius tolerance.

Preferred series available from stock | Normal cutting edge length | MCR111

Dimensions							z	Specification	Order no.
d ₁	R	l ₃	d ₂ h5	l ₁	l ₂	d ₃			
0,40	0,05	2,5	4	50	0,6	0,37	2	MCR111-004-0005-0250X050-HC115	31152894
0,40	0,05	5	4	50	0,6	0,37	2	MCR111-004-0005-0500X050-HC115	31152895
0,50	0,05	3,5	4	50	0,8	0,45	2	MCR111-005-0005-0350X050-HC115	31152896
0,50	0,05	5	4	50	0,8	0,45	2	MCR111-005-0005-0500X050-HC115	31152897
0,50	0,05	7	4	50	0,8	0,45	2	MCR111-005-0005-0700X050-HC115	31152898
0,50	0,05	10	4	50	0,8	0,45	2	MCR111-005-0005-1000X050-HC115	31152899
0,60	0,05	3,5	4	50	0,9	0,55	2	MCR111-006-0005-0350X050-HC115	31152900
0,60	0,05	7	4	50	0,9	0,55	2	MCR111-006-0005-0700X050-HC115	31152901
0,60	0,05	9	4	50	0,9	0,55	2	MCR111-006-0005-0900X050-HC115	31152902
0,60	0,05	12	4	50	0,9	0,55	2	MCR111-006-0005-1200X050-HC115	31152903
0,80	0,05	5	4	50	1,2	0,75	2	MCR111-008-0005-0500X050-HC115	31152904
0,80	0,05	10	4	50	1,2	0,75	2	MCR111-008-0005-1000X050-HC115	31152905
0,80	0,05	12	4	50	1,2	0,75	2	MCR111-008-0005-1200X050-HC115	31152906
0,80	0,05	16	4	50	1,2	0,75	2	MCR111-008-0005-1600X050-HC115	31152907
1,00	0,1	5	4	50	1,5	0,95	2	MCR111-010-0010-0500X050-HC116	31152908
1,00	0,1	10	4	50	1,5	0,95	2	MCR111-010-0010-1000X050-HC116	31152909
1,00	0,1	15	4	50	1,5	0,95	2	MCR111-010-0010-1500X050-HC116	31152910
1,00	0,1	20	4	75	1,5	0,95	2	MCR111-010-0010-2000X075-HC116	31152911
1,00	0,2	10	4	50	1,5	0,95	2	MCR111-010-0020-1000X050-HC116	31152912
1,00	0,2	15	4	50	1,5	0,95	2	MCR111-010-0020-1500X050-HC116	31152913
1,00	0,2	20	4	75	1,5	0,95	2	MCR111-010-0020-2000X075-HC116	31152914
1,50	0,1	10	4	50	2,3	1,4	2	MCR111-015-0010-1000X050-HC116	31152915
1,50	0,1	15	4	50	2,3	1,4	2	MCR111-015-0010-1500X050-HC116	31152916
1,50	0,1	20	4	50	2,3	1,4	2	MCR111-015-0010-2000X050-HC116	31152917
1,50	0,15	10	4	50	2,3	1,4	2	MCR111-015-0015-1000X050-HC116	31152918
1,50	0,15	15	4	50	2,3	1,4	2	MCR111-015-0015-1500X050-HC116	31152919
1,50	0,15	20	4	50	2,3	1,4	2	MCR111-015-0015-2000X050-HC116	31152920
1,50	0,2	10	4	50	2,3	1,4	2	MCR111-015-0020-1000X050-HC116	31152921
1,50	0,2	15	4	50	2,3	1,4	2	MCR111-015-0020-1500X050-HC116	31152922
1,50	0,2	20	4	75	2,3	1,4	2	MCR111-015-0020-2000X075-HC116	31152923
2,00	0,2	5	4	50	3	1,9	2	MCR111-020-0020-0500X050-HC116	31152924
2,00	0,2	10	4	50	3	1,9	2	MCR111-020-0020-1000X050-HC116	31152925
2,00	0,2	15	4	50	3	1,9	2	MCR111-020-0020-1500X050-HC116	31152926
2,00	0,2	20	4	75	3	1,9	2	MCR111-020-0020-2000X075-HC116	31152927
2,00	0,2	25	4	75	3	1,9	2	MCR111-020-0020-2500X075-HC116	31152929

OptiMill®-3D-CR-Graphite | Normal cutting edge length | MCR111 | Corner radius milling cutter, design with neck, z=2

Dimensions							z	Specification	Order no.
d ₁	R	l ₃	d ₂	l ₁	l ₂	d ₃			
2,00	0,2	30	4	75	3	1,9	2	MCR111-020-0020-3000X075-HC116	31152930
2,00	0,5	10	4	50	3	1,9	2	MCR111-020-0050-1000X050-HC116	31152931
2,00	0,5	15	4	50	3	1,9	2	MCR111-020-0050-1500X050-HC116	31152932
2,00	0,5	20	4	75	3	1,9	2	MCR111-020-0050-2000X075-HC116	31152933
2,00	0,5	25	4	75	3	1,9	2	MCR111-020-0050-2500X075-HC116	31152934
2,00	0,5	30	4	75	3	1,9	2	MCR111-020-0050-3000X075-HC116	31152935
3,00	0,2	10	6	57	3	2,9	2	MCR111-030-0020-1000X057-HC116	31152936
3,00	0,2	15	6	57	3	2,9	2	MCR111-030-0020-1500X057-HC116	31152937
3,00	0,2	20	6	57	3	2,9	2	MCR111-030-0020-2000X057-HC116	31152938
3,00	0,2	25	6	75	3	2,9	2	MCR111-030-0020-2500X075-HC116	31152939
3,00	0,2	30	6	75	3	2,9	2	MCR111-030-0020-3000X075-HC116	31152940
3,00	0,2	45	6	75	3	2,9	2	MCR111-030-0020-4500X075-HC116	31152941
3,00	0,3	10	6	57	3	2,9	2	MCR111-030-0030-1000X057-HC116	31152942
3,00	0,3	30	6	75	3	2,9	2	MCR111-030-0030-3000X075-HC116	31152943
3,00	0,3	45	6	75	3	2,9	2	MCR111-030-0030-4500X075-HC116	31152944
3,00	0,5	10	6	57	3	2,9	2	MCR111-030-0050-1000X057-HC116	31152945
3,00	0,5	30	6	75	3	2,9	2	MCR111-030-0050-3000X075-HC116	31152946
3,00	0,5	45	6	75	3	2,9	2	MCR111-030-0050-4500X075-HC116	31152947
4,00	0,2	10	6	57	4	3,8	2	MCR111-040-0020-1000X057-HC116	31152948
4,00	0,2	20	6	57	4	3,8	2	MCR111-040-0020-2000X057-HC116	31152949
4,00	0,2	30	6	75	4	3,8	2	MCR111-040-0020-3000X075-HC116	31152950
4,00	0,2	45	6	100	4	3,8	2	MCR111-040-0020-4500X100-HC116	31152951
4,00	0,3	10	6	57	4	3,8	2	MCR111-040-0030-1000X057-HC116	31152952
4,00	0,3	30	6	75	4	3,8	2	MCR111-040-0030-3000X075-HC116	31152953
4,00	0,3	45	6	100	4	3,8	2	MCR111-040-0030-4500X100-HC116	31152954
4,00	0,5	10	6	57	4	3,8	2	MCR111-040-0050-1000X057-HC116	31152955
4,00	0,5	30	6	75	4	3,8	2	MCR111-040-0050-3000X075-HC116	31152956
4,00	0,5	45	6	100	4	3,8	2	MCR111-040-0050-4500X100-HC116	31152957

Preferred series available from stock | OptiMill®-3D-CR-Graphite | Short cutting edge length | MCR112

1,00	0,1	5	4	50	0,8	0,95	2	MCR112-010-0010-0500X050-HC116	31180364
1,00	0,1	10	4	50	0,8	0,95	2	MCR112-010-0010-1000X050-HC116	31180365
1,00	0,1	15	4	50	0,8	0,95	2	MCR112-010-0010-1500X050-HC116	31180366
1,00	0,1	20	4	75	0,8	0,95	2	MCR112-010-0010-2000X075-HC116	31180367
2,00	0,2	10	4	50	1,6	1,9	2	MCR112-020-0020-1000X050-HC116	31180368
2,00	0,2	15	4	50	1,6	1,9	2	MCR112-020-0020-1500X050-HC116	31180369
2,00	0,2	20	4	75	1,6	1,9	2	MCR112-020-0020-2000X075-HC116	31180380
2,00	0,2	25	4	75	1,6	1,9	2	MCR112-020-0020-2500X075-HC116	31180381
2,00	0,2	30	4	75	1,6	1,9	2	MCR112-020-0020-3000X075-HC116	31180382

Dimensions in mm.

For cutting data recommendations, see end of chapter.

Special designs and other coatings available upon request.

OptiMill®-3D-CR-Graphite

Corner radius milling cutter, design with neck, z=3
MCR113/MCR114

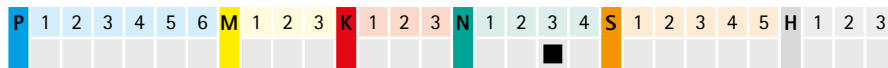
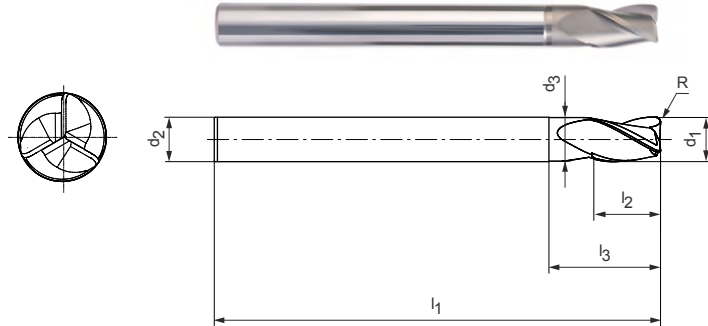

Design:

Diameter of milling cutter: 3.00 - 12.00 mm
Cutting material: HC116
Number of cutting edges: 3
Helix angle: 30°
Radial contour tolerance: ±0.01
Special features: Diamond coating
Radial contour tolerance: ±0.005 if $d_1 \leq 6$ m
±0.01 if $d_1 > 6$ m

Application:

Suitable for machining of graphite electrodes.
Mainly used for pre-finishing and roughing.

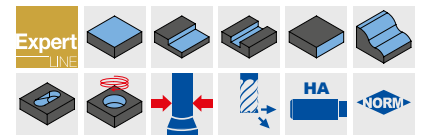

Preferred series available from stock | Normal cutting edge length | MCR113

Dimensions							z	Specification	Order no.
d ₁	R	l ₃	d ₂ h5	l ₁	l ₂	d ₃			
3,00	0,3	10	4	50	4,5	2,9	3	MCR113-030-0030-1000D050-HC116	31152958
3,00	0,3	15	4	50	4,5	2,9	3	MCR113-030-0030-1500D050-HC116	31152959
3,00	0,3	20	4	75	4,5	2,9	3	MCR113-030-0030-2000D075-HC116	31152960
3,00	0,3	25	4	75	4,5	2,9	3	MCR113-030-0030-2500D075-HC116	31152961
3,00	0,3	30	4	75	4,5	2,9	3	MCR113-030-0030-3000D075-HC116	31152962
4,00	0,3	15	4	50	6	3,8	3	MCR113-040-0030-1500D050-HC116	31152963
4,00	0,3	20	4	75	6	3,8	3	MCR113-040-0030-2000D075-HC116	31152964
4,00	0,3	25	4	75	6	3,8	3	MCR113-040-0030-2500D075-HC116	31152965
4,00	0,3	45	4	100	6	3,8	3	MCR113-040-0030-4500D100-HC116	31152966
4,00	1	15	4	50	6	3,8	3	MCR113-040-0100-1500D050-HC116	31152967
4,00	1	20	4	75	6	3,8	3	MCR113-040-0100-2000D075-HC116	31152968
4,00	1	25	4	75	6	3,8	3	MCR113-040-0100-2500D075-HC116	31152969
4,00	1	45	4	100	6	3,8	3	MCR113-040-0100-4500D100-HC116	31152970
6,00	0,3	15	6	57	9	5,8	3	MCR113-060-0030-1500D057-HC116	31152971
6,00	0,3	20	6	75	9	5,8	3	MCR113-060-0030-2000D075-HC116	31152972
6,00	0,3	25	6	75	9	5,8	3	MCR113-060-0030-2500D075-HC116	31152973
6,00	0,3	30	6	75	9	5,8	3	MCR113-060-0030-3000D075-HC116	31152974
6,00	0,3	45	6	100	9	5,8	3	MCR113-060-0030-4500D100-HC116	31152975
6,00	0,3	60	6	150	9	5,8	3	MCR113-060-0030-6000D150-HC116	31152976
6,00	1	20	6	75	9	5,8	3	MCR113-060-0100-2000D075-HC116	31152977
6,00	1	25	6	75	9	5,8	3	MCR113-060-0100-2500D075-HC116	31152978
6,00	1	30	6	75	9	5,8	3	MCR113-060-0100-3000D075-HC116	31152979
6,00	1	45	6	100	9	5,8	3	MCR113-060-0100-4500D100-HC116	31152980
6,00	1	60	6	150	9	5,8	3	MCR113-060-0100-6000D150-HC116	31152981
8,00	0,5	20	8	63	12	7,8	3	MCR113-080-0050-2000D063-HC116	31152982
8,00	0,5	45	8	100	12	7,8	3	MCR113-080-0050-4500D100-HC116	31152983
8,00	0,5	60	8	150	12	7,8	3	MCR113-080-0050-6000D150-HC116	31152984
8,00	1	20	8	63	12	7,8	3	MCR113-080-0100-2000D063-HC116	31152985
8,00	1	45	8	100	12	7,8	3	MCR113-080-0100-4500D100-HC116	31152986
8,00	1	60	8	150	12	7,8	3	MCR113-080-0100-6000D150-HC116	31152987
10,00	0,5	45	10	100	15	9,8	3	MCR113-100-0050-4500D100-HC116	31152989
10,00	0,5	60	10	150	15	9,8	3	MCR113-100-0050-6000D150-HC116	31152990
10,00	1	25	10	100	15	9,8	3	MCR113-100-0100-2500D100-HC116	31152991
10,00	1	45	10	100	15	9,8	3	MCR113-100-0100-4500D100-HC116	31152992
10,00	1	60	10	150	15	9,8	3	MCR113-100-0100-6000D150-HC116	31152993

OptiMill®-3D-CR-Graphite | Normal cutting edge length | MCR113 | Corner radius milling cutter, design with neck, z=3

Dimensions							z	Specification	Order no.
d ₁	R	l ₃	d ₂	l ₁	l ₂	d ₃			
12,00	0,5	25	12	83	18	11,8	3	MCR113-120-0050-2500D083-HC116	31152994
12,00	0,5	45	12	100	18	11,8	3	MCR113-120-0050-4500D100-HC116	31152995
12,00	1	25	12	83	18	11,8	3	MCR113-120-0100-2500D083-HC116	31152997
12,00	1	45	12	100	18	11,8	3	MCR113-120-0100-4500D100-HC116	31152998
12,00	1	60	12	150	18	11,8	3	MCR113-120-0100-6000D150-HC116	31152999

Preferred series available from stock | OptiMill®-3D-CR-Graphite | Short cutting edge length | MCR114

3,00	0,5	10	4	50	2,4	2,9	3	MCR114-030-0050-1000D050-HC116	31153000
3,00	0,5	15	4	50	2,4	2,9	3	MCR114-030-0050-1500D050-HC116	31153001
3,00	0,5	20	4	75	2,4	2,9	3	MCR114-030-0050-2000D075-HC116	31153002
3,00	0,5	25	4	75	2,4	2,9	3	MCR114-030-0050-2500D075-HC116	31153003
3,00	0,5	30	4	75	2,4	2,9	3	MCR114-030-0050-3000D075-HC116	31153004
4,00	0,5	10	4	50	3,2	3,8	3	MCR114-040-0050-1000D050-HC116	31153005
4,00	0,5	20	4	75	3,2	3,8	3	MCR114-040-0050-2000D075-HC116	31153006
4,00	0,5	25	4	75	3,2	3,8	3	MCR114-040-0050-2500D075-HC116	31153007
4,00	0,5	45	4	100	3,2	3,8	3	MCR114-040-0050-4500D100-HC116	31153008
5,00	0,3	10	6	57	3,5	4,8	3	MCR114-050-0030-1000D057-HC116	31153009
5,00	0,3	20	6	75	3,5	4,8	3	MCR114-050-0030-2000D075-HC116	31153010
5,00	0,3	45	6	100	3,5	4,8	3	MCR114-050-0030-4500D100-HC116	31153011
6,00	0,5	10	6	57	4,8	5,8	3	MCR114-060-0050-1000D057-HC116	31153012
6,00	0,5	20	6	75	4,8	5,8	3	MCR114-060-0050-2000D075-HC116	31153013
6,00	0,5	30	6	75	4,8	5,8	3	MCR114-060-0050-3000D075-HC116	31153014
6,00	0,5	45	6	100	4,8	5,8	3	MCR114-060-0050-4500D100-HC116	31153015
6,00	0,5	60	6	150	4,8	5,8	3	MCR114-060-0050-6000D150-HC116	31153016
8,00	0,5	20	8	63	6,4	7,8	3	MCR114-080-0050-2000D063-HC116	31153017
8,00	0,5	45	8	100	6,4	7,8	3	MCR114-080-0050-4500D100-HC116	31153018
8,00	0,5	60	8	150	6,4	7,8	3	MCR114-080-0050-6000D150-HC116	31153019

Dimensions in mm.

For cutting data recommendations, see end of chapter.

Special designs and other coatings available upon request.

OptiMill®-3D-CR-Graphite

Corner radius milling cutter, design with neck, z=4
MCR115/MCR116

Design:

Diameter of milling cutter: 4.00 - 12.00 mm
Cutting material: HC116
Number of cutting edges: 4
Helix angle: 30°
Radial contour tolerance: ±0.005 if $d_1 \leq 6$ mm
±0.01 if $d_1 > 6$ m
Special features: Diamond coating

Application:

Suitable for machining of graphite electrodes.
Mainly used for pre-finishing and roughing.

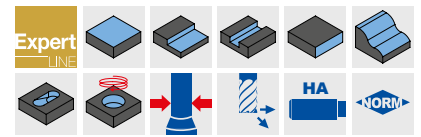
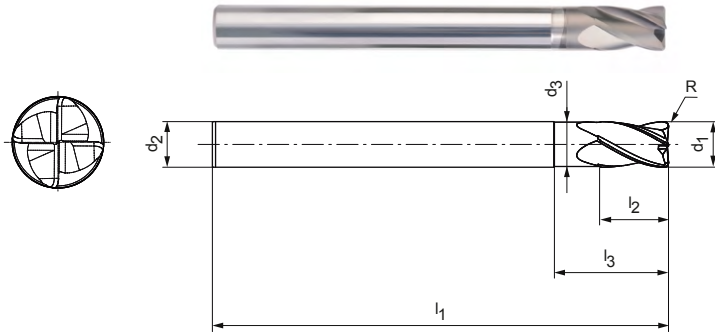

Preferred series available from stock | Normal cutting edge length | MCR115

Dimensions							z	Specification	Order no.
d ₁	R	l ₃	d ₂ h5	l ₁	l ₂	d ₃			
4,00	0,2	25	4	75	6	3,8	4	MCR115-040-0020-2500X075-HC116	31153020
4,00	1	25	4	75	6	3,8	4	MCR115-040-0100-2500X075-HC116	31153021
6,00	0,5	30	6	75	9	5,8	4	MCR115-060-0050-3000X075-HC116	31153022
6,00	0,5	45	6	100	9	5,8	4	MCR115-060-0050-4500X100-HC116	31153023
6,00	1	30	6	75	9	5,8	4	MCR115-060-0100-3000X075-HC116	31153024
6,00	1	45	6	100	9	5,8	4	MCR115-060-0100-4500X100-HC116	31153025
8,00	0,5	20	8	63	12	7,8	4	MCR115-080-0050-2000X063-HC116	31153026
8,00	0,5	45	8	100	12	7,8	4	MCR115-080-0050-4500X100-HC116	31153027
8,00	0,5	60	8	150	12	7,8	4	MCR115-080-0050-6000X150-HC116	31153028
8,00	1	20	8	63	12	7,8	4	MCR115-080-0100-2000X063-HC116	31153029
8,00	1	45	8	100	12	7,8	4	MCR115-080-0100-4500X100-HC116	31153030
8,00	1	60	8	150	12	7,8	4	MCR115-080-0100-6000X150-HC116	31153031
10,00	0,5	30	10	100	15	9,8	4	MCR115-100-0050-3000X100-HC116	31153032
10,00	0,5	60	10	150	15	9,8	4	MCR115-100-0050-6000X150-HC116	31153033
10,00	1	30	10	100	15	9,8	4	MCR115-100-0100-3000X100-HC116	31153034
10,00	1	60	10	150	15	9,8	4	MCR115-100-0100-6000X150-HC116	31153035
12,00	0,5	25	12	83	18	11,8	4	MCR115-120-0050-2500X083-HC116	31153036
12,00	0,5	45	12	100	18	11,8	4	MCR115-120-0050-4500X100-HC116	31153037
12,00	0,5	60	12	150	18	11,8	4	MCR115-120-0050-6000X150-HC116	31153038
12,00	1	25	12	83	18	11,8	4	MCR115-120-0100-2500X083-HC116	31153039
12,00	1	45	12	100	18	11,8	4	MCR115-120-0100-4500X100-HC116	31153040

Preferred series available from stock | Short cutting edge length | MCR116

4,00	0,5	25	4	75	3,2	3,8	4	MCR116-040-0050-2500X075-HC116	31153041
6,00	0,5	30	6	75	4,8	5,8	4	MCR116-060-0050-3000X075-HC116	31153042
6,00	0,5	45	6	100	4,8	5,8	4	MCR116-060-0050-4500X100-HC116	31153043
8,00	0,5	45	8	100	6,4	7,8	4	MCR116-080-0050-4500X100-HC116	31153044
8,00	0,5	60	8	150	6,4	7,8	4	MCR116-080-0050-6000X150-HC116	31153045
10,00	0,5	30	10	100	8	9,8	4	MCR116-100-0050-3000X100-HC116	31153046
10,00	0,5	60	10	150	8	9,8	4	MCR116-100-0050-6000X150-HC116	31153047

Dimensions in mm.

For cutting data recommendations, see end of chapter.

Special designs and other coatings available upon request.

OptiMill®-Diamond-Torus

Corner radius milling cutter, long design with neck, includes internal cooling
SHM551

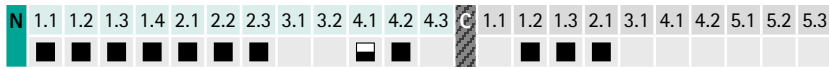
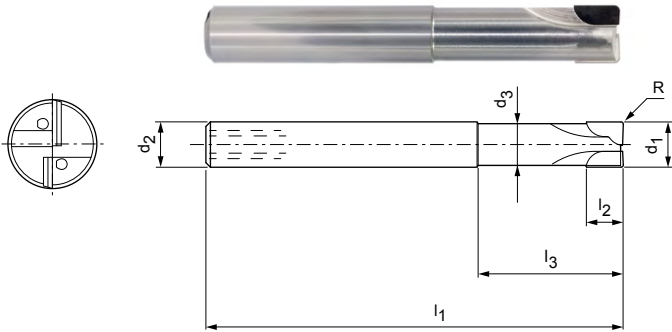

Design:

- Diameter of milling cutter: 3.00 - 10.00 mm
- Cutting material: PU611
- Number of cutting edges: 2
- Axis angle: 0°
- Special features: PCD cutting edges for a long tool life

Application:

Preferred for trimming and pocket milling, with defined corner radius. Also suitable for roughing.
Process alternative: Milling instead of drilling, thanks to a blade above centre.

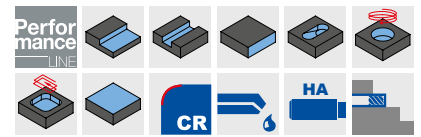

Preferred series in stock

Dimensions							z	Specification	Order no.
d ₁ e8	d ₂ h6	d ₃	l ₁	l ₂	l ₃	R			
3,00	6	2,8	50	2,5	14	0,3	2	SHM551-0300AZ02R-R0030HA-PU611	31348248
4,00	6	3,8	50	2,5	14	0,5	2	SHM551-0400AZ02R-R0050HA-PU611	31348249
5,00	6	4,6	54	3	18	0,5	2	SHM551-0500AZ02R-R0050HA-PU611	31348250
6,00	6	5,5	57	6	21	0,5	2	SHM551-0600BZ02R-R0050HA-PU611	31348251
6,00	6	5,5	57	6	21	1	2	SHM551-0600BZ02R-R0100HA-PU611	31348252
8,00	8	7,4	63	7	27	0,5	2	SHM551-0800BZ02R-R0050HA-PU611	31348253
10,00	10	9,2	72	8	32	0,5	2	SHM551-1000BZ02R-R0050HA-PU611	31348254
10,00	10	9,2	72	8	32	1	2	SHM551-1000BZ02R-R0100HA-PU611	31348255

Dimensions in mm.

For cutting data recommendations, see end of chapter.

Special designs available upon request.

OptiMill®-3D-CR-Alu

Corner radius milling cutter, z=2
MCR119

Design:

Diameter of milling cutter: 2.00 - 4.00 mm
Cutting material: HP807
Number of cutting edges: 2
Helix angle: 30°
Radial contour tolerance: ±0.01

Application:

Suitable for machining of high-strength aluminium alloys.

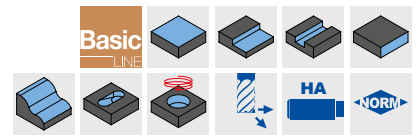
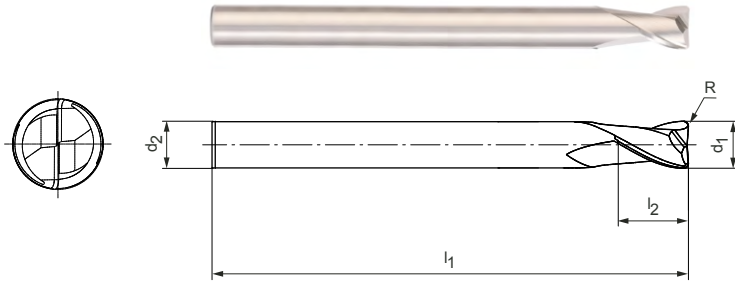

Preferred series in stock

Dimensions					z	Specification	Order no.
d ₁	R	d ₂ h5	l ₁	l ₂			
2,00	0,2	4	50	2	2	MCR119-020-0020-X050-HP807	31153205
2,00	0,5	4	50	2	2	MCR119-020-0050-X050-HP807	31153206
3,00	0,2	4	50	3	2	MCR119-030-0020-X050-HP807	31153207
3,00	0,5	4	50	3	2	MCR119-030-0050-X050-HP807	31153208
4,00	0,2	4	50	4	2	MCR119-040-0020-X050-HP807	31153209
4,00	0,5	4	50	4	2	MCR119-040-0050-X050-HP807	31153210

Dimensions in mm.

For cutting data recommendations, see end of chapter.

Special designs and other coatings available upon request.

OptiMill®-3D-CR-Alu

Corner radius milling cutter, design with neck, z=2
MCR120

Design:

Diameter of milling cutter: 2.00 - 20.00 mm
Cutting material: HP807
Number of cutting edges: 2
Helix angle: 30°
Radial contour tolerance: ±0.01

Application:

Suitable for machining of high-strength aluminium alloys.

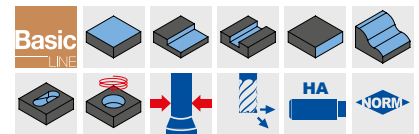
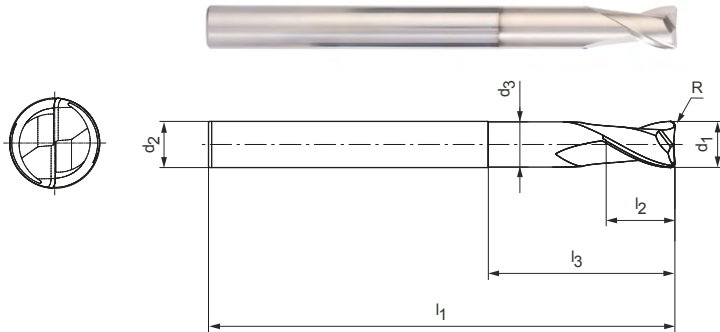

Preferred series in stock

Dimensions							z	Specification	Order no.
d ₁	R	l ₃	d ₂ h5	l ₁	l ₂	d ₃			
2,00	0,2	10	4	50	2	1,9	2	MCR120-020-0020-1000X050-HP807	31153211
2,00	0,5	10	4	50	2	1,9	2	MCR120-020-0050-1000X050-HP807	31153212
3,00	0,2	12	4	50	3	2,9	2	MCR120-030-0020-1200X050-HP807	31153213
3,00	0,5	12	4	50	3	2,9	2	MCR120-030-0050-1200X050-HP807	31153214
4,00	0,2	15	4	50	4	3,8	2	MCR120-040-0020-1500X050-HP807	31153215
4,00	0,5	15	4	50	4	3,8	2	MCR120-040-0050-1500X050-HP807	31153216
5,00	0,2	21	6	57	5	4,8	2	MCR120-050-0020-2100X057-HP807	31153217
5,00	0,5	21	6	57	5	4,8	2	MCR120-050-0050-2100X057-HP807	31153218
6,00	0,2	21	6	57	6	5,8	2	MCR120-060-0020-2100X057-HP807	31153219
6,00	0,5	21	6	57	6	5,8	2	MCR120-060-0050-2100X057-HP807	31153220
6,00	1	21	6	57	6	5,8	2	MCR120-060-0100-2100X057-HP807	31153221
6,00	1	30	6	75	6	5,8	2	MCR120-060-0100-3000X075-HP807	31153222
8,00	0,5	27	8	63	8	7,8	2	MCR120-080-0050-2700X063-HP807	31153223
8,00	1	30	8	63	8	7,8	2	MCR120-080-0100-3000X063-HP807	31153224
8,00	1	50	8	90	8	7,8	2	MCR120-080-0100-5000X090-HP807	31153225
10,00	0,5	32	10	72	10	9,8	2	MCR120-100-0050-3200X072-HP807	31153227
10,00	1	32	10	72	10	9,8	2	MCR120-100-0100-3200X072-HP807	31153228
10,00	1	40	10	100	10	9,8	2	MCR120-100-0100-4000X100-HP807	31153229
10,00	1	60	10	100	10	9,8	2	MCR120-100-0100-6000X100-HP807	31153230
10,00	1,5	32	10	72	10	9,8	2	MCR120-100-0150-3200X072-HP807	31153231
12,00	0,5	38	12	83	12	11,8	2	MCR120-120-0050-3800X083-HP807	31153233
12,00	1,5	38	12	83	12	11,8	2	MCR120-120-0150-3800X083-HP807	31153234
12,00	1,5	60	12	110	12	11,8	2	MCR120-120-0150-6000X110-HP807	31153235
12,00	1,5	80	12	110	12	11,8	2	MCR120-120-0150-8000X110-HP807	31153236
16,00	2	44	16	92	16	15,8	2	MCR120-160-0200-4400X092-HP807	31153239
20,00	2	54	20	104	20	19,8	2	MCR120-200-0200-5400X104-HP807	31153241

Available on request

16,00	1,5	50	16	92	16	15,8	2	MCR120-160-0150-5000X092-HP807	31153237
16,00	1,5	100	16	150	16	15,8	2	MCR120-160-0150-1000X150-HP807	31153238
20,00	1,5	100	20	150	20	19,8	2	MCR120-200-0150-1000X150-HP807	31153240

Dimensions in mm.

For cutting data recommendations, see end of chapter.

Special designs and other coatings available upon request.

OptiMill®-3D-CR-Copper

Corner radius milling cutter, z=2
MCR117

Design:

Diameter of milling cutter: 1.00 - 20.00 mm
Cutting material: HP804/HU318
Number of cutting edges: 2
Helix angle: 30°
Radial contour tolerance: ±0.01

Application:

Special geometry for machining of copper electrodes and tough non-ferrous alloys.

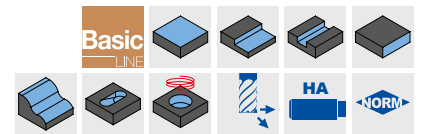
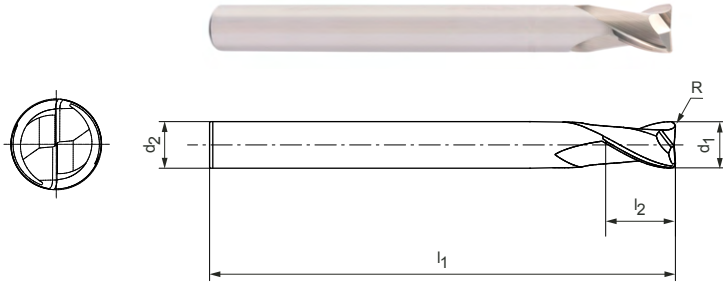

Preferred series in stock

Dimensions					z	Specification	Order no.
d ₁	R	d ₂ h5	l ₁	l ₂			
1,00	0,2	4	50	1	2	MCR117-010-0020-X050-HU318	31153074
1,50	0,2	4	50	1,5	2	MCR117-015-0020-X050-HU318	31153075
2,00	0,2	4	50	2	2	MCR117-020-0020-X050-HP804	31153076
2,00	0,5	4	50	2	2	MCR117-020-0050-X050-HP804	31153077
3,00	0,2	4	50	3	2	MCR117-030-0020-X050-HP804	31153078
3,00	0,5	4	50	3	2	MCR117-030-0050-X050-HP804	31153079
4,00	0,2	4	50	4	2	MCR117-040-0020-X050-HP804	31153080
4,00	0,5	4	50	4	2	MCR117-040-0050-X050-HP804	31153081
5,00	0,2	6	57	5	2	MCR117-050-0020-X057-HP804	31153082
5,00	0,5	6	57	5	2	MCR117-050-0050-X057-HP804	31153083
6,00	0,5	6	57	6	2	MCR117-060-0050-X057-HP804	31153084
6,00	0,7	6	57	6	2	MCR117-060-0070-X057-HP804	31153085
6,00	1	6	57	6	2	MCR117-060-0100-X057-HP804	31153086
8,00	0,5	8	63	8	2	MCR117-080-0050-X063-HP804	31153087
8,00	0,7	8	63	8	2	MCR117-080-0070-X063-HP804	31153088
8,00	1	8	63	8	2	MCR117-080-0100-X063-HP804	31153089
10,00	0,7	10	72	10	2	MCR117-100-0070-X072-HP804	31153091
10,00	1	10	72	10	2	MCR117-100-0100-X072-HP804	31153090
12,00	0,7	12	83	12	2	MCR117-120-0070-X083-HP804	31153092
12,00	1,5	12	83	12	2	MCR117-120-0150-X083-HP804	31153093
16,00	0,7	16	92	16	2	MCR117-160-0070-X092-HP804	31153094
20,00	0,7	20	104	20	2	MCR117-200-0070-X104-HP804	31153095

Dimensions in mm.

For cutting data recommendations, see end of chapter.

Special designs and other coatings available upon request.

OptiMill®-3D-CR-Copper

Corner radius milling cutter, design with neck, z=2
MCR118

Design:

Diameter of milling cutter: 1.00 - 20.00 mm
Cutting material: HP804/HU318
Number of cutting edges: 2
Helix angle: 30°
Radial contour tolerance: ±0.01

Application:

Special geometry for machining of copper electrodes and tough non-ferrous alloys.

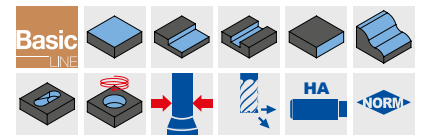
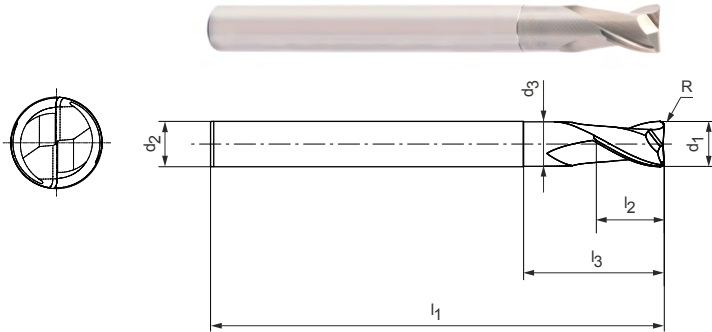

Preferred series in stock

Dimensions							z	Specification	Order no.
d ₁	R	l ₃	d ₂ h5	l ₁	l ₂	d ₃			
1,00	0,2	10	4	50	1	0,95	2	MCR118-010-0020-1000X050-HU318	31153096
1,50	0,2	10	4	50	1,5	1,4	2	MCR118-015-0020-1000X050-HU318	31153097
2,00	0,2	10	4	50	2	1,9	2	MCR118-020-0020-1000X050-HP804	31153098
2,00	0,5	10	4	50	2	1,9	2	MCR118-020-0050-1000X050-HP804	31153099
3,00	0,2	12	4	50	3	2,9	2	MCR118-030-0020-1200X050-HP804	31153100
3,00	0,5	12	4	50	3	2,9	2	MCR118-030-0050-1200X050-HP804	31153101
4,00	0,2	15	4	50	4	3,8	2	MCR118-040-0020-1500X050-HP804	31153102
4,00	0,5	15	4	50	4	3,8	2	MCR118-040-0050-1500X050-HP804	31153103
5,00	0,2	21	6	57	5	4,8	2	MCR118-050-0020-2100X057-HP804	31153104
5,00	0,5	21	6	57	5	4,8	2	MCR118-050-0050-2100X057-HP804	31153105
6,00	0,5	21	6	57	6	5,8	2	MCR118-060-0050-2100X057-HP804	31153106
6,00	0,7	21	6	57	6	5,8	2	MCR118-060-0070-2100X057-HP804	31153107
6,00	1	21	6	57	6	5,8	2	MCR118-060-0100-2100X057-HP804	31153108
8,00	0,5	27	8	63	8	7,8	2	MCR118-080-0050-0200X063-HP804	31153109
8,00	0,7	27	8	63	8	7,8	2	MCR118-080-0070-2700X063-HP804	31153110
8,00	1	27	8	63	8	7,8	2	MCR118-080-0100-2700X063-HP804	31153111
10,00	0,7	32	10	72	10	9,8	2	MCR118-100-0070-3200X072-HP804	31153112
10,00	1	32	10	72	10	9,8	2	MCR118-100-0100-3200X072-HP804	31153113
12,00	0,7	38	12	83	12	11,8	2	MCR118-120-0070-3800X083-HP804	31153114
12,00	1,5	38	12	83	12	11,8	2	MCR118-120-0150-3800X083-HP804	31153115
16,00	0,7	44	16	92	16	15,8	2	MCR118-160-0070-4400X092-HP804	31153116
20,00	0,7	54	20	104	20	19,8	2	MCR118-200-0070-5400X104-HP804	31153117

Dimensions in mm.

For cutting data recommendations, see end of chapter.

Special designs and other coatings available upon request.

Cutting data recommendations for corner radius milling cutters

Feed and cutting speed

OptiMill-3D-CR | MCR100, 101, 102, 103, 104, 105

MMG*	Workpiece material		Strength/hardness [N/mm ²] [HRC]	Cooling			
				Dry	Air/MQL	KSS	
P	P1	P1.1	Structural, machining, case hardened and tempering steels, unalloyed	< 700	✓	✓	✓
		P1.2	Structural, machining, case hardened and tempering steels, unalloyed	< 1,200	✓	✓	✓
	P2	P2.1	Nitriding, hardening and tempering steels, alloyed	< 900	✓	✓	✓
		P2.2	Nitriding, hardening and tempering steels, alloyed	< 1,400	✓	✓	✓
	P3	P3.1	Tool, bearing, spring and high-speed steels**	< 800	✓	✓	✓
		P3.2	Tool, bearing, spring and high-speed steels**	< 1,000	✓	✓	✓
		P3.3	Tool, bearing, spring and high-speed steels**	< 1,500	✓	✓	✓
	P4	P4.1	Stainless steels, ferritic and martensitic			✓	✓
	P5	P5.1	Cast steel			✓	✓
	P6	P6.1	Stainless cast steels, ferritic and martensitic			✓	✓
M	M1	M1.1	Stainless steels, austenitic	< 700			✓
		M1.2	Stainless steels, ferritic/austenitic (duplex)	< 1,000			✓
	M2	M2.1	Stainless cast steel, austenitic	< 700			✓
	M3	M3.1	Stainless cast steel, ferritic/austenitic (duplex)	< 1,000			✓
K	K1	K1.1	Cast iron with lamellar graphite (grey cast iron), GJL	< 300	✓	✓	✓
		K2.1	Cast iron with spheroidal graphite, GJS	< 500	✓	✓	✓
		K2.2	Cast iron with spheroidal graphite, GJS	≤ 800	✓	✓	✓
	K2	K2.3	Cast iron with spheroidal graphite, GJS	> 800	✓	✓	✓
		K3.1	Cast iron with vermicular graphite, GJV; malleable cast iron, GJM	< 500	✓	✓	✓
	K3	K3.2	Cast iron with vermicular graphite, GJV; malleable cast iron, GJM	> 500	✓	✓	✓
H	H1	H1.1	Hardened steel / cast steel	< 44 HRC	✓	✓	
		H1.2	Hardened steel / cast steel	< 55 HRC	✓	✓	
	H2	H2.1	Hardened steel / cast steel	< 60 HRC		✓	

Working depth correction factor – k_{AT}

AT	k_{AT}		
	a_p	n	v_f
≤ 3xD	1,00	1,00	1,00
≤ 5xD	0,80	0,90	0,90
≤ 6xD	0,70	0,85	0,85
≤ 8xD	0,60	0,75	0,75
≤ 10xD	0,50	0,70	0,70
≤ 12xD	0,45***	0,65	0,65
≤ 15xD	0,40***	0,60	0,60
≤ 20xD	0,35***	0,60	0,60
≤ 25xD	0,35***	0,50	0,50
≤ 30xD	0,30***	0,50	0,50
≤ 35xD	0,30***	0,50	0,50

Cone angle correction factor – k_{KW}

φ [°]	k_{KW}		
	a_p	n	v_f
0	1,00	1,00	1,00
0,5	1,01	1,01	1,01
1	1,02	1,02	1,02
1,5	1,03	1,03	1,03
3	1,06	1,06	1,06

Note:

To determine cutting data, please observe the notes on page 548-551.

* MAPAL machining groups

** If the alloy parts Cr, Mo, Ni, V, W in total > 8%, then select the next highest MAPAL machining group.

*** Consultation with a MAPAL application engineer.

Roughing

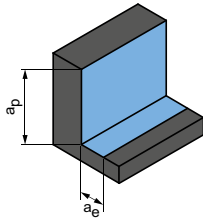

Plunge angle
1.0° - 3.0°

Next page:
Finishing (3D, face milling)

	ap [mm]	ae [mm]	vc [m/min]	fz [mm]																	
				Diameter of milling cutter [mm]																	
				0.10	0.20	0.30	0.40	0.50	0.60	0.80	1.00	1.50	1.80	2.00	2.50	3.00	4.00	5.00	6.00	8.00	10.00
0.15xD	0.45xD	250-300	0.003	0.004	0.006	0.008	0.010	0.012	0.016	0.020	0.028	0.035	0.040	0.050	0.061	0.084	0.107	0.125	0.165	0.200	0.235
0.15xD	0.45xD	240-280	0.003	0.004	0.005	0.007	0.009	0.011	0.014	0.018	0.025	0.031	0.035	0.044	0.054	0.074	0.094	0.110	0.145	0.176	0.207
0.15xD	0.45xD	250-300	0.003	0.004	0.006	0.008	0.010	0.012	0.016	0.020	0.028	0.035	0.040	0.050	0.061	0.084	0.107	0.125	0.165	0.200	0.235
0.15xD	0.45xD	240-280	0.003	0.004	0.005	0.007	0.009	0.011	0.014	0.018	0.025	0.031	0.035	0.044	0.054	0.074	0.094	0.110	0.145	0.176	0.207
0.15xD	0.45xD	250-300	0.003	0.004	0.006	0.008	0.010	0.011	0.015	0.019	0.027	0.033	0.038	0.048	0.058	0.080	0.102	0.119	0.157	0.190	0.223
0.15xD	0.45xD	240-280	0.003	0.004	0.005	0.007	0.009	0.011	0.014	0.018	0.025	0.031	0.035	0.044	0.054	0.074	0.094	0.110	0.145	0.176	0.207
0.15xD	0.45xD	220-260	0.002	0.003	0.004	0.006	0.007	0.009	0.012	0.015	0.020	0.026	0.029	0.037	0.045	0.061	0.078	0.091	0.120	0.146	0.172
0.15xD	0.45xD	240-280	0.003	0.004	0.006	0.008	0.010	0.012	0.016	0.020	0.028	0.035	0.040	0.050	0.061	0.084	0.107	0.125	0.165	0.200	0.235
0.15xD	0.45xD	240-280	0.003	0.004	0.005	0.007	0.009	0.011	0.014	0.018	0.025	0.031	0.035	0.044	0.054	0.074	0.094	0.110	0.145	0.176	0.207
0.15xD	0.45xD	200-250	0.002	0.003	0.004	0.006	0.007	0.009	0.012	0.015	0.020	0.026	0.029	0.037	0.045	0.061	0.078	0.091	0.120	0.146	0.172
0.1xD	0.4xD	85-110	0.003	0.004	0.005	0.007	0.009	0.011	0.014	0.018	0.025	0.031	0.035	0.044	0.054	0.074	0.094	0.110	0.145	0.176	0.207
0.1xD	0.4xD	60-85	0.002	0.003	0.004	0.006	0.007	0.009	0.012	0.015	0.020	0.026	0.029	0.037	0.045	0.061	0.078	0.091	0.120	0.146	0.172
0.1xD	0.4xD	85-110	0.003	0.004	0.005	0.007	0.009	0.011	0.014	0.018	0.025	0.031	0.035	0.044	0.054	0.074	0.094	0.110	0.145	0.176	0.207
0.1xD	0.4xD	60-85	0.002	0.003	0.004	0.006	0.007	0.009	0.012	0.015	0.020	0.026	0.029	0.037	0.045	0.061	0.078	0.091	0.120	0.146	0.172
0.15xD	0.55xD	250-300	0.004	0.005	0.007	0.010	0.012	0.014	0.019	0.024	0.034	0.042	0.048	0.060	0.073	0.101	0.128	0.150	0.198	0.240	0.282
0.15xD	0.55xD	250-300	0.003	0.004	0.006	0.008	0.010	0.012	0.016	0.020	0.028	0.035	0.040	0.050	0.061	0.084	0.107	0.125	0.165	0.200	0.235
0.15xD	0.55xD	240-280	0.003	0.004	0.006	0.008	0.010	0.012	0.016	0.020	0.028	0.035	0.040	0.050	0.061	0.084	0.107	0.125	0.165	0.200	0.235
0.15xD	0.55xD	240-280	0.003	0.004	0.005	0.007	0.009	0.011	0.014	0.018	0.025	0.031	0.035	0.044	0.054	0.074	0.094	0.110	0.145	0.176	0.207
0.15xD	0.55xD	250-300	0.002	0.003	0.004	0.006	0.007	0.009	0.012	0.015	0.020	0.026	0.029	0.037	0.045	0.061	0.078	0.091	0.120	0.146	0.172
0.15xD	0.55xD	240-280	0.002	0.002	0.004	0.005	0.006	0.007	0.010	0.012	0.017	0.022	0.025	0.031	0.038	0.052	0.066	0.078	0.102	0.124	0.146
0.06xD	0.35xD	200-240	0.002	0.003	0.004	0.006	0.007	0.009	0.012	0.015	0.020	0.026	0.029	0.037	0.045	0.061	0.078	0.091	0.120	0.146	0.172
0.05xD	0.3xD	140-200	0.002	0.002	0.004	0.005	0.006	0.007	0.010	0.012	0.017	0.021	0.024	0.030	0.037	0.050	0.064	0.075	0.099	0.120	0.141
0.025xD	0.25xD	100-140	0.001	0.002	0.002	0.003	0.004	0.005	0.006	0.008	0.011	0.014	0.016	0.020	0.024	0.034	0.043	0.050	0.066	0.080	0.094

The specified machining values are guide values.
The optimum data for the respective machining task should be determined during the test or machining.

Cutting data recommendations for corner radius milling cutters

Feed and cutting speed

OptiMill-3D-CR | MCR100, 101, 102, 103, 104, 105

MMG*	Workpiece material	Strength/hardness [N/mm ²] [HRC]	Cooling			
			Dry	Air/MQL	KSS	
P	P1.1	Structural, machining, case hardened and tempering steels, unalloyed	< 700	✓	✓	✓
	P1.2	Structural, machining, case hardened and tempering steels, unalloyed	< 1,200	✓	✓	✓
	P2.1	Nitriding, hardening and tempering steels, alloyed	< 900	✓	✓	✓
	P2.2	Nitriding, hardening and tempering steels, alloyed	< 1,400	✓	✓	✓
	P3.1	Tool, bearing, spring and high-speed steels**	< 800	✓	✓	✓
	P3.2	Tool, bearing, spring and high-speed steels**	< 1,000	✓	✓	✓
	P3.3	Tool, bearing, spring and high-speed steels**	< 1,500	✓	✓	✓
	P4.1	Stainless steels, ferritic and martensitic			✓	✓
	P5.1	Cast steel			✓	✓
	P6.1	Stainless cast steels, ferritic and martensitic			✓	✓
M	M1.1	Stainless steels, austenitic	< 700			✓
	M1.2	Stainless steels, ferritic/austenitic (duplex)	< 1,000			✓
	M2.1	Stainless cast steel, austenitic	< 700			✓
	M3.1	Stainless cast steel, ferritic/austenitic (duplex)	< 1,000			✓
K	K1.1	Cast iron with lamellar graphite (grey cast iron), GJL	< 300	✓	✓	✓
	K2.1	Cast iron with spheroidal graphite, GJS	< 500	✓	✓	✓
	K2.2	Cast iron with spheroidal graphite, GJS	≤ 800	✓	✓	✓
	K2.3	Cast iron with spheroidal graphite, GJS	> 800	✓	✓	✓
	K3.1	Cast iron with vermicular graphite, GJV; malleable cast iron, GJM	< 500	✓	✓	✓
	K3.2	Cast iron with vermicular graphite, GJV; malleable cast iron, GJM	> 500	✓	✓	✓
H	H1.1	Hardened steel / cast steel	< 44 HRC	✓	✓	
	H1.2	Hardened steel / cast steel	< 55 HRC	✓	✓	
	H2.1	Hardened steel / cast steel	< 60 HRC		✓	

Working depth correction factor – k_{AT}

AT	k_{AT}		
	a_p	n	v_f
≤ 3xD	1,00	1,00	1,00
≤ 5xD	0,80	0,90	0,90
≤ 6xD	0,70	0,85	0,85
≤ 8xD	0,60	0,75	0,75
≤ 10xD	0,50	0,70	0,70
≤ 12xD	0,45***	0,65	0,65
≤ 15xD	0,40***	0,60	0,60
≤ 20xD	0,35***	0,60	0,60
≤ 25xD	0,35***	0,50	0,50
≤ 30xD	0,30***	0,50	0,50
≤ 35xD	0,30***	0,50	0,50

Cone angle correction factor – k_{KW}

φ [°]	k_{KW}		
	a_p	n	v_f
0	1,00	1,00	1,00
0,5	1,01	1,01	1,01
1	1,02	1,02	1,02
1,5	1,03	1,03	1,03
3	1,06	1,06	1,06

Note:

To determine cutting data, please observe the notes on page 548-551.

* MAPAL machining groups

** If the alloy parts Cr, Mo, Ni, V, W in total > 8%, then select the next highest MAPAL machining group.

*** Consultation with a MAPAL application engineer.

Finishing
(3D, face milling)

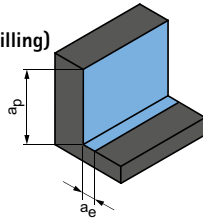

Next page:
Finishing (flat areas)

	a_p [mm]	a_e [mm]	v_c [m/min]	f_z [mm]																		
				Diameter of milling cutter [mm]																		
				0.10	0.20	0.30	0.40	0.50	0.60	0.80	1.00	1.50	1.80	2.00	2.50	3.00	4.00	5.00	6.00	8.00	10.00	12.00
0.012xD	0.022xD	280-340	0.003	0.004	0.006	0.008	0.010	0.011	0.015	0.019	0.027	0.033	0.038	0.048	0.058	0.080	0.102	0.119	0.157	0.190	0.223	
0.012xD	0.022xD	280-320	0.003	0.003	0.005	0.007	0.008	0.010	0.013	0.017	0.023	0.029	0.033	0.042	0.051	0.070	0.089	0.105	0.138	0.167	0.196	
0.012xD	0.022xD	270-320	0.003	0.004	0.006	0.008	0.010	0.011	0.015	0.019	0.027	0.033	0.038	0.048	0.058	0.080	0.102	0.119	0.157	0.190	0.223	
0.012xD	0.022xD	260-300	0.003	0.003	0.005	0.007	0.008	0.010	0.013	0.017	0.023	0.029	0.033	0.042	0.051	0.070	0.089	0.105	0.138	0.167	0.196	
0.012xD	0.022xD	280-320	0.003	0.004	0.005	0.007	0.009	0.011	0.014	0.018	0.025	0.032	0.036	0.045	0.055	0.076	0.097	0.113	0.149	0.181	0.212	
0.012xD	0.022xD	260-300	0.003	0.003	0.005	0.007	0.008	0.010	0.013	0.017	0.023	0.029	0.033	0.042	0.051	0.070	0.089	0.105	0.138	0.167	0.196	
0.012xD	0.022xD	240-280	0.002	0.003	0.004	0.006	0.007	0.008	0.011	0.014	0.019	0.024	0.028	0.035	0.042	0.058	0.074	0.087	0.114	0.139	0.163	
0.012xD	0.022xD	260-300	0.003	0.004	0.006	0.008	0.010	0.011	0.015	0.019	0.027	0.033	0.038	0.048	0.058	0.080	0.102	0.119	0.157	0.190	0.223	
0.012xD	0.022xD	260-300	0.003	0.003	0.005	0.007	0.008	0.010	0.013	0.017	0.023	0.029	0.033	0.042	0.051	0.070	0.089	0.105	0.138	0.167	0.196	
0.012xD	0.022xD	220-270	0.002	0.003	0.004	0.006	0.007	0.008	0.011	0.014	0.019	0.024	0.028	0.035	0.042	0.058	0.074	0.087	0.114	0.139	0.163	
0.013xD	0.023xD	90-120	0.003	0.003	0.005	0.007	0.008	0.010	0.013	0.017	0.023	0.029	0.033	0.042	0.051	0.070	0.089	0.105	0.138	0.167	0.196	
0.012xD	0.022xD	70-90	0.002	0.003	0.004	0.006	0.007	0.008	0.011	0.014	0.019	0.024	0.028	0.035	0.042	0.058	0.074	0.087	0.114	0.139	0.163	
0.013xD	0.023xD	90-120	0.003	0.003	0.005	0.007	0.008	0.010	0.013	0.017	0.023	0.029	0.033	0.042	0.051	0.070	0.089	0.105	0.138	0.167	0.196	
0.012xD	0.022xD	70-90	0.002	0.003	0.004	0.006	0.007	0.008	0.011	0.014	0.019	0.024	0.028	0.035	0.042	0.058	0.074	0.087	0.114	0.139	0.163	
0.012xD	0.022xD	280-340	0.003	0.004	0.006	0.008	0.010	0.011	0.015	0.019	0.027	0.033	0.038	0.048	0.058	0.080	0.102	0.119	0.157	0.190	0.223	
0.012xD	0.022xD	280-320	0.003	0.003	0.005	0.007	0.008	0.010	0.013	0.017	0.023	0.029	0.033	0.042	0.051	0.070	0.089	0.105	0.138	0.167	0.196	
0.012xD	0.022xD	270-320	0.003	0.003	0.005	0.007	0.008	0.010	0.013	0.017	0.023	0.029	0.033	0.042	0.051	0.070	0.089	0.105	0.138	0.167	0.196	
0.012xD	0.022xD	260-300	0.003	0.003	0.005	0.007	0.008	0.010	0.013	0.017	0.023	0.029	0.033	0.042	0.051	0.070	0.089	0.105	0.138	0.167	0.196	
0.012xD	0.022xD	280-320	0.002	0.003	0.004	0.006	0.007	0.008	0.011	0.014	0.019	0.024	0.028	0.035	0.042	0.058	0.074	0.087	0.114	0.139	0.163	
0.012xD	0.022xD	260-300	0.002	0.002	0.004	0.005	0.006	0.007	0.009	0.012	0.017	0.021	0.024	0.029	0.036	0.050	0.063	0.074	0.097	0.118	0.139	
0.012xD	0.022xD	220-250	0.002	0.003	0.004	0.006	0.007	0.009	0.012	0.014	0.020	0.025	0.029	0.036	0.044	0.061	0.077	0.090	0.119	0.144	0.170	
0.01xD	0.02xD	170-220	0.002	0.003	0.004	0.005	0.007	0.008	0.011	0.014	0.019	0.024	0.027	0.034	0.042	0.058	0.073	0.086	0.113	0.137	0.161	
0.01xD	0.02xD	120-170	0.001	0.002	0.003	0.004	0.005	0.006	0.008	0.010	0.013	0.017	0.019	0.024	0.029	0.040	0.051	0.060	0.079	0.096	0.113	

The specified machining values are guide values.
The optimum data for the respective machining task should be determined during the test or machining.

Cutting data recommendations for corner radius milling cutters

Feed and cutting speed

OptiMill-3D-CR | MCR100, 101, 102, 103, 104, 105

MMG*	Workpiece material		Strength/hardness [N/mm ²] [HRC]	Cooling			
				Dry	Air/MQL	KSS	
P	P1	P1.1	Structural, machining, case hardened and tempering steels, unalloyed	< 700	✓	✓	✓
		P1.2	Structural, machining, case hardened and tempering steels, unalloyed	< 1,200	✓	✓	✓
	P2	P2.1	Nitriding, hardening and tempering steels, alloyed	< 900	✓	✓	✓
		P2.2	Nitriding, hardening and tempering steels, alloyed	< 1,400	✓	✓	✓
	P3	P3.1	Tool, bearing, spring and high-speed steels**	< 800	✓	✓	✓
		P3.2	Tool, bearing, spring and high-speed steels**	< 1,000	✓	✓	✓
		P3.3	Tool, bearing, spring and high-speed steels**	< 1,500	✓	✓	✓
	P4	P4.1	Stainless steels, ferritic and martensitic			✓	✓
	P5	P5.1	Cast steel			✓	✓
	P6	P6.1	Stainless cast steels, ferritic and martensitic			✓	✓
M	M1	M1.1	Stainless steels, austenitic	< 700			✓
		M1.2	Stainless steels, ferritic/austenitic (duplex)	< 1,000			✓
	M2	M2.1	Stainless cast steel, austenitic	< 700			✓
	M3	M3.1	Stainless cast steel, ferritic/austenitic (duplex)	< 1,000			✓
K	K1	K1.1	Cast iron with lamellar graphite (grey cast iron), GJL	< 300	✓	✓	✓
		K2.1	Cast iron with spheroidal graphite, GJS	< 500	✓	✓	✓
		K2.2	Cast iron with spheroidal graphite, GJS	≤ 800	✓	✓	✓
	K2	K2.3	Cast iron with spheroidal graphite, GJS	> 800	✓	✓	✓
		K3.1	Cast iron with vermicular graphite, GJV; malleable cast iron, GJM	< 500	✓	✓	✓
	K3	K3.2	Cast iron with vermicular graphite, GJV; malleable cast iron, GJM	> 500	✓	✓	✓
H	H1	H1.1	Hardened steel / cast steel	< 44 HRC	✓	✓	
		H1.2	Hardened steel / cast steel	< 55 HRC	✓	✓	
	H2	H2.1	Hardened steel / cast steel	< 60 HRC		✓	

Working depth correction factor – k_{AT}

AT	k_{AT}		
	a_p	n	v_f
≤ 3xD	1,00	1,00	1,00
≤ 5xD	0,80	0,90	0,90
≤ 6xD	0,70	0,85	0,85
≤ 8xD	0,60	0,75	0,75
≤ 10xD	0,50	0,70	0,70
≤ 12xD	0,45***	0,65	0,65
≤ 15xD	0,40***	0,60	0,60
≤ 20xD	0,35***	0,60	0,60
≤ 25xD	0,35***	0,50	0,50
≤ 30xD	0,30***	0,50	0,50
≤ 35xD	0,30***	0,50	0,50

Cone angle correction factor – k_{KW}

φ [°]	k_{KW}		
	a_p	n	v_f
0	1,00	1,00	1,00
0,5	1,01	1,01	1,01
1	1,02	1,02	1,02
1,5	1,03	1,03	1,03
3	1,06	1,06	1,06

Note:

To determine cutting data, please observe the notes on page 548-551.

* MAPAL machining groups

** If the alloy parts Cr, Mo, Ni, V, W in total > 8%, then select the next highest MAPAL machining group.

*** Consultation with a MAPAL application engineer.

Finishing
(flat areas)

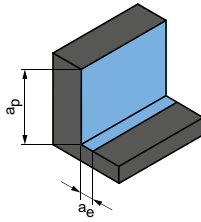

Plunge angle
0.5° - 1.0°

	a_p [mm]	a_e [mm]	v_c [m/min]	f_z [mm]																		
				Diameter of milling cutter [mm]																		
				0.10	0.20	0.30	0.40	0.50	0.60	0.80	1.00	1.50	1.80	2.00	2.50	3.00	4.00	5.00	6.00	8.00	10.00	12.00
0.012xD	0.65xD	200-250	0.003	0.004	0.006	0.008	0.010	0.011	0.015	0.019	0.027	0.033	0.038	0.048	0.058	0.080	0.102	0.119	0.157	0.190	0.223	
0.012xD	0.65xD	190-240	0.003	0.003	0.005	0.007	0.008	0.010	0.013	0.017	0.023	0.029	0.033	0.042	0.051	0.070	0.089	0.105	0.138	0.167	0.196	
0.012xD	0.65xD	200-250	0.003	0.004	0.006	0.008	0.010	0.011	0.015	0.019	0.027	0.033	0.038	0.048	0.058	0.080	0.102	0.119	0.157	0.190	0.223	
0.012xD	0.65xD	190-240	0.003	0.003	0.005	0.007	0.008	0.010	0.013	0.017	0.023	0.029	0.033	0.042	0.051	0.070	0.089	0.105	0.138	0.167	0.196	
0.012xD	0.65xD	200-250	0.003	0.004	0.005	0.007	0.009	0.011	0.014	0.018	0.025	0.032	0.036	0.045	0.055	0.076	0.097	0.113	0.149	0.181	0.212	
0.012xD	0.65xD	190-240	0.003	0.003	0.005	0.007	0.008	0.010	0.013	0.017	0.023	0.029	0.033	0.042	0.051	0.070	0.089	0.105	0.138	0.167	0.196	
0.012xD	0.65xD	180-230	0.002	0.003	0.004	0.006	0.007	0.008	0.011	0.014	0.019	0.024	0.028	0.035	0.042	0.058	0.074	0.087	0.114	0.139	0.163	
0.012xD	0.65xD	180-230	0.003	0.004	0.006	0.008	0.010	0.011	0.015	0.019	0.027	0.033	0.038	0.048	0.058	0.080	0.102	0.119	0.157	0.190	0.223	
0.012xD	0.65xD	180-230	0.003	0.003	0.005	0.007	0.008	0.010	0.013	0.017	0.023	0.029	0.033	0.042	0.051	0.070	0.089	0.105	0.138	0.167	0.196	
0.012xD	0.65xD	180-230	0.002	0.003	0.004	0.006	0.007	0.008	0.011	0.014	0.019	0.024	0.028	0.035	0.042	0.058	0.074	0.087	0.114	0.139	0.163	
0.013xD	0.4xD	90-120	0.003	0.003	0.005	0.007	0.008	0.010	0.013	0.017	0.023	0.029	0.033	0.042	0.051	0.070	0.089	0.105	0.138	0.167	0.196	
0.012xD	0.4xD	70-90	0.002	0.003	0.004	0.006	0.007	0.008	0.011	0.014	0.019	0.024	0.028	0.035	0.042	0.058	0.074	0.087	0.114	0.139	0.163	
0.013xD	0.4xD	90-120	0.003	0.003	0.005	0.007	0.008	0.010	0.013	0.017	0.023	0.029	0.033	0.042	0.051	0.070	0.089	0.105	0.138	0.167	0.196	
0.012xD	0.4xD	70-90	0.002	0.003	0.004	0.006	0.007	0.008	0.011	0.014	0.019	0.024	0.028	0.035	0.042	0.058	0.074	0.087	0.114	0.139	0.163	
0.012xD	0.65xD	200-250	0.003	0.004	0.006	0.008	0.010	0.011	0.015	0.019	0.027	0.033	0.038	0.048	0.058	0.080	0.102	0.119	0.157	0.190	0.223	
0.012xD	0.65xD	200-250	0.003	0.003	0.005	0.007	0.008	0.010	0.013	0.017	0.023	0.029	0.033	0.042	0.051	0.070	0.089	0.105	0.138	0.167	0.196	
0.012xD	0.65xD	200-250	0.003	0.003	0.005	0.007	0.008	0.010	0.013	0.017	0.023	0.029	0.033	0.042	0.051	0.070	0.089	0.105	0.138	0.167	0.196	
0.012xD	0.65xD	190-240	0.003	0.003	0.005	0.007	0.008	0.010	0.013	0.017	0.023	0.029	0.033	0.042	0.051	0.070	0.089	0.105	0.138	0.167	0.196	
0.012xD	0.65xD	200-250	0.002	0.003	0.004	0.006	0.007	0.008	0.011	0.014	0.019	0.024	0.028	0.035	0.042	0.058	0.074	0.087	0.114	0.139	0.163	
0.012xD	0.65xD	190-240	0.002	0.002	0.004	0.005	0.006	0.007	0.009	0.012	0.017	0.021	0.024	0.029	0.036	0.050	0.063	0.074	0.097	0.118	0.139	
0.012xD	0.65xD	160-200	0.002	0.003	0.004	0.006	0.007	0.009	0.012	0.014	0.020	0.025	0.029	0.036	0.044	0.061	0.077	0.090	0.119	0.144	0.170	
0.01xD	0.65xD	120-160	0.002	0.003	0.004	0.005	0.007	0.008	0.011	0.014	0.019	0.024	0.027	0.034	0.042	0.058	0.073	0.086	0.113	0.137	0.161	
0.01xD	0.65xD	80-120	0.001	0.002	0.003	0.004	0.005	0.006	0.008	0.010	0.013	0.017	0.019	0.024	0.029	0.040	0.051	0.060	0.079	0.096	0.113	

The specified machining values are guide values.

The optimum data for the respective machining task should be determined during the test or machining.

Cutting data recommendations for corner radius milling cutters

Feed and cutting speed

OptiMill-3D-CR-Hardened | MCR106, 107, 108, 109

MMG*	Workpiece material		Strength/hardness [N/mm ²] [HRC]	Cooling			
				Dry	Air/MQL	KSS	
P	P1	P1.1	Structural, machining, case hardened and tempering steels, unalloyed	< 700	✓	✓	✓
		P1.2	Structural, machining, case hardened and tempering steels, unalloyed	< 1,200	✓	✓	✓
	P2	P2.1	Nitriding, hardening and tempering steels, alloyed	< 900	✓	✓	✓
		P2.2	Nitriding, hardening and tempering steels, alloyed	< 1,400	✓	✓	✓
	P3	P3.1	Tool, bearing, spring and high-speed steels**	< 800	✓	✓	✓
		P3.2	Tool, bearing, spring and high-speed steels**	< 1,000	✓	✓	✓
		P3.3	Tool, bearing, spring and high-speed steels**	< 1,500	✓	✓	✓
	P4	P4.1	Stainless steels, ferritic and martensitic			✓	✓
	P5	P5.1	Cast steel			✓	✓
	P6	P6.1	Stainless cast steels, ferritic and martensitic			✓	✓
K	K1	K1.1	Cast iron with lamellar graphite (grey cast iron), GJL	< 300	✓	✓	✓
		K2.1	Cast iron with spheroidal graphite, GJS	< 500	✓	✓	✓
	K2	K2.2	Cast iron with spheroidal graphite, GJS	≤ 800	✓	✓	✓
		K2.3	Cast iron with spheroidal graphite, GJS	> 800	✓	✓	✓
	K3	K3.1	Cast iron with vermicular graphite, GJV; malleable cast iron, GJM	< 500	✓	✓	✓
		K3.2	Cast iron with vermicular graphite, GJV; malleable cast iron, GJM	> 500	✓	✓	✓
H	H1	H1.1	Hardened steel / cast steel	< 44 HRC	✓	✓	
		H1.2	Hardened steel / cast steel	< 55 HRC	✓	✓	
	H2	H2.1	Hardened steel / cast steel	< 60 HRC		✓	

Working depth correction factor – k_{AT}

AT	k_{AT}		
	a_p	n	v_f
≤ 3xD	1,00	1,00	1,00
≤ 5xD	0,80	0,90	0,90
≤ 6xD	0,70	0,85	0,85
≤ 8xD	0,60	0,75	0,75
≤ 10xD	0,50	0,70	0,70
≤ 12xD	0,45***	0,65	0,65
≤ 15xD	0,40***	0,60	0,60
≤ 20xD	0,35***	0,60	0,60
≤ 25xD	0,35***	0,50	0,50
≤ 30xD	0,30***	0,50	0,50
≤ 35xD	0,30***	0,50	0,50

Cone angle correction factor – k_{KW}

φ [°]	k_{KW}		
	a_p	n	v_f
0	1,00	1,00	1,00
0,5	1,01	1,01	1,01
1	1,02	1,02	1,02
1,5	1,03	1,03	1,03
3	1,06	1,06	1,06

Note:

To determine cutting data, please observe the notes on page 548-551.

* MAPAL machining groups

** If the alloy parts Cr, Mo, Ni, V, W in total > 8%, then select the next highest MAPAL machining group.

*** Consultation with a MAPAL application engineer.

Roughing

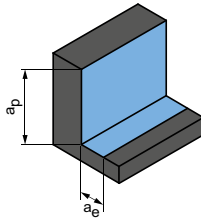

Plunge angle
1.0° - 3.0°

Next page:
Finishing (3D, face milling)

a_p [mm]	a_e [mm]	v_c [m/min]	f_z [mm]																		
			Diameter of milling cutter [mm]																		
			0.10	0.20	0.30	0.40	0.50	0.60	0.80	1.00	1.50	1.80	2.00	2.50	3.00	4.00	5.00	6.00	8.00	10.00	12.00
0.15xD	0.45xD	250-300	0.003	0.004	0.006	0.008	0.010	0.012	0.016	0.020	0.028	0.035	0.040	0.050	0.061	0.084	0.107	0.125	0.165	0.200	0.235
0.15xD	0.45xD	240-280	0.003	0.004	0.005	0.007	0.009	0.011	0.014	0.018	0.025	0.031	0.035	0.044	0.054	0.074	0.094	0.110	0.145	0.176	0.207
0.15xD	0.45xD	250-300	0.003	0.004	0.006	0.008	0.010	0.012	0.016	0.020	0.028	0.035	0.040	0.050	0.061	0.084	0.107	0.125	0.165	0.200	0.235
0.15xD	0.45xD	240-280	0.003	0.004	0.005	0.007	0.009	0.011	0.014	0.018	0.025	0.031	0.035	0.044	0.054	0.074	0.094	0.110	0.145	0.176	0.207
0.15xD	0.45xD	250-300	0.003	0.004	0.006	0.008	0.010	0.011	0.015	0.019	0.027	0.033	0.038	0.048	0.058	0.080	0.102	0.119	0.157	0.190	0.223
0.15xD	0.45xD	240-280	0.003	0.004	0.005	0.007	0.009	0.011	0.014	0.018	0.025	0.031	0.035	0.044	0.054	0.074	0.094	0.110	0.145	0.176	0.207
0.15xD	0.45xD	220-260	0.002	0.003	0.004	0.006	0.007	0.009	0.012	0.015	0.020	0.026	0.029	0.037	0.045	0.061	0.078	0.091	0.120	0.146	0.172
0.15xD	0.45xD	240-280	0.003	0.004	0.006	0.008	0.010	0.012	0.016	0.020	0.028	0.035	0.040	0.050	0.061	0.084	0.107	0.125	0.165	0.200	0.235
0.15xD	0.45xD	240-280	0.003	0.004	0.005	0.007	0.009	0.011	0.014	0.018	0.025	0.031	0.035	0.044	0.054	0.074	0.094	0.110	0.145	0.176	0.207
0.15xD	0.45xD	200-250	0.002	0.003	0.004	0.006	0.007	0.009	0.012	0.015	0.020	0.026	0.029	0.037	0.045	0.061	0.078	0.091	0.120	0.146	0.172
0.15xD	0.55xD	250-300	0.004	0.005	0.007	0.010	0.012	0.014	0.019	0.024	0.034	0.042	0.048	0.060	0.073	0.101	0.128	0.150	0.198	0.240	0.282
0.15xD	0.55xD	250-300	0.003	0.004	0.006	0.008	0.010	0.012	0.016	0.020	0.028	0.035	0.040	0.050	0.061	0.084	0.107	0.125	0.165	0.200	0.235
0.15xD	0.55xD	240-280	0.003	0.004	0.006	0.008	0.010	0.012	0.016	0.020	0.028	0.035	0.040	0.050	0.061	0.084	0.107	0.125	0.165	0.200	0.235
0.15xD	0.55xD	240-280	0.003	0.004	0.005	0.007	0.009	0.011	0.014	0.018	0.025	0.031	0.035	0.044	0.054	0.074	0.094	0.110	0.145	0.176	0.207
0.15xD	0.55xD	250-300	0.002	0.003	0.004	0.006	0.007	0.009	0.012	0.015	0.020	0.026	0.029	0.037	0.045	0.061	0.078	0.091	0.120	0.146	0.172
0.15xD	0.55xD	240-280	0.002	0.002	0.004	0.005	0.006	0.007	0.010	0.012	0.017	0.022	0.025	0.031	0.038	0.052	0.066	0.078	0.102	0.124	0.146
0.06xD	0.35xD	200-250	0.002	0.003	0.004	0.006	0.007	0.009	0.012	0.015	0.020	0.026	0.029	0.037	0.045	0.061	0.078	0.091	0.120	0.146	0.172
0.05xD	0.3xD	180-230	0.002	0.002	0.004	0.005	0.006	0.007	0.010	0.012	0.017	0.021	0.024	0.030	0.037	0.050	0.064	0.075	0.099	0.120	0.141
0.025xD	0.25xD	140-180	0.001	0.002	0.002	0.003	0.004	0.005	0.006	0.008	0.011	0.014	0.016	0.020	0.024	0.034	0.043	0.050	0.066	0.080	0.094

The specified machining values are guide values.
The optimum data for the respective machining task should be determined during the test or machining.

Cutting data recommendations for corner radius milling cutters

Feed and cutting speed

OptiMill-3D-CR-Hardened | MCR106, 107, 108, 109

MMG*	Workpiece material	Strength/hardness [N/mm ²] [HRC]	Cooling			
			Dry	Air/MQL	KSS	
P	P1.1	Structural, machining, case hardened and tempering steels, unalloyed	< 700	✓	✓	✓
	P1.2	Structural, machining, case hardened and tempering steels, unalloyed	< 1,200	✓	✓	✓
	P2.1	Nitriding, hardening and tempering steels, alloyed	< 900	✓	✓	✓
	P2.2	Nitriding, hardening and tempering steels, alloyed	< 1,400	✓	✓	✓
	P3.1	Tool, bearing, spring and high-speed steels**	< 800	✓	✓	✓
	P3.2	Tool, bearing, spring and high-speed steels**	< 1,000	✓	✓	✓
	P3.3	Tool, bearing, spring and high-speed steels**	< 1,500	✓	✓	✓
	P4.1	Stainless steels, ferritic and martensitic			✓	✓
	P5.1	Cast steel			✓	✓
	P6.1	Stainless cast steels, ferritic and martensitic			✓	✓
K	K1.1	Cast iron with lamellar graphite (grey cast iron), GJL	< 300	✓	✓	✓
	K2.1	Cast iron with spheroidal graphite, GJS	< 500	✓	✓	✓
	K2.2	Cast iron with spheroidal graphite, GJS	≤ 800	✓	✓	✓
	K2.3	Cast iron with spheroidal graphite, GJS	> 800	✓	✓	✓
	K3.1	Cast iron with vermicular graphite, GJV; malleable cast iron, GJM	< 500	✓	✓	✓
	K3.2	Cast iron with vermicular graphite, GJV; malleable cast iron, GJM	> 500	✓	✓	✓
H	H1.1	Hardened steel / cast steel	< 44 HRC	✓	✓	
	H1.2	Hardened steel / cast steel	< 55 HRC	✓	✓	
	H2.1	Hardened steel / cast steel	< 60 HRC		✓	
	H2.2	Hardened steel / cast steel	< 65 HRC		✓	
	H2.3	Hardened steel / cast steel	< 68 HRC		✓	
	H3.1	Wear-resistant cast / chill casting, GJN		✓	✓	

Working depth correction factor – k_{AT}

AT	k_{AT}		
	a_p	n	v_f
≤ 3xD	1,00	1,00	1,00
≤ 5xD	0,80	0,90	0,90
≤ 6xD	0,70	0,85	0,85
≤ 8xD	0,60	0,75	0,75
≤ 10xD	0,50	0,70	0,70
≤ 12xD	0,45***	0,65	0,65
≤ 15xD	0,40***	0,60	0,60
≤ 20xD	0,35***	0,60	0,60
≤ 25xD	0,35***	0,50	0,50
≤ 30xD	0,30***	0,50	0,50
≤ 35xD	0,30***	0,50	0,50

Cone angle correction factor – k_{KW}

φ [°]	k_{KW}		
	a_p	n	v_f
0	1,00	1,00	1,00
0,5	1,01	1,01	1,01
1	1,02	1,02	1,02
1,5	1,03	1,03	1,03
3	1,06	1,06	1,06

Note:

To determine cutting data, please observe the notes on page 548-551.

* MAPAL machining groups

** If the alloy parts Cr, Mo, Ni, V, W in total > 8%, then select the next highest MAPAL machining group.

*** Consultation with a MAPAL application engineer.

Finishing
(3D, face milling)

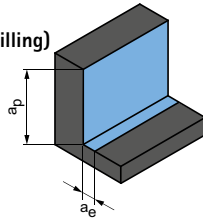

Next page:
Finishing (flat areas)

a_p [mm]	a_e [mm]	v_c [m/min]	f_z [mm]																		
			Diameter of milling cutter [mm]																		
			0.10	0.20	0.30	0.40	0.50	0.60	0.80	1.00	1.50	1.80	2.00	2.50	3.00	4.00	5.00	6.00	8.00	10.00	12.00
0.012xD	0.022xD	280-340	0.003	0.004	0.006	0.008	0.010	0.011	0.015	0.019	0.027	0.033	0.038	0.048	0.058	0.080	0.102	0.119	0.157	0.190	0.223
0.012xD	0.022xD	280-320	0.003	0.003	0.005	0.007	0.008	0.010	0.013	0.017	0.023	0.029	0.033	0.042	0.051	0.070	0.089	0.105	0.138	0.167	0.196
0.012xD	0.022xD	270-320	0.003	0.004	0.006	0.008	0.010	0.011	0.015	0.019	0.027	0.033	0.038	0.048	0.058	0.080	0.102	0.119	0.157	0.190	0.223
0.012xD	0.022xD	260-300	0.003	0.003	0.005	0.007	0.008	0.010	0.013	0.017	0.023	0.029	0.033	0.042	0.051	0.070	0.089	0.105	0.138	0.167	0.196
0.012xD	0.022xD	280-320	0.003	0.004	0.005	0.007	0.009	0.011	0.014	0.018	0.025	0.032	0.036	0.045	0.055	0.076	0.097	0.113	0.149	0.181	0.212
0.012xD	0.022xD	260-300	0.003	0.003	0.005	0.007	0.008	0.010	0.013	0.017	0.023	0.029	0.033	0.042	0.051	0.070	0.089	0.105	0.138	0.167	0.196
0.012xD	0.022xD	240-280	0.002	0.003	0.004	0.006	0.007	0.008	0.011	0.014	0.019	0.024	0.028	0.035	0.042	0.058	0.074	0.087	0.114	0.139	0.163
0.012xD	0.022xD	260-300	0.003	0.004	0.006	0.008	0.010	0.011	0.015	0.019	0.027	0.033	0.038	0.048	0.058	0.080	0.102	0.119	0.157	0.190	0.223
0.012xD	0.022xD	260-300	0.003	0.003	0.005	0.007	0.008	0.010	0.013	0.017	0.023	0.029	0.033	0.042	0.051	0.070	0.089	0.105	0.138	0.167	0.196
0.012xD	0.022xD	220-270	0.002	0.003	0.004	0.006	0.007	0.008	0.011	0.014	0.019	0.024	0.028	0.035	0.042	0.058	0.074	0.087	0.114	0.139	0.163
0.012xD	0.022xD	280-340	0.003	0.004	0.006	0.008	0.010	0.011	0.015	0.019	0.027	0.033	0.038	0.048	0.058	0.080	0.102	0.119	0.157	0.190	0.223
0.012xD	0.022xD	280-320	0.003	0.003	0.005	0.007	0.008	0.010	0.013	0.017	0.023	0.029	0.033	0.042	0.051	0.070	0.089	0.105	0.138	0.167	0.196
0.012xD	0.022xD	270-320	0.003	0.003	0.005	0.007	0.008	0.010	0.013	0.017	0.023	0.029	0.033	0.042	0.051	0.070	0.089	0.105	0.138	0.167	0.196
0.012xD	0.022xD	260-300	0.003	0.003	0.005	0.007	0.008	0.010	0.013	0.017	0.023	0.029	0.033	0.042	0.051	0.070	0.089	0.105	0.138	0.167	0.196
0.012xD	0.022xD	280-320	0.002	0.003	0.004	0.006	0.007	0.008	0.011	0.014	0.019	0.024	0.028	0.035	0.042	0.058	0.074	0.087	0.114	0.139	0.163
0.012xD	0.022xD	260-300	0.002	0.002	0.004	0.005	0.006	0.007	0.009	0.012	0.017	0.021	0.024	0.029	0.036	0.050	0.063	0.074	0.097	0.118	0.139
0.012xD	0.022xD	220-250	0.002	0.003	0.004	0.006	0.007	0.009	0.012	0.014	0.020	0.025	0.029	0.036	0.044	0.061	0.077	0.090	0.119	0.144	0.170
0.01xD	0.02xD	190-220	0.002	0.003	0.004	0.005	0.007	0.008	0.011	0.014	0.019	0.024	0.027	0.034	0.042	0.058	0.073	0.086	0.113	0.137	0.161
0.01xD	0.02xD	150-190	0.001	0.002	0.003	0.004	0.005	0.006	0.008	0.010	0.013	0.017	0.019	0.024	0.029	0.040	0.051	0.060	0.079	0.096	0.113
0.007xD	0.017xD	120-150	0.001	0.002	0.003	0.003	0.004	0.005	0.007	0.008	0.012	0.015	0.017	0.021	0.025	0.035	0.045	0.052	0.069	0.084	0.098
0.005xD	0.015xD	80-120	0.001	0.002	0.002	0.003	0.004	0.005	0.006	0.008	0.011	0.014	0.016	0.020	0.024	0.033	0.042	0.050	0.065	0.079	0.093
0.008xD	0.018xD	150-200	0.001	0.002	0.003	0.004	0.005	0.006	0.008	0.010	0.013	0.017	0.019	0.024	0.029	0.040	0.051	0.060	0.079	0.096	0.113

The specified machining values are guide values.
The optimum data for the respective machining task should be determined during the test or machining.

Cutting data recommendations for corner radius milling cutters

Feed and cutting speed

OptiMill-3D-CR-Hardened | MCR106, 107, 108, 109

MMG*	Workpiece material	Strength/hardness [N/mm ²] [HRC]	Cooling			
			Dry	Air/MQL	KSS	
P	P1.1	Structural, machining, case hardened and tempering steels, unalloyed	< 700	✓	✓	✓
	P1.2	Structural, machining, case hardened and tempering steels, unalloyed	< 1,200	✓	✓	✓
	P2.1	Nitriding, hardening and tempering steels, alloyed	< 900	✓	✓	✓
	P2.2	Nitriding, hardening and tempering steels, alloyed	< 1,400	✓	✓	✓
	P3.1	Tool, bearing, spring and high-speed steels**	< 800	✓	✓	✓
	P3.2	Tool, bearing, spring and high-speed steels**	< 1,000	✓	✓	✓
	P3.3	Tool, bearing, spring and high-speed steels**	< 1,500	✓	✓	✓
	P4.1	Stainless steels, ferritic and martensitic			✓	✓
	P5.1	Cast steel			✓	✓
	P6.1	Stainless cast steels, ferritic and martensitic			✓	✓
K	K1.1	Cast iron with lamellar graphite (grey cast iron), GJL	< 300	✓	✓	✓
	K2.1	Cast iron with spheroidal graphite, GJS	< 500	✓	✓	✓
	K2.2	Cast iron with spheroidal graphite, GJS	≤ 800	✓	✓	✓
	K2.3	Cast iron with spheroidal graphite, GJS	> 800	✓	✓	✓
	K3.1	Cast iron with vermicular graphite, GJV; malleable cast iron, GJM	< 500	✓	✓	✓
	K3.2	Cast iron with vermicular graphite, GJV; malleable cast iron, GJM	> 500	✓	✓	✓
H	H1.1	Hardened steel / cast steel	< 44 HRC	✓	✓	
	H1.2	Hardened steel / cast steel	< 55 HRC	✓	✓	
	H2.1	Hardened steel / cast steel	< 60 HRC		✓	
	H2.2	Hardened steel / cast steel	< 65 HRC		✓	
	H2.3	Hardened steel / cast steel	< 68 HRC		✓	
	H3.1	Wear-resistant cast / chill casting, GJN		✓	✓	

Working depth correction factor – k_{AT}

AT	k_{AT}		
	a_p	n	v_f
≤ 3xD	1,00	1,00	1,00
≤ 5xD	0,80	0,90	0,90
≤ 6xD	0,70	0,85	0,85
≤ 8xD	0,60	0,75	0,75
≤ 10xD	0,50	0,70	0,70
≤ 12xD	0,45***	0,65	0,65
≤ 15xD	0,40***	0,60	0,60
≤ 20xD	0,35***	0,60	0,60
≤ 25xD	0,35***	0,50	0,50
≤ 30xD	0,30***	0,50	0,50
≤ 35xD	0,30***	0,50	0,50

Cone angle correction factor – k_{KW}

φ [°]	k_{KW}		
	a_p	n	v_f
0	1,00	1,00	1,00
0,5	1,01	1,01	1,01
1	1,02	1,02	1,02
1,5	1,03	1,03	1,03
3	1,06	1,06	1,06

Note:

To determine cutting data, please observe the notes on page 548-551.

* MAPAL machining groups

** If the alloy parts Cr, Mo, Ni, V, W in total > 8%, then select the next highest MAPAL machining group.

*** Consultation with a MAPAL application engineer.

Finishing
(flat areas)

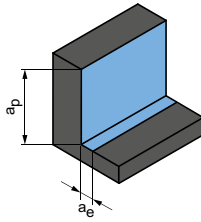

Plunge angle
0.5° - 1.0°

	a_p [mm]	a_e [mm]	v_c [m/min]	f_z [mm]																		
				Diameter of milling cutter [mm]																		
				0.10	0.20	0.30	0.40	0.50	0.60	0.80	1.00	1.50	1.80	2.00	2.50	3.00	4.00	5.00	6.00	8.00	10.00	12.00
0.012xD	0.65xD	200-250	0.003	0.004	0.006	0.008	0.010	0.011	0.015	0.019	0.027	0.033	0.038	0.048	0.058	0.080	0.102	0.119	0.157	0.190	0.223	
0.012xD	0.65xD	190-240	0.003	0.003	0.005	0.007	0.008	0.010	0.013	0.017	0.023	0.029	0.033	0.042	0.051	0.070	0.089	0.105	0.138	0.167	0.196	
0.012xD	0.65xD	200-250	0.003	0.004	0.006	0.008	0.010	0.011	0.015	0.019	0.027	0.033	0.038	0.048	0.058	0.080	0.102	0.119	0.157	0.190	0.223	
0.012xD	0.65xD	190-240	0.003	0.003	0.005	0.007	0.008	0.010	0.013	0.017	0.023	0.029	0.033	0.042	0.051	0.070	0.089	0.105	0.138	0.167	0.196	
0.012xD	0.65xD	200-250	0.003	0.004	0.005	0.007	0.009	0.011	0.014	0.018	0.025	0.032	0.036	0.045	0.055	0.076	0.097	0.113	0.149	0.181	0.212	
0.012xD	0.65xD	190-240	0.003	0.003	0.005	0.007	0.008	0.010	0.013	0.017	0.023	0.029	0.033	0.042	0.051	0.070	0.089	0.105	0.138	0.167	0.196	
0.012xD	0.65xD	180-230	0.002	0.003	0.004	0.006	0.007	0.008	0.011	0.014	0.019	0.024	0.028	0.035	0.042	0.058	0.074	0.087	0.114	0.139	0.163	
0.012xD	0.65xD	180-230	0.003	0.004	0.006	0.008	0.010	0.011	0.015	0.019	0.027	0.033	0.038	0.048	0.058	0.080	0.102	0.119	0.157	0.190	0.223	
0.012xD	0.65xD	180-230	0.003	0.003	0.005	0.007	0.008	0.010	0.013	0.017	0.023	0.029	0.033	0.042	0.051	0.070	0.089	0.105	0.138	0.167	0.196	
0.012xD	0.65xD	180-230	0.002	0.003	0.004	0.006	0.007	0.008	0.011	0.014	0.019	0.024	0.028	0.035	0.042	0.058	0.074	0.087	0.114	0.139	0.163	
0.012xD	0.65xD	200-250	0.003	0.004	0.006	0.008	0.010	0.011	0.015	0.019	0.027	0.033	0.038	0.048	0.058	0.080	0.102	0.119	0.157	0.190	0.223	
0.012xD	0.65xD	200-250	0.003	0.003	0.005	0.007	0.008	0.010	0.013	0.017	0.023	0.029	0.033	0.042	0.051	0.070	0.089	0.105	0.138	0.167	0.196	
0.012xD	0.65xD	200-250	0.003	0.003	0.005	0.007	0.008	0.010	0.013	0.017	0.023	0.029	0.033	0.042	0.051	0.070	0.089	0.105	0.138	0.167	0.196	
0.012xD	0.65xD	190-240	0.003	0.003	0.005	0.007	0.008	0.010	0.013	0.017	0.023	0.029	0.033	0.042	0.051	0.070	0.089	0.105	0.138	0.167	0.196	
0.012xD	0.65xD	200-250	0.002	0.003	0.004	0.006	0.007	0.008	0.011	0.014	0.019	0.024	0.028	0.035	0.042	0.058	0.074	0.087	0.114	0.139	0.163	
0.012xD	0.65xD	190-240	0.002	0.002	0.004	0.005	0.006	0.007	0.009	0.012	0.017	0.021	0.024	0.029	0.036	0.050	0.063	0.074	0.097	0.118	0.139	
0.012xD	0.65xD	160-200	0.002	0.003	0.004	0.006	0.007	0.009	0.012	0.014	0.020	0.025	0.029	0.036	0.044	0.061	0.077	0.090	0.119	0.144	0.170	
0.01xD	0.65xD	120-160	0.002	0.003	0.004	0.005	0.007	0.008	0.011	0.014	0.019	0.024	0.027	0.034	0.042	0.058	0.073	0.086	0.113	0.137	0.161	
0.01xD	0.65xD	80-120	0.001	0.002	0.003	0.004	0.005	0.006	0.008	0.010	0.013	0.017	0.019	0.024	0.029	0.040	0.051	0.060	0.079	0.096	0.113	
0.006xD	0.45xD	50-80	0.001	0.002	0.003	0.003	0.004	0.005	0.007	0.008	0.012	0.015	0.017	0.021	0.025	0.035	0.045	0.052	0.069	0.084	0.098	
0.005xD	0.3xD	35-60	0.001	0.002	0.002	0.003	0.004	0.005	0.006	0.008	0.011	0.014	0.016	0.020	0.024	0.033	0.042	0.050	0.065	0.079	0.093	
0.008xD	0.55xD	80-120	0.001	0.002	0.003	0.004	0.005	0.006	0.008	0.010	0.013	0.017	0.019	0.024	0.029	0.040	0.051	0.060	0.079	0.096	0.113	

The specified machining values are guide values.
The optimum data for the respective machining task should be determined during the test or machining.

Cutting data recommendations for corner radius milling cutters

Feed and cutting speed

Roughing

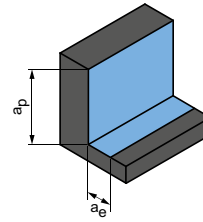

Plunge angle
1.0° - 3.0°

OptiMill-3D-CR-Hardened | MCR110

MMG*	Workpiece material	Strength/hardness [N/mm ²] [HRC]	Cooling			a _p [mm]	a _e [mm]	v _c [m/min]	f _z [mm]						
			Dry	Air/MQL	KSS				Diameter of milling cutter [mm]						
									4.00	5.00	6.00	8.00	10.00	12.00	
P	P1.1	Structural, machining, case hardened and tempering steels, unalloyed	< 700	✓	✓	✓	0.15xD	0.35xD	220-270	0.080	0.090	0.100	0.120	0.150	0.180
	P1.2	Structural, machining, case hardened and tempering steels, unalloyed	< 1,200	✓	✓	✓	0.15xD	0.35xD	210-260	0.080	0.090	0.100	0.120	0.150	0.180
	P2.1	Nitriding, hardening and tempering steels, alloyed	< 900	✓	✓	✓	0.15xD	0.35xD	220-270	0.080	0.090	0.100	0.120	0.150	0.180
	P2.2	Nitriding, hardening and tempering steels, alloyed	< 1,400	✓	✓	✓	0.15xD	0.35xD	210-260	0.070	0.080	0.090	0.110	0.130	0.160
	P3.1	Tool, bearing, spring and high-speed steels**	< 800	✓	✓	✓	0.15xD	0.35xD	220-270	0.080	0.090	0.100	0.120	0.150	0.180
	P3.2	Tool, bearing, spring and high-speed steels**	< 1,000	✓	✓	✓	0.15xD	0.35xD	200-250	0.070	0.080	0.090	0.110	0.130	0.160
	P3.3	Tool, bearing, spring and high-speed steels**	< 1,500	✓	✓	✓	0.15xD	0.35xD	200-250	0.070	0.080	0.090	0.110	0.130	0.160
	P4.1	Stainless steels, ferritic and martensitic		✓	✓		0.15xD	0.35xD	200-250	0.070	0.080	0.090	0.110	0.130	0.160
	P5.1	Cast steel		✓	✓		0.15xD	0.35xD	200-250	0.070	0.080	0.090	0.110	0.130	0.160
	P6.1	Stainless cast steels, ferritic and martensitic		✓	✓		0.15xD	0.35xD	200-250	0.070	0.080	0.090	0.110	0.130	0.160
K	K1.1	Cast iron with lamellar graphite (grey cast iron), GJL	< 300	✓	✓	✓	0.15xD	0.4xD	220-270	0.080	0.090	0.100	0.120	0.150	0.180
	K2.1	Cast iron with spheroidal graphite, GJS	< 500	✓	✓	✓	0.15xD	0.4xD	220-270	0.080	0.090	0.100	0.120	0.150	0.180
	K2.2	Cast iron with spheroidal graphite, GJS	≤ 800	✓	✓	✓	0.15xD	0.4xD	220-270	0.080	0.090	0.100	0.120	0.150	0.180
	K2.3	Cast iron with spheroidal graphite, GJS	> 800	✓	✓	✓	0.15xD	0.4xD	200-250	0.080	0.090	0.100	0.120	0.150	0.180
	K3.1	Cast iron with vermicular graphite, GJV; malleable cast iron, GJM	< 500	✓	✓	✓	0.15xD	0.4xD	220-270	0.080	0.090	0.100	0.120	0.150	0.180
	K3.2	Cast iron with vermicular graphite, GJV; malleable cast iron, GJM	> 500	✓	✓	✓	0.15xD	0.4xD	200-250	0.080	0.090	0.100	0.120	0.150	0.180
H	H1.1	Hardened steel / cast steel	< 44 HRC	✓	✓		0.06xD	0.35xD	200-250	0.060	0.080	0.090	0.110	0.130	0.160
	H1.2	Hardened steel / cast steel	< 55 HRC	✓	✓		0.05xD	0.3xD	180-230	0.050	0.070	0.080	0.095	0.110	0.140
	H2.1	Hardened steel / cast steel	< 60 HRC		✓		0.025xD	0.25xD	140-180	0.040	0.060	0.070	0.085	0.095	0.120
	H2.2	Hardened steel / cast steel	< 65 HRC		✓										
	H2.3	Hardened steel / cast steel	< 68 HRC		✓										
	H3.1	Wear-resistant cast / chill casting, GJN		✓	✓										

Working depth correction factor - k_{AT}

AT	k _{AT}		
	a _p	n	v _f
≤ 3xD	1,00	1,00	1,00
≤ 5xD	0,80	0,90	0,90
≤ 6xD	0,70	0,85	0,85
≤ 8xD	0,60	0,75	0,75
≤ 10xD	0,50	0,70	0,70
≤ 12xD	0,45***	0,65	0,65
≤ 15xD	0,40***	0,60	0,60
≤ 20xD	0,35***	0,60	0,60
≤ 25xD	0,35***	0,50	0,50
≤ 30xD	0,30***	0,50	0,50
≤ 35xD	0,30***	0,50	0,50

Cone angle correction factor - k_{KW}

φ [°]	k _{KW}		
	a _p	n	v _f
0	1,00	1,00	1,00
0,5	1,01	1,01	1,01
1	1,02	1,02	1,02
1,5	1,03	1,03	1,03
3	1,06	1,06	1,06

Note:
To determine cutting data, please observe the notes on page 548-551.

* MAPAL machining groups

** If the alloy parts Cr, Mo, Ni, V, W in total > 8%, then select the next highest MAPAL machining group.

*** Consultation with a MAPAL application engineer.

Finishing
(3D, face milling)

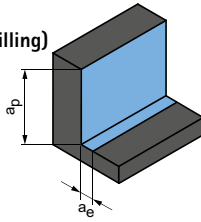

Finishing
(flat areas)

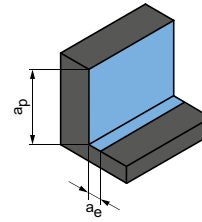

Plunge angle
0.5° - 1.0°

	a _p [mm]	a _e [mm]	v _c [m/min]	f _z [mm]						a _p [mm]	a _e [mm]	v _c [m/min]	f _z [mm]														
				Diameter of milling cutter [mm]									Diameter of milling cutter [mm]														
				4.00	5.00	6.00	8.00	10.00	12.00				4.00	5.00	6.00	8.00	10.00	12.00									
	0.012xD	0.022xD	260-320	0.050	0.060	0.080	0.090	0.110	0.130	0.012xD	0.65xD	200-250	0.050	0.060	0.080	0.090	0.110	0.130	0.012xD	0.65xD	190-240	0.050	0.060	0.080	0.090	0.110	0.130
	0.012xD	0.022xD	260-320	0.050	0.060	0.080	0.090	0.110	0.130	0.012xD	0.65xD	200-250	0.050	0.060	0.080	0.090	0.110	0.130	0.012xD	0.65xD	190-240	0.050	0.060	0.080	0.090	0.110	0.130
	0.012xD	0.022xD	250-300	0.050	0.060	0.080	0.090	0.110	0.130	0.012xD	0.65xD	200-250	0.050	0.060	0.080	0.090	0.110	0.130	0.012xD	0.65xD	190-240	0.050	0.060	0.080	0.090	0.110	0.130
	0.012xD	0.022xD	250-300	0.050	0.060	0.080	0.090	0.110	0.130	0.012xD	0.65xD	200-250	0.050	0.060	0.080	0.090	0.110	0.130	0.012xD	0.65xD	190-240	0.050	0.060	0.080	0.090	0.110	0.130
	0.012xD	0.022xD	240-300	0.050	0.060	0.080	0.090	0.110	0.130	0.012xD	0.65xD	180-230	0.050	0.060	0.080	0.090	0.110	0.130	0.012xD	0.65xD	180-230	0.050	0.060	0.080	0.090	0.110	0.130
	0.012xD	0.022xD	240-300	0.050	0.060	0.080	0.090	0.110	0.130	0.012xD	0.65xD	180-230	0.050	0.060	0.080	0.090	0.110	0.130	0.012xD	0.65xD	180-230	0.050	0.060	0.080	0.090	0.110	0.130
	0.012xD	0.022xD	240-300	0.050	0.060	0.080	0.090	0.110	0.130	0.012xD	0.65xD	180-230	0.050	0.060	0.080	0.090	0.110	0.130	0.012xD	0.65xD	180-230	0.050	0.060	0.080	0.090	0.110	0.130
	0.012xD	0.022xD	240-300	0.050	0.060	0.080	0.090	0.110	0.130	0.012xD	0.65xD	180-230	0.050	0.060	0.080	0.090	0.110	0.130	0.012xD	0.65xD	180-230	0.050	0.060	0.080	0.090	0.110	0.130
	0.012xD	0.022xD	260-320	0.050	0.060	0.080	0.090	0.110	0.130	0.012xD	0.65xD	200-250	0.050	0.060	0.080	0.090	0.110	0.130	0.012xD	0.65xD	200-250	0.050	0.060	0.080	0.090	0.110	0.130
	0.012xD	0.022xD	260-320	0.050	0.060	0.080	0.090	0.110	0.130	0.012xD	0.65xD	220-250	0.050	0.060	0.080	0.090	0.110	0.130	0.012xD	0.65xD	220-250	0.050	0.060	0.080	0.090	0.110	0.130
	0.012xD	0.022xD	260-320	0.050	0.060	0.080	0.090	0.110	0.130	0.012xD	0.65xD	200-250	0.050	0.060	0.080	0.090	0.110	0.130	0.012xD	0.65xD	200-250	0.050	0.060	0.080	0.090	0.110	0.130
	0.012xD	0.022xD	250-300	0.050	0.060	0.080	0.090	0.110	0.130	0.012xD	0.65xD	190-240	0.050	0.060	0.080	0.090	0.110	0.130	0.012xD	0.65xD	190-240	0.050	0.060	0.080	0.090	0.110	0.130
	0.012xD	0.022xD	260-320	0.050	0.060	0.080	0.090	0.110	0.130	0.012xD	0.65xD	200-250	0.050	0.060	0.080	0.090	0.110	0.130	0.012xD	0.65xD	200-250	0.050	0.060	0.080	0.090	0.110	0.130
	0.012xD	0.022xD	240-300	0.050	0.060	0.080	0.090	0.110	0.130	0.012xD	0.65xD	190-240	0.050	0.060	0.080	0.090	0.110	0.130	0.012xD	0.65xD	190-240	0.050	0.060	0.080	0.090	0.110	0.130
	0.012xD	0.022xD	240-300	0.050	0.060	0.080	0.090	0.110	0.130	0.012xD	0.65xD	180-230	0.050	0.060	0.080	0.090	0.110	0.130	0.012xD	0.65xD	180-230	0.050	0.060	0.080	0.090	0.110	0.130
	0.01xD	0.02xD	210-280	0.050	0.060	0.080	0.090	0.110	0.130	0.01xD	0.65xD	160-220	0.050	0.060	0.080	0.090	0.110	0.130	0.01xD	0.65xD	160-220	0.050	0.060	0.080	0.090	0.110	0.130
	0.01xD	0.02xD	200-270	0.040	0.050	0.070	0.080	0.100	0.120	0.01xD	0.65xD	140-200	0.040	0.050	0.070	0.080	0.100	0.120	0.01xD	0.65xD	140-200	0.040	0.050	0.070	0.080	0.100	0.120
	0.007xD	0.017xD	120-220	0.035	0.045	0.060	0.075	0.090	0.110	0.006xD	0.45xD	100-140	0.035	0.045	0.060	0.075	0.090	0.110	0.006xD	0.45xD	100-140	0.035	0.045	0.060	0.075	0.090	0.110
	0.005xD	0.015xD	80-140	0.020	0.030	0.040	0.050	0.080	0.090	0.005xD	0.3xD	50-100	0.020	0.030	0.040	0.050	0.080	0.090	0.005xD	0.3xD	50-100	0.020	0.030	0.040	0.050	0.080	0.090
	0.008xD	0.018xD	100-180	0.040	0.050	0.070	0.080	0.100	0.120	0.008xD	0.55xD	80-140	0.040	0.050	0.070	0.080	0.100	0.120	0.008xD	0.55xD	80-140	0.040	0.050	0.070	0.080	0.100	0.120

The specified machining values are guide values.
The optimum data for the respective machining task should be determined during the test or machining.

Cutting data recommendations for corner radius milling cutters

Feed and cutting speed

OptiMill-3D-CR-Graphite | MCR111, 112, 113, 114, 115, 116

MMG*	Workpiece material	Strength/hardness [N/mm ²] [HRC]	Cooling		
			Dry	Air/MQL	KSS
N N3	N3.1 Graphite, > 8 µm			✓	✓
	N3.2 Graphite, ≤ 8 µm			✓	✓

OptiMill-3D-CR-Graphite | MCR111, 112, 113, 114, 115, 116

MMG*	Workpiece material	Strength/hardness [N/mm ²] [HRC]	Cooling		
			Dry	Air/MQL	KSS
N N3	N3.1 Graphite, > 8 µm			✓	✓
	N3.2 Graphite, ≤ 8 µm			✓	✓

OptiMill-3D-CR-Graphite | MCR111, 112, 113, 114, 115, 116

MMG*	Workpiece material	Strength/hardness [N/mm ²] [HRC]	Cooling		
			Dry	Air/MQL	KSS
N N3	N3.1 Graphite, > 8 µm			✓	✓
	N3.2 Graphite, ≤ 8 µm			✓	✓

Working depth correction factor – k_{AT}

AT	k_{AT}		
	a_p	n	v_f
≤ 3xD	1,00	1,00	1,00
≤ 5xD	0,80	0,90	0,90
≤ 6xD	0,70	0,85	0,85
≤ 8xD	0,60	0,75	0,75
≤ 10xD	0,50	0,70	0,70
≤ 12xD	0,45**	0,65	0,65
≤ 15xD	0,40**	0,60	0,60
≤ 20xD	0,35**	0,60	0,60
≤ 25xD	0,35**	0,50	0,50
≤ 30xD	0,30**	0,50	0,50
≤ 35xD	0,30**	0,50	0,50

Cone angle correction factor – k_{KW}

φ [°]	k_{KW}		
	a_p	n	v_f
0	1,00	1,00	1,00
0,5	1,01	1,01	1,01
1	1,02	1,02	1,02
1,5	1,03	1,03	1,03
3	1,06	1,06	1,06

Note:

To determine cutting data, please observe the notes on page 548-551.

* MAPAL machining groups

** Consultation with a MAPAL application engineer.

Roughing

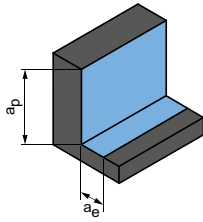

Plunge angle
1.0° - 3.0°

a_p [mm]	a_e [mm]	v_c [m/min]	f_z [mm]													
			Diameter of milling cutter [mm]													
			0.40	0.50	0.60	0.80	1.00	1.50	2.00	3.00	4.00	5.00	6.00	8.00	10.00	12.00
0.25xD	0.8xD	500-600	0.016	0.018	0.019	0.020	0.022	0.038	0.045	0.057	0.062	0.082	0.090	0.102	0.120	0.155
0.25xD	0.8xD	400-500	0.016	0.018	0.019	0.020	0.022	0.038	0.045	0.057	0.062	0.082	0.090	0.102	0.120	0.155

Finishing (3D, face milling)

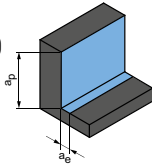

Next table:
Finishing (3D, face milling)

a_p [mm]	a_e [mm]	v_c [m/min]	f_z [mm]													
			Diameter of milling cutter [mm]													
			0.40	0.50	0.60	0.80	1.00	1.50	2.00	3.00	4.00	5.00	6.00	8.00	10.00	12.00
0.015xD	0.025xD	700-800	0.016	0.018	0.019	0.020	0.022	0.038	0.045	0.057	0.062	0.082	0.090	0.102	0.120	0.155
0.015xD	0.025xD	600-700	0.016	0.018	0.019	0.020	0.022	0.038	0.045	0.057	0.062	0.082	0.090	0.102	0.120	0.155

Finishing (flat areas)

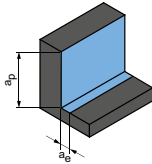

Plunge angle
0.5° - 1.0°

Next table:
Finishing (flat areas)

a_p [mm]	a_e [mm]	v_c [m/min]	f_z [mm]													
			Diameter of milling cutter [mm]													
			0.40	0.50	0.60	0.80	1.00	1.50	2.00	3.00	4.00	5.00	6.00	8.00	10.00	12.00
0.015xD	0.6xD	700-800	0.016	0.018	0.019	0.020	0.022	0.038	0.045	0.057	0.062	0.082	0.090	0.102	0.120	0.155
0.015xD	0.6xD	600-700	0.016	0.018	0.019	0.020	0.022	0.038	0.045	0.057	0.062	0.082	0.090	0.102	0.120	0.155

The specified machining values are guide values.
The optimum data for the respective machining task should be determined during the test or machining.

Cutting data recommendations for corner radius milling cutters

Feed and cutting speed

Groove milling

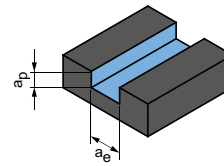

$$a_p = 0,5 \times D$$

$$a_e = 1 \times D$$

OptiMill-Diamond-Torus | SHM55

MMG*	Workpiece material	Strength/hardness [N/mm ²] [HRC]	Cooling			v _c [m/min]	f _z [mm]								
			MQL/Air	Dry	Wet		Diameter of milling cutter [mm]								
							4.00	6.00	8.00	10.00	12.00	16.00	20.00	25.00	
N	N1	N1.1 Aluminium, unalloyed and alloyed < 3% Si	✓	✓	✓	1.505	0.048	0.069	0.089	0.108	0.125	0.157	0.182	0.201	
		N1.2 Aluminium, alloyed ≤ 7% Si	✓	✓	✓	1.000	0.051	0.072	0.093	0.113	0.132	0.165	0.191	0.211	
		N1.3 Aluminium, alloyed > 7 - 12% Si	✓	✓	✓	800	0.053	0.076	0.098	0.118	0.138	0.173	0.200	0.222	
		N1.4 Aluminium, alloyed > 12% Si	✓	✓	✓	575	0.058	0.083	0.106	0.129	0.150	0.188	0.218	0.242	
	N2	N2.1 Copper, unalloyed and low alloyed	< 300	✓	✓	✓	575	0.039	0.055	0.071	0.086	0.100	0.125	0.145	0.161
		N2.2 Copper, alloyed	> 300	✓	✓	✓	430	0.039	0.055	0.071	0.086	0.100	0.125	0.145	0.161
		N2.3 Brass, bronze, gunmetal	< 1,200	✓	✓	✓	720	0.024	0.034	0.044	0.054	0.063	0.078	0.091	0.101
	N4	N4.1 Plastic, thermoplastics		✓	✓	✓	200	0.024	0.034	0.044	0.054	0.063	0.078	0.091	0.101
		N4.2 Plastic, duroplastics		✓	✓	✓	295	0.024	0.034	0.044	0.054	0.063	0.078	0.091	0.101
		N4.3 Plastic, foam materials		✓	✓		2.400	0.015	0.021	0.027	0.032	0.038	0.047	0.055	0.060
C	C1.1 Plastic range, reinforced with aramid fibre (AFK)		✓	✓	✓	215	0.034	0.048	0.062	0.075	0.088	0.110	0.127	0.141	
	C1.2 Plastic range (duroplastic), CFK/GFK		✓	✓	✓	295	0.024	0.034	0.044	0.054	0.063	0.078	0.091	0.101	
	C1.3 Plastic range (thermoplastic), CFK/GFK		✓	✓	✓	200	0.024	0.034	0.044	0.054	0.063	0.078	0.091	0.101	
	C2.1 Carbon range, reinforced with carbon fibre (CFC)		✓	✓	✓	295	0.022	0.031	0.040	0.048	0.056	0.071	0.082	0.091	

OptiMill-3D-CR-Alu | MCR119, 120

MMG*	Workpiece material	Strength/hardness [N/mm ²] [HRC]	Cooling			
			Dry	Air/MQL	KSS	
N	N1	N1.1 Aluminium, unalloyed and alloyed < 3% Si			✓	
		N1.2 Aluminium, alloyed ≤ 7% Si			✓	
		N1.3 Aluminium, alloyed > 7 - 12% Si			✓	
		N1.4 Aluminium, alloyed > 12% Si			✓	
	N2	N2.1 Copper, unalloyed and low alloyed	< 300			✓
		N2.2 Copper, alloyed	> 300			✓
		N2.3 Brass, bronze, gunmetal	< 1,200	✓	✓	✓

* MAPAL machining groups

Roughing

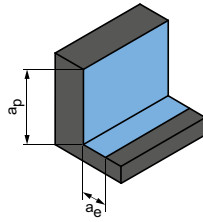

$$a_p = 0.5xD$$

$$a_e = 0.25xD$$

Finishing

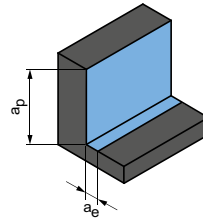

$$a_p = 0.5xD$$

$$a_e = 0.1xD$$

v_c [m/min]	f_z [mm]									v_c [m/min]	f_z [mm]								
	Diameter of milling cutter [mm]										Diameter of milling cutter [mm]								
	4.00	6.00	8.00	10.00	12.00	16.00	20.00	25.00	4.00		6.00	8.00	10.00	12.00	16.00	20.00	25.00		
3.075	0.097	0.138	0.177	0.215	0.251	0.314	0.364	0.403	4.515	0.153	0.218	0.281	0.340	0.396	0.496	0.575	0.637		
2.045	0.102	0.145	0.186	0.226	0.263	0.329	0.382	0.423	3.000	0.161	0.229	0.295	0.357	0.416	0.521	0.604	0.669		
1.635	0.107	0.152	0.195	0.237	0.276	0.345	0.400	0.443	2.400	0.168	0.240	0.309	0.374	0.436	0.546	0.632	0.700		
1.180	0.116	0.165	0.213	0.258	0.301	0.376	0.436	0.483	1.730	0.184	0.262	0.337	0.408	0.476	0.595	0.690	0.764		
1.180	0.078	0.110	0.142	0.172	0.201	0.251	0.291	0.322	1.730	0.123	0.174	0.224	0.272	0.317	0.397	0.460	0.509		
885	0.078	0.110	0.142	0.172	0.201	0.251	0.291	0.322	1.295	0.123	0.174	0.224	0.272	0.317	0.397	0.460	0.509		
1.470	0.048	0.069	0.089	0.108	0.125	0.157	0.182	0.201	2.160	0.077	0.109	0.140	0.170	0.198	0.248	0.287	0.318		
405	0.048	0.069	0.089	0.108	0.125	0.157	0.182	0.201	595	0.077	0.109	0.140	0.170	0.198	0.248	0.287	0.318		
605	0.048	0.069	0.089	0.108	0.125	0.157	0.182	0.201	885	0.077	0.109	0.140	0.170	0.198	0.248	0.287	0.318		
4.905	0.029	0.041	0.053	0.065	0.075	0.094	0.109	0.121	7.195	0.046	0.065	0.084	0.102	0.119	0.149	0.172	0.191		
440	0.068	0.097	0.124	0.151	0.175	0.220	0.254	0.282	650	0.107	0.153	0.196	0.238	0.277	0.347	0.402	0.446		
605	0.048	0.069	0.089	0.108	0.125	0.157	0.182	0.201	885	0.077	0.109	0.140	0.170	0.198	0.248	0.287	0.318		
405	0.048	0.069	0.089	0.108	0.125	0.157	0.182	0.201	595	0.077	0.109	0.140	0.170	0.198	0.248	0.287	0.318		
605	0.044	0.062	0.080	0.097	0.113	0.141	0.164	0.181	885	0.069	0.098	0.126	0.153	0.178	0.223	0.259	0.287		

Roughing

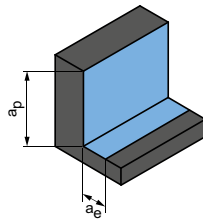

Plunge angle
1.0° - 3.0°

Next page:
Finishing (3D, face milling)

a_p [mm]	a_e [mm]	v_c [m/min]	f_z [mm]										
			Diameter of milling cutter [mm]										
			2.00	3.00	4.00	5.00	6.00	8.00	10.00	12.00	16.00	20.00	
0.15xD	0.6xD	400-600	0.038	0.057	0.062	0.082	0.090	0.102	0.120	0.155	0.180	0.205	
0.15xD	0.6xD	380-580	0.042	0.063	0.068	0.090	0.099	0.112	0.132	0.171	0.198	0.226	
0.15xD	0.6xD	340-540	0.046	0.068	0.074	0.098	0.108	0.122	0.144	0.186	0.216	0.246	
0.15xD	0.6xD	300-500	0.049	0.074	0.081	0.107	0.117	0.133	0.156	0.202	0.234	0.267	
0.15xD	0.6xD	400-500	0.038	0.057	0.062	0.082	0.090	0.102	0.120	0.155	0.180	0.205	
0.15xD	0.6xD	300-400	0.038	0.057	0.062	0.082	0.090	0.102	0.120	0.155	0.180	0.205	
0.15xD	0.6xD	400-500	0.046	0.068	0.074	0.098	0.108	0.122	0.144	0.186	0.216	0.246	

The specified machining values are guide values.

The optimum data for the respective machining task should be determined during the test or machining.

Cutting data recommendations for corner radius milling cutters

Feed and cutting speed

OptiMill-3D-CR-Alu | MCR119, 120

MMG*	Workpiece material	Strength/hardness [N/mm ²] [HRC]	Cooling		
			Dry	Air/MQL	KSS
N	N1	N1.1 Aluminium, unalloyed and alloyed < 3% Si			✓
		N1.2 Aluminium, alloyed ≤ 7% Si			✓
		N1.3 Aluminium, alloyed > 7 - 12% Si			✓
		N1.4 Aluminium, alloyed > 12% Si			✓
N	N2	N2.1 Copper, unalloyed and low alloyed	< 300		✓
		N2.2 Copper, alloyed	> 300		✓
		N2.3 Brass, bronze, gunmetal	< 1,200	✓	✓

OptiMill-3D-CR-Alu | MCR119, 120

MMG*	Workpiece material	Strength/hardness [N/mm ²] [HRC]	Cooling		
			Dry	Air/MQL	KSS
N	N1	N1.1 Aluminium, unalloyed and alloyed < 3% Si			✓
		N1.2 Aluminium, alloyed ≤ 7% Si			✓
		N1.3 Aluminium, alloyed > 7 - 12% Si			✓
		N1.4 Aluminium, alloyed > 12% Si			✓
N	N2	N2.1 Copper, unalloyed and low alloyed	< 300		✓
		N2.2 Copper, alloyed	> 300		✓
		N2.3 Brass, bronze, gunmetal	< 1,200	✓	✓

Working depth correction factor – k_{AT}

AT	k_{AT}		
	a_p	n	v_f
≤ 3xD	1,00	1,00	1,00
≤ 5xD	0,80	0,90	0,90
≤ 6xD	0,70	0,85	0,85
≤ 8xD	0,60	0,75	0,75
≤ 10xD	0,50	0,70	0,70
≤ 12xD	0,45**	0,65	0,65
≤ 15xD	0,40**	0,60	0,60
≤ 20xD	0,35**	0,60	0,60
≤ 25xD	0,35**	0,50	0,50
≤ 30xD	0,30**	0,50	0,50
≤ 35xD	0,30**	0,50	0,50

Cone angle correction factor – k_{KW}

φ [°]	k_{KW}		
	a_p	n	v_f
0	1,00	1,00	1,00
0,5	1,01	1,01	1,01
1	1,02	1,02	1,02
1,5	1,03	1,03	1,03
3	1,06	1,06	1,06

Note:

To determine cutting data, please observe the notes on page 548-551.

* MAPAL machining groups

** Consultation with a MAPAL application engineer.

**Finishing
(3D, face milling)**

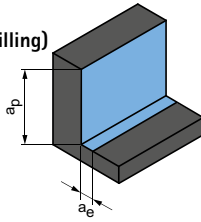

a_p [mm]	a_e [mm]	v_c [m/min]	f_z [mm]										
			Diameter of milling cutter [mm]										
			2.00	3.00	4.00	5.00	6.00	8.00	10.00	12.00	16.00	20.00	
0.015xD	0.025xD	400-600	0.038	0.057	0.062	0.082	0.090	0.102	0.120	0.155	0.180	0.205	
0.015xD	0.025xD	380-580	0.042	0.063	0.068	0.090	0.099	0.112	0.132	0.171	0.198	0.226	
0.015xD	0.025xD	340-540	0.046	0.068	0.074	0.098	0.108	0.122	0.144	0.186	0.216	0.246	
0.015xD	0.025xD	300-500	0.049	0.074	0.081	0.107	0.117	0.133	0.156	0.202	0.234	0.267	
0.015xD	0.025xD	400-500	0.038	0.057	0.062	0.082	0.090	0.102	0.120	0.155	0.180	0.205	
0.015xD	0.025xD	300-400	0.038	0.057	0.062	0.082	0.090	0.102	0.120	0.155	0.180	0.205	
0.015xD	0.025xD	400-500	0.046	0.068	0.074	0.098	0.108	0.122	0.144	0.186	0.216	0.246	

**Finishing
(flat areas)**

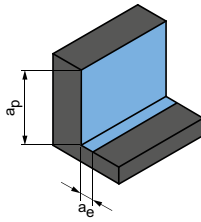

Plunge angle
0.5° - 1.0°

Next table:
Finishing (flat areas)

a_p [mm]	a_e [mm]	v_c [m/min]	f_z [mm]										
			Diameter of milling cutter [mm]										
			2.00	3.00	4.00	5.00	6.00	8.00	10.00	12.00	16.00	20.00	
0.015xD	0.6xD	400-600	0.038	0.057	0.062	0.082	0.090	0.102	0.120	0.155	0.180	0.205	
0.015xD	0.6xD	380-580	0.042	0.063	0.068	0.090	0.099	0.112	0.132	0.171	0.198	0.226	
0.015xD	0.6xD	340-540	0.046	0.068	0.074	0.098	0.108	0.122	0.144	0.186	0.216	0.246	
0.015xD	0.6xD	300-500	0.049	0.074	0.081	0.107	0.117	0.133	0.156	0.202	0.234	0.267	
0.015xD	0.6xD	400-500	0.038	0.057	0.062	0.082	0.090	0.102	0.120	0.155	0.180	0.205	
0.015xD	0.6xD	300-400	0.038	0.057	0.062	0.082	0.090	0.102	0.120	0.155	0.180	0.205	
0.015xD	0.6xD	400-500	0.046	0.068	0.074	0.098	0.108	0.122	0.144	0.186	0.216	0.246	

The specified machining values are guide values.
The optimum data for the respective machining task should be determined during the test or machining.

Cutting data recommendations for corner radius milling cutters

Feed and cutting speed

OptiMill-3D-CR-Copper | MCR117, 118

MMG*	Workpiece material	Strength/hardness [N/mm ²] [HRC]	Cooling		
			Dry	Air/MQL	KSS
N	N1	N1.1 Aluminium, unalloyed and alloyed < 3% Si			✓
		N1.2 Aluminium, alloyed ≤ 7% Si			✓
		N1.3 Aluminium, alloyed > 7 - 12% Si			✓
		N1.4 Aluminium, alloyed > 12% Si			✓
N	N2	N2.1 Copper, unalloyed and low alloyed	< 300		✓
		N2.2 Copper, alloyed	> 300		✓
		N2.3 Brass, bronze, gunmetal	< 1,200	✓	✓

OptiMill-3D-CR-Copper | MCR117, 118

MMG*	Workpiece material	Strength/hardness [N/mm ²] [HRC]	Cooling		
			Dry	Air/MQL	KSS
N	N1	N1.1 Aluminium, unalloyed and alloyed < 3% Si			✓
		N1.2 Aluminium, alloyed ≤ 7% Si			✓
		N1.3 Aluminium, alloyed > 7 - 12% Si			✓
		N1.4 Aluminium, alloyed > 12% Si			✓
N	N2	N2.1 Copper, unalloyed and low alloyed	< 300		✓
		N2.2 Copper, alloyed	> 300		✓
		N2.3 Brass, bronze, gunmetal	< 1,200	✓	✓

Working depth correction factor – k_{AT}

AT	k_{AT}		
	a_p	n	v_f
≤ 3xD	1,00	1,00	1,00
≤ 5xD	0,80	0,90	0,90
≤ 6xD	0,70	0,85	0,85
≤ 8xD	0,60	0,75	0,75
≤ 10xD	0,50	0,70	0,70
≤ 12xD	0,45**	0,65	0,65
≤ 15xD	0,40**	0,60	0,60
≤ 20xD	0,35**	0,60	0,60
≤ 25xD	0,35**	0,50	0,50
≤ 30xD	0,30**	0,50	0,50
≤ 35xD	0,30**	0,50	0,50

Cone angle correction factor – k_{KW}

φ [°]	k_{KW}		
	a_p	n	v_f
0	1,00	1,00	1,00
0,5	1,01	1,01	1,01
1	1,02	1,02	1,02
1,5	1,03	1,03	1,03
3	1,06	1,06	1,06

Note:

To determine cutting data, please observe the notes on page 548-551.

* MAPAL machining groups

** Consultation with a MAPAL application engineer.

Roughing

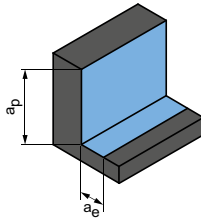

Plunge angle
1.0° - 3.0°

a_p [mm]	a_e [mm]	v_c [m/min]	f_z [mm]												
			Diameter of milling cutter [mm]												
			1.00	1.50	2.00	3.00	4.00	5.00	6.00	8.00	10.00	12.00	16.00	20.00	
0.15xD	0.6xD	400-600	0.022	0.030	0.038	0.057	0.062	0.082	0.090	0.102	0.120	0.155	0.180	0.205	
0.15xD	0.6xD	380-580	0.024	0.033	0.042	0.063	0.068	0.090	0.099	0.112	0.132	0.171	0.198	0.226	
0.15xD	0.6xD	340-540	0.026	0.036	0.046	0.068	0.074	0.098	0.108	0.122	0.144	0.186	0.216	0.246	
0.15xD	0.6xD	300-500	0.029	0.039	0.049	0.074	0.081	0.107	0.117	0.133	0.156	0.202	0.234	0.267	
0.15xD	0.6xD	400-500	0.022	0.030	0.038	0.057	0.062	0.082	0.090	0.102	0.120	0.155	0.180	0.205	
0.15xD	0.6xD	300-400	0.022	0.030	0.038	0.057	0.062	0.082	0.090	0.102	0.120	0.155	0.180	0.205	
0.15xD	0.6xD	400-500	0.026	0.036	0.046	0.068	0.074	0.098	0.108	0.122	0.144	0.186	0.216	0.246	

Next table:
Finishing (3D, face milling)

**Finishing
(3D, face milling)**

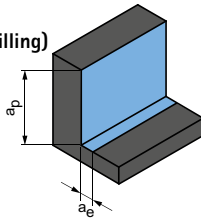

a_p [mm]	a_e [mm]	v_c [m/min]	f_z [mm]												
			Diameter of milling cutter [mm]												
			1.00	1.50	2.00	3.00	4.00	5.00	6.00	8.00	10.00	12.00	16.00	20.00	
0.015xD	0.025xD	400-600	0.022	0.030	0.038	0.057	0.062	0.082	0.090	0.102	0.120	0.155	0.180	0.205	
0.015xD	0.025xD	380-580	0.024	0.033	0.042	0.063	0.068	0.090	0.099	0.112	0.132	0.171	0.198	0.226	
0.015xD	0.025xD	340-540	0.026	0.036	0.046	0.068	0.074	0.098	0.108	0.122	0.144	0.186	0.216	0.246	
0.015xD	0.025xD	300-500	0.029	0.039	0.049	0.074	0.081	0.107	0.117	0.133	0.156	0.202	0.234	0.267	
0.015xD	0.025xD	400-500	0.022	0.030	0.038	0.057	0.062	0.082	0.090	0.102	0.120	0.155	0.180	0.205	
0.015xD	0.025xD	300-400	0.022	0.030	0.038	0.057	0.062	0.082	0.090	0.102	0.120	0.155	0.180	0.205	
0.015xD	0.025xD	400-500	0.026	0.036	0.046	0.068	0.074	0.098	0.108	0.122	0.144	0.186	0.216	0.246	

The specified machining values are guide values.
The optimum data for the respective machining task should be determined during the test or machining.

Cutting data recommendations for corner radius milling cutters

Feed and cutting speed

OptiMill-3D-CR-Copper | MCR117, 118

MMG*	Workpiece material	Strength/hardness [N/mm ²] [HRC]	Cooling			
			Dry	Air/MQL	KSS	
N	N1	N1.1 Aluminium, unalloyed and alloyed < 3% Si			✓	
		N1.2 Aluminium, alloyed ≤ 7% Si			✓	
		N1.3 Aluminium, alloyed > 7 - 12% Si			✓	
		N1.4 Aluminium, alloyed > 12% Si			✓	
	N2	N2.1 Copper, unalloyed and low alloyed	< 300			✓
		N2.2 Copper, alloyed	> 300			✓
		N2.3 Brass, bronze, gunmetal	< 1,200	✓	✓	✓

Working depth correction factor – k_{AT}

AT	k_{AT}		
	a_p	n	v_f
≤ 3xD	1,00	1,00	1,00
≤ 5xD	0,80	0,90	0,90
≤ 6xD	0,70	0,85	0,85
≤ 8xD	0,60	0,75	0,75
≤ 10xD	0,50	0,70	0,70
≤ 12xD	0,45**	0,65	0,65
≤ 15xD	0,40**	0,60	0,60
≤ 20xD	0,35**	0,60	0,60
≤ 25xD	0,35**	0,50	0,50
≤ 30xD	0,30**	0,50	0,50
≤ 35xD	0,30**	0,50	0,50

Cone angle correction factor – k_{KW}

φ [°]	k_{KW}		
	a_p	n	v_f
0	1,00	1,00	1,00
0,5	1,01	1,01	1,01
1	1,02	1,02	1,02
1,5	1,03	1,03	1,03
3	1,06	1,06	1,06

Note:

To determine cutting data, please observe the notes on page 548-551.

* MAPAL machining groups

** Consultation with a MAPAL application engineer.

Finishing
(3D, face milling)

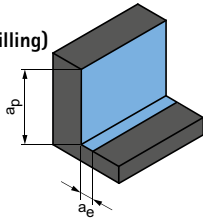

a_p [mm]	a_e [mm]	v_c [m/min]	f_z [mm]												
			Diameter of milling cutter [mm]												
			1.00	1.50	2.00	3.00	4.00	5.00	6.00	8.00	10.00	12.00	16.00	20.00	
0.015xD	0.6xD	400-600	0.022	0.030	0.038	0.057	0.062	0.082	0.090	0.102	0.120	0.155	0.180	0.205	
0.015xD	0.6xD	380-580	0.024	0.033	0.042	0.063	0.068	0.090	0.099	0.112	0.132	0.171	0.198	0.226	
0.015xD	0.6xD	340-540	0.026	0.036	0.046	0.068	0.074	0.098	0.108	0.122	0.144	0.186	0.216	0.246	
0.015xD	0.6xD	300-500	0.029	0.039	0.049	0.074	0.081	0.107	0.117	0.133	0.156	0.202	0.234	0.267	
0.015xD	0.6xD	400-500	0.022	0.030	0.038	0.057	0.062	0.082	0.090	0.102	0.120	0.155	0.180	0.205	
0.015xD	0.6xD	300-400	0.022	0.030	0.038	0.057	0.062	0.082	0.090	0.102	0.120	0.155	0.180	0.205	
0.015xD	0.6xD	400-500	0.026	0.036	0.046	0.068	0.074	0.098	0.108	0.122	0.144	0.186	0.216	0.246	

The specified machining values are guide values.
The optimum data for the respective machining task should be determined during the test or machining.





CIRCLE RADIUS MILLING CUTTER

Introduction

Introduction to the technology 142

Universal application

OptiMill-3D-CS, teardrop form 144

OptiMill-3D-CS, taper shape 145

Technical appendix

Cutting data recommendations 146

Determination of cutting data | working depth 548



OptiMill®-3D-CS

Efficient pre-finishing and finishing on 5-axis machines

The new OptiMill-3D-CS circle radius milling cutters are mainly used for deep cavities, for complex free-form surfaces and in the manufacturing of turbine blades and impellers.

One of the tool's special features is the optimal geometric combination of form cutters and radius milling cutters, which enables greater tool path distance in pre-finishing and finishing operations.

The machining time can be significantly reduced and the surface quality of the parts can be greatly improved.

If you need to machine deep, hard-to-access cavities, make the teardrop-shaped OptiMill-3D-CS your first choice. By contrast, a taper-shaped product will be highly effective at machining large surfaces and surfaces with tool restrictions.

Higher axial material removal rate (a_p) when working with the circle radius milling cutter

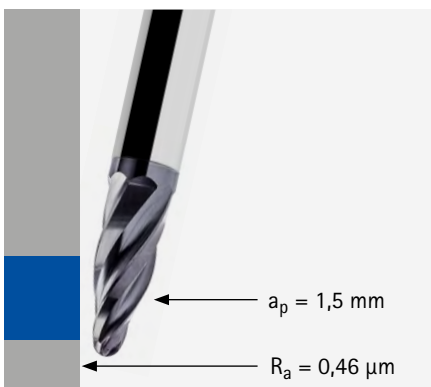

Normal axial material removal rate (a_p) when working with a ball nose milling cutter

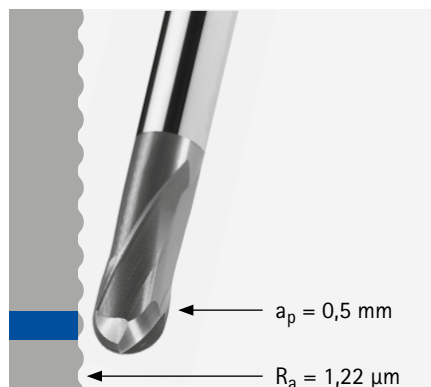

ADVANTAGES

- Increases productivity
- Process-reliable operation
- Extreme geometric flexibility
- Significantly improves surface qualities
- Keeps vibrations to a minimum
- Increases the material removal rate
- Reduces the number of milling paths

REQUIREMENTS

- CAD/CAM system for simultaneous 5-axis milling
- 5-axis machine

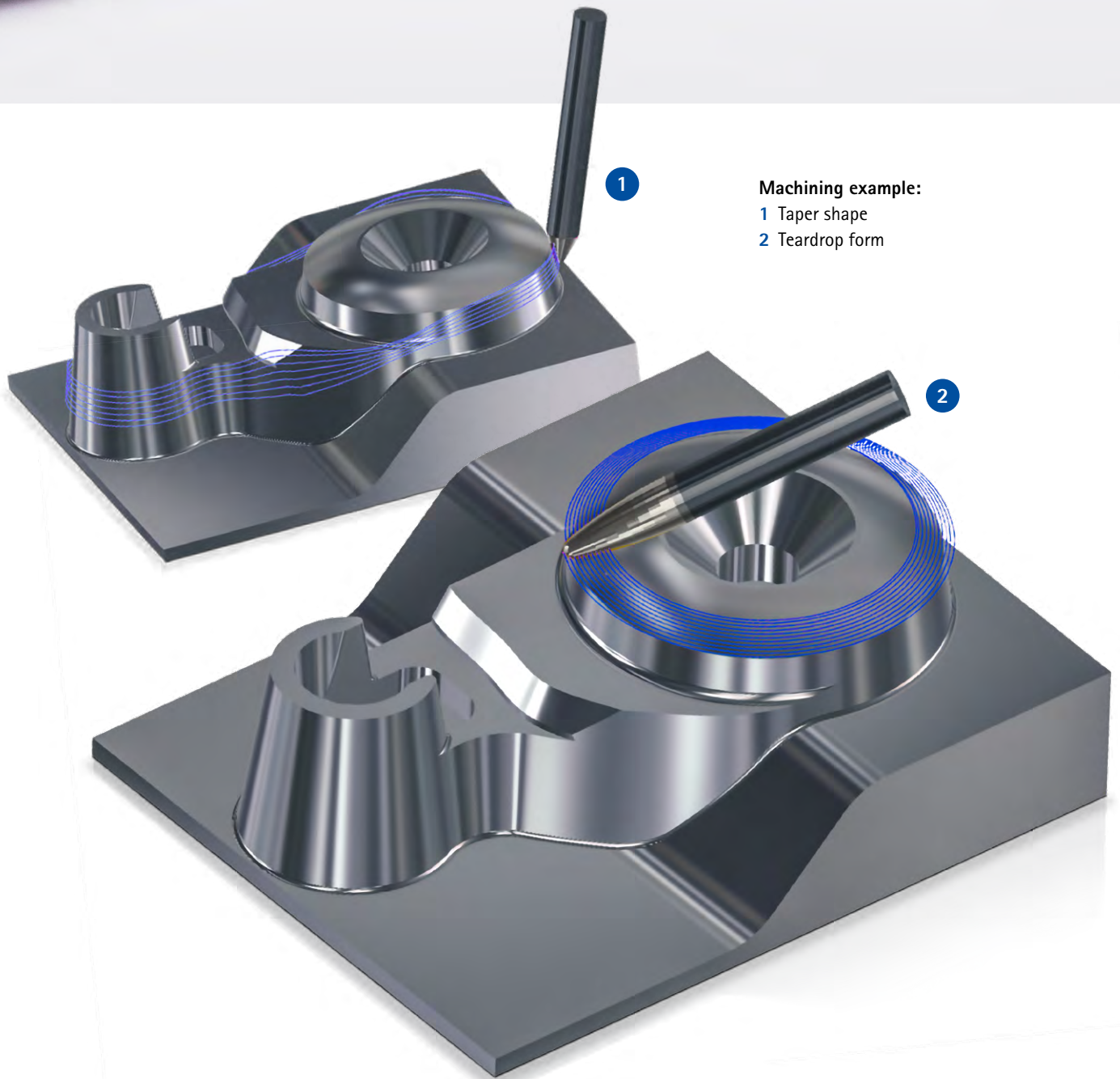

Machining example:

- 1 Taper shape
- 2 Teardrop form

OptiMill®-3D-CS

Circle radius milling cutter, teardrop form
MCS100

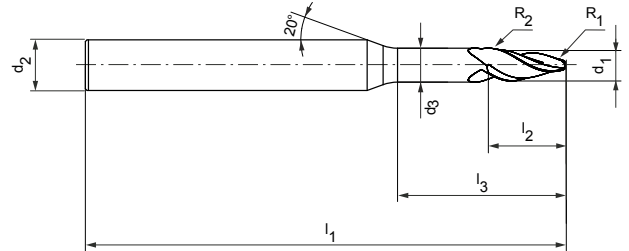
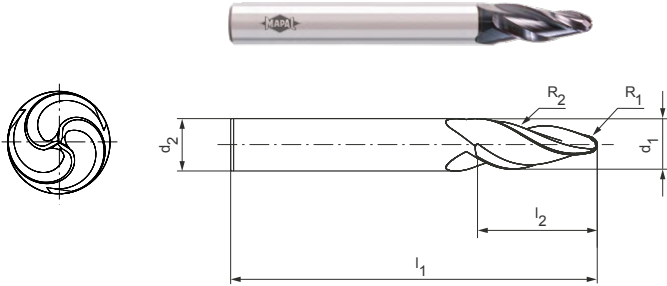

Preferred series in stock

Dimensions								z	Shank form HA	
d ₁	R ₁	R ₂	d ₂ h6	l ₁	l ₂	d ₃	l ₃		Specification	Order no.
2,00	0,5	8	4	50	3,19	2	7,5	3	MCS100-020-0050-0750T050-HP803	31150976
3,00	0,75	12	6	57	4,75	3	12	3	MCS100-030-0075-1200T057-HP803	31150977
4,00	1	16	6	57	6,39	4	15	3	MCS100-040-0100-1500T057-HP803	31150978
6,00	1	95	6	75	20,29	-	-	3	MCS100-060-0100-T075-HP803	31150979
8,00	2	64	8	75	17,62	-	-	3	MCS100-080-0200-T075-HP803	31150980
8,00	1	90	8	75	23,92	-	-	3	MCS100-080-0100-T075-HP803	31150981
10,00	2	85	10	73	24,12	-	-	4	MCS100-100-0200-T073-HP803	31150982
12,00	2	80	12	84	26,66	-	-	4	MCS100-120-0200-T084-HP803	31150983

Dimensions in mm.

For cutting data recommendations, see end of chapter.

Special designs and other coatings available upon request.

Design:

Diameter of milling cutter: 2.00 - 12.00 mm
Cutting material: HP803
Number of cutting edges: 3/4

Application:

Combination of radius and form cutters, which allows more distance between paths for pre-finishing and finishing operations.

OptiMill®-3D-CS

Circle radius milling cutter, taper shape
MCS101

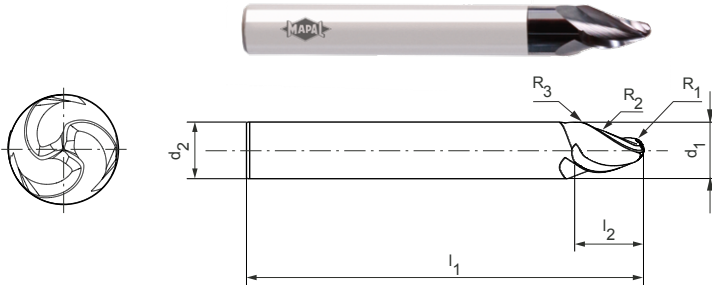

Design:

Diameter of milling cutter: 6.00 - 12.00 mm
Cutting material: HP803
Number of cutting edges: 3

Application:

Combination of radius and form cutters, which allows more distance between paths for pre-finishing and finishing operations.

Contact angle $\alpha/2$

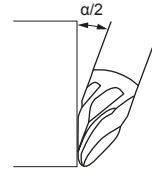

Preferred series in stock

Dimensions							z	Contact angle $\alpha/2$ [°]	Specification	Order no.
d_1	R_1	R_2	R_3	d_2 h6	l_1	l_2				
6,00	1	250	-	6	57	9,58	3	13,6	MCS101-060-0100-K057-HP803	31150984
8,00	1,5	250	4	8	64	10,5	3	16,5	MCS101-080-0150-K064-HP803	31150985
10,00	2	250	5	10	73	10,729	3	20,1	MCS101-100-0200-K073-HP803	31150986
12,00	3	250	6	12	84	13,5	3	16,7	MCS101-120-0300-K084-HP803	31150987

Dimensions in mm.

For cutting data recommendations, see end of chapter.

Special designs and other coatings available upon request.

Cutting data recommendations for circle radius milling cutters

Feed and cutting speed

Finishing

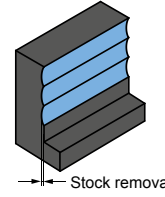

Stock removal
0.05 - 0.1 mm

OptiMill-3D-CS, teardrop form | MCS100

MMG*	Workpiece material	Strength/ hardness [N/mm ²] [HRC]	Cooling			v _c [m/min]	f _z [mm]							
			Dry	Air/MQL	KSS		Diameter of milling cutter [mm]							
							2.00	3.00	4.00	6.00	8.00	10.00	12.00	
P	P1.1	Structural, machining, case hardened and tempering steels, unalloyed	< 700	✓	✓	✓	240-280	0.020	0.030	0.040	0.045	0.060	0.070	0.085
	P1.2	Structural, machining, case hardened and tempering steels, unalloyed	< 1,200	✓	✓	✓	200-240	0.020	0.030	0.040	0.045	0.060	0.070	0.085
	P2.1	Nitriding, hardening and tempering steels, alloyed	< 900	✓	✓	✓	210-250	0.020	0.030	0.040	0.040	0.050	0.065	0.070
	P2.2	Nitriding, hardening and tempering steels, alloyed	< 1,400	✓	✓	✓	180-210	0.020	0.030	0.040	0.040	0.050	0.065	0.070
	P3.1	Tool, bearing, spring and high-speed steels**	< 800	✓	✓	✓	210-250	0.020	0.030	0.040	0.040	0.050	0.065	0.070
	P3.2	Tool, bearing, spring and high-speed steels**	< 1,000	✓	✓	✓	160-210	0.020	0.030	0.035	0.035	0.045	0.055	0.065
	P3.3	Tool, bearing, spring and high-speed steels**	< 1,500	✓	✓	✓	120-160	0.020	0.030	0.030	0.030	0.040	0.050	0.060
	P4.1	Stainless steels, ferritic and martensitic				✓	85-110	0.020	0.030	0.030	0.030	0.040	0.050	0.060
	P5.1	Cast steel				✓	180-210	0.020	0.030	0.040	0.040	0.050	0.065	0.070
P6.1	Stainless cast steels, ferritic and martensitic				✓	85-110	0.020	0.030	0.030	0.030	0.040	0.050	0.060	
M	M1.1	Stainless steels, austenitic	< 700			✓	85-110	0.020	0.025	0.025	0.030	0.040	0.050	0.060
	M1.2	Stainless steels, ferritic/austenitic (duplex)	< 1,000			✓	60-85	0.020	0.025	0.025	0.030	0.040	0.050	0.060
	M2.1	Stainless cast steel, austenitic	< 700			✓	85-110	0.020	0.025	0.025	0.030	0.040	0.050	0.060
	M3.1	Stainless cast steel, ferritic/austenitic (duplex)	< 1,000			✓	60-85	0.020	0.025	0.025	0.030	0.040	0.050	0.060
K	K1.1	Cast iron with lamellar graphite (grey cast iron), GJL	< 300	✓	✓	✓	250-280	0.020	0.030	0.040	0.050	0.065	0.080	0.100
	K2.1	Cast iron with spheroidal graphite, GJS	< 500	✓	✓	✓	220-250	0.020	0.030	0.040	0.050	0.065	0.080	0.100
	K2.2	Cast iron with spheroidal graphite, GJS	≤ 800	✓	✓	✓	190-220	0.020	0.030	0.040	0.050	0.065	0.080	0.100
	K2.3	Cast iron with spheroidal graphite, GJS	> 800	✓	✓	✓	160-190	0.020	0.030	0.040	0.050	0.065	0.080	0.100
	K3.1	Cast iron with vermicular graphite, GJV; malleable cast iron, GJM	< 500	✓	✓	✓	160-190	0.020	0.030	0.040	0.050	0.065	0.080	0.100
	K3.2	Cast iron with vermicular graphite, GJV; malleable cast iron, GJM	> 500	✓	✓	✓	160-190	0.020	0.030	0.040	0.050	0.065	0.080	0.100
N	N1.1	Aluminium, unalloyed and alloyed < 3% Si				✓	400-600	0.020	0.030	0.040	0.045	0.060	0.070	0.100
	N1.2	Aluminium, alloyed ≤ 7% Si				✓	400-600	0.020	0.030	0.040	0.045	0.060	0.070	0.100
	N1.3	Aluminium, alloyed > 7 - 12% Si				✓	300-400	0.020	0.030	0.040	0.045	0.060	0.070	0.100
	N1.4	Aluminium, alloyed > 12% Si				✓	200-300	0.020	0.030	0.040	0.045	0.060	0.070	0.100
	N2.1	Copper, unalloyed and low alloyed	< 300			✓	220-250	0.020	0.030	0.040	0.040	0.055	0.060	0.090
	N2.2	Copper, alloyed	> 300			✓	180-220	0.020	0.030	0.040	0.050	0.055	0.060	0.090
	N2.3	Brass, bronze, gunmetal	< 1,200			✓	180-220	0.020	0.030	0.040	0.050	0.055	0.060	0.090
H	H1.1	Hardened steel / cast steel	< 44 HRC	✓	✓		150-200	0.020	0.030	0.040	0.030	0.040	0.050	0.060
	H1.2	Hardened steel / cast steel	< 55 HRC	✓	✓		120-150	0.020	0.030	0.040	0.030	0.035	0.050	0.055
	H2.1	Hardened steel / cast steel	< 60 HRC	✓	✓		80-100	0.020	0.030	0.040	0.030	0.035	0.045	0.050

* MAPAL machining groups

** If the alloy parts Cr, Mo, Ni, V, W in total > 8%, then select the next highest MAPAL machining group.

Finishing

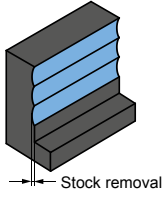

Stock removal
0.1 - 0.2 mm

Finishing

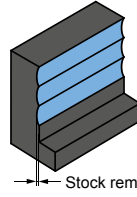

Stock removal
0.2 - 0.3 mm

	V _c [m/min]	f _z [mm]							V _c [m/min]	f _z [mm]						
		Diameter of milling cutter [mm]								Diameter of milling cutter [mm]						
		2.00	3.00	4.00	6.00	8.00	10.00	12.00		2.00	3.00	4.00	6.00	8.00	10.00	12.00
	240-280	0.020	0.030	0.040	0.045	0.060	0.070	0.085	240-280	0.020	0.030	0.040	0.045	0.060	0.070	0.085
	200-240	0.020	0.030	0.040	0.045	0.060	0.070	0.085	200-240	0.020	0.030	0.040	0.045	0.060	0.070	0.085
	210-250	0.020	0.030	0.030	0.035	0.050	0.065	0.070	210-250	0.020	0.030	0.030	0.035	0.050	0.065	0.070
	180-210	0.020	0.030	0.030	0.035	0.050	0.065	0.070	180-210	0.020	0.030	0.030	0.035	0.050	0.065	0.070
	210-250	0.020	0.030	0.030	0.035	0.050	0.065	0.070	210-250	0.020	0.030	0.030	0.035	0.050	0.065	0.070
	160-210	0.020	0.030	0.035	0.035	0.045	0.055	0.065	160-210	0.020	0.030	0.030	0.035	0.045	0.055	0.065
	120-160	0.020	0.030	0.030	0.035	0.040	0.045	0.060	120-140	0.020	0.030	0.030	0.035	0.040	0.045	0.060
	85-110	0.020	0.030	0.030	0.035	0.035	0.045	0.055	85-110	0.020	0.030	0.030	0.035	0.035	0.045	0.055
	180-210	0.020	0.030	0.030	0.035	0.050	0.065	0.070	180-210	0.020	0.030	0.030	0.035	0.050	0.065	0.070
	85-110	0.020	0.030	0.030	0.035	0.035	0.045	0.055	85-110	0.020	0.030	0.030	0.035	0.035	0.045	0.055
	85-110	0.020	0.025	0.025	0.025	0.035	0.045	0.055	85-110	0.020	0.025	0.025	0.025	0.035	0.045	0.055
	60-85	0.020	0.025	0.025	0.025	0.035	0.045	0.055	60-85	0.020	0.025	0.025	0.025	0.035	0.045	0.055
	85-110	0.020	0.025	0.025	0.025	0.035	0.045	0.055	85-110	0.020	0.025	0.025	0.025	0.035	0.045	0.055
	60-85	0.020	0.025	0.025	0.025	0.035	0.045	0.055	60-85	0.020	0.025	0.025	0.025	0.035	0.045	0.055
	250-280	0.020	0.030	0.040	0.050	0.065	0.080	0.100	250-280	0.020	0.030	0.040	0.050	0.065	0.080	0.100
	220-250	0.020	0.030	0.040	0.050	0.065	0.080	0.100	220-250	0.020	0.030	0.040	0.050	0.065	0.080	0.100
	190-220	0.020	0.030	0.040	0.050	0.065	0.080	0.100	190-220	0.020	0.030	0.040	0.050	0.065	0.080	0.100
	160-190	0.020	0.030	0.040	0.050	0.065	0.080	0.100	160-190	0.020	0.030	0.040	0.050	0.065	0.080	0.100
	160-190	0.020	0.030	0.040	0.050	0.065	0.080	0.100	160-190	0.020	0.030	0.040	0.050	0.065	0.080	0.100
	160-190	0.020	0.030	0.040	0.050	0.065	0.080	0.100	160-190	0.020	0.030	0.040	0.050	0.065	0.080	0.100
	400-600	0.020	0.030	0.040	0.035	0.050	0.055	0.090	400-600	0.020	0.030	0.040	0.035	0.050	0.055	0.090
	400-600	0.020	0.030	0.040	0.035	0.050	0.055	0.090	400-600	0.020	0.030	0.040	0.035	0.050	0.055	0.090
	300-400	0.020	0.030	0.040	0.045	0.060	0.070	0.100	300-400	0.020	0.030	0.040	0.045	0.060	0.070	0.100
	200-300	0.020	0.030	0.040	0.045	0.060	0.070	0.100	200-300	0.020	0.030	0.040	0.045	0.060	0.070	0.100
	220-250	0.020	0.030	0.040	0.030	0.050	0.055	0.085	220-250	0.020	0.030	0.040	0.030	0.050	0.055	0.085
	180-220	0.020	0.030	0.040	0.030	0.050	0.055	0.085	180-220	0.020	0.030	0.040	0.030	0.050	0.055	0.085
	180-220	0.020	0.030	0.040	0.030	0.050	0.055	0.085	180-220	0.020	0.030	0.040	0.030	0.050	0.055	0.085
	150-200	0.020	0.030	0.040	0.025	0.035	0.045	0.055	150-200	0.020	0.030	0.040	0.025	0.035	0.045	0.055
	120-150	0.020	0.030	0.040	0.025	0.030	0.045	0.050	120-150	0.020	0.030	0.040	0.025	0.030	0.045	0.050
	80-100	0.020	0.030	0.040	0.025	0.030	0.040	0.050	80-100	0.020	0.030	0.040	0.025	0.030	0.040	0.050

The specified machining values are guide values.
The optimum data for the respective machining task should be determined during the test or machining.

Cutting data recommendations for circle radius milling cutters

Feed and cutting speed

OptiMill-3D-CS, taper shape | MCS101

MMG*	Workpiece material	Strength/hardness [N/mm ²] [HRC]	Cooling			
			Dry	Air/MQL	KSS	
P	P1.1	Structural, machining, case hardened and tempering steels, unalloyed	< 700	✓	✓	✓
	P1.2	Structural, machining, case hardened and tempering steels, unalloyed	< 1,200	✓	✓	✓
	P2.1	Nitriding, hardening and tempering steels, alloyed	< 900	✓	✓	✓
	P2.2	Nitriding, hardening and tempering steels, alloyed	< 1,400	✓	✓	✓
	P3.1	Tool, bearing, spring and high-speed steels**	< 800	✓	✓	✓
	P3.2	Tool, bearing, spring and high-speed steels**	< 1,000	✓	✓	✓
	P3.3	Tool, bearing, spring and high-speed steels**	< 1,500	✓	✓	✓
	P4.1	Stainless steels, ferritic and martensitic				✓
	P5.1	Cast steel				✓
	P6.1	Stainless cast steels, ferritic and martensitic				✓
M	M1.1	Stainless steels, austenitic	< 700			✓
	M1.2	Stainless steels, ferritic/austenitic (duplex)	< 1,000			✓
	M2.1	Stainless cast steel, austenitic	< 700			✓
	M3.1	Stainless cast steel, ferritic/austenitic (duplex)	< 1,000			✓
K	K1.1	Cast iron with lamellar graphite (grey cast iron), GJL	< 300	✓	✓	✓
	K2.1	Cast iron with spheroidal graphite, GJS	< 500	✓	✓	✓
	K2.2	Cast iron with spheroidal graphite, GJS	≤ 800	✓	✓	✓
	K2.3	Cast iron with spheroidal graphite, GJS	> 800	✓	✓	✓
	K3.1	Cast iron with vermicular graphite, GJV; malleable cast iron, GJM	< 500	✓	✓	✓
	K3.2	Cast iron with vermicular graphite, GJV; malleable cast iron, GJM	> 500	✓	✓	✓
N	N1.1	Aluminium, unalloyed and alloyed < 3% Si				✓
	N1.2	Aluminium, alloyed ≤ 7% Si				✓
	N1.3	Aluminium, alloyed > 7 - 12% Si				✓
	N1.4	Aluminium, alloyed > 12% Si				✓
	N2.1	Copper, unalloyed and low alloyed	< 300			✓
	N2.2	Copper, alloyed	> 300			✓
	N2.3	Brass, bronze, gunmetal	< 1,200			✓
H	H1.1	Hardened steel / cast steel	< 44 HRC	✓	✓	
	H1.2	Hardened steel / cast steel	< 55 HRC	✓	✓	
	H2.1	Hardened steel / cast steel	< 60 HRC	✓	✓	

* MAPAL machining groups

** If the alloy parts Cr, Mo, Ni, V, W in total > 8%, then select the next highest MAPAL machining group.

Finishing

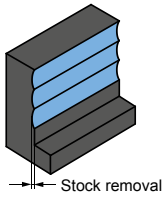

Stock removal
0.05 - 0.1 mm

Finishing

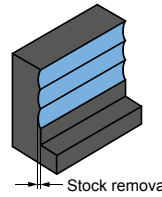

Stock removal
0.1 - 0.2 mm

	v_c [m/min]	f_z [mm]				v_c [m/min]	f_z [mm]			
		Diameter of milling cutter [mm]					Diameter of milling cutter [mm]			
		6.00	8.00	10.00	12.00		6.00	8.00	10.00	12.00
	240-280	0.045	0.060	0.070	0.085	240-280	0.045	0.060	0.070	0.085
	200-240	0.045	0.060	0.070	0.085	200-240	0.045	0.060	0.070	0.085
	210-250	0.040	0.050	0.065	0.070	210-250	0.035	0.050	0.065	0.070
	180-210	0.040	0.050	0.065	0.070	180-210	0.035	0.050	0.065	0.070
	210-250	0.040	0.050	0.065	0.070	210-250	0.035	0.050	0.065	0.070
	160-210	0.035	0.045	0.055	0.065	160-210	0.032	0.045	0.055	0.065
	120-160	0.030	0.040	0.050	0.060	120-160	0.028	0.040	0.045	0.060
	85-110	0.030	0.040	0.050	0.060	85-110	0.025	0.035	0.045	0.055
	180-210	0.040	0.050	0.065	0.070	180-210	0.035	0.050	0.065	0.070
	85-110	0.030	0.040	0.050	0.060	85-110	0.025	0.035	0.045	0.055
	85-110	0.030	0.040	0.050	0.060	85-110	0.025	0.035	0.045	0.055
	60-85	0.030	0.040	0.050	0.060	60-85	0.025	0.035	0.045	0.055
	85-110	0.030	0.040	0.050	0.060	85-110	0.025	0.035	0.045	0.055
	60-85	0.030	0.040	0.050	0.060	60-85	0.025	0.035	0.045	0.055
	250-280	0.050	0.065	0.080	0.100	250-280	0.050	0.065	0.080	0.100
	220-250	0.050	0.065	0.080	0.100	220-250	0.050	0.065	0.080	0.100
	190-220	0.050	0.065	0.080	0.100	190-220	0.050	0.065	0.080	0.100
	160-190	0.050	0.065	0.080	0.100	160-190	0.050	0.065	0.080	0.100
	160-190	0.050	0.065	0.080	0.100	160-190	0.050	0.065	0.080	0.100
	160-190	0.050	0.065	0.080	0.100	160-190	0.050	0.065	0.080	0.100
	400-600	0.045	0.060	0.070	0.100	400-600	0.035	0.050	0.055	0.090
	400-600	0.045	0.060	0.070	0.100	400-600	0.035	0.050	0.055	0.090
	300-400	0.045	0.060	0.070	0.100	300-400	0.045	0.060	0.070	0.100
	200-300	0.045	0.060	0.070	0.100	200-300	0.045	0.060	0.070	0.100
	220-250	0.040	0.055	0.060	0.090	220-250	0.030	0.050	0.055	0.085
	180-220	0.050	0.055	0.060	0.090	180-220	0.030	0.050	0.055	0.085
	180-220	0.050	0.055	0.060	0.090	180-220	0.030	0.050	0.055	0.085
	150-200	0.030	0.040	0.050	0.060	150-200	0.025	0.035	0.045	0.055
	120-150	0.030	0.035	0.050	0.055	120-150	0.025	0.030	0.045	0.050
	80-100	0.030	0.035	0.045	0.050	80-100	0.025	0.030	0.040	0.050

The specified machining values are guide values.
The optimum data for the respective machining task should be determined during the test or machining.





HIGH-FEED MILLING CUTTER

Universal application

OptiMill-3D-HF, z=3	152
OptiMill-3D-HF, z=4	153

Hardened steel

OptiMill-3D-HF-Hardened, z=4	154
OptiMill-3D-HF-Hardened, z=6	155

Technical appendix

Cutting data recommendations	156
Determination of cutting data working depth	548

OptiMill®-3D-HF

High-feed milling cutter, design with neck, z=3
MHF100

Design:

Diameter of milling cutter: 2.00 - 16.00 mm
Cutting material: HP806
Number of cutting edges: 3
Helix angle: 5°

Application:

Especially for roughing of parts with a hardness of up to 55 HRC. The proven face geometry sets itself apart thanks to the fact it runs very quietly, even at great depths.

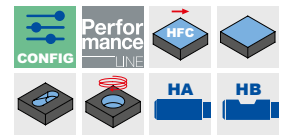
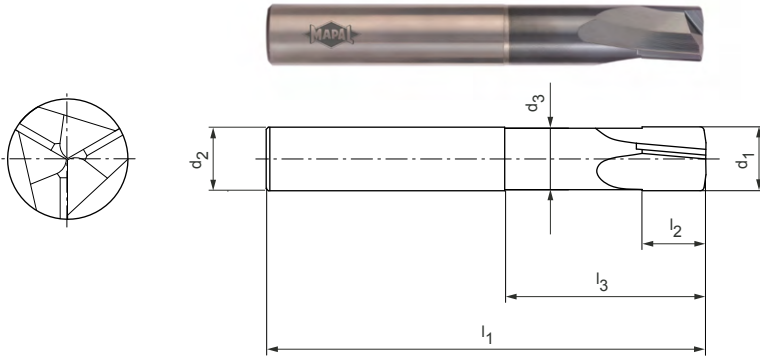

Preferred series in stock

Dimensions							z	a _p max.	PRCAM	d _{min}	Shank form HA	
d ₁	R ₁	l ₃	d ₂ h6	l ₁	l ₂	d ₃					Specification	Order no.
2,00	0,1	6	4	50	2	1,9	3	0,08	0,15	1	MHF100-020-0150-0600X050-HP806	31150882
2,00	0,1	10	4	50	2	1,9	3	0,08	0,15	1	MHF100-020-0150-1000X050-HP806	31150883
2,00	0,1	6	6	60	2	1,9	3	0,08	0,15	1	MHF100-020-0150-0600X060-HP806	31150884
2,00	0,1	10	6	60	2	1,9	3	0,08	0,15	1	MHF100-020-0150-1000X060-HP806	31150885
3,00	0,15	9	4	50	3	2,85	3	0,13	0,2	1,5	MHF100-030-0200-0900X050-HP806	31150886
3,00	0,15	15	4	50	3	2,85	3	0,13	0,2	1,5	MHF100-030-0200-1500X050-HP806	31150887
3,00	0,15	9	6	60	3	2,85	3	0,13	0,2	1,5	MHF100-030-0200-0900X060-HP806	31150888
3,00	0,15	15	6	60	3	2,85	3	0,13	0,2	1,5	MHF100-030-0200-1500X060-HP806	31150889
4,00	0,2	12	6	60	4	3,8	3	0,17	0,3	2	MHF100-040-0300-1200X060-HP806	31150900
4,00	0,2	20	6	60	4	3,8	3	0,17	0,3	2	MHF100-040-0300-2000X060-HP806	31150901
5,00	0,25	15	6	60	5	4,75	3	0,2	0,4	2,3	MHF100-050-0400-1500X060-HP806	31150902
5,00	0,25	20	6	60	5	4,75	3	0,2	0,4	2,3	MHF100-050-0400-2000X060-HP806	31150903
6,00	0,3	18	6	60	6	5,7	3	0,24	0,5	3	MHF100-060-0500-1800X060-HP806	31150904
6,00	0,3	24	6	60	6	5,7	3	0,24	0,5	3	MHF100-060-0500-2400X060-HP806	31150905
8,00	0,4	24	8	64	8	7,7	3	0,31	0,7	3,8	MHF100-080-0700-2400X064-HP806	31150906
8,00	0,4	32	8	64	8	7,7	3	0,31	0,7	3,8	MHF100-080-0700-3200X064-HP806	31150907
8,00	0,4	40	8	75	8	7,7	3	0,31	0,7	3,8	MHF100-080-0700-4000X075-HP806	31150908
10,00	0,5	30	10	75	10	9,65	3	0,39	0,85	5	MHF100-100-0850-3000X075-HP806	31150909
10,00	0,5	40	10	75	10	9,65	3	0,39	0,85	5	MHF100-100-0850-4000X075-HP806	31150910
10,00	0,5	50	10	100	10	9,65	3	0,39	0,85	5	MHF100-100-0850-5000X100-HP806	31150911
12,00	0,6	36	12	75	12	11,6	3	0,46	1	5,8	MHF100-120-1000-3600X075-HP806	31150912
12,00	0,6	48	12	100	12	11,6	3	0,46	1	5,8	MHF100-120-1000-4800X100-HP806	31150913
12,00	0,6	60	12	100	12	11,6	3	0,46	1	5,8	MHF100-120-1000-6000X100-HP806	31150914
16,00	0,8	48	16	100	16	15,5	3	0,61	1,4	8	MHF100-160-1400-4800X100-HP806	31150915

Configurable features

Shank form:
Shank form: HB

Dimensions in mm.
For cutting data recommendations, see end of chapter.
Special designs and other coatings available upon request.

Detailed view of face:

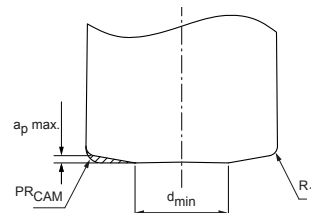

OptiMill®-3D-HF

High-feed milling cutter, design with neck
MHF101

Design:

Diameter of milling cutter: 3.00 - 16.00 mm
Cutting material: HP806
Number of cutting edges: 4
Helix angle: 5°

Application:

Especially for roughing of parts with a hardness of up to 55 HRC.

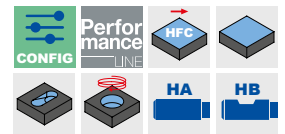
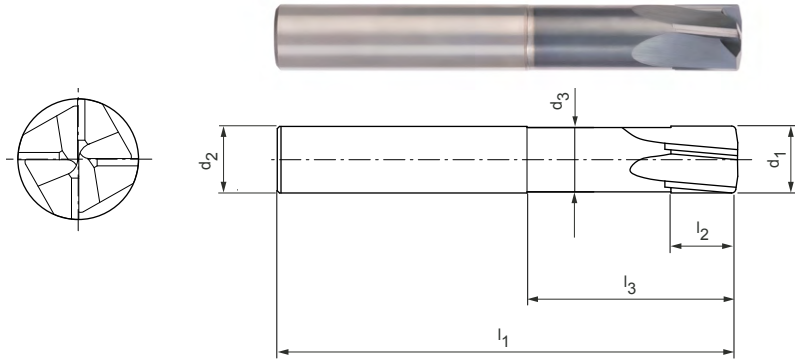

Preferred series in stock

Dimensions							z	a _p max.	PRCAM	d _{min}	Shank form HA	
d ₁	R ₁	l ₃	d ₂ h6	l ₁	l ₂	d ₃					Specification	Order no.
3,00	0,15	9	4	50	3	2,85	4	0,13	0,2	1,5	MHF101-030-0200-0900X050-HP806	31150920
3,00	0,15	15	4	50	3	2,85	4	0,13	0,2	1,5	MHF101-030-0200-1500X050-HP806	31150921
3,00	0,15	9	6	60	3	2,85	4	0,13	0,2	1,5	MHF101-030-0200-0900X060-HP806	31150922
3,00	0,15	15	6	60	3	2,85	4	0,13	0,2	1,5	MHF101-030-0200-1500X060-HP806	31150923
4,00	0,2	12	6	60	4	3,8	4	0,17	0,3	2	MHF101-040-0300-1200X060-HP806	31150924
4,00	0,2	20	6	60	4	3,8	4	0,17	0,3	2	MHF101-040-0300-2000X060-HP806	31150925
5,00	0,25	15	6	60	5	4,75	4	0,2	0,4	2,3	MHF101-050-0400-1500X060-HP806	31150926
5,00	0,25	20	6	60	5	4,75	4	0,2	0,4	2,3	MHF101-050-0400-2000X060-HP806	31150927
6,00	0,3	18	6	60	6	5,7	4	0,24	0,5	3	MHF101-060-0500-1800X060-HP806	31150928
6,00	0,3	24	6	60	6	5,7	4	0,24	0,5	3	MHF101-060-0500-2400X060-HP806	31150929
8,00	0,4	24	8	64	8	7,7	4	0,31	0,7	3,8	MHF101-080-0700-2400X064-HP806	31150930
8,00	0,4	32	8	64	8	7,7	4	0,31	0,7	3,8	MHF101-080-0700-3200X064-HP806	31150931
8,00	0,4	40	8	75	8	7,7	4	0,31	0,7	3,8	MHF101-080-0700-4000X075-HP806	31150932
10,00	0,5	30	10	75	10	9,65	4	0,39	0,85	5	MHF101-100-0850-3000X075-HP806	31150933
10,00	0,5	40	10	75	10	9,65	4	0,39	0,85	5	MHF101-100-0850-4000X075-HP806	31150934
10,00	0,5	50	10	100	10	9,65	4	0,39	0,85	5	MHF101-100-0850-5000X100-HP806	31150935
12,00	0,6	36	12	75	12	11,6	4	0,46	1	5,8	MHF101-120-1000-3600X075-HP806	31150936
12,00	0,6	48	12	100	12	11,6	4	0,46	1	5,8	MHF101-120-1000-4800X100-HP806	31150937
12,00	0,6	60	12	100	12	11,6	4	0,46	1	5,8	MHF101-120-1000-6000X100-HP806	31150938
16,00	0,8	48	16	100	16	15,5	4	0,61	1,4	8	MHF101-160-1000-4800X100-HP806	31150939

Configurable features



Shank form:
Shank form: HB



Detailed view of face:

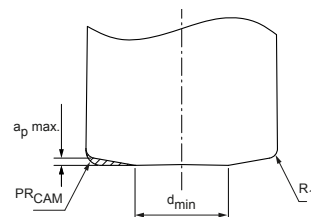

Dimensions in mm.

For cutting data recommendations, see end of chapter.

Special designs and other coatings available upon request.

OptiMill®-3D-HF-Hardened

High-feed milling cutter with innovative face geometry, design with neck
MHF102

Design:

Diameter of milling cutter: 2.00 - 16.00 mm
Cutting material: HP810
Number of cutting edges: 4
Helix angle: 12°
Special feature: Innovative face geometry

Application:

Especially for roughing and finishing of hardened parts with a hardness of 45 HRC or higher, as well as in interrupted cut. The innovative face geometry allows very good surface finishes to be achieved during finishing.

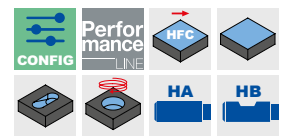
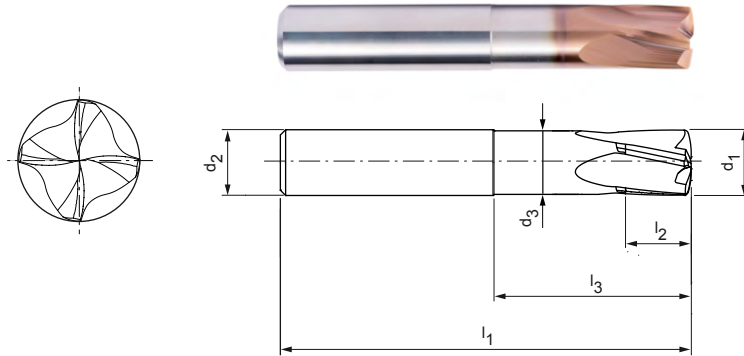

Preferred series in stock

Dimensions								z	ap max.	PR _{CAM}	d _{min}	Shank form HA	
d ₁	R ₁	R ₂	l ₃	d ₂ h5	l ₁	l ₂	d ₃					Specification	Order no.
2,00	0,1	2,3	6	4	50	2	1,9	4	0,09	0,18	0,6	MHF102-020-0180-0600X050-HP810	31150940
2,00	0,1	2,3	10	4	50	2	1,9	4	0,09	0,18	0,6	MHF102-020-0180-1000X050-HP810	31150941
2,00	0,1	2,3	6	6	60	2	1,9	4	0,09	0,18	0,6	MHF102-020-0180-0600X060-HP810	31150942
2,00	0,1	2,3	10	6	60	2	1,9	4	0,09	0,18	0,6	MHF102-020-0180-1000X060-HP810	31150943
3,00	0,15	3,45	9	4	50	3	2,85	4	0,13	0,275	0,9	MHF102-030-0278-0900X050-HP810	31150944
3,00	0,15	3,45	15	4	50	3	2,85	4	0,13	0,275	0,9	MHF102-030-0275-1500X050-HP810	31150945
3,00	0,15	3,45	9	6	60	3	2,85	4	0,13	0,275	0,9	MHF102-030-0275-0900X060-HP810	31150946
3,00	0,15	3,45	15	6	60	3	2,85	4	0,13	0,275	0,9	MHF102-030-0275-1500X060-HP810	31150947
4,00	0,2	4,6	12	6	60	4	3,8	4	0,17	0,368	1,2	MHF102-040-0368-1200X060-HP810	31150948
4,00	0,2	4,6	20	6	60	4	3,8	4	0,17	0,368	1,2	MHF102-040-0368-2000X060-HP810	31150949
5,00	0,25	5,75	15	6	60	5	4,75	4	0,22	0,46	1,5	MHF102-050-0460-1500X060-HP810	31150950
5,00	0,25	5,75	20	6	60	5	4,75	4	0,22	0,46	1,5	MHF102-050-0460-2000X060-HP810	31150951
6,00	0,3	6,9	18	6	60	6	5,7	4	0,26	0,55	1,8	MHF102-060-0550-1800X060-HP810	31150952
6,00	0,3	6,9	24	6	60	6	5,7	4	0,26	0,55	1,8	MHF102-060-0550-2400X060-HP810	31150953
8,00	0,4	9,2	24	8	64	8	7,7	4	0,35	0,74	2,4	MHF102-080-0740-2400X064-HP810	31150954
8,00	0,4	9,2	32	8	64	8	7,7	4	0,35	0,74	2,4	MHF102-080-0740-3200X064-HP810	31150955
8,00	0,4	9,2	40	8	75	8	7,7	4	0,35	0,74	2,4	MHF102-080-0740-4000X075-HP810	31150956
10,00	0,5	11,5	30	10	75	10	9,65	4	0,44	0,92	3	MHF102-100-0920-3000X075-HP810	31150957
10,00	0,5	11,5	40	10	75	10	9,65	4	0,44	0,92	3	MHF102-100-0920-4000X075-HP810	31150958
10,00	0,5	11,5	50	10	100	10	9,65	4	0,44	0,92	3	MHF102-100-0920-5000X100-HP810	31150959
12,00	0,6	13,8	36	12	75	12	11,6	4	0,52	1,11	3,6	MHF102-120-1110-3600X075-HP810	31150960
12,00	0,6	13,8	48	12	100	12	11,6	4	0,52	1,11	3,6	MHF102-120-1110-4800X100-HP810	31150961
12,00	0,6	13,8	60	12	100	12	11,6	4	0,52	1,11	3,6	MHF102-120-1110-6000X100-HP810	31150962
16,00	0,8	18,4	48	16	100	16	15,5	4	0,7	1,47	4,8	MHF102-160-1470-4800X100-HP810	31150963

Configurable features

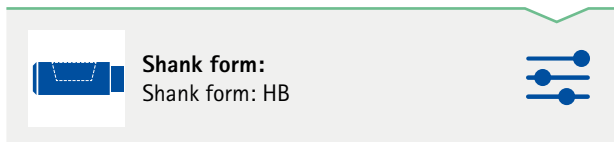

Detailed view of face:

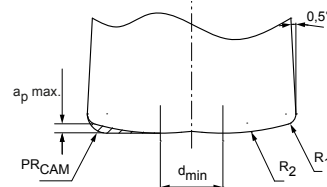

Dimensions in mm.

For cutting data recommendations, see end of chapter.

Special designs and other coatings available upon request.

OptiMill®-3D-HF-Hardened

High-feed milling cutter with innovative face geometry, design with neck, z=6
MHF103

Design:

Diameter of milling cutter: 6.00 - 16.00 mm
Cutting material: HP810
Number of cutting edges: 6
Helix angle: 12°

Application:

Especially for roughing and finishing of hardened parts with a hardness of 56 HRC or higher, as well as in interrupted cut. The innovative face geometry allows very good surface finishes to be achieved during finishing.

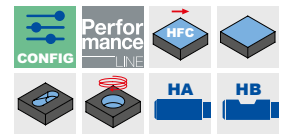
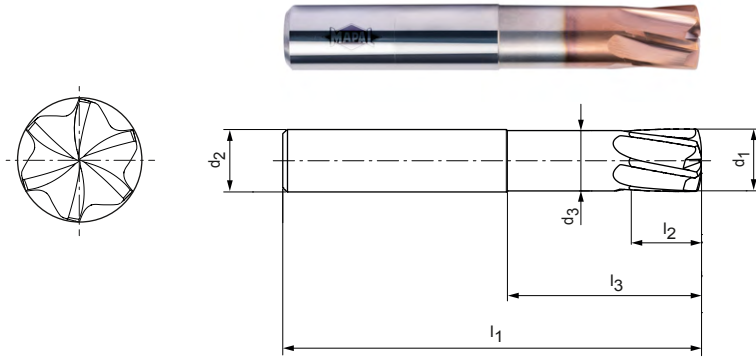

Preferred series in stock

Dimensions								z	a _p max.	PR _{CAM}	d _{min}	Shank form HA	
d ₁	R ₁	R ₂	l ₃	d ₂ h5	l ₁	l ₂	d ₃					Specification	Order no.
6,00	0,3	6,9	18	6	60	6	5,7	6	0,26	0,55	1,8	MHF103-060-0550-1800X060-HP810	31150964
6,00	0,3	6,9	24	6	60	6	5,7	6	0,26	0,55	1,8	MHF103-060-0550-2400X060-HP810	31150965
8,00	0,4	9,2	24	8	64	8	7,7	6	0,35	0,74	2,4	MHF103-080-0740-2400X064-HP810	31150966
8,00	0,4	9,2	32	8	64	8	7,7	6	0,35	0,74	2,4	MHF103-080-0740-3200X064-HP810	31150967
8,00	0,4	9,2	40	8	75	8	7,7	6	0,35	0,74	2,4	MHF103-080-0740-4000X075-HP810	31150968
10,00	0,5	11,5	30	10	75	10	9,65	6	0,44	0,92	3	MHF103-100-0920-3000X075-HP810	31150969
10,00	0,5	11,5	40	10	75	10	9,65	6	0,44	0,92	3	MHF103-100-0920-4000X075-HP810	31150970
10,00	0,5	11,5	50	10	100	10	9,65	6	0,44	0,92	3	MHF103-100-0920-5000X100-HP810	31150971
12,00	0,6	13,8	36	12	75	12	11,6	6	0,52	1,11	3,6	MHF103-120-1110-3600X075-HP810	31150972
12,00	0,6	13,8	48	12	100	12	11,6	6	0,52	1,11	3,6	MHF103-120-1110-4800X100-HP810	31150973
12,00	0,6	13,8	60	12	100	12	11,6	6	0,52	1,11	3,6	MHF103-120-1110-6000X100-HP810	31150974
16,00	0,8	18,4	48	16	100	16	15,5	6	0,7	1,47	4,8	MHF103-160-1470-4800X100-HP810	31150975

Configurable features

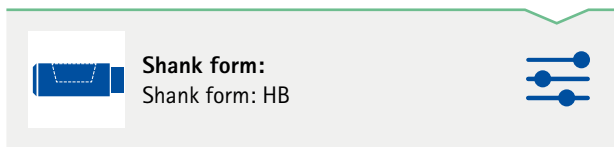

Detailed view of face:

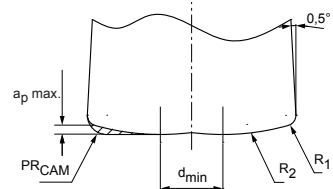

Dimensions in mm.

For cutting data recommendations, see end of chapter.

Special designs and other coatings available upon request.

Cutting data recommendations for high-feed milling cutters

Feed and cutting speed

OptiMill-3D-HF | MHF100

MMG*	Workpiece material	Strength/hardness [N/mm ²] [HRC]	Cooling			
			Dry	Air/MQL	KSS	
P	P1.1	Structural, machining, case hardened and tempering steels, unalloyed	< 700	✓	✓	
	P1.2	Structural, machining, case hardened and tempering steels, unalloyed	< 1,200	✓	✓	
	P2.1	Nitriding, hardening and tempering steels, alloyed	< 900	✓	✓	
	P2.2	Nitriding, hardening and tempering steels, alloyed	< 1,400	✓	✓	
	P3.1	Tool, bearing, spring and high-speed steels**	< 800	✓	✓	
	P3.2	Tool, bearing, spring and high-speed steels**	< 1,000	✓	✓	
	P3.3	Tool, bearing, spring and high-speed steels**	< 1,500	✓	✓	
	P4.1	Stainless steels, ferritic and martensitic			✓	✓
	P5.1	Cast steel			✓	✓
	P6.1	Stainless cast steels, ferritic and martensitic			✓	✓
M	M1.1	Stainless steels, austenitic	< 700			✓
	M1.2	Stainless steels, ferritic/austenitic (duplex)	< 1,000			✓
	M2.1	Stainless cast steel, austenitic	< 700			✓
	M3.1	Stainless cast steel, ferritic/austenitic (duplex)	< 1,000			✓
K	K1.1	Cast iron with lamellar graphite (grey cast iron), GJL	< 300	✓	✓	
	K2.1	Cast iron with spheroidal graphite, GJS	< 500	✓	✓	
	K2.2	Cast iron with spheroidal graphite, GJS	≤ 800	✓	✓	
	K2.3	Cast iron with spheroidal graphite, GJS	> 800	✓	✓	
	K3.1	Cast iron with vermicular graphite, GJV; malleable cast iron, GJM	< 500	✓	✓	
	K3.2	Cast iron with vermicular graphite, GJV; malleable cast iron, GJM	> 500	✓	✓	
S	S1.1	Titanium, titanium alloys	< 400			✓
	S2.1	Titanium, titanium alloys	< 1,200			✓
	S2.2	Titanium, titanium alloys	> 1,200			✓
H	H1.1	Hardened steel / cast steel	< 44 HRC	✓	✓	
	H1.2	Hardened steel / cast steel	< 55 HRC	✓	✓	
	H2.1	Hardened steel / cast steel	< 60 HRC	✓	✓	

* MAPAL machining groups

** If the alloy parts Cr, Mo, Ni, V, W in total > 8%, then select the next highest MAPAL machining group.

Roughing

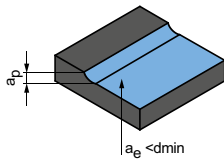

Plunge angle
1.0° - 1.5°

	a_p [mm]	a_e [mm]	v_c [m/min]	f_z [mm]								
				Diameter of milling cutter [mm]								
				2.00	3.00	4.00	5.00	6.00	8.00	10.00	12.00	16.00
	0.038xD	0.6xD	200-250	0.100	0.150	0.200	0.225	0.287	0.400	0.550	0.625	0.625
	0.038xD	0.6xD	150-200	0.100	0.150	0.200	0.225	0.287	0.400	0.550	0.625	0.625
	0.038xD	0.6xD	200-250	0.100	0.150	0.200	0.225	0.287	0.400	0.550	0.625	0.625
	0.038xD	0.65xD	150-200	0.100	0.150	0.200	0.225	0.287	0.400	0.550	0.625	0.625
	0.038xD	0.6xD	180-220	0.100	0.150	0.200	0.225	0.287	0.325	0.325	0.475	0.475
	0.038xD	0.65xD	150-180	0.100	0.150	0.200	0.225	0.287	0.325	0.325	0.475	0.475
	0.038xD	0.65xD	120-150	0.100	0.150	0.200	0.225	0.287	0.325	0.325	0.475	0.475
	0.038xD	0.6xD	90-110	0.100	0.150	0.200	0.225	0.287	0.325	0.325	0.475	0.475
	0.038xD	0.6xD	90-110	0.100	0.150	0.200	0.225	0.287	0.325	0.325	0.475	0.475
	0.038xD	0.6xD	70-90	0.100	0.150	0.200	0.225	0.287	0.325	0.325	0.475	0.475
	0.038xD	0.45xD	90-110	0.100	0.150	0.200	0.225	0.287	0.325	0.325	0.475	0.475
	0.038xD	0.45xD	70-90	0.100	0.150	0.200	0.225	0.287	0.325	0.325	0.475	0.475
	0.038xD	0.45xD	90-110	0.100	0.150	0.200	0.225	0.287	0.325	0.325	0.475	0.475
	0.038xD	0.45xD	70-90	0.100	0.150	0.200	0.225	0.287	0.325	0.325	0.475	0.475
	0.038xD	0.7xD	250-300	0.100	0.150	0.200	0.225	0.287	0.400	0.550	0.625	0.625
	0.038xD	0.7xD	250-300	0.100	0.150	0.200	0.225	0.287	0.400	0.550	0.625	0.625
	0.038xD	0.7xD	150-200	0.100	0.150	0.200	0.225	0.287	0.325	0.325	0.475	0.475
	0.038xD	0.7xD	150-200	0.100	0.150	0.200	0.225	0.287	0.325	0.325	0.475	0.475
	0.038xD	0.7xD	150-200	0.100	0.150	0.200	0.225	0.287	0.325	0.325	0.475	0.475
	0.038xD	0.7xD	150-200	0.100	0.150	0.200	0.225	0.287	0.325	0.325	0.475	0.475
	0.038xD	0.45xD	40-50	0.100	0.150	0.200	0.225	0.287	0.400	0.550	0.625	0.625
	0.038xD	0.45xD	35-40	0.100	0.150	0.200	0.225	0.287	0.400	0.550	0.625	0.625
	0.038xD	0.45xD	30-35	0.100	0.150	0.200	0.225	0.287	0.400	0.550	0.625	0.625
	0.035xD	0.7xD	150-190	0.100	0.150	0.200	0.225	0.287	0.400	0.550	0.625	0.625
	0.032xD	0.65xD	120-150	0.100	0.150	0.200	0.225	0.287	0.325	0.325	0.475	0.475
	0.028xD	0.55xD	100-120	0.100	0.150	0.175	0.200	0.250	0.250	0.300	0.350	0.400

The specified machining values are guide values.
The optimum data for the respective machining task should be determined during the test or machining.

Cutting data recommendations for high-feed milling cutters

Feed and cutting speed

OptiMill-3D-HF | MHF101

MMG*	Workpiece material	Strength/hardness [N/mm ²] [HRC]	Cooling			
			Dry	Air/MQL	KSS	
P	P1.1	Structural, machining, case hardened and tempering steels, unalloyed	< 700	✓	✓	
	P1.2	Structural, machining, case hardened and tempering steels, unalloyed	< 1,200	✓	✓	
	P2.1	Nitriding, hardening and tempering steels, alloyed	< 900	✓	✓	
	P2.2	Nitriding, hardening and tempering steels, alloyed	< 1,400	✓	✓	
	P3.1	Tool, bearing, spring and high-speed steels**	< 800	✓	✓	
	P3.2	Tool, bearing, spring and high-speed steels**	< 1,000	✓	✓	
	P3.3	Tool, bearing, spring and high-speed steels**	< 1,500	✓	✓	
	P4.1	Stainless steels, ferritic and martensitic			✓	✓
	P5.1	Cast steel			✓	✓
	P6.1	Stainless cast steels, ferritic and martensitic			✓	✓
K	K1.1	Cast iron with lamellar graphite (grey cast iron), GJL	< 300	✓	✓	
	K2.1	Cast iron with spheroidal graphite, GJS	< 500	✓	✓	
	K2.2	Cast iron with spheroidal graphite, GJS	≤ 800	✓	✓	
	K2.3	Cast iron with spheroidal graphite, GJS	> 800	✓	✓	
	K3.1	Cast iron with vermicular graphite, GJV; malleable cast iron, GJM	< 500	✓	✓	
	K3.2	Cast iron with vermicular graphite, GJV; malleable cast iron, GJM	> 500	✓	✓	
H	H1.1	Hardened steel/cast steel	< 44	✓	✓	
	H1.2	Hardened steel/cast steel	< 55	✓	✓	
	H2.1	Hardened steel/cast steel	< 60	✓	✓	

* MAPAL machining groups

** If the alloy parts Cr, Mo, Ni, V, W in total > 8%, then select the next highest MAPAL machining group.

Roughing

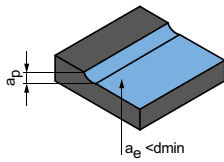

Plunge angle
1.0° - 1.5°

	a_p [mm]	a_e [mm]	v_c [m/min]	f_z [mm]								
				Diameter of milling cutter [mm]								
				2.00	3.00	4.00	5.00	6.00	8.00	10.00	12.00	16.00
	0.038xD	0.6xD	200-250	0.100	0.150	0.200	0.225	0.287	0.400	0.550	0.625	0.625
	0.038xD	0.6xD	150-200	0.100	0.150	0.200	0.225	0.287	0.400	0.550	0.625	0.625
	0.038xD	0.6xD	200-250	0.100	0.150	0.200	0.225	0.287	0.400	0.550	0.625	0.625
	0.038xD	0.65xD	150-200	0.100	0.150	0.200	0.225	0.287	0.400	0.550	0.625	0.625
	0.038xD	0.6xD	180-220	0.100	0.150	0.200	0.225	0.287	0.325	0.325	0.475	0.475
	0.038xD	0.65xD	150-180	0.100	0.150	0.200	0.225	0.287	0.325	0.325	0.475	0.475
	0.038xD	0.65xD	120-150	0.100	0.150	0.200	0.225	0.287	0.325	0.325	0.475	0.475
	0.038xD	0.6xD	90-110	0.100	0.150	0.200	0.225	0.287	0.325	0.325	0.475	0.475
	0.038xD	0.6xD	90-110	0.100	0.150	0.200	0.225	0.287	0.325	0.325	0.475	0.475
	0.038xD	0.6xD	70-90	0.100	0.150	0.200	0.225	0.287	0.325	0.325	0.475	0.475
	0.038xD	0.7xD	250-300	0.100	0.150	0.200	0.225	0.287	0.400	0.550	0.625	0.625
	0.038xD	0.7xD	250-300	0.100	0.150	0.200	0.225	0.287	0.400	0.550	0.625	0.625
	0.038xD	0.7xD	150-200	0.100	0.150	0.200	0.225	0.287	0.325	0.325	0.475	0.475
	0.038xD	0.7xD	150-200	0.100	0.150	0.200	0.225	0.287	0.325	0.325	0.475	0.475
	0.038xD	0.7xD	150-200	0.100	0.150	0.200	0.225	0.287	0.325	0.325	0.475	0.475
	0.038xD	0.7xD	150-200	0.100	0.150	0.200	0.225	0.287	0.325	0.325	0.475	0.475
	0.035xD	0.7xD	150-190	0.100	0.150	0.200	0.225	0.287	0.400	0.550	0.625	0.625
	0.032xD	0.65xD	120-150	0.100	0.150	0.200	0.225	0.287	0.325	0.325	0.475	0.475
	0.028xD	0.55xD	100-120	0.100	0.150	0.175	0.200	0.250	0.250	0.300	0.350	0.400

The specified machining values are guide values.
The optimum data for the respective machining task should be determined during the test or machining.

Cutting data recommendations for high-feed milling cutters

Feed and cutting speed

OptiMill-3D-HF-Hardened | MHF102, 103

MMG*	Workpiece material		Strength/hardness [N/mm ²] [HRC]	Cooling				
				Dry	Air/MQL	KSS		
P	P1	P1.1	Structural, machining, case hardened and tempering steels, unalloyed	< 700	✓	✓		
		P1.2	Structural, machining, case hardened and tempering steels, unalloyed	< 1,200	✓	✓		
	P2	P2.1	Nitriding, hardening and tempering steels, alloyed	< 900	✓	✓		
		P2.2	Nitriding, hardening and tempering steels, alloyed	< 1,400	✓	✓		
	P3	P3.1	Tool, bearing, spring and high-speed steels**	< 800	✓	✓		
		P3.2	Tool, bearing, spring and high-speed steels**	< 1,000	✓	✓		
		P3.3	Tool, bearing, spring and high-speed steels**	< 1,500	✓	✓		
	P4	P4.1	Stainless steels, ferritic and martensitic			✓	✓	
	P5	P5.1	Cast steel			✓	✓	
	P6	P6.1	Stainless cast steels, ferritic and martensitic			✓	✓	
	K	K1	K1.1	Cast iron with lamellar graphite (grey cast iron), GJL	< 300	✓	✓	
			K2.1	Cast iron with spheroidal graphite, GJS	< 500	✓	✓	
K2		K2.2	Cast iron with spheroidal graphite, GJS	≤ 800	✓	✓		
		K2.3	Cast iron with spheroidal graphite, GJS	> 800	✓	✓		
K3		K3.1	Cast iron with vermicular graphite, GJV; malleable cast iron, GJM	< 500	✓	✓		
		K3.2	Cast iron with vermicular graphite, GJV; malleable cast iron, GJM	> 500	✓	✓		
H	H1	H1.1	Hardened steel/cast steel	< 44	✓	✓		
		H1.2	Hardened steel/cast steel	< 55	✓	✓		
	H2	H2.1	Hardened steel/cast steel	< 60	✓			
		H2.2	Hardened steel/cast steel	< 65	✓			
		H2.3	Hardened steel/cast steel	< 68	✓			
	H3	H3.1	Wear-resistant cast / chill casting, GJN		✓	✓		

OptiMill-3D-HF-Hardened | MHF102, 103

MMG*	Workpiece material		Strength/hardness [N/mm ²] [HRC]	Cooling		
				Dry	Air/MQL	KSS
H2	H2.1	Hardened steel/cast steel	< 60		✓	
	H2.2	Hardened steel/cast steel	< 65		✓	
	H2.3	Hardened steel/cast steel	< 68		✓	
H3	H3.1	Wear-resistant cast / chill casting, GJN		✓	✓	

* MAPAL machining groups

** If the alloy parts Cr, Mo, Ni, V, W in total > 8%, then select the next highest MAPAL machining group.

Roughing

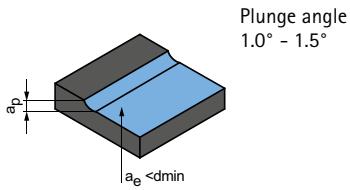

a_p [mm]	a_e [mm]	v_c [m/min]	f_z [mm]									
			Diameter of milling cutter [mm]									
			2.00	3.00	4.00	5.00	6.00	8.00	10.00	12.00	16.00	
0.042xD	0.6xD	280-340	0.100	0.130	0.180	0.210	0.250	0.350	0.460	0.580	0.700	
0.042xD	0.6xD	240-300	0.080	0.110	0.160	0.190	0.230	0.310	0.430	0.520	0.620	
0.042xD	0.6xD	260-320	0.100	0.130	0.180	0.210	0.250	0.350	0.450	0.560	0.650	
0.042xD	0.65xD	240-300	0.080	0.100	0.150	0.180	0.220	0.310	0.410	0.500	0.580	
0.042xD	0.6xD	280-340	0.100	0.130	0.170	0.200	0.240	0.340	0.430	0.520	0.620	
0.042xD	0.65xD	260-300	0.090	0.100	0.150	0.180	0.220	0.300	0.390	0.460	0.580	
0.042xD	0.65xD	240-280	0.080	0.100	0.140	0.170	0.210	0.290	0.380	0.440	0.560	
0.042xD	0.6xD	160-200	0.100	0.130	0.180	0.210	0.250	0.350	0.400	0.500	0.620	
0.042xD	0.6xD	180-220	0.100	0.110	0.160	0.200	0.230	0.330	0.380	0.470	0.590	
0.042xD	0.6xD	160-200	0.100	0.110	0.160	0.200	0.230	0.320	0.370	0.450	0.570	
0.042xD	0.7xD	250-300	0.100	0.130	0.180	0.210	0.250	0.350	0.460	0.580	0.700	
0.042xD	0.7xD	250-300	0.080	0.110	0.160	0.190	0.230	0.310	0.430	0.520	0.620	
0.042xD	0.7xD	200-250	0.100	0.130	0.180	0.210	0.250	0.350	0.450	0.560	0.650	
0.042xD	0.7xD	200-250	0.080	0.100	0.150	0.180	0.220	0.310	0.410	0.500	0.580	
0.042xD	0.7xD	220-270	0.100	0.130	0.180	0.210	0.250	0.350	0.450	0.560	0.650	
0.042xD	0.7xD	200-250	0.080	0.100	0.150	0.180	0.220	0.310	0.410	0.500	0.580	
0.042xD		180-250	0.071	0.103	0.135	0.170	0.210	0.280	0.350	0.420	0.560	
0.042xD	0.65xD	150-200	0.066	0.096	0.127	0.158	0.190	0.256	0.320	0.385	0.510	
0.040xD	0.55xD	110-150	0.062	0.083	0.106	0.142	0.172	0.220	0.280	0.330	0.420	
0.030xD	0.4xD	80-120	0.044	0.065	0.086	0.109	0.131	0.170	0.210	0.245	0.305	
0.022xD	0.35xD	60-85	0.027	0.046	0.066	0.084	0.100	0.130	0.150	0.180	0.210	
0.035xD	0.45xD	90-120	0.055	0.070	0.090	0.120	0.140	0.180	0.220	0.250	0.320	

**Finishing
(flat areas)**

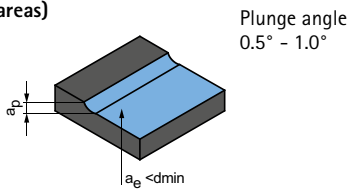

a_p [mm]	a_e [mm]	v_c [m/min]	f_z [mm]									
			Diameter of milling cutter [mm]									
			2.00	3.00	4.00	5.00	6.00	8.00	10.00	12.00	16.00	
0.080xD	0.8xD	160-185	0.040	0.048	0.058	0.072	0.105	0.144	0.182	0.210	0.290	
0.040xD	0.72xD	130-170	0.028	0.037	0.046	0.063	0.084	0.110	0.148	0.174	0.221	
0.020xD	0.6xD	110-130	0.018	0.028	0.038	0.055	0.070	0.082	0.118	0.140	0.162	
0.060xD	0.8xD	160-180	0.038	0.042	0.055	0.070	0.092	0.128	0.160	0.190	0.270	

For finishing operations on planar surfaces, depending on the material removal rate (a_e) and the selected machining strategy, residual material may remain on the part. For this reason, $a_e < d_{min}$ should be selected for planar surfaces.

The specified machining values are guide values.
The optimum data for the respective machining task should be determined during the test or machining.





SHOULDER MILLING CUTTER

Steel, stainless steel and cast iron

OptiMill-Uni-HPC-Plus	164
OptiMill-Uni-HPC-Finish	171
OptiMill-Uni-Wave	175
OptiMill-Uni-HPC-Pocket	180

Hardened steel

OptiMill-Hardened	186
OptiMill-Hardened-Finish	188

Graphite, aluminium and copper

OptiMill-Alu-HPC-Pocket	184
OptiMill-Graphite-MT	193
OptiMill-Diamond-Type 51	195

Technical appendix

Cutting data recommendations	196
Determination of cutting data working depth	548

OptiMill®-Uni-HPC-Plus

Shoulder milling cutter, short design
SCM760

Design:

Diameter of milling cutter: 3.00 - 20.00 mm
Cutting material: HP920
Number of cutting edges: 4
Helix angle: 36°/38°
Special features: Unequal spacing, rounding the cutting edge

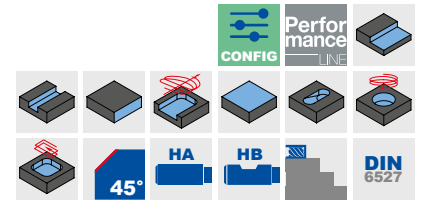
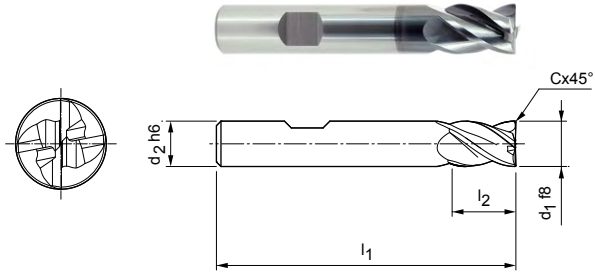

Preferred series in stock

Dimensions					z	Specification	Order no.
d ₁ f8	d ₂ h6	l ₁	l ₂	Cx45°			
3,00	6	50	6	0,06	4	SCM760-0300Z04R-F0006HB-HP920	30787363
4,00	6	54	8	0,08	4	SCM760-0400Z04R-F0008HB-HP920	30787364
5,00	6	54	9	0,10	4	SCM760-0500Z04R-F0010HB-HP920	30787365
6,00	6	54	10	0,12	4	SCM760-0600Z04R-F0012HB-HP920	30787366
8,00	8	58	12	0,16	4	SCM760-0800Z04R-F0016HB-HP920	30787367
10,00	10	66	14	0,20	4	SCM760-1000Z04R-F0020HB-HP920	30787368
12,00	12	73	16	0,24	4	SCM760-1200Z04R-F0024HB-HP920	30787369
14,00	14	73	16	0,28	4	SCM760-1400Z04R-F0028HB-HP920	30787370
16,00	16	82	22	0,32	4	SCM760-1600Z04R-F0032HB-HP920	30787371
18,00	18	82	22	0,36	4	SCM760-1800Z04R-F0036HB-HP920	30787372
20,00	20	92	26	0,40	4	SCM760-2000Z04R-F0040HB-HP920	30787373

Configurable features



Shank form:
Shank form: HA



Specification:
SCM760-0300Z04R-F0006[shank form]-HP920

Example:

SCM760-0300Z04R-F0006HA-HP920

Shank form HA

Dimensions in mm.

For cutting data recommendations, see end of chapter.

Special designs and other coatings available upon request.

OptiMill®-Uni-HPC-Plus

Shoulder milling cutter, long design with neck, design with chamfer / no chamfer
SCM770

Design:

Diameter of milling cutter: 2.50 - 25.00 mm
Cutting material: HP920
Number of cutting edges: 4
Helix angle: 36°/38°
Special features: Unequal spacing, rounding the cutting edge

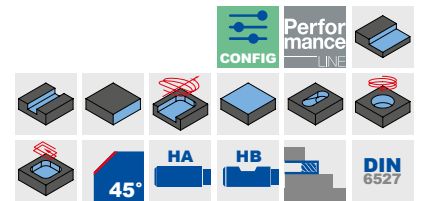
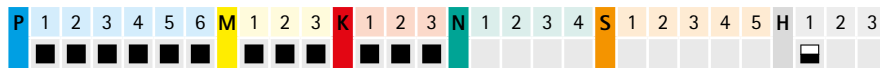
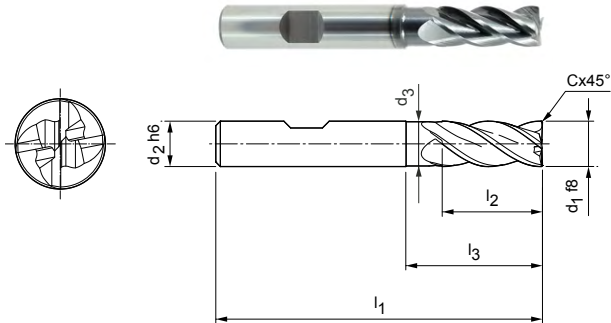

Design with chamfer | Preferred series in stock

Dimensions							z	Specification	Order no.
d1 f8	d2 h6	d3	l1	l2	l3	Cx45°			
2,50*	6	-	57	8	-	0,05	4	SCM770-0250Z04R-F0005HB-HP920	30787374
3,00*	6	-	57	8	-	0,06	4	SCM770-0300Z04R-F0006HB-HP920	30787375
4,00*	6	-	57	11	-	0,08	4	SCM770-0400Z04R-F0008HB-HP920	30787376
5,00*	6	-	57	13	-	0,10	4	SCM770-0500Z04R-F0010HB-HP920	30787377
6,00	6	5,8	57	13	20	0,12	4	SCM770-0600Z04R-F0012HB-HP920	30787378
7,00	8	6,8	63	16	25	0,14	4	SCM770-0700Z04R-F0014HB-HP920	30787379
8,00	8	7,8	63	21	25	0,16	4	SCM770-0800Z04R-F0016HB-HP920	30787380
9,00	10	8,8	72	22	30	0,18	4	SCM770-0900Z04R-F0018HB-HP920	30787381
10,00	10	9,8	72	22	30	0,20	4	SCM770-1000Z04R-F0020HB-HP920	30787382
12,00	12	11,8	83	26	36	0,24	4	SCM770-1200Z04R-F0024HB-HP920	30787383
14,00	14	13,8	83	26	36	0,28	4	SCM770-1400Z04R-F0028HB-HP920	30787390
16,00	16	15,8	92	36	42	0,32	4	SCM770-1600Z04R-F0032HB-HP920	30787391
18,00	18	17,8	92	36	47	0,36	4	SCM770-1800Z04R-F0036HB-HP920	30787392
20,00	20	19,8	104	41	55	0,40	4	SCM770-2000Z04R-F0040HB-HP920	30787393
25,00	25	24,5	136	68	80	0,50	4	SCM770-2500Z04R-F0050HB-HP920	30787394

Design with small chamfer | Preferred series in stock

6,00	6	5,8	57	13	20	0,10	4	SCM770-0600Z04R-F0010HB-HP920	31243605
8,00	8	7,8	63	21	25	0,10	4	SCM770-0800Z04R-F0010HB-HP920	31243606
10,00	10	9,8	72	22	30	0,10	4	SCM770-1000Z04R-F0010HB-HP920	31243608
12,00	12	11,8	83	26	36	0,10	4	SCM770-1200Z04R-F0010HB-HP920	31243609
14,00	14	13,8	83	26	36	0,10	4	SCM770-1400Z04R-F0010HB-HP920	31243610
16,00	16	15,8	92	36	42	0,10	4	SCM770-1600Z04R-F0010HB-HP920	31243611
20,00	20	19,8	104	41	55	0,10	4	SCM770-2000Z04R-F0010HB-HP920	31243612

Configurable features



Shank form:
Shank form: HA



Specification:
SCM770-0250Z04R-F0005[shank form]-HP920

Example:

SCM770-0250Z04R-F0005HA-HP920

Shank form HA

Dimensions in mm.

* Design without neck.

For cutting data recommendations, see end of chapter.

Special designs and other coatings available upon request.

OptiMill®-Uni-HPC-Plus

Shoulder milling cutter, long design with neck, design with corner radius
SCM770

Design:

Diameter of milling cutter: 2.50 - 25.00 mm
Cutting material: HP920
Number of cutting edges: 4
Helix angle: 36°/38°
Special features: Unequal spacing, rounding the cutting edge

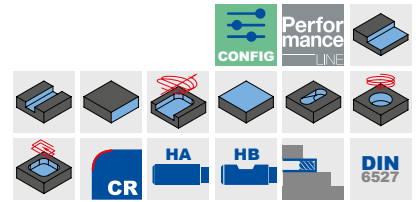
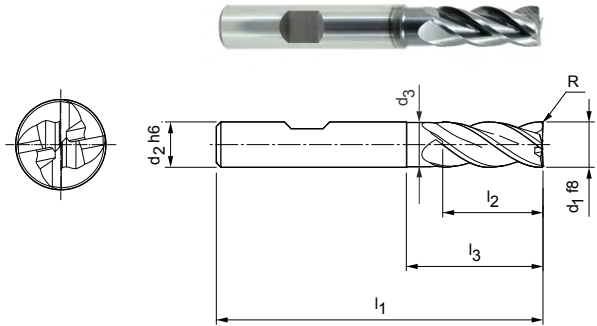

Design with radius | Preferred series in stock

Dimensions							z	Specification	Order no.
d1 f8	d2 h6	d3	l1	l2	l3	R			
4,00*	6	-	57	11	-	0,4	4	SCM770-0400Z04R-R0040HB-HP920	30787434
4,00*	6	-	57	11	-	0,5	4	SCM770-0400Z04R-R0050HB-HP920	30787435
4,00*	6	-	57	11	-	1	4	SCM770-0400Z04R-R0100HB-HP920	30787436
5,00*	6	-	57	13	-	0,5	4	SCM770-0500Z04R-R0050HB-HP920	30787437
5,00*	6	-	57	13	-	1	4	SCM770-0500Z04R-R0100HB-HP920	30787438
6,00	6	5,8	57	13	20	0,5	4	SCM770-0600Z04R-R0050HB-HP920	30787439
6,00	6	5,8	57	13	20	1	4	SCM770-0600Z04R-R0100HB-HP920	30787440
6,00	6	5,8	57	13	20	1,5	4	SCM770-0600Z04R-R0150HB-HP920	30787441
6,00	6	5,8	57	13	20	2	4	SCM770-0600Z04R-R0200HB-HP920	30787442
8,00	8	7,8	63	21	25	0,5	4	SCM770-0800Z04R-R0050HB-HP920	30787443
8,00	8	7,8	63	21	25	1	4	SCM770-0800Z04R-R0100HB-HP920	30787444
8,00	8	7,8	63	21	25	1,5	4	SCM770-0800Z04R-R0150HB-HP920	30787445
8,00	8	7,8	63	21	25	2	4	SCM770-0800Z04R-R0200HB-HP920	30787446
8,00	8	7,8	63	21	25	2,5	4	SCM770-0800Z04R-R0250HB-HP920	30787447
8,00	8	7,8	63	21	25	3	4	SCM770-0800Z04R-R0300HB-HP920	30787448
10,00	10	9,8	72	22	30	0,5	4	SCM770-1000Z04R-R0050HB-HP920	30787449
10,00	10	9,8	72	22	30	1	4	SCM770-1000Z04R-R0100HB-HP920	30787450
10,00	10	9,8	72	22	30	1,5	4	SCM770-1000Z04R-R0150HB-HP920	30787451
10,00	10	9,8	72	22	30	2	4	SCM770-1000Z04R-R0200HB-HP920	30787452
10,00	10	9,8	72	22	30	2,5	4	SCM770-1000Z04R-R0250HB-HP920	30787453
10,00	10	9,8	72	22	30	3	4	SCM770-1000Z04R-R0300HB-HP920	30787454
12,00	12	11,8	83	26	36	0,5	4	SCM770-1200Z04R-R0050HB-HP920	30787455
12,00	12	11,8	83	26	36	1	4	SCM770-1200Z04R-R0100HB-HP920	30787456
12,00	12	11,8	83	26	36	1,5	4	SCM770-1200Z04R-R0150HB-HP920	30787457
12,00	12	11,8	83	26	36	2	4	SCM770-1200Z04R-R0200HB-HP920	30787458
12,00	12	11,8	83	26	36	2,5	4	SCM770-1200Z04R-R0250HB-HP920	30787459
12,00	12	11,8	83	26	36	3	4	SCM770-1200Z04R-R0300HB-HP920	30787460
12,00	12	11,8	83	26	36	4	4	SCM770-1200Z04R-R0400HB-HP920	30787461
16,00	16	15,8	92	36	42	0,5	4	SCM770-1600Z04R-R0050HB-HP920	30787462
16,00	16	15,8	92	36	42	1	4	SCM770-1600Z04R-R0100HB-HP920	30787463
16,00	16	15,8	92	36	42	2	4	SCM770-1600Z04R-R0200HB-HP920	30787464
16,00	16	15,8	92	36	42	2,5	4	SCM770-1600Z04R-R0250HB-HP920	30787465
16,00	16	15,8	92	36	42	3	4	SCM770-1600Z04R-R0300HB-HP920	30787466
16,00	16	15,8	92	36	42	4	4	SCM770-1600Z04R-R0400HB-HP920	30787467
20,00	20	19,8	104	41	52	1	4	SCM770-2000Z04R-R0100HB-HP920	30787468

Design with radius | Preferred series in stock

Dimensions							z	Specification	Order no.
d ₁ f8	d ₂ h6	d ₃	l ₁	l ₂	l ₃	R			
20,00	20	19,8	104	41	52	2	4	SCM770-2000Z04R-R0200HB-HP920	30787469
20,00	20	19,8	104	41	52	3	4	SCM770-2000Z04R-R0300HB-HP920	30787470
20,00	20	19,8	104	41	52	4	4	SCM770-2000Z04R-R0400HB-HP920	30787471

Configurable features



Shank form:
Shank form: HA



Specification:
SCM770-0400Z04R-R0040[shank form]-HP920

Example:

SCM770-0400Z04R-R0040HA-HP920

Shank form HA

Dimensions in mm.

* Design without neck.

For cutting data recommendations, see end of chapter.

Special designs and other coatings available upon request.

OptiMill®-Uni-HPC-Plus

Shoulder milling cutter, overlong design with neck, design with chamfer
SCM720

Design:

Diameter of milling cutter: 5.00 - 25.00 mm
Cutting material: HP920
Number of cutting edges: 4
Helix angle: 36°/38°
Special features: Unequal spacing, rounding the cutting edge

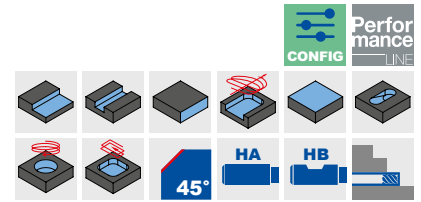
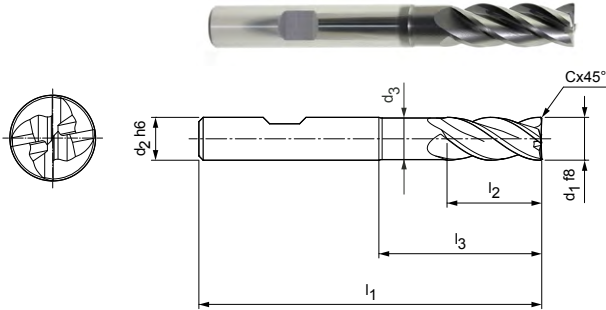

Preferred series in stock

Dimensions							z	Specification	Order no.
d1 f8	d2 h6	d3	l1	l2	l3	Cx45°			
6,00	6	5,8	62	13	25	0,12	4	SCM720-0600Z04R-F0012HB-HP920	30652409
8,00	8	7,7	68	21	30	0,16	4	SCM720-0800Z04R-F0016HB-HP920	30652410
10,00	10	9,7	80	22	38	0,20	4	SCM720-1000Z04R-F0020HB-HP920	30652411
12,00	12	11,6	93	26	46	0,24	4	SCM720-1200Z04R-F0024HB-HP920	30652412
14,00	14	13,6	99	26	52	0,28	4	SCM720-1400Z04R-F0028HB-HP920	30652413
16,00	16	15,5	108	36	58	0,32	4	SCM720-1600Z04R-F0032HB-HP920	30652414
18,00	18	17,5	117	36	67	0,36	4	SCM720-1800Z04R-F0036HB-HP920	30652415
20,00	20	19,5	126	41	74	0,40	4	SCM720-2000Z04R-F0040HB-HP920	30652416
25,00	25	24	150	50	92	0,50	4	SCM720-2500Z04R-F0050HB-HP920	30652417

Available on request

5,00	6	4,8	62	13	24	0,10	4	SCM720-0500Z04R-F0010HB-HP920	30652408
------	---	-----	----	----	----	------	---	-------------------------------	----------

Configurable features



Shank form:
Shank form: HA



Specification:
SCM720-0600Z04R-F0012[shank form]-HP920

Example:

SCM720-0600Z04R-F0012HA-HP920

Shank form HA

Dimensions in mm.

For cutting data recommendations, see end of chapter.

Special designs and other coatings available upon request.

OptiMill®-Uni-HPC-Plus

Shoulder milling cutter, overlong design with neck, design with corner radius
SCM720

Design:

Diameter of milling cutter: 4.00 - 25.00 mm
Cutting material: HP920
Number of cutting edges: 4
Helix angle: 36°/38°
Special features: Unequal spacing, rounding the cutting edge

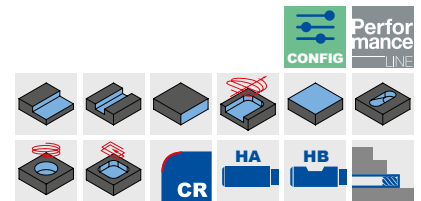
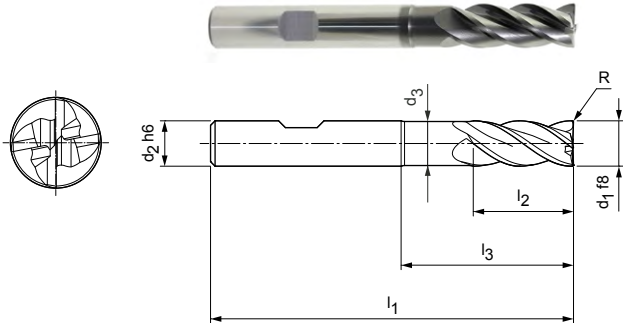

Preferred series in stock

Dimensions							z	Specification	Order no.
d1 f8	d2 h6	d3	l1	l2	l3	R			
4,00	6	3,8	62	11	22	0,5	4	SCM720-0400Z04R-R0050HB-HP920	31046163
4,00	6	3,8	62	11	22	1	4	SCM720-0400Z04R-R0100HB-HP920	31046164
5,00	6	4,8	62	13	24	0,5	4	SCM720-0500Z04R-R0050HB-HP920	31046165
5,00	6	4,8	62	13	24	1	4	SCM720-0500Z04R-R0100HB-HP920	31046166
6,00	6	5,8	62	13	25	0,5	4	SCM720-0600Z04R-R0050HB-HP920	31046167
6,00	6	5,8	62	13	25	1	4	SCM720-0600Z04R-R0100HB-HP920	31046168
6,00	6	5,8	62	13	25	2	4	SCM720-0600Z04R-R0200HB-HP920	31046169
8,00	8	7,7	68	21	30	1	4	SCM720-0800Z04R-R0100HB-HP920	31046170
8,00	8	7,7	68	21	30	2	4	SCM720-0800Z04R-R0200HB-HP920	31046171
10,00	10	9,7	80	22	38	0,5	4	SCM720-1000Z04R-R0050HB-HP920	31046172
10,00	10	9,7	80	22	38	1	4	SCM720-1000Z04R-R0100HB-HP920	31046173
10,00	10	9,7	80	22	38	1,5	4	SCM720-1000Z04R-R0150HB-HP920	31046174
10,00	10	9,7	80	22	38	2	4	SCM720-1000Z04R-R0200HB-HP920	31046175
10,00	10	9,7	80	22	38	3	4	SCM720-1000Z04R-R0300HB-HP920	31046176
12,00	12	11,6	93	26	46	0,5	4	SCM720-1200Z04R-R0050HB-HP920	31046177
12,00	12	11,6	93	26	46	1	4	SCM720-1200Z04R-R0100HB-HP920	31046178
12,00	12	11,6	93	26	46	1,5	4	SCM720-1200Z04R-R0150HB-HP920	31046179
12,00	12	11,6	93	26	46	2	4	SCM720-1200Z04R-R0200HB-HP920	31046180
12,00	12	11,6	93	26	46	3	4	SCM720-1200Z04R-R0300HB-HP920	31046181
16,00	16	15,5	108	36	58	0,5	4	SCM720-1600Z04R-R0050HB-HP920	31046182
16,00	16	15,5	108	36	58	1	4	SCM720-1600Z04R-R0100HB-HP920	31046183
16,00	16	15,5	108	36	58	2	4	SCM720-1600Z04R-R0200HB-HP920	31046184
16,00	16	15,5	108	36	58	4	4	SCM720-1600Z04R-R0400HB-HP920	31046185
20,00	20	19,5	126	41	74	1	4	SCM720-2000Z04R-R0100HB-HP920	31046186
20,00	20	19,5	126	41	74	2	4	SCM720-2000Z04R-R0200HB-HP920	31046187
20,00	20	19,5	126	41	74	4	4	SCM720-2000Z04R-R0400HB-HP920	31046188

Configurable features



Shank form:
Shank form: HA



Specification:
SCM720-0400Z04R-R0050[shank form]-HP920

Example:

SCM720-0400Z04R-R0050HA-HP920

Shank form HA

Dimensions in mm.

* Design without neck.

For cutting data recommendations, see end of chapter.

Special designs and other coatings available upon request.

OptiMill®-Uni-HPC-Plus

Shoulder milling cutter, extra long design with neck
SCM740

Design:

Diameter of milling cutter: 5.00 - 25.00 mm
Cutting material: HP920
Number of cutting edges: 4
Helix angle: 36°/38°
Special features: Unequal spacing, rounding the cutting edge

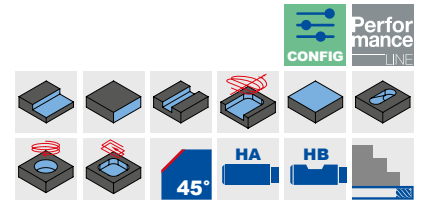
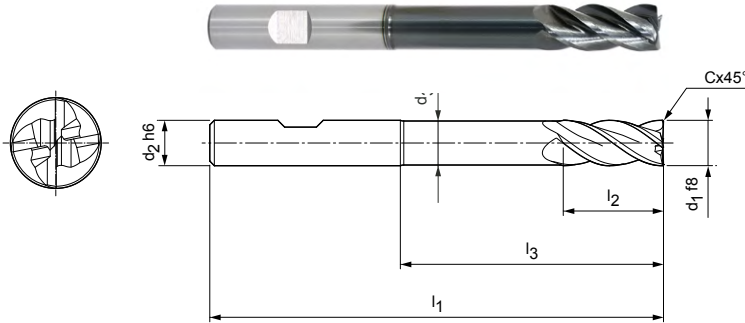

Preferred series in stock

Dimensions							z	Specification	Order no.
d1 f8	d2 h6	d3	l1	l2	l3	Cx45°			
5,00	6	4,8	80	13	41	0,10	4	SCM740-0500Z04R-F0010HB-HP920	30652418
6,00	6	5,8	80	13	42	0,12	4	SCM740-0600Z04R-F0012HB-HP920	30652419
8,00	8	7,7	100	21	62	0,16	4	SCM740-0800Z04R-F0016HB-HP920	30652420
10,00	10	9,7	100	22	58	0,20	4	SCM740-1000Z04R-F0020HB-HP920	30652421
12,00	12	11,6	120	26	73	0,24	4	SCM740-1200Z04R-F0024HB-HP920	30652422
14,00	14	13,6	120	26	73	0,28	4	SCM740-1400Z04R-F0028HB-HP920	30652423
16,00	16	15,5	150	36	100	0,32	4	SCM740-1600Z04R-F0032HB-HP920	30652424
20,00	20	19,5	150	41	98	0,40	4	SCM740-2000Z04R-F0040HB-HP920	30652426

Available on request

18,00	18	17,5	150	36	100	0,36	4	SCM740-1800Z04R-F0036HB-HP920	30652425
25,00	25	24	175	50	117	0,50	4	SCM740-2500Z04R-F0050HB-HP920	30652427

Configurable features



Shank form:
Shank form: HA



Specification:
SCM740-0500Z04R-F0010[shank form]-HP920

Example:

SCM740-0500Z04R-F0010HA-HP920

Shank form HA

Dimensions in mm.

For cutting data recommendations, see end of chapter.

Special designs and other coatings available upon request.

OptiMill®-Uni-HPC-Finish

Shoulder milling cutter, 2xD design
SCM830

Design:

Diameter of milling cutter: 4.00 - 20.00 mm
Cutting material: HP213
Number of cutting edges: 7
Helix angle: 45°
Special features: Unequal spacing

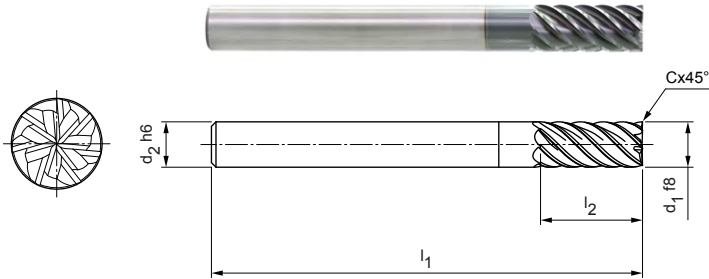

Preferred series in stock

Dimensions					z	Specification	Order no.
d ₁ f8	d ₂ h6	l ₁	l ₂	Cx45°			
4,00	6	57	11	0,04	7	SCM830-0400Z07R-F0004HA2-HP213	30936070
5,00	6	57	13	0,05	7	SCM830-0500Z07R-F0005HA2-HP213	30936071
6,00	6	57	13	0,06	7	SCM830-0600Z07R-F0006HA2-HP213	30936072
8,00	8	63	19	0,08	7	SCM830-0800Z07R-F0008HA2-HP213	30936073
10,00	10	72	22	0,10	7	SCM830-1000Z07R-F0010HA2-HP213	30936074
12,00	12	83	26	0,12	7	SCM830-1200Z07R-F0012HA2-HP213	30936076
14,00	14	83	26	0,14	7	SCM830-1400Z07R-F0014HA2-HP213	30936077
16,00	16	92	32	0,16	7	SCM830-1600Z07R-F0016HA2-HP213	30936078
20,00	20	104	41	0,20	7	SCM830-2000Z07R-F0020HA2-HP213	30936090

Available on request

18,00	18	92	32	0,18	7	SCM830-1800Z07R-F0018HA2-HP213	30936079
-------	----	----	----	------	---	--------------------------------	----------

Configurable features

Shank form:
Shank form: HB

Specification:
SCM830-0400Z07R-F0004[shank form]2-HP213

Example:

SCM830-0400Z07R-F0004**HB**2-HP213

Shank form HB

Dimensions in mm.

For cutting data recommendations, see end of chapter.

Special designs and other coatings available upon request.

OptiMill®-Uni-HPC-Finish

Shoulder milling cutter, 3xD design
SCM830

Design:

Diameter of milling cutter: 4.00 - 20.00 mm
Cutting material: HP213
Number of cutting edges: 7
Helix angle: ~ 45°
Special features: Unequal spacing

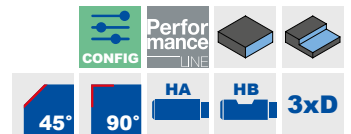
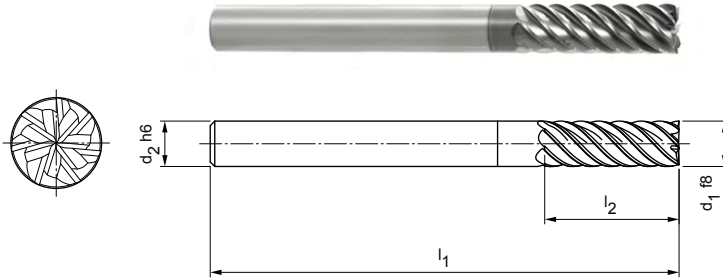

Design with chamfer | Preferred series in stock

Dimensions					z	Specification	Order no.
d ₁ f8	d ₂ h6	l ₁	l ₂	Cx45°			
4,00	6	62	16	0,04	7	SCM830-0400Z07R-F0004HA3-HP213	30936093
5,00	6	62	17	0,05	7	SCM830-0500Z07R-F0005HA3-HP213	30936094
6,00	6	62	18	0,06	7	SCM830-0600Z07R-F0006HA3-HP213	30936095
8,00	8	68	24	0,08	7	SCM830-0800Z07R-F0008HA3-HP213	30936096
10,00	10	80	30	0,10	7	SCM830-1000Z07R-F0010HA3-HP213	30936098
12,00	12	93	36	0,12	7	SCM830-1200Z07R-F0012HA3-HP213	30936099
14,00	14	99	42	0,14	7	SCM830-1400Z07R-F0014HA3-HP213	30936110
16,00	16	108	48	0,16	7	SCM830-1600Z07R-F0016HA3-HP213	30936111
20,00	20	126	60	0,20	7	SCM830-2000Z07R-F0020HA3-HP213	30936114

Design with chamfer | Available on request

18,00	18	117	54	0,18	7	SCM830-1800Z07R-F0018HA3-HP213	30936112
-------	----	-----	----	------	---	--------------------------------	----------

Design with sharp edge | Preferred series in stock

4,00	6	62	16	-	7	SCM830-0400Z07R-S-HA3-HP213	31046210
5,00	6	62	17	-	7	SCM830-0500Z07R-S-HA3-HP213	31046211
6,00	6	62	18	-	7	SCM830-0600Z07R-S-HA3-HP213	31046212
8,00	8	68	24	-	7	SCM830-0800Z07R-S-HA3-HP213	31046213
10,00	10	80	30	-	7	SCM830-1000Z07R-S-HA3-HP213	31046214
12,00	12	93	36	-	7	SCM830-1200Z07R-S-HA3-HP213	31046215
14,00	14	99	42	-	7	SCM830-1400Z07R-S-HA3-HP213	31046216
16,00	16	108	48	-	7	SCM830-1600Z07R-S-HA3-HP213	31046217
20,00	20	126	60	-	7	SCM830-2000Z07R-S-HA3-HP213	31046219

Design with sharp edge | Available on request

18,00	18	117	54	-	7	SCM830-1800Z07R-S-HA3-HP213	31046218
-------	----	-----	----	---	---	-----------------------------	----------

Configurable features



Shank form:
Shank form: HB



Specification:
SCM830-0400Z07R-F0004[shank form]3-HP213

Example:

SCM830-0400Z07R-F0004HB3-HP213

Shank form HB

Dimensions in mm.

For cutting data recommendations, see end of chapter.
Special designs and other coatings available upon request.

OptiMill®-Uni-HPC-Finish

Shoulder milling cutter, 4xD design
SCM830

Design:

Diameter of milling cutter: 6.00 – 25.00 mm
Cutting material: HP213
Number of cutting edges: 7
Helix angle: 45°
Special features: Unequal spacing

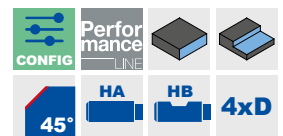
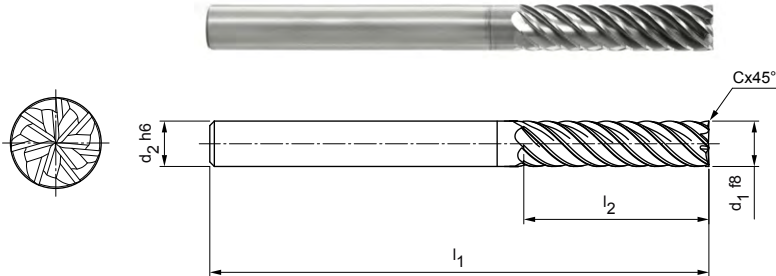

Preferred series in stock

Dimensions					z	Specification	Order no.
d ₁ f8	d ₂ h6	l ₁	l ₂	Cx45°			
6,00	6	66	24	0,06	7	SCM830-0600Z07R-F0006HA4-HP209	30936116
8,00	8	74	32	0,08	7	SCM830-0800Z07R-F0008HA4-HP209	30936117
10,00	10	89	40	0,10	7	SCM830-1000Z07R-F0010HA4-HP209	30936118
12,00	12	100	48	0,12	7	SCM830-1200Z07R-F0012HA4-HP209	30936119
14,00	14	108	56	0,14	7	SCM830-1400Z07R-F0014HA4-HP209	30936131
16,00	16	123	64	0,16	7	SCM830-1600Z07R-F0016HA4-HP209	30936132
20,00	20	140	80	0,20	7	SCM830-2000Z07R-F0020HA4-HP209	30936134

Available on request

18,00	18	130	72	0,18	7	SCM830-1800Z07R-F0018HA4-HP209	30936133
25,00	25	170	100	0,25	7	SCM830-2500Z07R-F0025HA4-HP209	30936136

Configurable features

Shank form:
Shank form: HB

Specification:
SCM830-0600Z07R-F0006[shank form]4-HP209

Example:

SCM830-0600Z07R-F0006HB4-HP209

Shank form HB

Dimensions in mm.

For cutting data recommendations, see end of chapter.

Special designs and other coatings available upon request.

OptiMill®-Uni-HPC-Finish

Shoulder milling cutter, 5xD design
SCM830

Design:

Diameter of milling cutter: 8.00 - 25.00 mm
Cutting material: HP209
Number of cutting edges: 7
Helix angle: ~ 45°
Special features: Unequal spacing

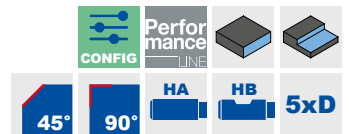
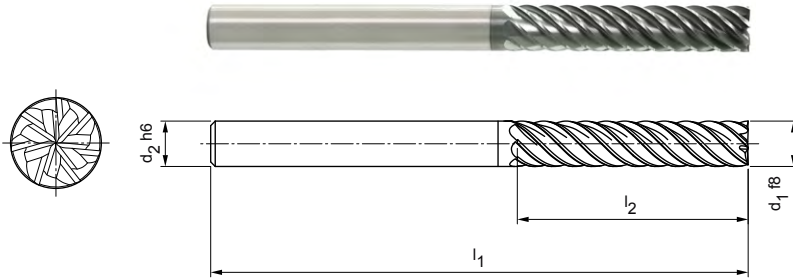

Design with chamfer | Preferred series in stock

Dimensions					z	Specification	Order no.
d ₁ f8	d ₂ h6	l ₁	l ₂	Cx45°			
8,00	8	81	40	0,08	7	SCM830-0800Z07R-F0008HA5-HP209	30936137
10,00	10	96	50	0,10	7	SCM830-1000Z07R-F0010HA5-HP209	30936138
12,00	12	112	60	0,12	7	SCM830-1200Z07R-F0012HA5-HP209	30936139
14,00	14	122	70	0,14	7	SCM830-1400Z07R-F0014HA5-HP209	30936150
16,00	16	136	80	0,16	7	SCM830-1600Z07R-F0016HA5-HP209	30936151
20,00	20	160	100	0,20	7	SCM830-2000Z07R-F0020HA5-HP209	30936153

Design with chamfer | Available on request

18,00	18	147	90	0,18	7	SCM830-1800Z07R-F0018HA5-HP209	30936152
25,00	25	195	125	0,25	7	SCM830-2500Z07R-F0025HA5-HP209	30936154

Edge design with sharp edge | Preferred series available from stock

8,00	8	81	40	-	7	SCM830-0800Z07R-S-HA5-HP209	31046449
10,00	10	96	50	-	7	SCM830-1000Z07R-S-HA5-HP209	31046470
12,00	12	112	60	-	7	SCM830-1200Z07R-S-HA5-HP209	31046471
14,00	14	122	70	-	7	SCM830-1400Z07R-S-HA5-HP209	31046473
16,00	16	136	80	-	7	SCM830-1600Z07R-S-HA5-HP209	31046474
20,00	20	160	100	-	7	SCM830-2000Z07R-S-HA5-HP209	31046476

Design with sharp edge | Available on request

18,00	18	147	90	-	7	SCM830-1800Z07R-S-HA5-HP209	31046475
25,00	25	195	125	-	7	SCM830-2500Z07R-S-HA5-HP209	31046477

Configurable features



Shank form:
Shank form: HB



Specification:
SCM830-0800Z07R-F0008[shank form]5-HP209

Example:

SCM830-0800Z07R-F0008HB5-HP209

Shank form HB

Dimensions in mm.

For cutting data recommendations, see end of chapter.

Special designs and other coatings available upon request.

OptiMill®-Uni-Wave

Shoulder milling cutter, short design
SCM890

Design:

Diameter of milling cutter: 4.00 - 25.00 mm
Cutting material: HP723
Number of cutting edges: 5
Helix angle: ~ 41.5°
Special features: Unequal spacing, newly developed roughing profile

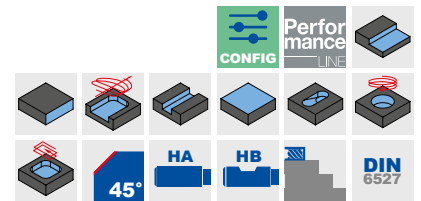
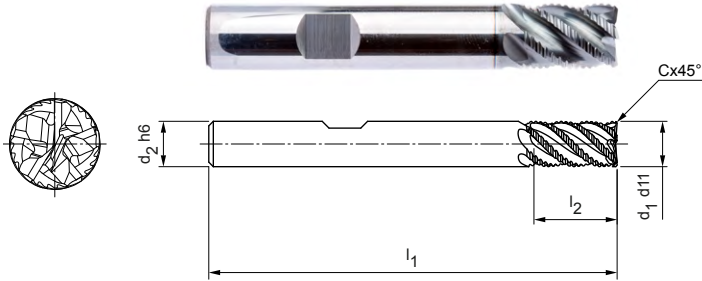

Preferred series in stock

Dimensions					z	Specification	Order no.
d ₁ d ₁₁	d ₂ h ₆	l ₁	l ₂	Cx45°			
4,00	6	54	8	0,20	5	SCM890-0400Z05R-F0020HB-HP723	30917921
5,00	6	54	9	0,25	5	SCM890-0500Z05R-F0025HB-HP723	30917923
6,00	6	54	10	0,30	5	SCM890-0600Z05R-F0030HB-HP723	30917924
7,00	8	58	11	0,35	5	SCM890-0700Z05R-F0035HB-HP723	30917925
8,00	8	58	12	0,40	5	SCM890-0800Z05R-F0040HB-HP723	30917926
9,00	10	66	13	0,45	5	SCM890-0900Z05R-F0045HB-HP723	30917927
10,00	10	66	14	0,50	5	SCM890-1000Z05R-F0050HB-HP723	30917928
12,00	12	73	16	0,60	5	SCM890-1200Z05R-F0060HB-HP723	30917929
14,00	14	75	18	0,70	5	SCM890-1400Z05R-F0070HB-HP723	30917930
16,00	16	82	22	0,80	5	SCM890-1600Z05R-F0080HB-HP723	30917931
20,00	20	92	26	1,00	5	SCM890-2000Z05R-F0100HB-HP723	30917933
25,00	25	105	32	1,25	5	SCM890-2500Z05R-F0125HB-HP723	30917934

Available on request

18,00	18	84	24	0,9	5	SCM890-1800Z05R-F0090HB-HP723	30917932
-------	----	----	----	-----	---	-------------------------------	----------

Configurable features



Shank form:
Shank form: HA



Specification:
SCM890-0400Z05R-F0020[shank form]-HP723

Example:

SCM890-0400Z05R-F0020HA-HP723

Shank form HA

Dimensions in mm.

For cutting data recommendations, see end of chapter.

Special designs and other coatings available upon request.

OptiMill®-Uni-Wave

Shoulder milling cutter, long design with neck
SCM880

Design:

Diameter of milling cutter: 4.00 - 25.00 mm
Cutting material: HP723
Number of cutting edges: 5
Helix angle: ~ 41.5°
Special features: Unequal spacing, newly developed roughing profile

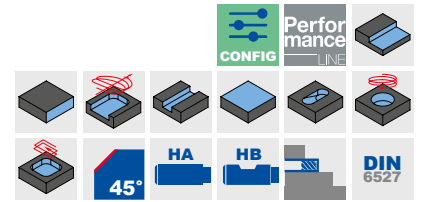
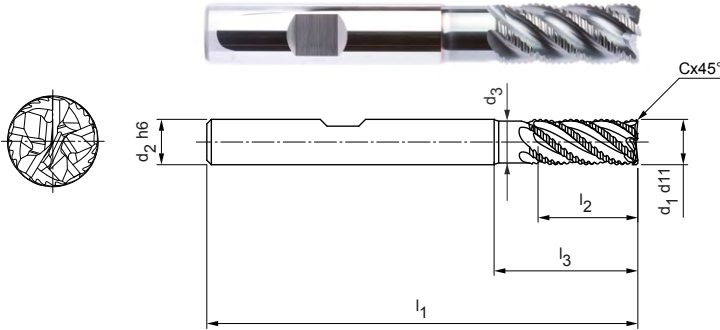

Preferred series in stock

Dimensions							z	Specification	Order no.
d ₁ d ₁₁	d ₂ h ₆	d ₃	l ₁	l ₂	l ₃	Cx45°			
4,00	6	3,7	57	11	19	0,20	5	SCM880-0400Z05R-F0020HB-HP723	30917935
5,00	6	4,6	57	13	19	0,25	5	SCM880-0500Z05R-F0025HB-HP723	30917936
6,00	6	5,6	57	13	19	0,30	5	SCM880-0600Z05R-F0030HB-HP723	30917937
7,00	8	6,5	63	16	25	0,35	5	SCM880-0700Z05R-F0035HB-HP723	30917938
8,00	8	7,4	63	19	25	0,40	5	SCM880-0800Z05R-F0040HB-HP723	30917939
9,00	10	8,3	72	19	30	0,45	5	SCM880-0900Z05R-F0045HB-HP723	30917940
10,00	10	9,3	72	22	30	0,50	5	SCM880-1000Z05R-F0050HB-HP723	30917941
12,00	12	11,1	83	26	36	0,60	5	SCM880-1200Z05R-F0060HB-HP723	30917942
14,00	14	13	83	26	36	0,70	5	SCM880-1400Z05R-F0070HB-HP723	30917943
16,00	16	14,8	92	32	42	0,80	5	SCM880-1600Z05R-F0080HB-HP723	30917944
20,00	20	18,5	104	38	52	1,00	5	SCM880-2000Z05R-F0100HB-HP723	30917946
25,00	25	23,1	125	50	65	1,25	5	SCM880-2500Z05R-F0125HB-HP723	30917947

Available on request

18,00	18	16,7	92	32	42	0,9	5	SCM880-1800Z05R-F0090HB-HP723	30917945
-------	----	------	----	----	----	-----	---	-------------------------------	----------

Configurable features



Shank form:
Shank form: HA



Specification:
SCM880-0400Z05R-F0020[shank form]-HP723

Example:

SCM880-0400Z05R-F0020HA-HP723

Shank form HA

Dimensions in mm.

For cutting data recommendations, see end of chapter.

Special designs and other coatings available upon request.

OptiMill®-Uni-Wave

Shoulder milling cutter, overlong design with neck
SCM900

Design:

Diameter of milling cutter: 5.00 - 25.00 mm
Cutting material: HP210
Number of cutting edges: 5
Helix angle: ~ 41.5°
Special features: Unequal spacing, newly developed roughing profile

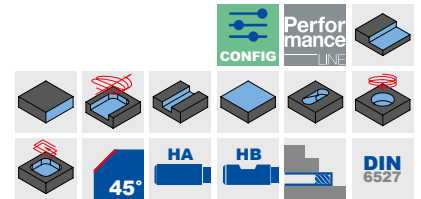
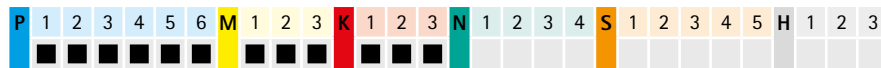
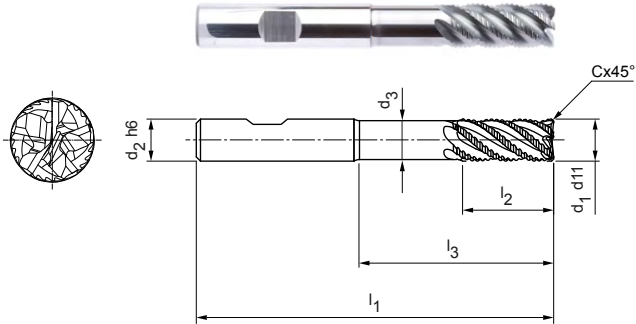

Preferred series in stock

Dimensions							z	Specification	Order no.
d ₁ d ₁₁	d ₂ h ₆	d ₃	l ₁	l ₂	l ₃	Cx45°			
5,00	6	4,6	62	13	24	0,25	5	SCM900-0500Z05R-F0025HB-HP210	31054574
6,00	6	5,6	62	13	25	0,30	5	SCM900-0600Z05R-F0030HB-HP210	31054575
8,00	8	7,4	68	21	30	0,40	5	SCM900-0800Z05R-F0040HB-HP210	31054576
10,00	10	9,3	80	22	38	0,50	5	SCM900-1000Z05R-F0050HB-HP210	31054577
12,00	12	11,1	93	26	46	0,60	5	SCM900-1200Z05R-F0060HB-HP210	31054578
14,00	14	13	99	26	52	0,70	5	SCM900-1400Z05R-F0070HB-HP210	31054579
16,00	16	14,8	108	36	58	0,80	5	SCM900-1600Z05R-F0080HB-HP210	31054580
20,00	20	18,5	126	41	74	1,00	5	SCM900-2000Z05R-F0100HB-HP210	31054582

Available on request

18,00	18	16,7	117	36	67	0,90	5	SCM900-1800Z05R-F0090HB-HP210	31054581
25,00	25	23,1	150	50	92	1,25	5	SCM900-2500Z05R-F0125HB-HP210	31054583

Configurable features



Shank form:
Shank form: HA



Specification:
SCM900-0500Z05R-F0025[shank form]-HP210

Example:

SCM900-0500Z05R-F0025HA-HP210

Shank form HA

Dimensions in mm.

For cutting data recommendations, see end of chapter.

Special designs and other coatings available upon request.

OptiMill®-Uni-Wave

Shoulder milling cutter, design 3xD with neck
SCM900

Design:

Diameter of milling cutter: 5.00 - 25.00 mm
Cutting material: HP210
Number of cutting edges: 5
Helix angle: ~ 42°
Special features: Unequal spacing, newly developed roughing profile

Application:

Suitable for shoulder milling up to a maximum cutting width of 0.25xD. Also suitable for trochoidal milling.

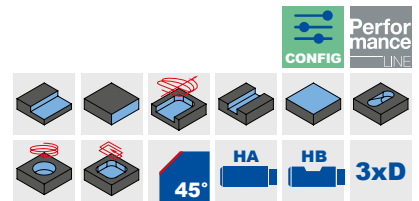
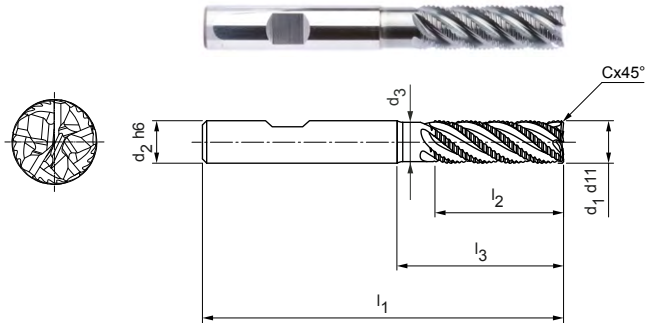

Preferred series in stock

Dimensions							z	Specification	Order no.
d1 d11	d2 h6	d3	l1	l2	l3	Cx45°			
5,00	6	4,6	62	17	24	0,25	5	SCM900-0500Z05R-F0025HB3-HP210	31054554
6,00	6	5,6	62	18	25	0,30	5	SCM900-0600Z05R-F0030HB3-HP210	31054555
8,00	8	7,7	68	24	30	0,40	5	SCM900-0800Z05R-F0040HB3-HP210	31054556
10,00	10	9,3	80	30	35	0,50	5	SCM900-1000Z05R-F0050HB3-HP210	31054557
12,00	12	11,1	93	36	45	0,60	5	SCM900-1200Z05R-F0060HB3-HP210	31054558
14,00	14	13	99	42	50	0,70	5	SCM900-1400Z05R-F0070HB3-HP210	31054559
16,00	16	14,8	108	48	55	0,80	5	SCM900-1600Z05R-F0080HB3-HP210	31054570
20,00	20	18,5	126	60	70	1,00	5	SCM900-2000Z05R-F0100HB3-HP210	31054572

Available on request

18,00	18	16,7	117	54	67	0,90	5	SCM900-1800Z05R-F0090HB3-HP210	31054571
25,00	25	21,1	150	75	92	1,25	5	SCM900-2500Z05R-F0125HB3-HP210	31054573

Configurable features

Shank form:
Shank form: HA

Specification:
SCM900-0500Z05R-F0025[shank form]3-HP210

Example:

SCM900-0500Z05R-F0025HA3-HP210

Shank form HA

Dimensions in mm.

For cutting data recommendations, see end of chapter.

Special designs and other coatings available upon request.

OptiMill®-Uni-Wave

Shoulder milling cutter, extra long design with neck
SCM910

Design:

Diameter of milling cutter: 6.00 - 20.00 mm
Cutting material: HP723
Number of cutting edges: 5
Helix angle: ~ 42°
Special features: Unequal spacing, newly developed roughing profile

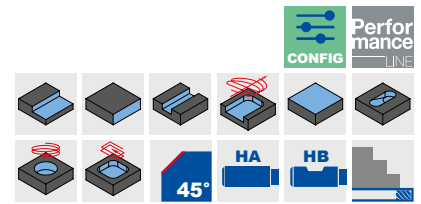
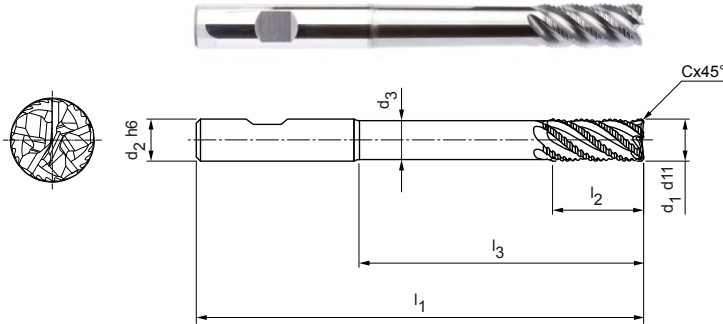

Preferred series in stock

Dimensions							z	Specification	Order no.
d ₁ d ₁₁	d ₂ h ₆	d ₃	l ₁	l ₂	l ₃	Cx45°			
6,00	6	5,4	80	13	42	0,30	5	SCM910-0600Z05R-F0030HB-HP723	31096360
8,00	8	7,2	100	21	62	0,40	5	SCM910-0800Z05R-F0040HB-HP723	31096362
10,00	10	9	100	22	58	0,50	5	SCM910-1000Z05R-F0050HB-HP723	31096363
12,00	12	10,8	120	26	73	0,60	5	SCM910-1200Z05R-F0060HB-HP723	31096364
16,00	16	14,4	150	36	100	0,80	5	SCM910-1600Z05R-F0080HB-HP723	31096365
20,00	20	18	150	41	98	1,00	5	SCM910-2000Z05R-F0100HB-HP723	31096366

Configurable features



Shank form:
Shank form: HA



Specification:
SCM910-0600Z05R-F0030[shank form]-HP723

Example:

SCM910-0600Z05R-F0030HA-HP723

Shank form HA

Dimensions in mm.

For cutting data recommendations, see end of chapter.

Special designs and other coatings available upon request.

OptiMill®-Uni-HPC-Pocket

Shoulder milling cutter, short design
SCM840

Design:

Diameter of milling cutter: 3.80 – 20.00 mm
Cutting material: HP920
Number of cutting edges: 3
Helix angle: ~ 42°
Special features: Face geometry with integrated drill tip

Application:

Perfect for inclined plunging up to 45°, in helix milling and grooving.

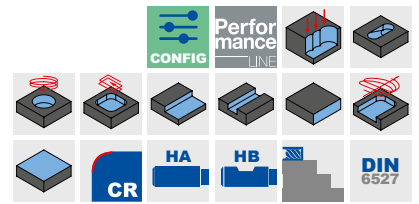
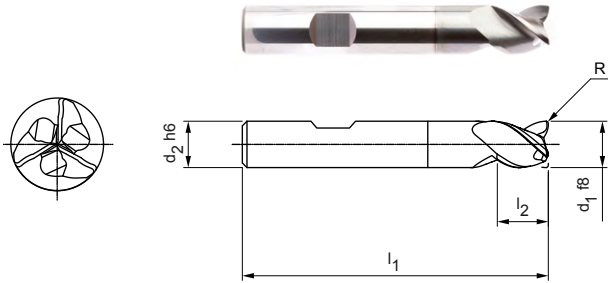

Preferred series in stock

Dimensions						z	Specification	Order no.
d ₁ f8	d ₂ h6	l ₁	l ₂	l ₅	R*			
3,80	6	54	5	10,5	0,12	3	SCM840-0380Z03R-R0012HB-HP920	31031129
4,00	6	54	5	10,5	0,12	3	SCM840-0400Z03R-R0012HB-HP920	31031140
4,80	6	54	6	12,5	0,2	3	SCM840-0480Z03R-R0020HB-HP920	31031141
5,00	6	54	6	12,5	0,2	3	SCM840-0500Z03R-R0020HB-HP920	31031142
5,70	6	54	7	14,5	0,2	3	SCM840-0570Z03R-R0020HB-HP920	30965832
6,00	6	54	7	-	0,2	3	SCM840-0600Z03R-R0020HB-HP920	30965833
6,70	8	58	8	16,5	0,2	3	SCM840-0670Z03R-R0020HB-HP920	30965834
7,00	8	58	8	17	0,2	3	SCM840-0700Z03R-R0020HB-HP920	30965835
7,70	8	58	9	18,5	0,2	3	SCM840-0770Z03R-R0020HB-HP920	30965836
8,00	8	58	9	-	0,2	3	SCM840-0800Z03R-R0020HB-HP920	30965837
8,70	10	66	10	20,5	0,32	3	SCM840-0870Z03R-R0032HB-HP920	30965838
9,00	10	66	10	21	0,32	3	SCM840-0900Z03R-R0032HB-HP920	30965839
9,70	10	66	11	22,5	0,32	3	SCM840-0970Z03R-R0032HB-HP920	30965840
10,00	10	66	11	-	0,32	3	SCM840-1000Z03R-R0032HB-HP920	30953712
11,70	12	73	12	24,5	0,32	3	SCM840-1170Z03R-R0032HB-HP920	30965841
12,00	12	73	12	-	0,32	3	SCM840-1200Z03R-R0032HB-HP920	30948678
13,70	14	75	14	26,5	0,32	3	SCM840-1370Z03R-R0032HB-HP920	30965842
14,00	14	75	14	-	0,32	3	SCM840-1400Z03R-R0032HB-HP920	30965843
15,50	16	82	16	30	0,32	3	SCM840-1550Z03R-R0032HB-HP920	30965844
16,00	16	82	16	-	0,32	3	SCM840-1600Z03R-R0032HB-HP920	30965845
17,50	18	84	18	32	0,32	3	SCM840-1750Z03R-R0032HB-HP920	30965846
19,50	20	92	20	38	0,5	3	SCM840-1950Z03R-R0050HB-HP920	30965848
20,00	20	92	20	-	0,5	3	SCM840-2000Z03R-R0050HB-HP920	30965849

* Corner radius especially for feather key milling according to DIN 6885.

Available on request

18,00	18	84	18	-	0,32	3	SCM840-1800Z03R-R0032HB-HP920	30965847
-------	----	----	----	---	------	---	-------------------------------	----------

Configurable features



Shank form:
Shank form: HA



Specification:
SCM840-0380Z03R-R0012[shank form]-HP920

Example:

SCM840-0380Z03R-R0012HA-HP920



Dimensions in mm.

For cutting data recommendations, see end of chapter.

Special designs and other coatings available upon request.



OptiMill®-Uni-HPC-Pocket

Shoulder milling cutter, long design with neck
SCM810

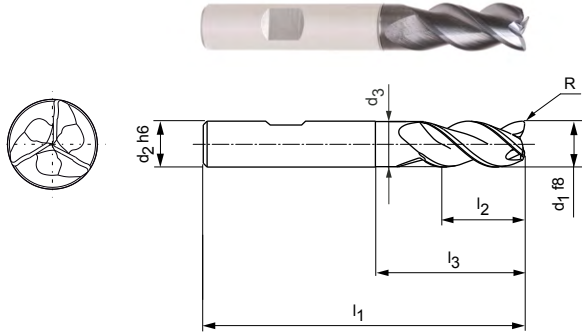

Design:

Diameter of milling cutter: 3.80 - 20.00 mm
Cutting material: HP920
Number of cutting edges: 3
Helix angle: ~ 42°
Special features: Face geometry with integrated drill tip

Application:

Perfect for inclined plunging up to 45°, in helix milling and grooving.

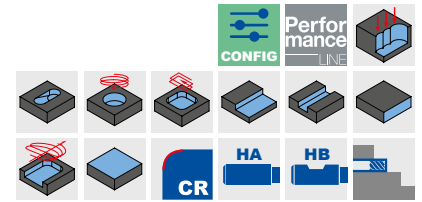

Preferred series in stock

Dimensions							z	Specification	Order no.
d1 f8	d2 h6	d3	l1	l2	l3	R			
3,80	6	3,6	57	10	13	0,19	3	SCM810-0380Z03R-R0019HB-HP920	31031147
4,00	6	3,8	57	11	13	0,2	3	SCM810-0400Z03R-R0020HB-HP920	31031148
4,80	6	4,6	57	11	15,5	0,24	3	SCM810-0480Z03R-R0024HB-HP920	31031149
5,00	6	4,8	57	13	15,5	0,25	3	SCM810-0500Z03R-R0025HB-HP920	31031150
5,70	6	5,5	57	13	19	0,29	3	SCM810-0570Z03R-R0029HB-HP920	30788023
6,00	6	5,8	57	13	19	0,3	3	SCM810-0600Z03R-R0030HB-HP920	30788024
6,70	8	6,5	63	16	25	0,34	3	SCM810-0670Z03R-R0034HB-HP920	30788025
7,00	8	6,8	63	16	25	0,35	3	SCM810-0700Z03R-R0035HB-HP920	30788026
7,70	8	7,5	63	19	25	0,39	3	SCM810-0770Z03R-R0039HB-HP920	30788027
8,00	8	7,8	63	19	25	0,4	3	SCM810-0800Z03R-R0040HB-HP920	30788028
8,70	10	8,5	72	22	30	0,44	3	SCM810-0870Z03R-R0044HB-HP920	30788029
9,00	10	8,8	72	22	30	0,45	3	SCM810-0900Z03R-R0045HB-HP920	30788030
9,70	10	9,5	72	22	30	0,49	3	SCM810-0970Z03R-R0049HB-HP920	30788031
10,00	10	9,8	72	22	30	0,5	3	SCM810-1000Z03R-R0050HB-HP920	30788032
11,70	12	11,5	83	26	36	0,59	3	SCM810-1170Z03R-R0059HB-HP920	30788033
12,00	12	11,8	83	26	36	0,6	3	SCM810-1200Z03R-R0060HB-HP920	30788034
13,70	14	13,5	83	26	36	0,69	3	SCM810-1370Z03R-R0069HB-HP920	30788035
14,00	14	13,8	83	26	36	0,7	3	SCM810-1400Z03R-R0070HB-HP920	30788036
15,50	16	15,3	92	31	42	0,78	3	SCM810-1550Z03R-R0078HB-HP920	30788037
16,00	16	15,8	92	31	42	0,8	3	SCM810-1600Z03R-R0080HB-HP920	30788038
17,50	18	17,3	92	31	42	0,88	3	SCM810-1750Z03R-R0088HB-HP920	30788039
18,00	18	17,8	92	31	42	0,9	3	SCM810-1800Z03R-R0090HB-HP920	30788040
19,50	20	19,3	104	41	52	0,98	3	SCM810-1950Z03R-R0098HB-HP920	30788041
20,00	20	19,8	104	41	52	1	3	SCM810-2000Z03R-R0100HB-HP920	30788042

Configurable features



Shank form:
Shank form: HA



Specification:
SCM810-0380Z03R-R0019[shank form]-HP920

Example:

SCM810-0380Z03R-R0019HA-HP920

Shank form HA

Dimensions in mm.

For cutting data recommendations, see end of chapter.

Special designs and other coatings available upon request.

OptiMill®-Uni-HPC-Pocket

Shoulder milling cutter, overlong design with neck
SCM800

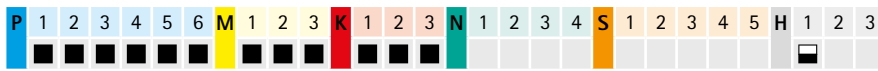
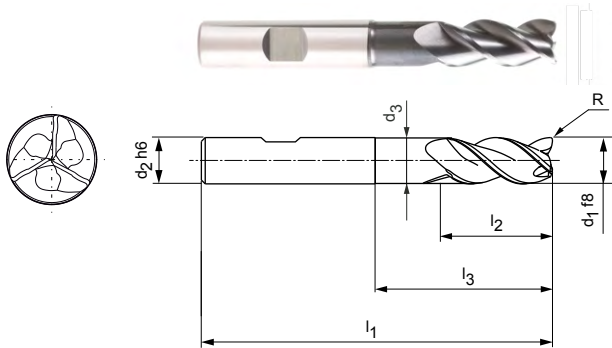

Design:

Diameter of milling cutter: 5.00 - 20.00 mm
Cutting material: HP920
Number of cutting edges: 3
Helix angle: ~ 42°
Special features: Face geometry with integrated drill tip

Application:

Perfect for inclined plunging up to 45°, in helix milling and grooving.

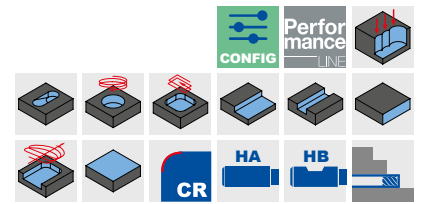

Preferred series in stock

Dimensions							z	Specification	Order no.
d1 f8	d2 h6	d3	l1	l2	l3	R			
5,00	6	4,8	62	13	24	0,25	3	SCM800-0500Z03R-R0025HB-HP920	31031146
5,70	6	5,5	62	13	24	0,29	3	SCM800-0570Z03R-R0029HB-HP920	30787957
6,00	6	5,8	62	13	24	0,3	3	SCM800-0600Z03R-R0030HB-HP920	30787958
6,70	8	6,4	68	16	30	0,34	3	SCM800-0670Z03R-R0034HB-HP920	30787959
7,00	8	6,7	68	16	30	0,35	3	SCM800-0700Z03R-R0035HB-HP920	30787960
7,70	8	7,4	68	21	30	0,39	3	SCM800-0770Z03R-R0039HB-HP920	30787961
8,00	8	7,7	68	21	30	0,4	3	SCM800-0800Z03R-R0040HB-HP920	30787962
8,70	10	8,4	80	22	38	0,44	3	SCM800-0870Z03R-R0044HB-HP920	30787963
9,00	10	8,7	80	22	38	0,45	3	SCM800-0900Z03R-R0045HB-HP920	30787964
9,70	10	9,4	80	22	38	0,49	3	SCM800-0970Z03R-R0049HB-HP920	30787965
10,00	10	9,7	80	22	38	0,5	3	SCM800-1000Z03R-R0050HB-HP920	30787966
11,70	12	11,3	93	26	46	0,59	3	SCM800-1170Z03R-R0059HB-HP920	30787967
12,00	12	11,6	93	26	46	0,6	3	SCM800-1200Z03R-R0060HB-HP920	30787968
13,70	14	13,3	99	26	52	0,69	3	SCM800-1370Z03R-R0069HB-HP920	30787969
14,00	14	13,6	99	26	52	0,7	3	SCM800-1400Z03R-R0070HB-HP920	30787970
15,50	16	15	108	36	58	0,78	3	SCM800-1550Z03R-R0078HB-HP920	30787971
16,00	16	15,5	108	36	58	0,8	3	SCM800-1600Z03R-R0080HB-HP920	30787972
17,50	18	17	117	36	67	0,88	3	SCM800-1750Z03R-R0088HB-HP920	30787973
18,00	18	17,5	117	36	67	0,9	3	SCM800-1800Z03R-R0090HB-HP920	30787974
19,50	20	19	126	41	74	0,98	3	SCM800-1950Z03R-R0098HB-HP920	30787975
20,00	20	19,5	126	41	74	1	3	SCM800-2000Z03R-R0100HB-HP920	30787976

Configurable features

Shank form:
Shank form: HA

Specification:
SCM800-0500Z03R-R0025[shank form]-HP920

Example:

SCM800-0500Z03R-R0025HA-HP920

Shank form HA

Dimensions in mm.

For cutting data recommendations, see end of chapter.

Special designs and other coatings available upon request.

OptiMill®-Alu-HPC-Pocket

Shoulder milling cutter, long design with neck
SCM850

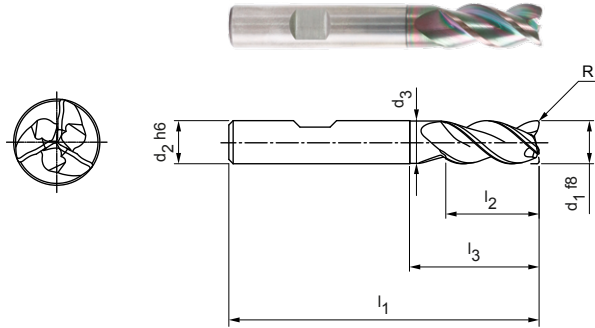

Design:

Diameter of milling cutter: 5.00 - 20.00 mm
Cutting material: HP913
Number of cutting edges: 3
Helix angle: 42°
Special features: Face geometry with integrated drill tip

Application:

Perfect for inclined plunging up to 45°, in helix milling and grooving.

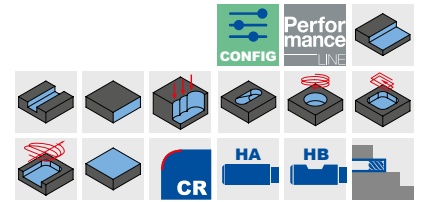

Preferred series in stock

Dimensions							z	Specification	Order no.
d ₁ f8	d ₂ h6	d ₃	l ₁	l ₂	l ₃	R			
5,00	6	4,8	57	13	-	0,2	3	SCM850-0500Z03R-R0020HB-HP913	31054950
6,00	6	5,8	57	13	19	0,2	3	SCM850-0600Z03R-R0020HB-HP913	31054952
8,00	8	7,8	63	19	25	0,2	3	SCM850-0800Z03R-R0020HB-HP913	31054956
10,00	10	9,8	72	22	30	0,32	3	SCM850-1000Z03R-R0032HB-HP913	31054960
12,00	12	11,8	83	26	36	0,32	3	SCM850-1200Z03R-R0032HB-HP913	31054962
14,00	14	13,8	83	26	36	0,32	3	SCM850-1400Z03R-R0032HB-HP913	31054964
16,00	16	15,8	92	31	42	0,32	3	SCM850-1600Z03R-R0032HB-HP913	31054966
20,00	20	19,8	104	41	52	0,5	3	SCM850-2000Z03R-R0050HB-HP913	31054970

Undersize cutters available on request.

Configurable features

Shank form:
Shank form: HA

Specification:
SCM850-0500Z03R-R0020[shank form]-HP913

Example:

SCM850-0500Z03R-R0020HA-HP913

Shank form HA

Dimensions in mm.

For cutting data recommendations, see end of chapter.

Special designs and other coatings available upon request.

OptiMill®-Alu-HPC-Pocket

Shoulder milling cutter, 3xD design with neck, includes chip breaker
SCM854

Design:

Diameter of milling cutter: 5.00 - 20.00 mm
Cutting material: HP913
Number of cutting edges: 4
Helix angle: 36°
Special features: Face geometry with integrated drill tip

Application:

Perfect for inclined plunging up to 45°, in helix milling and grooving.

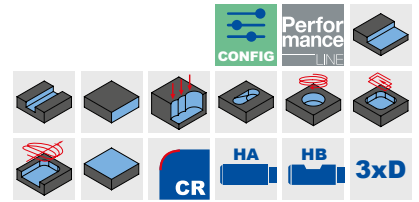
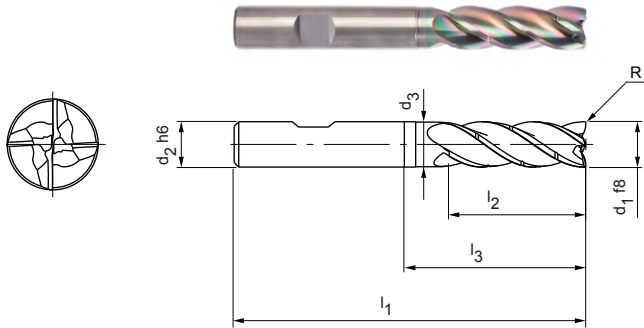

Preferred series in stock

Dimensions							z	Specification	Order no.
d1 f8	d2 h6	d3	l1	l2	l3	R			
5,00	6	4,8	62	17	-	0,20	4	SCM854-0500Z04R-R0020HB-HP913	31302680
6,00	6	5,8	62	18	25	0,20	4	SCM854-0600Z04R-R0020HB-HP913	31302681
8,00	8	7,7	68	24	30	0,20	4	SCM854-0800Z04R-R0020HB-HP913	31302682
10,00	10	9,7	80	30	35	0,32	4	SCM854-1000Z04R-R0032HB-HP913	31302683
12,00	12	11,6	93	36	45	0,32	4	SCM854-1200Z04R-R0032HB-HP913	31302684
14,00	14	13,6	99	42	50	0,32	4	SCM854-1400Z04R-R0032HB-HP913	31302685
16,00	16	15,5	108	48	56	0,32	4	SCM854-1600Z04R-R0032HB-HP913	31302686
20,00	20	19,5	126	60	70	0,50	4	SCM854-2000Z04R-R0050HB-HP913	31302688

Available on request

18,00	18	17,5	117	54	67	0,32	4	SCM854-1800Z04R-R0032HB-HP913	31302687
-------	----	------	-----	----	----	------	---	-------------------------------	----------

Configurable features

Shank form:
Shank form: HA

Specification:
SCM854-0500Z04R-R0020[shank form]-HP913

Example:

SCM854-0500Z04R-R0020**HA**-HP913

Shank form HA

Dimensions in mm.

For cutting data recommendations, see end of chapter.

Special designs and other coatings available upon request.

OptiMill®-Hardened

Shoulder milling cutter, long design with neck
SCM102

Design:

Diameter of milling cutter: 4.00 - 20.00 mm
Cutting material: HP810
Number of cutting edges: 4
Helix angle: 42°

Application:

For roughing of parts with a hardness of 45 HRC.

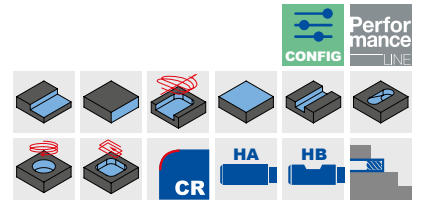
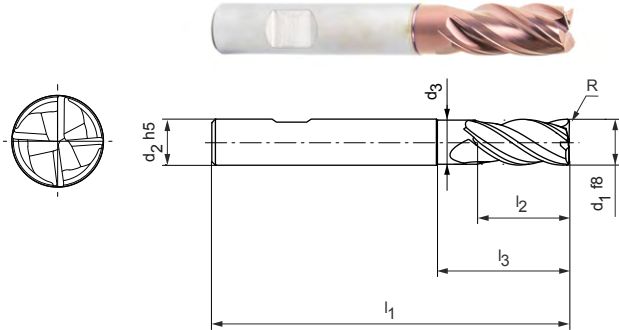

Preferred series in stock

Dimensions							z	Specification	Order no.
d1 f8	d2 h5	d3	l1	l2	l3	R			
4,00	6	-	57	11	-	0,5	4	SCM102-0400Z04R-R0050HB-HP810	31152701
4,00	6	-	57	11	-	1	4	SCM102-0400Z04R-R0100HB-HP810	31152702
6,00	6	5,8	57	13	20	0,5	4	SCM102-0600Z04R-R0050HB-HP810	31152705
6,00	6	5,8	57	13	20	1	4	SCM102-0600Z04R-R0100HB-HP810	31152706
6,00	6	5,8	57	13	20	2	4	SCM102-0600Z04R-R0200HB-HP810	31152708
8,00	8	7,8	63	21	25	0,5	4	SCM102-0800Z04R-R0050HB-HP810	31152709
8,00	8	7,8	63	21	25	1	4	SCM102-0800Z04R-R0100HB-HP810	31152710
8,00	8	7,8	63	21	25	2	4	SCM102-0800Z04R-R0200HB-HP810	31152712
10,00	10	9,8	72	22	30	0,5	4	SCM102-1000Z04R-R0050HB-HP810	31152715
10,00	10	9,8	72	22	30	1	4	SCM102-1000Z04R-R0100HB-HP810	31152716
10,00	10	9,8	72	22	30	2	4	SCM102-1000Z04R-R0200HB-HP810	31152718
12,00	12	11,8	83	26	36	0,5	4	SCM102-1200Z04R-R0050HB-HP810	31152721
12,00	12	11,8	83	26	36	1	4	SCM102-1200Z04R-R0100HB-HP810	31152722
12,00	12	11,8	83	26	36	2	4	SCM102-1200Z04R-R0200HB-HP810	31152724
16,00	16	15,8	92	36	42	0,5	4	SCM102-1600Z04R-R0050HB-HP810	31152728
16,00	16	15,8	92	36	42	1	4	SCM102-1600Z04R-R0100HB-HP810	31152729
16,00	16	15,8	92	36	42	2	4	SCM102-1600Z04R-R0200HB-HP810	31152730
20,00	20	19,8	104	41	55	1	4	SCM102-2000Z04R-R0100HB-HP810	31152734
20,00	20	19,8	104	41	55	2	4	SCM102-2000Z04R-R0200HB-HP810	31152735

Configurable features

Shank form:
Shank form: HA

Specification:
SCM102-0400Z04R-R0050[shank form]-HP810

Example:

SCM102-0400Z04R-R0050HA-HP810

Shank form HA

Dimensions in mm.

For cutting data recommendations, see end of chapter.

Special designs and other coatings available upon request.

OptiMill®-Hardened

Shoulder milling cutter, overlong design with neck
SCM103

Design:

Diameter of milling cutter: 4.00 - 20.00 mm
Cutting material: HP810
Number of cutting edges: 4
Helix angle: 42°

Application:

For roughing of parts with a hardness of 45 HRC.

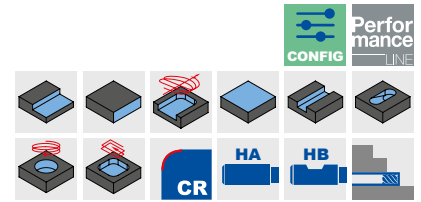
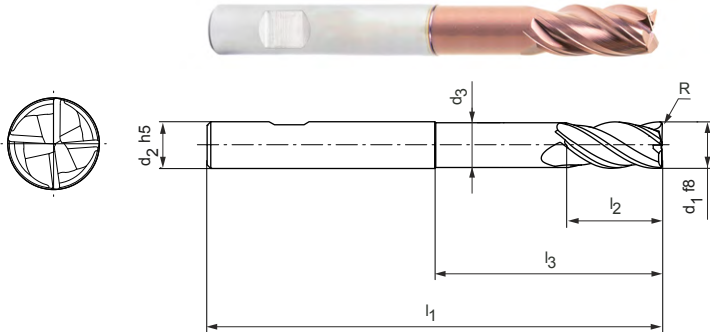

Preferred series in stock

Dimensions							z	Specification	Order no.
d1 f8	d2 h5	d3	l1	l2	l3	R			
4,00	6	3,8	62	11	22	0,5	4	SCM103-0400Z04R-R0050HB-HP810	31152738
4,00	6	3,8	62	11	22	1	4	SCM103-0400Z04R-R0100HB-HP810	31152739
6,00	6	5,8	62	13	25	0,5	4	SCM103-0600Z04R-R0050HB-HP810	31152742
6,00	6	5,8	62	13	25	1	4	SCM103-0600Z04R-R0100HB-HP810	31152743
6,00	6	5,8	62	13	25	2	4	SCM103-0600Z04R-R0200HB-HP810	31152744
8,00	8	7,7	68	21	30	1	4	SCM103-0800Z04R-R0100HB-HP810	31152745
8,00	8	7,7	68	21	30	2	4	SCM103-0800Z04R-R0200HB-HP810	31152746
10,00	10	9,7	80	22	38	0,5	4	SCM103-1000Z04R-R0050HB-HP810	31152747
10,00	10	9,7	80	22	38	1	4	SCM103-1000Z04R-R0100HB-HP810	31152748
10,00	10	9,7	80	22	38	2	4	SCM103-1000Z04R-R0200HB-HP810	31152750
12,00	12	11,6	93	26	46	0,5	4	SCM103-1200Z04R-R0050HB-HP810	31152752
12,00	12	11,6	93	26	46	1	4	SCM103-1200Z04R-R0100HB-HP810	31152753
12,00	12	11,6	93	26	46	2	4	SCM103-1200Z04R-R0200HB-HP810	31152755
16,00	16	15,5	108	36	58	0,5	4	SCM103-1600Z04R-R0050HB-HP810	31152757
16,00	16	15,5	108	36	58	1	4	SCM103-1600Z04R-R0100HB-HP810	31152758
16,00	16	15,5	108	36	58	2	4	SCM103-1600Z04R-R0200HB-HP810	31152759
20,00	20	19,5	126	41	74	1	4	SCM103-2000Z04R-R0100HB-HP810	31152761
20,00	20	19,5	126	41	74	2	4	SCM103-2000Z04R-R0200HB-HP810	31152762

Configurable features

Shank form:
Shank form: HA

Specification:
SCM103-0400Z04R-R0050[shank form]-HP810

Example:

SCM103-0400Z04R-R0050**HA**-HP810

Shank form HA

Dimensions in mm.

For cutting data recommendations, see end of chapter.

Special designs and other coatings available upon request.

OptiMill®-Hardened-Finish

Shoulder milling cutter, 2xD design
SCM104

Design:

Diameter of milling cutter: 4.00 - 25.00 mm
Cutting material: HP808
Number of cutting edges: 6
Helix angle: 55°

Application:

For finishing of parts with a hardness of 45 HRC.

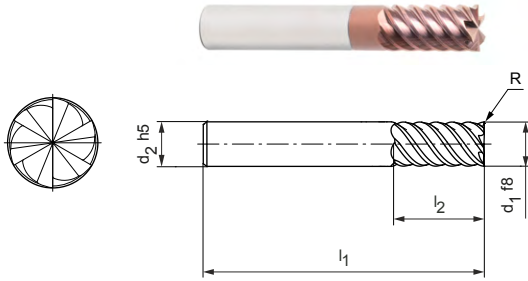

Product configuration bar: P 1 2 3 4 5 6 M 1 2 3 K 1 2 3 N 1 2 3 4 S 1 2 3 4 5 H 1 2 3

Feature icons: CONFIG, Performance LINE, CR, 90°, HA, HB, 2xD

Design with sharp edge | Preferred series in stock

Dimensions					z	Specification	Order no.
d ₁ f8	d ₂ h5	l ₁	l ₂	R			
4,00	6	57	11	-	6	SCM104-0400Z06R-S-HA2-HP808	31152764
5,00	6	57	13	-	6	SCM104-0500Z06R-S-HA2-HP808	31152765
6,00	6	57	13	-	6	SCM104-0600Z06R-S-HA2-HP808	31152766
8,00	8	63	19	-	6	SCM104-0800Z06R-S-HA2-HP808	31152767
10,00	10	72	22	-	6	SCM104-1000Z06R-S-HA2-HP808	31152768
12,00	12	83	26	-	6	SCM104-1200Z06R-S-HA2-HP808	31152769
16,00	16	92	32	-	6	SCM104-1600Z06R-S-HA2-HP808	31152771

Design with sharp edge | Available on request

20,00	20	104	41	-	6	SCM104-2000Z06R-S-HA2-HP808	31152773
25,00	25	125	50	-	6	SCM104-2500Z06R-S-HA2-HP808	31152774

Design with corner radius | Preferred series in stock

4,00	6	57	11	0,5	6	SCM104-0400Z06R-R0050HA2-HP808	31199098
5,00	6	57	13	0,5	6	SCM104-0500Z06R-R0050HA2-HP808	31199099
5,00	6	57	13	1	6	SCM104-0500Z06R-R0100HA2-HP808	31199100
6,00	6	57	13	0,5	6	SCM104-0600Z06R-R0050HA2-HP808	31199101
6,00	6	57	13	1	6	SCM104-0600Z06R-R0100HA2-HP808	31199102
8,00	8	63	19	0,5	6	SCM104-0800Z06R-R0050HA2-HP808	31199103
8,00	8	63	19	1	6	SCM104-0800Z06R-R0100HA2-HP808	31199104
10,00	10	72	22	0,5	6	SCM104-1000Z06R-R0050HA2-HP808	31199105
10,00	10	72	22	1	6	SCM104-1000Z06R-R0100HA2-HP808	31199106
12,00	12	83	26	0,5	6	SCM104-1200Z06R-R0050HA2-HP808	31199107
12,00	12	83	26	1	6	SCM104-1200Z06R-R0100HA2-HP808	31199108
16,00	16	92	32	0,5	6	SCM104-1600Z06R-R0050HA2-HP808	31199109
16,00	16	92	32	1	6	SCM104-1600Z06R-R0100HA2-HP808	31199110
16,00	16	92	32	2	6	SCM104-1600Z06R-R0200HA2-HP808	31199111

Design with corner radius | Available on request

20,00	20	104	41	1	6	SCM104-2000Z06R-R0100HA2-HP808	31199112
20,00	20	104	41	2	6	SCM104-2000Z06R-R0200HA2-HP808	31199113

Configurable features



Shank form:
Shank form: HB

**Specification:**

SCM104-0400Z06R-S-[shank form]2-HP808

Example:

SCM104-0400Z06R-S-**HB**4-HP808

Shank form HB

Dimensions in mm.

For cutting data recommendations, see end of chapter.

Special designs and other coatings available upon request.

OptiMill®-Hardened-Finish

Shoulder milling cutter, 3xD design
SCM104

Design:

Diameter of milling cutter: 4.00 - 25.00 mm
Cutting material: HP808
Number of cutting edges: 6
Helix angle: 55°

Application:

For finishing of parts with a hardness of 45 HRC.

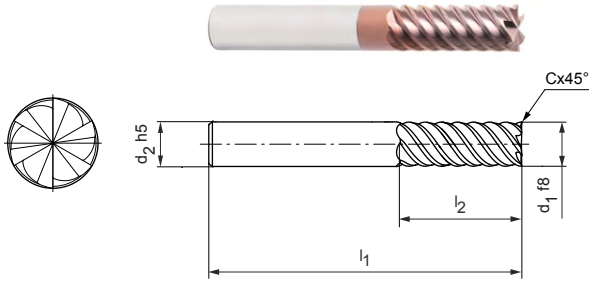

Product configuration bar: P 1 2 3 4 5 6 M 1 2 3 K 1 2 3 N 1 2 3 4 S 1 2 3 4 5 H 1 2 3

Icons: CONFIG, Performance LINE, CR, 90°, HA, HB, 3xD

Design with sharp edge | Preferred series in stock

Dimensions					z	Specification	Order no.
d ₁ f8	d ₂ h5	l ₁	l ₂	R			
4,00	6	62	16	-	6	SCM104-0400Z06R-S-HA3-HP808	31152775
5,00	6	62	17	-	6	SCM104-0500Z06R-S-HA3-HP808	31152776
6,00	6	62	18	-	6	SCM104-0600Z06R-S-HA3-HP808	31152777
8,00	8	68	24	-	6	SCM104-0800Z06R-S-HA3-HP808	31152778
10,00	10	80	30	-	6	SCM104-1000Z06R-S-HA3-HP808	31152779
12,00	12	93	36	-	6	SCM104-1200Z06R-S-HA3-HP808	31152780
16,00	16	108	48	-	6	SCM104-1600Z06R-S-HA3-HP808	31152782

Design with sharp edge | Available on request

20,00	20	126	60	-	6	SCM104-2000Z06R-S-HA3-HP808	31152785
25,00	25	150	75	-	6	SCM104-2500Z06R-S-HA3-HP808	31152786

Design with corner radius | Preferred series in stock

4,00	6	62	16	0,5	6	SCM104-0400Z06R-R0050HA3-HP808	31199114
5,00	6	62	17	0,5	6	SCM104-0500Z06R-R0050HA3-HP808	31199115
5,00	6	62	17	1	6	SCM104-0500Z06R-R0100HA3-HP808	31199116
6,00	6	62	18	0,5	6	SCM104-0600Z06R-R0050HA3-HP808	31199117
6,00	6	62	18	1	6	SCM104-0600Z06R-R0100HA3-HP808	31199118
8,00	8	68	24	0,5	6	SCM104-0800Z06R-R0050HA3-HP808	31199119
8,00	8	68	24	1	6	SCM104-0800Z06R-R0100HA3-HP808	31199120
10,00	10	80	30	0,5	6	SCM104-1000Z06R-R0050HA3-HP808	31199121
10,00	10	80	30	1	6	SCM104-1000Z06R-R0100HA3-HP808	31199122
12,00	12	93	36	0,5	6	SCM104-1200Z06R-R0050HA3-HP808	31199123
12,00	12	93	36	1	6	SCM104-1200Z06R-R0100HA3-HP808	31199124
16,00	16	108	48	0,5	6	SCM104-1600Z06R-R0050HA3-HP808	31199125
16,00	16	108	48	1	6	SCM104-1600Z06R-R0100HA3-HP808	31199126
16,00	16	108	48	2	6	SCM104-1600Z06R-R0200HA3-HP808	31199127

Design with corner radius | Available on request

20,00	20	126	60	1	6	SCM104-2000Z06R-R0100HA2-HP808	31199128
20,00	20	126	60	2	6	SCM104-2000Z06R-R0200HA2-HP808	31199129

Configurable features



Shank form:
Shank form: HB

**Specification:**

SCM104-0400Z06R-S-[shank form]3-HP808

Example:

SCM104-0400Z06R-S-**HB3**-HP808

Shank form HB

Dimensions in mm.

For cutting data recommendations, see end of chapter.

Special designs and other coatings available upon request.

OptiMill®-Hardened-Finish

Shoulder milling cutter, extra long design with neck
SCM124

Design:

Diameter of milling cutter: 6.00 - 20.00 mm
Cutting material: HP808
Number of cutting edges: 6
Helix angle: 55°

Application:

For finishing of parts with a hardness of 45 HRC.

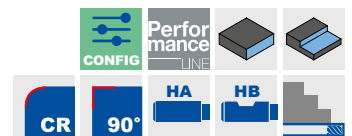
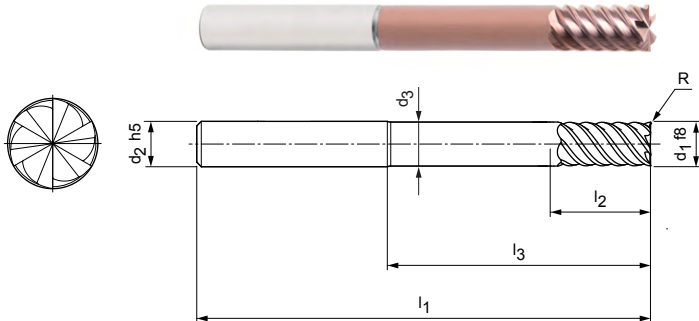

Design with sharp edge | Preferred series in stock

Dimensions							z	Specification	Order no.
d1 f8	d2 h5	d3	l1	l2	l3	R			
6,00	6	5,8	80	13	42	-	6	SCM124-0600Z06R-S-HA-HP808	31199092
8,00	8	7,8	100	21	62	-	6	SCM124-0800Z06R-S-HA-HP808	31199093
10,00	10	9,7	100	22	58	-	6	SCM124-1000Z06R-S-HA-HP808	31199094
12,00	12	11,7	120	26	73	-	6	SCM124-1200Z06R-S-HA-HP808	31199095
16,00	16	15,6	150	36	100	-	6	SCM124-1600Z06R-S-HA-HP808	31199096

Design with sharp edge | Available on request

20,00	20	19,5	150	41	98	-	6	SCM124-2000Z06R-S-HA-HP808	31199097
-------	----	------	-----	----	----	---	---	----------------------------	----------

Design with corner radius | Preferred series in stock

6,00	6	5,8	80	13	42	0,5	6	SCM124-0600Z06R-R0050HA-HP808	31199130
6,00	6	5,8	80	13	42	1	6	SCM124-0600Z06R-R0100HA-HP808	31199131
8,00	8	7,8	100	21	62	0,5	6	SCM124-0800Z06R-R0050HA-HP808	31199132
8,00	8	7,8	100	21	62	1	6	SCM124-0800Z06R-R0100HA-HP808	31199133
10,00	10	9,7	100	22	58	0,5	6	SCM124-1000Z06R-R0050HA-HP808	31199134
10,00	10	9,7	100	22	58	1	6	SCM124-1000Z06R-R0100HA-HP808	31199135
12,00	12	11,7	120	26	73	0,5	6	SCM124-1200Z06R-R0050HA-HP808	31199136
12,00	12	11,7	120	26	73	1	6	SCM124-1200Z06R-R0100HA-HP808	31199137
16,00	16	15,6	150	36	100	0,5	6	SCM124-1600Z06R-R0050HA-HP808	31199138
16,00	16	15,6	150	36	100	1	6	SCM124-1600Z06R-R0100HA-HP808	31199139
16,00	16	15,6	150	36	100	2	6	SCM124-1600Z06R-R0200HA-HP808	31199140

Design with corner radius | Available on request

20,00	20	19,5	150	41	98	1	6	SCM124-2000Z06R-R0100HA-HP808	31199141
20,00	20	19,5	150	41	98	2	6	SCM124-2000Z06R-R0200HA-HP808	31199142

Configurable features



Shank form:
Shank form: HB



Specification:
SCM124-0600Z06R-S-[shank form]-HP808

Example:

SCM124-0600Z06R-S-HB-HP808

Shank form HB

Dimensions in mm.

For cutting data recommendations, see end of chapter.

Special designs and other coatings available upon request.

OptiMill®-Graphite-MT

Shoulder milling cutter, multi-tooth milling cutter, z=2
SCM105

Design:

Diameter of milling cutter: 3.00 - 12.00 mm
Cutting material: HC117
Number of cutting edges: 2
Special features: Diamond coating

Application:

Especially when it comes to roughing for high rates of removal for graphite electrodes.

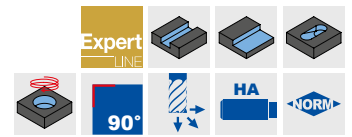
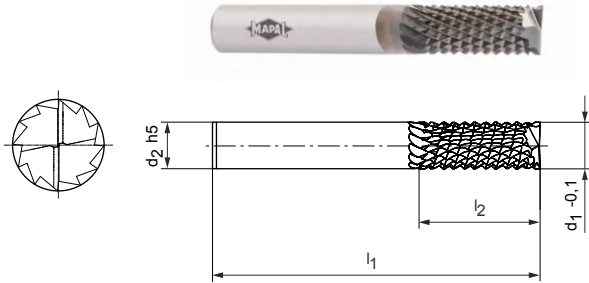

Preferred series in stock

Dimensions				z	Specification	Order no.
d ₁ -0.1	d ₂ h5	l ₁	l ₂			
3,00	3	50	10	2	SCM105-0300ZGVR-HA-HC117	31153048
4,00	4	50	10	2	SCM105-0400ZGVR-HA-HC117	31153049
6,00	6	57	20	2	SCM105-0600ZGVR-HA-HC117	31153050
8,00	8	60	20	2	SCM105-0800ZGVR-HA-HC117	31153051
10,00	10	70	25	2	SCM105-1000ZGVR-HA-HC117	31153052
12,00	12	85	30	2	SCM105-1200ZGVR-HA-HC117	31153053

Dimensions in mm.

For cutting data recommendations, see end of chapter.

Special designs and other coatings available upon request.

OptiMill®-Graphite-MT

Shoulder milling cutter, multi-tooth milling cutter, z=8-16
SCM106

Design:

Diameter of milling cutter: 4.00 - 12.00 mm
Cutting material: HC117
Number of cutting edges: 8-16
Special features: Diamond coating

Application:

Especially when it comes to roughing for high rates of removal for graphite electrodes.

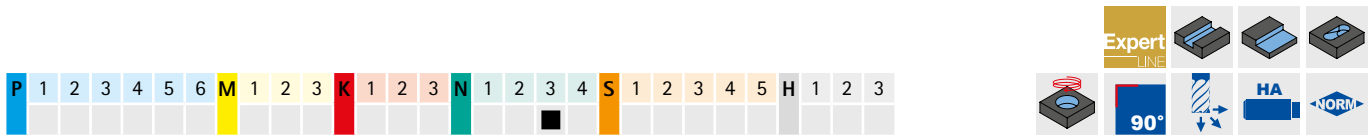
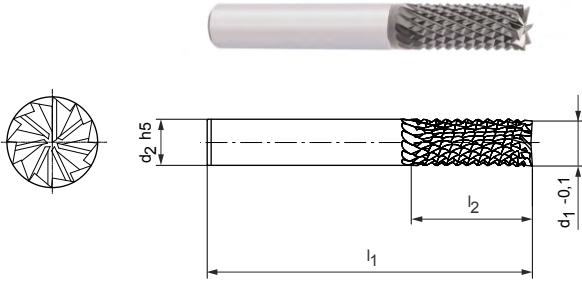

Preferred series in stock

Dimensions				z	Specification	Order no.
d ₁ -0.1	d ₂ h5	l ₁	l ₂			
4,00	4	50	16	8	SCM106-0400ZMVR-HA-HC117	31153054
5,00	6	57	16	8	SCM106-0500ZMVR-HA-HC117	31153055
6,00	6	57	19	10	SCM106-0600ZMVR-HA-HC117	31153056
8,00	8	63	25	12	SCM106-0800ZMVR-HA-HC117	31153057
10,00	10	72	25	14	SCM106-1000ZMVR-HA-HC117	31153058
12,00	12	83	30	16	SCM106-1200ZMVR-HA-HC117	31153059

Dimensions in mm.

For cutting data recommendations, see end of chapter.

Special designs and other coatings available upon request.

OptiMill®-Diamond-Type 51

Shoulder milling cutter, overlong design with neck, includes internal cooling
SHM511 | SHM611 | SHM711

Design:

Diameter of milling cutter: 3.00 - 12.00 mm
Cutting material: PU611
Number of cutting edges: 2
Axis angle: neutral/positive/negative
Special features: PCD cutting edge

Application:

All-rounder tool. Preferred for trimming and pocket milling.

Process alternative: Milling instead of drilling, thanks to a blade above centre.

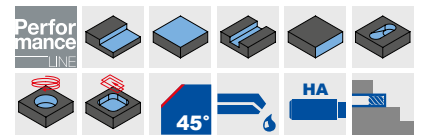
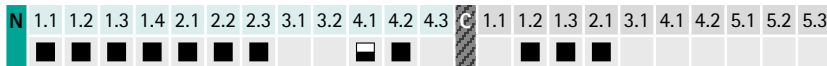
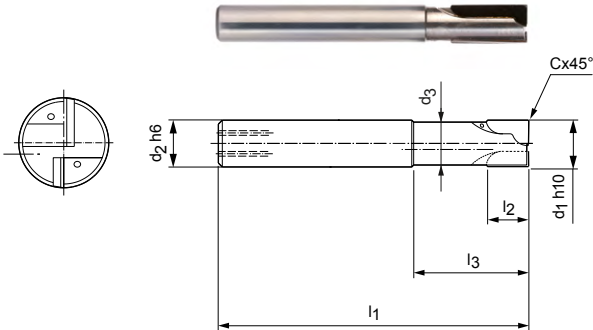

Preferred series in stock

Dimensions							z	Specification	Order no.		
d ₁ h10	d ₂ h6	d ₃	l ₁	l ₂	l ₃	Cx45°			SHM511	SHM611	SHM711
3,00	6	2,8	60	2,5	15	0,10	2	SHM *1-0300AZ02R-F0010HA-PU611	31348188	31348210	31348222
4,00	6	3,8	60	2,5	15	0,10	2	SHM *1-0400AZ02R-F0010HA-PU611	31348189	31348211	31348223
5,00	6	4,6	60	3	15	0,10	2	SHM *1-0500AZ02R-F0010HA-PU611	31348200	31348212	31348224
6,00	6	5,4	60	15	20	0,10	2	SHM *1-0600CZ02R-F0010HA-PU611	31348202	31348214	31348226
8,00	8	7,4	80	20	30	0,10	2	SHM *1-0800DZ02R-F0010HA-PU611	31348204	31348216	31348228
10,00	10	9,4	90	20	30	0,10	2	SHM *1-1000DZ02R-F0010HA-PU611	31348206	31348218	31348230
12,00	12	11	100	20	30	0,10	2	SHM *1-1200DZ02R-F0010HA-PU611	31348208	31348220	31348232
16,00	16	15	125	20	30	0,10	2	SHM *1-1600DZ02R-F0010HA-PU611	31348209	31348221	31348233

Cutting edge form

SHM511	SHM611	SHM711
Neutral axis angle	Negative axis angle	Positive axis angle
<p>Straight cutting edge For changing applications where high tool stability is required.</p>	<p>Pushing cutting edge The material is pressed onto the base. Ideal for finishing vibration-prone and unstable components. Not suitable for roughing or ramping.</p>	<p>Pulling cutting edge Soft cut and low process forces. Recommended for universal applications.</p>

Dimensions in mm.

* Specification as well as desired cutting edge form (see cutting edge form table).

For cutting data recommendations, see end of chapter.

Special designs and CVD-tipped tools available upon request.

Cutting data recommendations for shoulder milling cutters

Feed and cutting speed

Groove milling

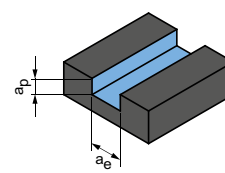

$$a_p = 1xD$$

$$a_e = 1xD$$

OptiMill-Uni-HPC-Plus | SCM720, 740, 760, 770

MMG*	Workpiece material	Strength/ hardness [N/mm ²] [HRC]	Cooling			v _c [m/min]	f _z [mm]								
			MQL/Air	Dry	KSS		Diameter of milling cutter [mm]								
							2.00	4.00	6.00	8.00	10.00	12.00	16.00	20.00	
P	P1.1	Structural, machining, case hardened and tempering steels, unalloyed	< 700	✓	✓	✓	175	0.013	0.024	0.035	0.044	0.053	0.061	0.075	0.085
	P1.2	Structural, machining, case hardened and tempering steels, unalloyed	< 1,200	✓	✓	✓	145	0.012	0.023	0.032	0.041	0.050	0.057	0.070	0.080
	P2.1	Nitriding, hardening and tempering steels, alloyed	< 900	✓	✓	✓	160	0.013	0.024	0.035	0.044	0.053	0.061	0.075	0.085
	P2.2	Nitriding, hardening and tempering steels, alloyed	< 1,400	✓	✓	✓	110	0.011	0.020	0.029	0.037	0.044	0.051	0.062	0.071
	P3.1	Tool, bearing, spring and high-speed steels**	< 800	✓	✓	✓	105	0.012	0.023	0.034	0.043	0.051	0.059	0.072	0.082
	P3.2	Tool, bearing, spring and high-speed steels**	< 1,000	✓	✓	✓	95	0.012	0.022	0.032	0.041	0.049	0.056	0.068	0.078
	P3.3	Tool, bearing, spring and high-speed steels**	< 1,500	✓	✓	✓	85	0.011	0.021	0.030	0.038	0.046	0.053	0.065	0.074
	P4.1	Stainless steels, ferritic and martensitic		✓	✓	✓	70	0.008	0.016	0.023	0.030	0.035	0.041	0.050	0.057
	P5.1	Cast steel		✓	✓	✓	105	0.012	0.023	0.034	0.043	0.051	0.059	0.072	0.082
P6.1	Stainless cast steels, ferritic and martensitic		✓	✓	✓	70	0.006	0.011	0.016	0.021	0.025	0.028	0.035	0.040	
M	M1.1	Stainless steels, austenitic	< 700	✓	✓	✓	50	0.007	0.014	0.020	0.026	0.031	0.036	0.043	0.050
	M1.2	Stainless steels, ferritic/austenitic (duplex)	< 1,000	✓	✓	✓	45	0.006	0.012	0.017	0.021	0.026	0.029	0.036	0.041
	M2.1	Stainless cast steel, austenitic	< 700	✓	✓	✓	50	0.008	0.015	0.022	0.028	0.034	0.039	0.047	0.054
	M3.1	Stainless cast steel, ferritic/austenitic (duplex)	< 1,000	✓	✓	✓	50	0.006	0.012	0.017	0.022	0.027	0.031	0.037	0.043
K	K1.1	Cast iron with lamellar graphite (grey cast iron), GJL	< 300	✓	✓	✓	190	0.021	0.040	0.058	0.074	0.088	0.102	0.124	0.142
	K2.1	Cast iron with spheroidal graphite, GJS	< 500	✓	✓	✓	175	0.018	0.034	0.049	0.063	0.075	0.086	0.106	0.121
	K2.2	Cast iron with spheroidal graphite, GJS	≤ 800	✓	✓	✓	145	0.015	0.028	0.040	0.052	0.062	0.071	0.087	0.099
	K2.3	Cast iron with spheroidal graphite, GJS	> 800	✓	✓	✓	80	0.008	0.016	0.023	0.030	0.035	0.041	0.050	0.057
	K3.1	Cast iron with vermicular graphite, GJV; malleable cast iron, GJM	< 500	✓	✓	✓	125	0.015	0.028	0.040	0.052	0.062	0.071	0.087	0.099
	K3.2	Cast iron with vermicular graphite, GJV; malleable cast iron, GJM	> 500	✓	✓	✓	120	0.013	0.024	0.035	0.044	0.053	0.061	0.075	0.085

Tool length correction factor – k_{WL}

Length	Correction factors	
	f _z	v _c
short	1	1
long	0.9	0.9
Overlong	0.8	0.8
Extra long	0.6	0.6

Note:

To determine cutting data, please observe the notes on page 548-551.

* MAPAL machining groups

** If the alloy parts Cr, Mo, Ni, V, W in total > 8%, then select the next highest MAPAL machining group.

Roughing

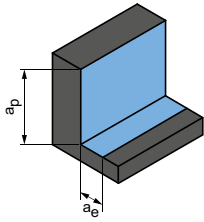

$$a_p = 1.5xD$$

$$a_e = 0.25xD$$

Finishing

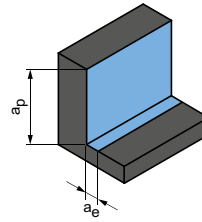

$$a_p = 1.5xD$$

$$a_e = 0.1xD$$

	v_c [m/min]	f_z [mm]								v_c [m/min]	f_z [mm]							
		Diameter of milling cutter [mm]									Diameter of milling cutter [mm]							
		2.00	4.00	6.00	8.00	10.00	12.00	16.00	20.00		2.00	4.00	6.00	8.00	10.00	12.00	16.00	20.00
	355	0.021	0.041	0.059	0.075	0.090	0.103	0.126	0.145	525	0.034	0.065	0.093	0.119	0.142	0.164	0.200	0.228
	290	0.020	0.038	0.055	0.070	0.084	0.097	0.118	0.135	430	0.032	0.060	0.087	0.111	0.133	0.153	0.187	0.213
	325	0.021	0.041	0.059	0.075	0.090	0.103	0.126	0.145	475	0.034	0.065	0.093	0.119	0.142	0.164	0.200	0.228
	225	0.018	0.034	0.049	0.063	0.075	0.086	0.105	0.120	335	0.028	0.054	0.078	0.099	0.119	0.136	0.167	0.190
	210	0.021	0.040	0.057	0.073	0.087	0.100	0.122	0.140	310	0.033	0.063	0.090	0.115	0.138	0.158	0.193	0.221
	195	0.020	0.038	0.054	0.069	0.083	0.095	0.116	0.132	285	0.031	0.059	0.085	0.109	0.130	0.150	0.183	0.209
	180	0.019	0.035	0.051	0.065	0.078	0.090	0.110	0.125	260	0.029	0.056	0.081	0.103	0.123	0.142	0.173	0.198
	145	0.014	0.027	0.039	0.050	0.060	0.069	0.084	0.096	215	0.023	0.043	0.062	0.079	0.095	0.109	0.133	0.152
	215	0.021	0.040	0.057	0.073	0.087	0.100	0.122	0.140	320	0.033	0.063	0.090	0.115	0.138	0.158	0.193	0.221
	145	0.010	0.019	0.027	0.035	0.042	0.048	0.059	0.067	215	0.016	0.030	0.043	0.055	0.066	0.076	0.093	0.107
	95	0.012	0.024	0.034	0.044	0.053	0.060	0.074	0.084	145	0.020	0.038	0.054	0.069	0.083	0.095	0.117	0.133
	90	0.010	0.020	0.028	0.036	0.044	0.050	0.061	0.070	135	0.016	0.031	0.045	0.057	0.069	0.079	0.097	0.110
	105	0.014	0.026	0.037	0.048	0.057	0.066	0.080	0.092	155	0.021	0.041	0.059	0.075	0.090	0.104	0.127	0.145
	95	0.011	0.020	0.029	0.038	0.045	0.052	0.063	0.072	145	0.017	0.032	0.047	0.059	0.071	0.082	0.100	0.114
	390	0.036	0.068	0.098	0.125	0.150	0.172	0.211	0.241	570	0.056	0.108	0.155	0.198	0.237	0.273	0.333	0.381
	355	0.030	0.058	0.083	0.106	0.128	0.147	0.179	0.205	525	0.048	0.092	0.132	0.168	0.202	0.232	0.283	0.324
	290	0.025	0.048	0.069	0.088	0.105	0.121	0.147	0.169	430	0.040	0.076	0.109	0.139	0.166	0.191	0.233	0.267
	160	0.014	0.027	0.039	0.050	0.060	0.069	0.084	0.096	240	0.023	0.043	0.062	0.079	0.095	0.109	0.133	0.152
	260	0.025	0.048	0.069	0.088	0.105	0.121	0.147	0.169	380	0.040	0.076	0.109	0.139	0.166	0.191	0.233	0.267
	245	0.021	0.041	0.059	0.075	0.090	0.103	0.126	0.145	355	0.034	0.065	0.093	0.119	0.142	0.164	0.200	0.228

The specified machining values are guide values.
The optimum data for the respective machining task should be determined during the test or machining.

Cutting data recommendations for shoulder milling cutters

Feed and cutting speed

OptiMill-Uni-HPC-Finish | SCM830

MMG*	Workpiece material	Strength/hardness [N/mm ²] [HRC]	Cooling			
			MQL/Air	Dry	Wet	
P	P1.1	Structural, machining, case hardened and tempering steels, unalloyed	< 700	✓	✓	✓
	P1.2	Structural, machining, case hardened and tempering steels, unalloyed	< 1,200	✓	✓	✓
	P2.1	Nitriding, hardening and tempering steels, alloyed	< 900	✓	✓	✓
	P2.2	Nitriding, hardening and tempering steels, alloyed	< 1,400	✓		✓
	P3.1	Tool, bearing, spring and high-speed steels**	< 800	✓	✓	✓
	P3.2	Tool, bearing, spring and high-speed steels**	< 1,000	✓		✓
	P3.3	Tool, bearing, spring and high-speed steels**	< 1,500	✓		✓
	P4.1	Stainless steels, ferritic and martensitic		✓		✓
	P5.1	Cast steel				✓
	P6.1	Stainless cast steels, ferritic and martensitic				✓
M	M1.1	Stainless steels, austenitic	< 700	✓		✓
	M1.2	Stainless steels, ferritic/austenitic (duplex)	< 1,000			✓
	M2.1	Stainless cast steel, austenitic	< 700	✓		✓
	M3.1	Stainless cast steel, ferritic/austenitic (duplex)	< 1,000			✓
K	K1.1	Cast iron with lamellar graphite (grey cast iron), GJL	< 300	✓	✓	✓
	K2.1	Cast iron with spheroidal graphite, GJS	< 500	✓	✓	✓
	K2.2	Cast iron with spheroidal graphite, GJS	≤ 800	✓	✓	✓
	K2.3	Cast iron with spheroidal graphite, GJS	> 800	✓	✓	✓
	K3.1	Cast iron with vermicular graphite, GJV; malleable cast iron, GJM	< 500	✓	✓	✓
	K3.2	Cast iron with vermicular graphite, GJV; malleable cast iron, GJM	> 500	✓	✓	✓
S	S1.1	Titanium, titanium alloys	< 400			✓
	S2.1	Titanium, titanium alloys	< 1,200			✓
	S2.2	Titanium, titanium alloys	> 1,200			✓

Tool length correction factor – k_{WL} 3xD/4xD/5xD ***

Max. machining depth a_p	a_e max.	Correction factors	
		v_c	f_z
3xD	0,05xD	0,9	0,9
4xD	0,03xD	0,9	0,7
5xD	0,03xD	0,8	0,6

Note:

To determine cutting data, please observe the notes on page 548-551.

* MAPAL machining groups

** If the alloy parts Cr, Mo, Ni, V, W in total > 8%, then select the next highest MAPAL machining group.

*** In order to achieve very good surface results, the feed rate must be reduced further!

Finishing

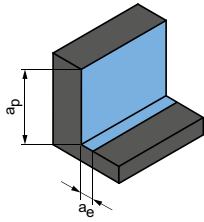

$$a_p = 1.5 \times D$$

$$a_e = 0.1 \times D$$

v_c [m/min]	f_z [mm]								
	Diameter of milling cutter [mm]								
	4.00	6.00	8.00	10.00	12.00	16.00	20.00	25.00	
385	0.042	0.06	0.077	0.093	0.106	0.13	0.149	0.166	
315	0.039	0.056	0.072	0.086	0.099	0.121	0.139	0.155	
350	0.042	0.06	0.077	0.093	0.106	0.13	0.149	0.166	
245	0.035	0.05	0.064	0.077	0.089	0.108	0.124	0.138	
225	0.041	0.058	0.075	0.089	0.103	0.126	0.144	0.16	
210	0.039	0.055	0.071	0.085	0.097	0.119	0.136	0.152	
190	0.036	0.052	0.067	0.08	0.092	0.113	0.129	0.144	
155	0.028	0.04	0.052	0.062	0.071	0.087	0.099	0.11	
235	0.041	0.058	0.075	0.089	0.103	0.126	0.144	0.16	
155	0.02	0.028	0.036	0.043	0.05	0.061	0.069	0.077	
130	0.025	0.035	0.045	0.054	0.062	0.076	0.087	0.097	
120	0.02	0.029	0.037	0.045	0.051	0.063	0.072	0.08	
145	0.027	0.038	0.049	0.059	0.067	0.082	0.094	0.105	
130	0.021	0.03	0.039	0.046	0.053	0.065	0.074	0.083	
520	0.07	0.101	0.129	0.154	0.177	0.216	0.248	0.276	
475	0.06	0.086	0.109	0.131	0.151	0.184	0.21	0.235	
390	0.049	0.071	0.09	0.108	0.124	0.152	0.173	0.193	
215	0.028	0.04	0.052	0.062	0.071	0.087	0.099	0.11	
345	0.049	0.071	0.09	0.108	0.124	0.152	0.173	0.193	
325	0.042	0.06	0.077	0.093	0.106	0.13	0.149	0.166	
135	0.021	0.030	0.038	0.046	0.052	0.064	0.073	0.082	
120	0.017	0.024	0.031	0.037	0.043	0.052	0.060	0.067	
80	0.015	0.022	0.028	0.033	0.038	0.047	0.053	0.059	

The specified machining values are guide values.
The optimum data for the respective machining task should be determined during the test or machining.

Cutting data recommendations for shoulder milling cutters

Feed and cutting speed

Groove milling

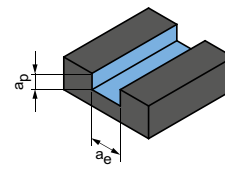

$$a_p = 1xD$$

$$a_e = 1xD$$

OptiMill-Uni-Wave | SCM800, 880, 890, 900, 910

MMG*	Workpiece material	Strength/hardness [N/mm ²] [HRC]	Cooling			v _c [m/min]	f _z [mm]									
			MQL/Air	Dry	KSS		Diameter of milling cutter [mm]									
							4.00	6.00	8.00	10.00	12.00	16.00	20.00	25.00		
P	P1.1	Structural, machining, case hardened and tempering steels, unalloyed	< 700	✓	✓	✓	200	0.027	0.038	0.049	0.058	0.067	0.082	0.094	0.105	
	P1.2	Structural, machining, case hardened and tempering steels, unalloyed	< 1,200	✓	✓	✓	160	0.025	0.036	0.046	0.054	0.063	0.077	0.087	0.098	
	P2.1	Nitriding, hardening and tempering steels, alloyed	< 900	✓	✓	✓	180	0.027	0.038	0.049	0.058	0.067	0.082	0.094	0.105	
	P2.2	Nitriding, hardening and tempering steels, alloyed	< 1,400	✓	✓	✓	125	0.022	0.032	0.041	0.049	0.056	0.068	0.078	0.087	
	P3.1	Tool, bearing, spring and high-speed steels**	< 800	✓	✓	✓	115	0.026	0.037	0.047	0.056	0.065	0.079	0.091	0.101	
	P3.2	Tool, bearing, spring and high-speed steels**	< 1,000	✓	✓	✓	110	0.024	0.035	0.045	0.054	0.062	0.075	0.086	0.096	
	P3.3	Tool, bearing, spring and high-speed steels**	< 1,500	✓	✓	✓	100	0.023	0.033	0.042	0.051	0.058	0.071	0.081	0.091	
	P4	P4.1	Stainless steels, ferritic and martensitic		✓	✓	80	0.018	0.025	0.033	0.039	0.045	0.055	0.062	0.07	
P5	P5.1	Cast steel			✓	120	0.026	0.037	0.047	0.056	0.065	0.079	0.091	0.101		
P6	P6.1	Stainless cast steels, ferritic and martensitic			✓	80	0.012	0.018	0.023	0.027	0.031	0.038	0.044	0.049		
M	M1.1	Stainless steels, austenitic	< 700	✓		✓	55	0.015	0.022	0.028	0.034	0.039	0.048	0.055	0.061	
	M1.2	Stainless steels, ferritic/austenitic (duplex)	< 1,000			✓	50	0.013	0.018	0.024	0.028	0.032	0.04	0.045	0.051	
	M2	M2.1	Stainless cast steel, austenitic	< 700	✓		✓	60	0.017	0.024	0.031	0.037	0.042	0.052	0.059	0.066
	M3	M3.1	Stainless cast steel, ferritic/austenitic (duplex)	< 1,000			✓	55	0.013	0.019	0.024	0.029	0.034	0.041	0.047	0.052
K	K1	K1.1	Cast iron with lamellar graphite (grey cast iron), GJL	< 300	✓	✓	✓	215	0.044	0.064	0.081	0.097	0.112	0.137	0.156	0.174
	K1	K2.1	Cast iron with spheroidal graphite, GJS	< 500	✓	✓	✓	200	0.038	0.054	0.069	0.083	0.095	0.116	0.133	0.148
	K2	K2.2	Cast iron with spheroidal graphite, GJS	≤ 800	✓	✓	✓	160	0.031	0.045	0.057	0.068	0.078	0.096	0.109	0.122
	K2	K2.3	Cast iron with spheroidal graphite, GJS	> 800	✓	✓	✓	90	0.018	0.025	0.033	0.039	0.045	0.055	0.062	0.07
	K3	K3.1	Cast iron with vermicular graphite, GJV; malleable cast iron, GJM	< 500	✓	✓	✓	145	0.031	0.045	0.057	0.068	0.078	0.096	0.109	0.122
	K3	K3.2	Cast iron with vermicular graphite, GJV; malleable cast iron, GJM	> 500	✓	✓	✓	135	0.027	0.038	0.049	0.058	0.067	0.082	0.094	0.105

Tool length correction factor – k_{WL}

Length	Correction factors	
	f _z	v _c
short / long / 3xD	1	1
overlong / 4xD	0.8	0.9
extra long / 5xD	0.6	0.7

Note:

To determine cutting data, please observe the notes on page 548-551.

Please be aware:

Using the SCM900 in the 3xD design is only recommended up to a maximum cutting width of 0.25xD.

* MAPAL machining groups

** If the alloy parts Cr, Mo, Ni, V, W in total > 8%, then select the next highest MAPAL machining group.

Roughing

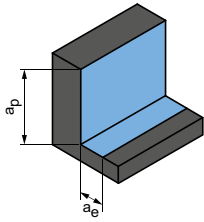

$$a_p = 1.5xD$$

$$a_e = 0.25xD$$

Roughing ***

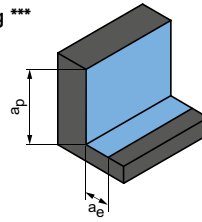

$$a_p = 3xD$$

$$a_e = 0.2xD$$

*** Valid for SCM900 - design 3xD

	v _c [m/min]	f _z [mm]								v _c [m/min]	f _z [mm]							
		Diameter of milling cutter [mm]									Diameter of milling cutter [mm]							
		4.00	6.00	8.00	10.00	12.00	16.00	20.00	25.00		5.00	6.00	8.00	10.00	12.00	16.00	20.00	25.00
	405	0.045	0.065	0.083	0.099	0.114	0.139	0.159	0.177	355	0.054	0.064	0.082	0.098	0.112	0.137	0.157	0.175
	330	0.042	0.06	0.077	0.092	0.106	0.13	0.148	0.166	290	0.051	0.060	0.076	0.091	0.105	0.128	0.146	0.163
	370	0.045	0.065	0.083	0.099	0.114	0.139	0.159	0.177	320	0.054	0.064	0.082	0.098	0.112	0.137	0.157	0.175
	260	0.038	0.054	0.069	0.083	0.095	0.116	0.132	0.148	225	0.045	0.053	0.068	0.081	0.094	0.114	0.131	0.146
	240	0.044	0.063	0.08	0.096	0.11	0.134	0.154	0.171	210	0.053	0.062	0.079	0.094	0.109	0.133	0.152	0.169
	220	0.041	0.059	0.076	0.091	0.104	0.127	0.146	0.163	190	0.050	0.059	0.075	0.090	0.103	0.126	0.144	0.161
	200	0.039	0.056	0.072	0.086	0.099	0.12	0.138	0.154	175	0.047	0.055	0.071	0.085	0.097	0.119	0.136	0.152
	165	0.03	0.043	0.055	0.066	0.076	0.093	0.106	0.118	145	0.036	0.043	0.054	0.065	0.075	0.091	0.105	0.117
	245	0.044	0.063	0.08	0.096	0.11	0.134	0.154	0.171	215	0.053	0.062	0.079	0.094	0.109	0.133	0.152	0.169
	165	0.021	0.03	0.039	0.046	0.053	0.065	0.074	0.083	145	0.025	0.030	0.038	0.046	0.052	0.064	0.073	0.082
	110	0.026	0.038	0.048	0.058	0.066	0.081	0.093	0.103	110	0.032	0.037	0.048	0.057	0.066	0.080	0.092	0.102
	105	0.022	0.031	0.04	0.048	0.055	0.067	0.077	0.086	105	0.026	0.031	0.039	0.047	0.054	0.066	0.076	0.085
	120	0.029	0.041	0.052	0.063	0.072	0.088	0.101	0.112	125	0.034	0.040	0.052	0.062	0.071	0.087	0.099	0.111
	110	0.023	0.032	0.041	0.05	0.057	0.07	0.079	0.089	110	0.027	0.032	0.041	0.049	0.056	0.069	0.078	0.088
	440	0.075	0.108	0.138	0.165	0.19	0.232	0.265	0.296	450	0.091	0.106	0.136	0.163	0.187	0.229	0.262	0.292
	405	0.064	0.092	0.117	0.14	0.161	0.197	0.225	0.251	410	0.077	0.090	0.116	0.138	0.159	0.194	0.222	0.248
	330	0.053	0.076	0.096	0.116	0.133	0.162	0.185	0.207	335	0.063	0.075	0.095	0.114	0.131	0.160	0.183	0.204
	185	0.03	0.043	0.055	0.066	0.076	0.093	0.106	0.118	185	0.036	0.043	0.054	0.065	0.075	0.091	0.105	0.117
	295	0.053	0.076	0.096	0.116	0.133	0.162	0.185	0.207	300	0.063	0.075	0.095	0.114	0.131	0.160	0.183	0.204
	275	0.045	0.065	0.083	0.099	0.114	0.139	0.159	0.177	280	0.054	0.064	0.082	0.098	0.112	0.137	0.157	0.175

The specified machining values are guide values.
The optimum data for the respective machining task should be determined during the test or machining.

Cutting data recommendations for shoulder milling cutters

Feed and cutting speed

Roughing

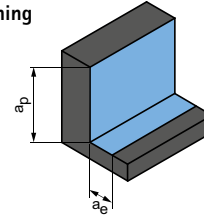

$$a_p = 1.5 \times D$$

$$a_e = 0.25 \times D$$

OptiMill-Uni-HPC-Pocket | SCM800, 810, 840

MMG*	Workpiece material	Strength/hardness [N/mm ²] [HRC]	Cooling			v _c [m/min]	f _z [mm]							
			MQL/Air	Dry	KSS		Diameter of milling cutter [mm]							
							3.80	6.00	8.00	10.00	12.00	16.00	20.00	
P	P1.1	Structural, machining, case hardened and tempering steels, unalloyed	< 700	✓	✓	✓	465	0.053	0.079	0.101	0.122	0.140	0.171	0.195
	P1.2	Structural, machining, case hardened and tempering steels, unalloyed	< 1,200	✓	✓	✓	380	0.049	0.074	0.095	0.113	0.130	0.159	0.182
	P2.1	Nitriding, hardening and tempering steels, alloyed	< 900	✓	✓	✓	425	0.053	0.079	0.101	0.122	0.140	0.171	0.195
	P2.2	Nitriding, hardening and tempering steels, alloyed	< 1,400	✓		✓	295	0.044	0.066	0.085	0.101	0.116	0.142	0.163
	P3.1	Tool, bearing, spring and high-speed steels**	< 800	✓	✓	✓	275	0.051	0.077	0.098	0.117	0.135	0.165	0.189
	P3.2	Tool, bearing, spring and high-speed steels**	< 1,000	✓		✓	255	0.048	0.073	0.093	0.111	0.128	0.156	0.179
	P3.3	Tool, bearing, spring and high-speed steels**	< 1,500	✓		✓	235	0.046	0.069	0.088	0.105	0.121	0.148	0.169
	P4.1	Stainless steels, ferritic and martensitic		✓		✓	190	0.035	0.053	0.068	0.081	0.093	0.114	0.130
	P5.1	Cast steel				✓	285	0.051	0.077	0.098	0.117	0.135	0.165	0.189
P6.1	Stainless cast steels, ferritic and martensitic				✓	190	0.025	0.037	0.047	0.057	0.065	0.080	0.091	
M	M1.1	Stainless steels, austenitic	< 700	✓		✓	125	0.031	0.046	0.059	0.071	0.081	0.100	0.114
	M1.2	Stainless steels, ferritic/austenitic (duplex)	< 1,000			✓	120	0.025	0.038	0.049	0.059	0.068	0.082	0.094
	M2.1	Stainless cast steel, austenitic	< 700	✓		✓	140	0.033	0.050	0.064	0.077	0.088	0.108	0.124
	M3.1	Stainless cast steel, ferritic/austenitic (duplex)	< 1,000			✓	125	0.026	0.040	0.051	0.061	0.070	0.085	0.098
K	K1.1	Cast iron with lamellar graphite (grey cast iron), GJL	< 300	✓	✓	✓	510	0.088	0.132	0.169	0.203	0.233	0.284	0.325
	K2.1	Cast iron with spheroidal graphite, GJS	< 500	✓	✓	✓	465	0.075	0.113	0.144	0.172	0.198	0.242	0.276
	K2.2	Cast iron with spheroidal graphite, GJS	≤ 800	✓	✓	✓	380	0.062	0.093	0.118	0.142	0.163	0.199	0.228
	K2.3	Cast iron with spheroidal graphite, GJS	> 800	✓	✓	✓	210	0.035	0.053	0.068	0.081	0.093	0.114	0.130
	K3.1	Cast iron with vermicular graphite, GJV; malleable cast iron, GJM	< 500	✓	✓	✓	340	0.062	0.093	0.118	0.142	0.163	0.199	0.228
	K3.2	Cast iron with vermicular graphite, GJV; malleable cast iron, GJM	> 500	✓	✓	✓	315	0.053	0.079	0.101	0.122	0.140	0.171	0.195

Tool length correction factor – k_{WL}

Length	Correction factors	
	f _z	v _c
short / long	1	1
Overlong	0.8	0.8
Extra long	–	–

Note:

To determine cutting data, please observe the notes on page 548-551.

* MAPAL machining groups

** If the alloy parts Cr, Mo, Ni, V, W in total > 8%, then select the next highest MAPAL machining group.

Groove milling

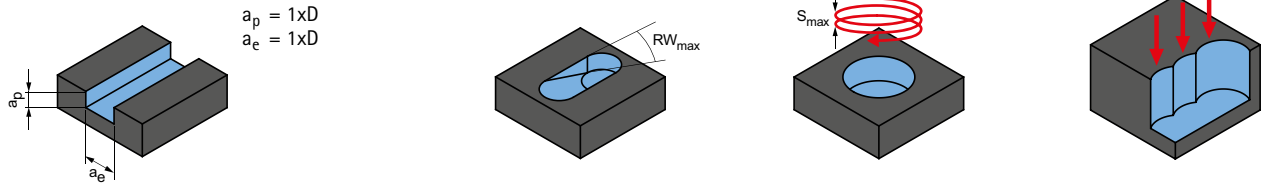

$$a_p = 1 \times D$$

$$a_e = 1 \times D$$

v_c [m/min]	f_z [mm]								Ramps	Helix milling		Drilling	
	Diameter of milling cutter [mm]								RW_{max}	S_{max}	EW_{max}		f_z factor
	3.80	6.00	8.00	10.00	12.00	16.00	20.00	G = 1.5			G = 1.8		
230	0.031	0.047	0.060	0.072	0.082	0.101	0.115	45°	0.75xD	25°	16°	0.9	
185	0.029	0.044	0.056	0.067	0.077	0.094	0.107	45°	0.75xD	25°	16°	0.8	
205	0.031	0.047	0.060	0.072	0.082	0.101	0.115	45°	0.75xD	25°	16°	0.8	
145	0.026	0.039	0.050	0.060	0.069	0.084	0.096	45°	0.75xD	25°	16°	0.7	
135	0.030	0.045	0.058	0.069	0.080	0.097	0.111	30°	0.5xD	18°	11°	0.8	
125	0.029	0.043	0.055	0.066	0.075	0.092	0.105	30°	0.5xD	18°	11°	0.7	
115	0.027	0.041	0.052	0.062	0.071	0.087	0.100	30°	0.5xD	18°	11°	0.7	
95	0.021	0.031	0.040	0.048	0.055	0.067	0.077	15°	0.5xD	18°	11°		
140	0.030	0.045	0.058	0.069	0.080	0.097	0.111	30°	0.5xD	18°	11°		
95	0.015	0.022	0.028	0.033	0.038	0.047	0.054	15°	0.5xD	18°	11°		
60	0.018	0.027	0.035	0.042	0.048	0.059	0.067	15°	0.5xD	18°	11°		
60	0.015	0.023	0.029	0.035	0.040	0.049	0.056	15°	0.5xD	18°	11°		
70	0.020	0.030	0.038	0.045	0.052	0.064	0.073	15°	0.5xD	18°	11°		
60	0.016	0.023	0.030	0.036	0.041	0.050	0.058	15°	0.5xD	18°	11°		
250	0.052	0.078	0.100	0.119	0.137	0.168	0.192	45°	0.75xD	25°	16°	0.8	
230	0.044	0.066	0.085	0.102	0.117	0.143	0.163	45°	0.75xD	25°	16°	0.8	
185	0.036	0.055	0.070	0.084	0.096	0.117	0.134	45°	0.75xD	25°	16°	0.8	
105	0.021	0.031	0.040	0.048	0.055	0.067	0.077	45°	0.75xD	25°	16°	0.8	
165	0.036	0.055	0.070	0.084	0.096	0.117	0.134	45°	0.75xD	25°	16°	0.8	
155	0.031	0.047	0.060	0.072	0.082	0.101	0.115	45°	0.75xD	25°	16°	0.8	

The specified machining values are guide values.
The optimum data for the respective machining task should be determined during the test or machining.

Cutting data recommendations for shoulder milling cutters

Feed and cutting speed

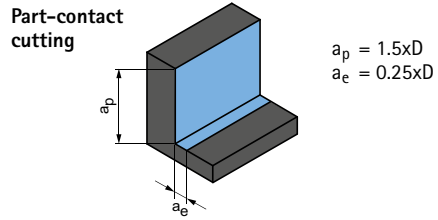

OptiMill-Alu-HPC-Pocket | SCM850

MMG*	Workpiece material	Strength/hardness [N/mm ²] [HRC]	Cooling			v _c [m/min]	f _z [mm]								
			MQL/Air	Dry	KSS		Diameter of milling cutter [mm]								
							5.00	8.00	10.00	12.00	16.00	20.00			
N	N1	N1.1 Aluminium, unalloyed and alloyed < 3% Si	✓	✓	✓	945	0.080	0.120	0.145	0.169	0.210	0.243			
		N1.2 Aluminium, alloyed ≤ 7% Si	✓	✓	✓	625	0.084	0.126	0.152	0.177	0.221	0.256			
		N1.3 Aluminium, alloyed > 7 - 12% Si	✓	✓	✓	500	0.088	0.132	0.160	0.186	0.231	0.268			
		N1.4 Aluminium, alloyed > 12% Si	✓	✓	✓	360	0.096	0.144	0.174	0.202	0.252	0.292			
	N2	N2.1 Copper, unalloyed and low alloyed	< 300	✓	✓	✓	360	0.064	0.096	0.116	0.135	0.168	0.195		
		N2.2 Copper, alloyed	> 300	✓	✓	✓	270	0.064	0.096	0.116	0.135	0.168	0.195		
		N2.3 Brass, bronze, gunmetal	< 1,200	✓	✓	✓	450	0.040	0.060	0.073	0.084	0.105	0.122		
	N4	N4.1 Plastic, thermoplastics		✓	✓	✓	125	0.040	0.060	0.073	0.084	0.105	0.122		
		N4.2 Plastic, duroplastics		✓	✓	✓	185	0.040	0.060	0.073	0.084	0.105	0.122		
		N4.3 Plastic, foam materials		✓	✓	✓	565	0.024	0.036	0.044	0.051	0.063	0.073		

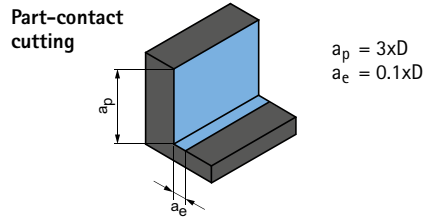

OptiMill-Alu-HPC-Pocket | SCM854

MMG*	Workpiece material	Strength/hardness [N/mm ²] [HRC]	Cooling			v _c [m/min]	f _z [mm]								
			MQL/Air	Dry	KSS		Diameter of milling cutter [mm]								
							5.00	8.00	10.00	12.00	14.00	16.00	18.00	20.00	
N	N1	N1.1 Aluminium, unalloyed and alloyed < 3% Si	✓	✓	✓	915	0.061	0.091	0.110	0.126	0.141	0.154	0.166	0.176	
		N1.2 Aluminium, alloyed ≤ 7% Si	✓	✓	✓	610	0.064	0.096	0.115	0.132	0.148	0.162	0.174	0.185	
		N1.3 Aluminium, alloyed > 7 - 12% Si	✓	✓	✓	485	0.067	0.101	0.121	0.139	0.155	0.169	0.182	0.193	
		N1.4 Aluminium, alloyed > 12% Si	✓	✓	✓	350	0.073	0.110	0.131	0.151	0.169	0.185	0.199	0.211	
	N2	N2.1 Copper, unalloyed and low alloyed	< 300	✓	✓	✓	350	0.049	0.073	0.088	0.101	0.113	0.123	0.132	0.141
		N2.2 Copper, alloyed	> 300	✓	✓	✓	265	0.049	0.073	0.088	0.101	0.113	0.123	0.132	0.141
		N2.3 Brass, bronze, gunmetal	< 1,200	✓	✓	✓	440	0.030	0.046	0.055	0.063	0.070	0.077	0.083	0.088
	N4	N4.1 Plastic, thermoplastics		✓	✓	✓	120	0.030	0.046	0.055	0.063	0.070	0.077	0.083	0.088
		N4.2 Plastic, duroplastics		✓	✓	✓	180	0.030	0.046	0.055	0.063	0.070	0.077	0.083	0.088
		N4.3 Plastic, foam materials		✓	✓	✓	315	0.018	0.027	0.033	0.038	0.042	0.046	0.050	0.053

Example calculation for AISi1 ø 12 mm:

$$f_z | a_e | h_m \text{ max.} = \frac{D}{100} \cdot \text{See table for value}$$

N1.1	Aluminium, unalloyed and alloyed < 3% Si	✓	✓	✓	915	0.061	0.091	0.110	0.126	0.141	0.154	0.166	0.176
------	--	---	---	---	-----	-------	-------	-------	-------	-------	-------	-------	-------

1 $f_z = \frac{12 \text{ mm}}{100} \cdot 1,2 = 0,144 \text{ mm}$

2 $h_m \text{ max.} = \frac{12 \text{ mm}}{100} \cdot 0,84 = 0,101 \text{ mm}$

* MAPAL machining groups

Full cutting

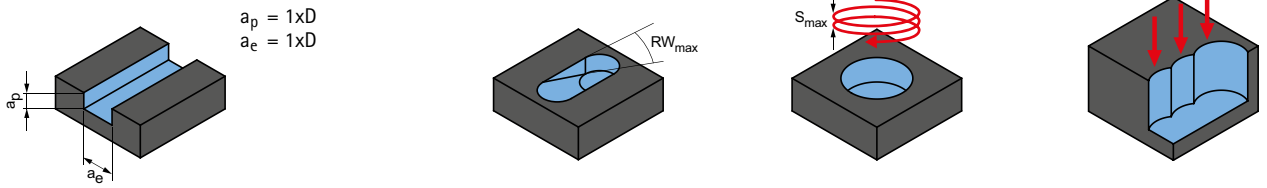

v_c [m/min]	f_z [mm]						Ramps	Helix milling		Drilling	
	Diameter of milling cutter [mm]						RW_{max}	S_{max}	EW_{max}		f_z factor
	5.00	8.00	10.00	12.00	16.00	20.00			G = 1.5	G = 1.8	
610	0.047	0.071	0.086	0.099	0.124	0.144	45°	0.75xD	25°	16°	0.8
405	0.049	0.074	0.090	0.104	0.130	0.151	45°	0.75xD	25°	16°	0.8
325	0.052	0.078	0.094	0.109	0.136	0.158	45°	0.75xD	25°	16°	0.8
235	0.057	0.085	0.103	0.119	0.149	0.172	45°	0.75xD	25°	16°	0.8
235	0.038	0.057	0.068	0.080	0.099	0.115	45°	0.75xD	25°	16°	0.8
175	0.038	0.057	0.068	0.080	0.099	0.115	45°	0.75xD	25°	16°	0.8
295	0.024	0.035	0.043	0.050	0.062	0.072	45°	0.75xD	25°	16°	0.8
80	0.024	0.035	0.043	0.050	0.062	0.072	45°	0.75xD	25°	16°	0.8
120	0.024	0.035	0.043	0.050	0.062	0.072	45°	0.75xD	25°	16°	0.8
365	0.014	0.021	0.026	0.030	0.037	0.043	45°	0.75xD	25°	16°	0.8

Full cutting

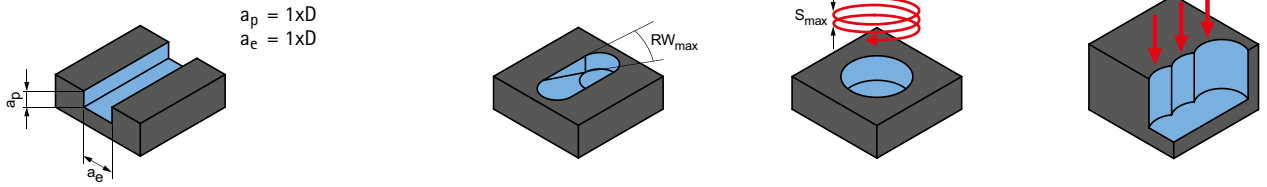

v_c [m/min]	f_z [mm]								Ramps	Helix milling		Grooving	
	Diameter of milling cutter [mm]								RW_{max}	S_{max}	EW_{max}		f_z factor
	5.00	8.00	10.00	12.00	14.00	16.00	18.00	20.00			G = 1.5	G = 1.8	
495	0.045	0.068	0.081	0.093	0.104	0.114	0.123	0.130	45°	0.75xD	25°	16°	0.8
330	0.047	0.071	0.085	0.098	0.109	0.120	0.129	0.137	45°	0.75xD	25°	16°	0.8
265	0.050	0.075	0.089	0.103	0.115	0.125	0.135	0.143	45°	0.75xD	25°	16°	0.8
190	0.054	0.081	0.097	0.112	0.125	0.137	0.147	0.156	45°	0.75xD	25°	16°	0.8
190	0.036	0.054	0.065	0.075	0.083	0.091	0.098	0.104	45°	0.75xD	25°	16°	0.8
145	0.036	0.054	0.065	0.075	0.083	0.091	0.098	0.104	45°	0.75xD	25°	16°	0.8
240	0.023	0.034	0.041	0.047	0.052	0.057	0.061	0.065	45°	0.75xD	25°	16°	0.8
65	0.023	0.034	0.041	0.047	0.052	0.057	0.061	0.065	45°	0.75xD	25°	16°	0.8
100	0.023	0.034	0.041	0.047	0.052	0.057	0.061	0.065	45°	0.75xD	25°	16°	0.8
170	0.014	0.020	0.024	0.028	0.031	0.034	0.037	0.039	45°	0.75xD	25°	16°	0.8

Explanation of terms:

RW_{max} = Maximum angle of the ramp

S_{max} = Maximum slope of the helix

G = Ratio of circular pocket \emptyset when plunging into the tool \emptyset

E.g.: Tool \emptyset 12 mm at G=1.5 results in a pocket \emptyset of 18 mm

EW_{max} = Slope angle of the helix (results from G and S_{max})

The specified machining values are guide values.

The optimum data for the respective machining task should be determined in the trial or during machining.

Cutting data recommendations for shoulder milling cutters

Feed and cutting speed

OptiMill-Hardened | SCM102, 103

MMG*		Workpiece material	Strength/hardness [N/mm ²] [HRC]	Cooling			
				MQL/Air	Dry	KSS	
P	P1	P1.1	Structural, machining, case hardened and tempering steels, unalloyed	< 700	✓	✓	✓
		P1.2	Structural, machining, case hardened and tempering steels, unalloyed	< 1,200	✓	✓	✓
	P2	P2.1	Nitriding, hardening and tempering steels, alloyed	< 900	✓	✓	✓
		P2.2	Nitriding, hardening and tempering steels, alloyed	< 1,400	✓	✓	✓
	P3	P3.1	Tool, bearing, spring and high-speed steels**	< 800	✓	✓	✓
		P3.2	Tool, bearing, spring and high-speed steels**	< 1,000	✓	✓	✓
		P3.3	Tool, bearing, spring and high-speed steels**	< 1,500	✓	✓	✓
	P4	P4.1	Stainless steels, ferritic and martensitic		✓		✓
	P5	P5.1	Cast steel		✓		✓
	P6	P6.1	Stainless cast steels, ferritic and martensitic		✓		✓
H	H1	H1.1	Hardened steel/cast steel	< 44	✓	✓	
		H1.2	Hardened steel/cast steel	< 55	✓	✓	
	H2	H2.1	Hardened steel/cast steel	< 60	✓		

OptiMill-Hardened | SCM102, 103

MMG*		Workpiece material	Strength/hardness [N/mm ²] [HRC]	Cooling			
				MQL/Air	Dry	KSS	
P	P1	P1.1	Structural, machining, case hardened and tempering steels, unalloyed	< 700	✓	✓	✓
		P1.2	Structural, machining, case hardened and tempering steels, unalloyed	< 1,200	✓	✓	✓
	P2	P2.1	Nitriding, hardening and tempering steels, alloyed	< 900	✓	✓	✓
		P2.2	Nitriding, hardening and tempering steels, alloyed	< 1,400	✓	✓	✓
	P3	P3.1	Tool, bearing, spring and high-speed steels**	< 800	✓	✓	✓
		P3.2	Tool, bearing, spring and high-speed steels**	< 1,000	✓	✓	✓
		P3.3	Tool, bearing, spring and high-speed steels**	< 1,500	✓	✓	✓
	P4	P4.1	Stainless steels, ferritic and martensitic		✓		✓
	P5	P5.1	Cast steel		✓		✓
	P6	P6.1	Stainless cast steels, ferritic and martensitic		✓		✓
H	H1	H1.1	Hardened steel/cast steel	< 44	✓	✓	
		H1.2	Hardened steel/cast steel	< 55	✓	✓	
	H2	H2.1	Hardened steel/cast steel	< 60	✓		

* MAPAL machining groups

** If the alloy parts Cr, Mo, Ni, V, W in total > 8%, then select the next highest MAPAL machining group.

Roughing

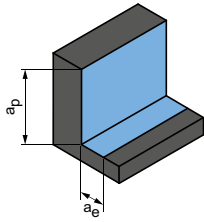

Plunge angle
1.0° - 3.0°

a_p [mm] in % of D	a_e [mm] in % of D	v_c [m/min]	f_z [mm]								
			Diameter of milling cutter [mm]								
			4.00	5.00	6.00	8.00	10.00	12.00	16.00	20.00	
50	8	180 - 200	0.032	0.040	0.048	0.055	0.075	0.095	0.110	0.140	
50	8	160 - 180	0.030	0.038	0.046	0.052	0.071	0.090	0.105	0.133	
50	8	170 - 190	0.032	0.040	0.048	0.055	0.075	0.095	0.110	0.140	
50	8	150 - 170	0.030	0.038	0.046	0.052	0.071	0.090	0.105	0.133	
50	8	170 - 190	0.032	0.040	0.048	0.055	0.075	0.095	0.110	0.140	
50	7	150 - 170	0.030	0.038	0.046	0.052	0.071	0.090	0.105	0.133	
50	7	130 - 150	0.027	0.034	0.041	0.047	0.064	0.081	0.094	0.119	
50	7	130 - 150	0.027	0.034	0.041	0.047	0.064	0.081	0.094	0.119	
50	7	130 - 150	0.027	0.034	0.041	0.047	0.064	0.081	0.094	0.119	
50	8	140 - 160	0.029	0.036	0.043	0.050	0.068	0.086	0.099	0.126	
50	2	100 - 125	0.027	0.034	0.041	0.047	0.064	0.081	0.094	0.119	
50	1.5	80 - 100	0.022	0.028	0.034	0.039	0.053	0.067	0.077	0.098	
50	1.2	60 - 80	0.019	0.024	0.029	0.033	0.045	0.057	0.066	0.084	

Next table:
Finishing

Finishing

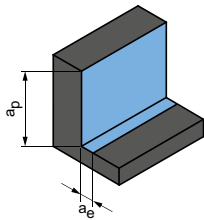

Plunge angle 0.5°
- 1.0°

a_p [mm] in % of D	a_e [mm] in % of D	v_c [m/min]	f_z [mm]								
			Diameter of milling cutter [mm]								
			4.00	5.00	6.00	8.00	10.00	12.00	16.00	20.00	
100	2	200 - 220	0.025	0.030	0.040	0.050	0.065	0.075	0.090	0.105	
100	2	180 - 200	0.024	0.029	0.038	0.048	0.062	0.071	0.086	0.100	
100	2	180 - 200	0.025	0.030	0.040	0.050	0.065	0.075	0.090	0.105	
100	2	160 - 180	0.024	0.029	0.038	0.048	0.062	0.071	0.086	0.100	
100	2	180 - 200	0.025	0.030	0.040	0.050	0.065	0.075	0.090	0.105	
100	2	160 - 180	0.024	0.029	0.038	0.048	0.062	0.071	0.086	0.100	
100	2	140 - 160	0.021	0.026	0.034	0.043	0.055	0.064	0.077	0.089	
100	2	140 - 160	0.021	0.026	0.034	0.043	0.055	0.064	0.077	0.089	
100	2	140 - 160	0.021	0.026	0.034	0.043	0.055	0.064	0.077	0.089	
100	2	150 - 170	0.023	0.027	0.036	0.045	0.059	0.068	0.081	0.095	
100	1.5	110 - 130	0.021	0.026	0.034	0.043	0.055	0.064	0.077	0.089	
100	1.2	90 - 115	0.018	0.021	0.028	0.035	0.046	0.053	0.063	0.074	
100	0.8	70 - 90	0.015	0.018	0.024	0.030	0.039	0.045	0.054	0.063	

The specified machining values are guide values.
The optimum data for the respective machining task should be determined during the test or machining.

Cutting data recommendations for shoulder milling cutters

Feed and cutting speed

OptiMill-Hardened-Finish | SCM104

MMG*	Workpiece material		Strength/hardness [N/mm ²] [HRC]	Cooling			
				MQL/Air	Dry	KSS	
H	H1	H1.1	Hardened steel/cast steel	< 44	✓	✓	
		H1.2	Hardened steel/cast steel	< 55	✓	✓	
	H2	H2.1	Hardened steel/cast steel	< 60	✓		
		H2.2	Hardened steel/cast steel	< 65	✓		
		H2.3	Hardened steel/cast steel	< 68	✓		
	H3	H3.1	Wear-resistant cast / chill casting, GJN		✓	✓	

* MAPAL machining groups

** If the alloy parts Cr, Mo, Ni, V, W in total > 8%, then select the next highest MAPAL machining group.

Finishing

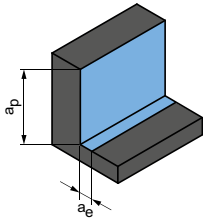

Plunge angle 0.5°
- 1.0°

a_p [mm] in % of D	a_e [mm] in % of D	v_c [m/min]	f_z [mm]									
			Diameter of milling cutter [mm]									
			4.00	5.00	6.00	8.00	10.00	12.00	14.00	16.00	18.00	20.00
100	1.5	110 - 130	0.021	0.026	0.034	0.043	0.055	0.064	0.077	0.089	0.100	0.111
100	1.2	90 - 115	0.018	0.021	0.028	0.035	0.046	0.053	0.063	0.074	0.082	0.092
100	0.8	80 - 100	0.015	0.018	0.024	0.030	0.039	0.045	0.054	0.063	0.071	0.079
100	0.6	70 - 90	0.013	0.015	0.020	0.025	0.033	0.038	0.045	0.053	0.059	0.066
100	0.4	60 - 85	0.010	0.012	0.016	0.020	0.026	0.030	0.036	0.042	0.047	0.052
100	0.8	80 - 100	0.015	0.018	0.024	0.030	0.039	0.045	0.054	0.063	0.071	0.079

The specified machining values are guide values.
The optimum data for the respective machining task should be determined during the test or machining.

Cutting data recommendations for shoulder milling cutters

Feed and cutting speed

OptiMill-Graphite-MT | SCM105, 106

MMG*	Workpiece material	Strength/hardness [N/mm ²] [HRC]	Cooling		
			MQL/Air	Dry	KSS
N N3	N3.1 Graphite, > 8 µm		✓		✓
	N3.2 Graphite, ≤ 8 µm		✓		✓

Groove milling

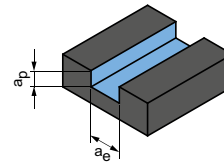

$$a_p = 0.5xD$$

$$a_e = 1xD$$

OptiMill-Diamond type 51 | SHM511, 611, 711

MMG*	Workpiece material	Strength/hardness [N/mm ²] [HRC]	Cooling			Diameter of milling cutter [mm]								
			MQL/Air	Dry	KSS	3.00 - 6.00		8.00 - 10.00		12.00 - 16.00		18.00 - 25.00		
						v _c [m/min]	f _z [mm]	v _c [m/min]	f _z [mm]	v _c [m/min]	f _z [mm]	v _c [m/min]	f _z [mm]	
N	N1	N1.1 Aluminium, unalloyed and alloyed < 3% Si	✓	✓	✓	200	0.10-0.12	500	0.12-0.15	800	0.15-0.20	1.000	0.18-0.23	
		N1.2 Aluminium, alloyed ≤ 7% Si	✓	✓	✓	200	0.10-0.12	500	0.12-0.15	800	0.15-0.20	1.000	0.18-0.23	
		N1.3 Aluminium, alloyed > 7 - 12% Si	✓	✓	✓	200	0.10-0.12	500	0.12-0.15	800	0.15-0.20	1.000	0.18-0.23	
		N1.4 Aluminium, alloyed > 12% Si	✓	✓	✓	200	0.10-0.12	500	0.12-0.15	800	0.15-0.20	1.000	0.18-0.23	
	N2	N2.1 Copper, unalloyed and low alloyed	< 300	✓	✓	✓	200	0.10-0.12	500	0.12-0.15	800	0.15-0.20	1.000	0.18-0.23
		N2.2 Copper, alloyed	> 300	✓	✓	✓	200	0.10-0.12	500	0.12-0.15	800	0.15-0.20	1.000	0.18-0.23
		N2.3 Brass, bronze, gunmetal	< 1,200	✓	✓	✓	200	0.10-0.12	500	0.12-0.15	800	0.15-0.20	1.000	0.18-0.23
	N4	N4.1 Plastic, thermoplastics												
		N4.2 Plastic, duroplastics		✓	✓	✓	200	0.10-0.12	500	0.12-0.15	800	0.15-0.20	1.000	0.18-0.23
		N4.3 Plastic, foam materials												
C	C1.1 Plastic range, reinforced with aramid fibre (AFK)													
	C1.2 Plastic range (duroplastic), CFK/GFK		✓	✓	✓	200	0.10-0.12	500	0.12-0.15	800	0.15-0.20	1.000	0.18-0.23	
	C1.3 Plastic range (thermoplastic), CFK/GFK		✓	✓	✓	200	0.10-0.12	500	0.12-0.15	800	0.15-0.20	1.000	0.18-0.23	
	C2.1 Carbon range, reinforced with carbon fibre (CFC)		✓	✓	✓	200	0.10-0.12	500	0.12-0.15	800	0.15-0.20	1.000	0.18-0.23	

* MAPAL machining groups

Roughing

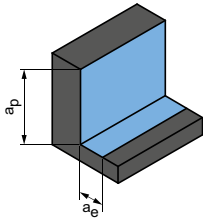

	a_p [mm]	a_e [mm]	v_c [m/min]	f_z [mm]						
				Diameter of milling cutter [mm]						
				3.00	4.00	5.00	6.00	8.00	10.00	12.00
	1xD	0.4xD	500-600	0.200	0.250	0.280	0.300	0.350	0.380	0.400
	1xD	0.4xD	400-500	0.200	0.250	0.280	0.300	0.350	0.380	0.400

Roughing

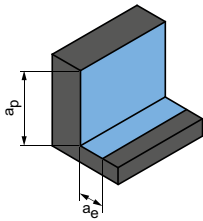

$a_p = 0.5xD$
 $a_e = 0.25xD$

Finishing

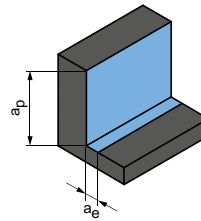

$a_p = 0.5xD$
 $a_e = 0.1xD$

Diameter of milling cutter [mm]								Diameter of milling cutter [mm]							
3.00 - 6.00		8.00 - 10.00		12.00 - 16.00		18.00 - 25.00		3.00 - 6.00		8.00 - 10.00		12.00 - 16.00		18.00 - 25.00	
v_c [m/min]	f_z [mm]	v_c [m/min]	f_z [mm]	v_c [m/min]	f_z [mm]	v_c [m/min]	f_z [mm]	v_c [m/min]	f_z [mm]	v_c [m/min]	f_z [mm]	v_c [m/min]	f_z [mm]	v_c [m/min]	f_z [mm]
240	0.10-0.12	480	0.12-0.16	720	0.16-0.20	960	0.16-0.22	300	0.12-0.15	600	0.15-0.20	900	0.20-0.25	1.200	0.20-0.27
240	0.10-0.12	480	0.12-0.16	720	0.16-0.20	960	0.16-0.22	300	0.12-0.15	600	0.15-0.20	900	0.20-0.25	1.200	0.20-0.27
240	0.10-0.12	480	0.12-0.16	720	0.16-0.20	960	0.16-0.22	300	0.12-0.15	600	0.15-0.20	900	0.20-0.25	1.200	0.20-0.27
240	0.10-0.12	480	0.12-0.16	720	0.16-0.20	960	0.16-0.22	300	0.12-0.15	600	0.15-0.20	900	0.20-0.25	1.200	0.20-0.27
240	0.10-0.12	480	0.12-0.16	720	0.16-0.20	960	0.16-0.22	300	0.12-0.15	600	0.15-0.20	900	0.20-0.25	1.200	0.20-0.27
240	0.10-0.12	480	0.12-0.16	720	0.16-0.20	960	0.16-0.22	300	0.12-0.15	600	0.15-0.20	900	0.20-0.25	1.200	0.20-0.27
240	0.10-0.12	480	0.12-0.16	720	0.16-0.20	960	0.16-0.22	300	0.12-0.15	600	0.15-0.20	900	0.20-0.25	1.200	0.20-0.27
240	0.10-0.12	480	0.12-0.16	720	0.16-0.20	960	0.16-0.22	300	0.12-0.15	600	0.15-0.20	900	0.20-0.25	1.200	0.20-0.27
240	0.10-0.12	480	0.12-0.16	720	0.16-0.20	960	0.16-0.22	300	0.12-0.15	600	0.15-0.20	900	0.20-0.25	1.200	0.20-0.27
240	0.10-0.12	480	0.12-0.16	720	0.16-0.20	960	0.16-0.22	300	0.12-0.15	600	0.15-0.20	900	0.20-0.25	1.200	0.20-0.27

The specified machining values are guide values.
The optimum data for the respective machining task should be determined during the test or machining.





TROCHOIDAL MILLING CUTTER

Universal application

OptiMill-Tro-Uni 214

Steel, stainless steel and cast iron

OptiMill-Tro-PM 217

Hardened steel

OptiMill-Tro-H 221

Technical appendix

Cutting data recommendations 222

Determination of cutting data | working depth 548

OptiMill®-Tro-Uni

Shoulder milling cutter, 3xD design with neck, includes chip breaker
SCM580 | SCM940

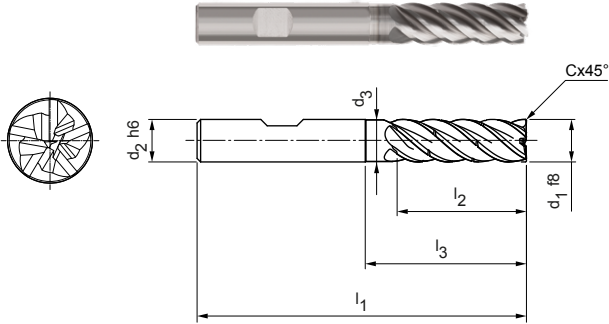

Design:

- Diameter of milling cutter: 4.00 - 20.00 mm
- Cutting material: HP213
- Number of cutting edges: 5
- Helix angle: ~ 41°
- Balancing quality: Cutting edge portion balanced on G2.5 according to DIN ISO1940-G2.5
- Special features: Unequal spacing, chip breaker

Application:

Design with chip breaker for optimum chip control. Ensures chips are shortened.

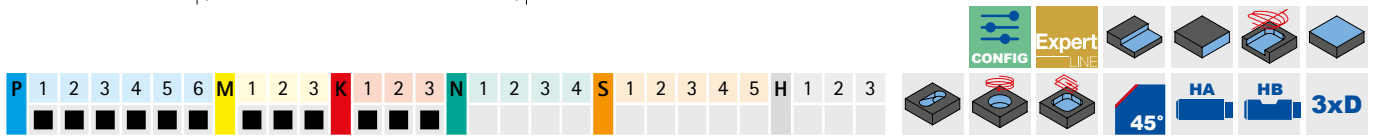

Preferred series in stock

Dimensions							z	Chip breaker	Specification	Order no.
d ₁ f8	d ₂ h6	d ₃	l ₁	l ₂	l ₃	Cx45°				
4,00	6	3,9	62	16	23	0,08	5	1	SCM580-0400Z05R-F0008HB-HP213	30615710
5,00	6	4,8	62	17	24	0,10	5	1	SCM580-0500Z05R-F0010HB-HP213	30564623
6,00	6	5,8	62	18	25	0,12	5	1	SCM580-0600Z05R-F0012HB-HP213	30564624
8,00	8	7,8	68	24	30	0,16	5	1	SCM580-0800Z05R-F0016HB-HP213	30564625
10,00	10	9,8	80	30	35	0,20	5	1	SCM580-1000Z05R-F0020HB-HP213	30564626
12,00	12	11,8	93	36	45	0,24	5	2	SCM940-1200Z05R-F0024HB3-HP213	31054530
14,00	14	13,8	99	42	50	0,28	5	2	SCM940-1400Z05R-F0028HB3-HP213	31054531
16,00	16	15,8	108	48	55	0,32	5	2	SCM940-1600Z05R-F0032HB3-HP213	31054532
20,00	20	19,8	126	60	70	0,40	5	2	SCM940-2000Z05R-F0040HB3-HP213	31054533

Configurable features



Shank form:
Shank form: HA

Specification up to ø 10 mm:
SCM580-0400Z05R-F0008[shank form]-HP213

Specification from ø 12 mm:
SCM940-1200Z05R-F0024[shank form]3-HP213

Example:

SCM580-0400Z05R-F0008HA-HP213

Shank form HA

Dimensions in mm.

For cutting data recommendations, see end of chapter.

Special designs and other coatings available upon request.

OptiMill®-Tro-Uni

Shoulder milling cutter, 4xD design, with chip breaker
SCM940

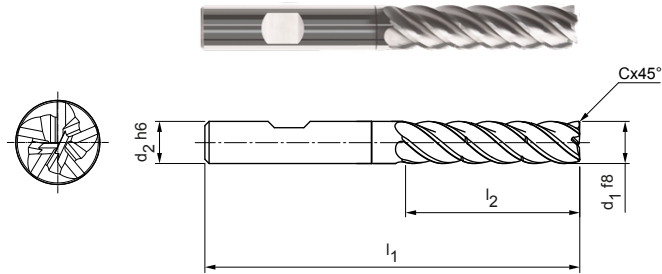

Design:

Diameter of milling cutter: 5.00 - 20.00 mm
 Cutting material: HP209
 Number of cutting edges: 5
 Helix angle: ~ 41°
 Balancing quality: Cutting edge portion balanced on G2.5 according to DIN ISO1940-G2.5
 Special features: Unequal spacing, chip breaker

Application:

Design with chip breaker for optimum chip control. Ensures chips are shortened.

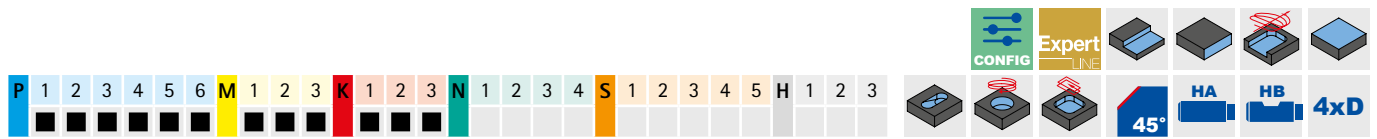

Preferred series in stock

Dimensions					z	Chip breaker	Specification	Order no.
d ₁ f8	d ₂ h6	l ₁	l ₂	Cx45°				
5,00	6	66	20	0,10	5	2	SCM940-0500Z05R-F0010HB4-HP209	31054534
6,00	6	66	24	0,12	5	2	SCM940-0600Z05R-F0012HB4-HP209	31054535
8,00	8	74	32	0,16	5	2	SCM940-0800Z05R-F0016HB4-HP209	31054536
10,00	10	89	40	0,20	5	2	SCM940-1000Z05R-F0020HB4-HP209	31054537
12,00	12	100	48	0,24	5	2	SCM940-1200Z05R-F0024HB4-HP209	31054538
16,00	16	123	64	0,32	5	2	SCM940-1600Z05R-F0032HB4-HP209	31054540
20,00	20	140	80	0,40	5	2	SCM940-2000Z05R-F0040HB4-HP209	31054541

Available on request

14,00	14	108	56	0,28	5	2	SCM940-1400Z05R-F0028HB4-HP209	31054539
-------	----	-----	----	------	---	---	--------------------------------	----------

Configurable features

Shank form:
Shank form: HA

Specification:
SCM940-0500Z05R-F0010[shank form]4-HP209

Example:

SCM940-0500Z05R-F0010**HA**4-HP209

Shank form HA

Dimensions in mm.

For cutting data recommendations, see end of chapter.

Special designs and other coatings available upon request.

OptiMill®-Tro-Uni

Shoulder milling cutter, 5xD design, with chip breaker
SCM940

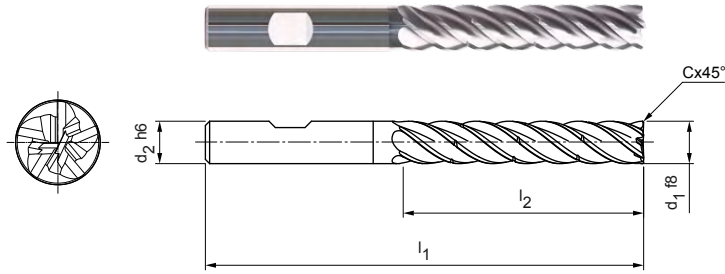

Design:

Diameter of milling cutter: 8.00 - 20.00 mm
 Cutting material: HP209
 Number of cutting edges: 5
 Helix angle: ~ 41°
 Balancing quality: Cutting edge portion balanced on G2.5 according to DIN ISO1940-G2.5
 Special features: Unequal spacing, chip breaker

Application:

Design with chip breaker for optimum chip control. Ensures chips are shortened.

Product configuration bar: P 1 2 3 4 5 6 M 1 2 3 K 1 2 3 N 1 2 3 4 S 1 2 3 4 5 H 1 2 3

Icons: CONFIG, Expert LINE, 45°, HA, HB, 5xD

Preferred series in stock

Dimensions					z	Chip breaker	Specification	Order no.
d1 f8	d2 h6	l1	l2	Cx45°				
8,00	8	81	40	0,16	5	3	SCM940-0800Z05R-F0016HB5-HP209	31054542
10,00	10	96	50	0,20	5	3	SCM940-1000Z05R-F0020HB5-HP209	31054543
12,00	12	112	60	0,24	5	3	SCM940-1200Z05R-F0024HB5-HP209	31054544
16,00	16	136	80	0,32	5	3	SCM940-1600Z05R-F0032HB5-HP209	31054546
20,00	20	160	100	0,40	5	3	SCM940-2000Z05R-F0040HB5-HP209	31054547

Available on request

14,00	14	122	70	0,28	5	3	SCM940-1400Z05R-F0028HB5-HP209	31054545
-------	----	-----	----	------	---	---	--------------------------------	----------

Configurable features

Shank form:
Shank form: HA

Specification:
SCM940-0800Z05R-F0016[shank form]5-HP209

Example:

SCM940-0800Z05R-F0016HA5-HP209

Shank form HA

Dimensions in mm.

For cutting data recommendations, see end of chapter.

Special designs and other coatings available upon request.

OptiMill®-Tro-PM

Shoulder milling cutter, 2xD design with neck
SCM820

Design:

Diameter of milling cutter: 4.00 - 25.00 mm
 Cutting material: HP723
 Number of cutting edges: 7
 Helix angle: ~ 40°
 Balancing quality: Cutting edge portion balanced on G2.5 according to DIN ISO1940-G2.5
 Special features: Unequal spacing

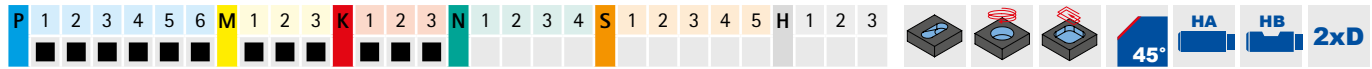
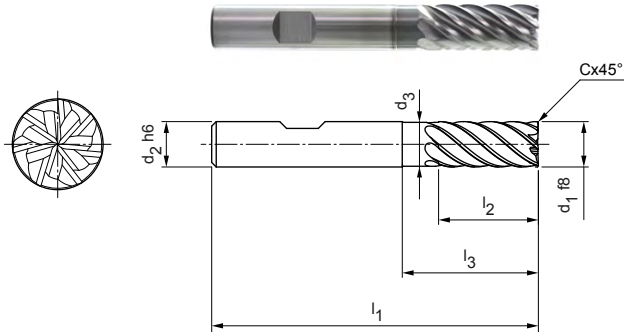

Preferred series in stock

Dimensions							z	Specification	Order no.
d ₁ f8	d ₂ h6	d ₃	l ₁	l ₂	l ₃	Cx45°			
4,00	6	-	57	11	-	0,08	7	SCM820-0400Z07R-F0008HB2-HP723	30855545
5,00	6	-	57	13	-	0,10	7	SCM820-0500Z07R-F0010HB2-HP723	30855546
6,00	6	5,8	57	13	19	0,12	7	SCM820-0600Z07R-F0012HB2-HP723	30855547
8,00	8	7,8	63	19	25	0,16	7	SCM820-0800Z07R-F0016HB2-HP723	30855548
10,00	10	9,8	72	22	30	0,20	7	SCM820-1000Z07R-F0020HB2-HP723	30855549
12,00	12	11,8	83	26	36	0,24	7	SCM820-1200Z07R-F0024HB2-HP723	30855550
16,00	16	15,8	92	32	42	0,32	7	SCM820-1600Z07R-F0032HB2-HP723	30855552
20,00	20	19,8	104	41	52	0,40	7	SCM820-2000Z07R-F0040HB2-HP723	30855554

Available on request

14,00	14	13,8	83	26	36	0,28	7	SCM820-1400Z07R-F0028HB2-HP723	30855551
18,00	18	17,8	92	32	42	0,36	7	SCM820-1800Z07R-F0036HB2-HP723	30855553
25,00	25	24,5	125	50	65	0,50	7	SCM820-2500Z07R-F0050HB2-HP723	30855555

Configurable features



Shank form:
Shank form: HA



Specification:
SCM820-0400Z07R-F0008[shank form]2-HP723

Example:

SCM820-0400Z07R-F0008HA2-HP723

Shank form HA

Dimensions in mm.

For cutting data recommendations, see end of chapter.

Special designs and other coatings available upon request.

OptiMill®-Tro-PM

Shoulder milling cutter, 3xD design with neck, includes chip breaker
SCM820 | SCM930

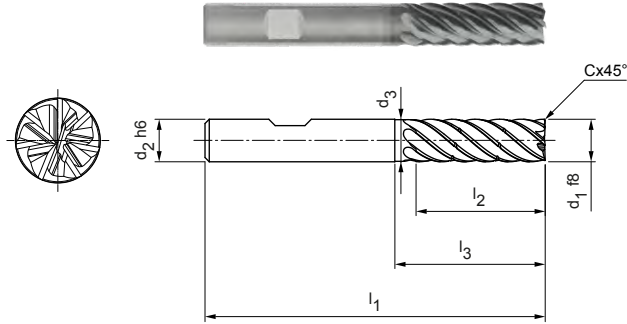

Design:

- Diameter of milling cutter: 4.00 - 20.00 mm
- Cutting material: HP723
- Number of cutting edges: 7
- Helix angle: ~ 40°
- Balancing quality: Cutting edge portion balanced on G2.5 according to DIN ISO1940-G2.5
- Special features: Unequal spacing, chip breaker

Application:

Design with chip breaker for optimum chip control. Ensures chips are shortened.

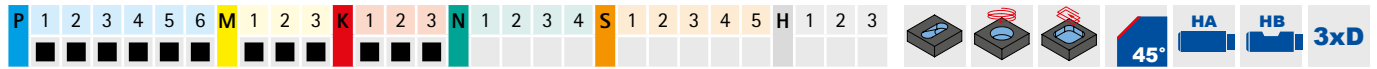

Preferred series in stock

Dimensions							z	Chip breaker	Specification	Order no.
d ₁ f8	d ₂ h6	d ₃	l ₁	l ₂	l ₃	Cx45°				
4,00	6	3,9	62	16	23	0,08	7	1	SCM820-0400Z07R-F0008HB3-HP723	30855556
5,00	6	4,8	62	17	24	0,10	7	1	SCM820-0500Z07R-F0010HB3-HP723	30855557
6,00	6	5,8	62	18	25	0,12	7	1	SCM820-0600Z07R-F0012HB3-HP723	30855558
8,00	8	7,8	68	24	30	0,16	7	1	SCM820-0800Z07R-F0016HB3-HP723	30855559
10,00	10	9,8	80	30	35	0,20	7	1	SCM820-1000Z07R-F0020HB3-HP723	30855560
12,00	12	11,8	93	36	45	0,24	7	2	SCM930-1200Z07R-F0024HB3-HP723	31054500
16,00	16	15,8	108	48	55	0,32	7	2	SCM930-1600Z07R-F0032HB3-HP723	31054502
20,00	20	19,8	126	60	70	0,40	7	2	SCM930-2000Z07R-F0040HB3-HP723	31054503

Available on request

14,00	14	13,8	99	42	50	0,28	7	2	SCM930-1400Z07R-F0028HB3-HP723	31054501
-------	----	------	----	----	----	------	---	---	--------------------------------	----------

Configurable features

Shank form:
Shank form: HA

Specification up to ø 10 mm:
SCM820-0400Z07R-F0008[shank form]3-HP723

Specification from ø 12 mm:
SCM930-1200Z07R-F0024[shank form]3-HP723

Example:

SCM820-0400Z07R-F0008HA3-HP723



Dimensions in mm.

For cutting data recommendations, see end of chapter.

Special designs and other coatings available upon request.

OptiMill®-Tro-PM

Shoulder milling cutter, 4xD design, with chip breaker
SCM930

Design:

Diameter of milling cutter: 6.00 - 20.00 mm
Cutting material: HP210
Number of cutting edges: 7
Helix angle: ~ 38°
Special features: Unequal spacing, chip breaker

Application:

Design with chip breaker for optimum chip control. Ensures chips are shortened.

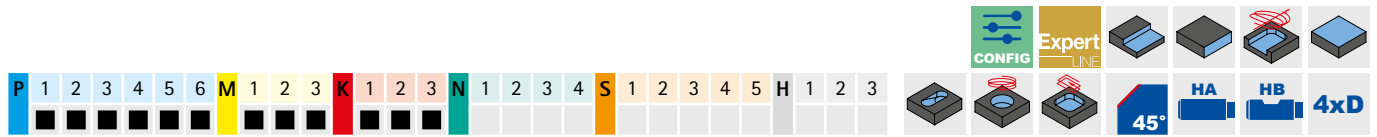
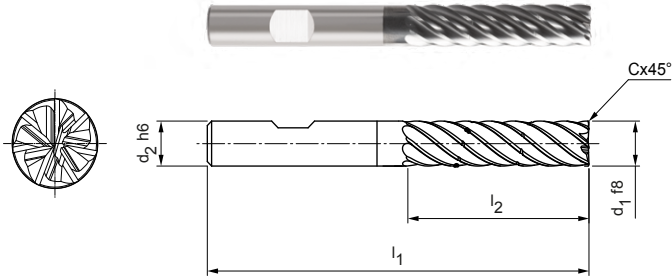

Preferred series in stock

Dimensions					z	Chip breaker	Specification	Order no.
d ₁ f8	d ₂ h6	l ₁	l ₂	Cx45°				
6,00	6	66	24	0,12	7	2	SCM930-0600Z07R-F0012HB4-HP210	31054505
8,00	8	74	32	0,16	7	2	SCM930-0800Z07R-F0016HB4-HP210	31054506
10,00	10	89	40	0,20	7	2	SCM930-1000Z07R-F0020HB4-HP210	31054507
12,00	12	100	48	0,24	7	2	SCM930-1200Z07R-F0024HB4-HP210	31054508
16,00	16	123	64	0,32	7	2	SCM930-1600Z07R-F0032HB4-HP210	31054510
20,00	20	140	80	0,40	7	2	SCM930-2000Z07R-F0040HB4-HP210	31054511

Available on request

14,00	14	108	56	0,28	7	2	SCM930-1400Z07R-F0028HB4-HP210	31054509
-------	----	-----	----	------	---	---	--------------------------------	----------

Configurable features



Shank form:
Shank form: HA



Specification:
SCM930-0600Z07R-F0012[shank form]4-H210

Example:

SCM930-0600Z07R-F0012HA4-HP210

Shank form HA

Dimensions in mm.

For cutting data recommendations, see end of chapter.

Special designs and other coatings available upon request.

OptiMill®-Tro-PM

Shoulder milling cutter, 5xD design, with chip breaker
SCM930

Design:

Diameter of milling cutter: 8.00 - 20.00 mm
Cutting material: HP210
Number of cutting edges: 7
Helix angle: ~ 36°
Special features: Unequal spacing, chip breaker

Application:

Design with chip breaker for optimum chip control. Ensures chips are shortened.

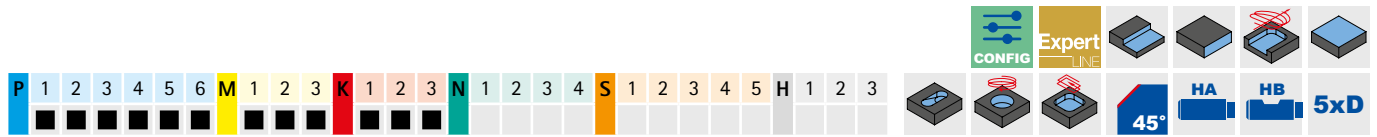
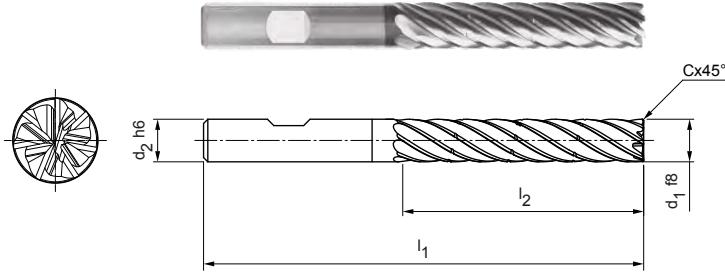

Preferred series in stock

Dimensions					z	Chip breaker	Specification	Order no.
d ₁ f8	d ₂ h6	l ₁	l ₂	Cx45°				
8,00	8	81	40	0,16	7	3	SCM930-0800Z07R-F0016HB5-HP210	31054512
10,00	10	96	50	0,20	7	3	SCM930-1000Z07R-F0020HB5-HP210	31054513
12,00	12	112	60	0,24	7	3	SCM930-1200Z07R-F0024HB5-HP210	31054514
16,00	16	136	80	0,32	7	3	SCM930-1600Z07R-F0032HB5-HP210	31054516
20,00	20	160	100	0,40	7	3	SCM930-2000Z07R-F0040HB5-HP210	31054517

Available on request

14,00	14	122	70	0,28	7	3	SCM930-1400Z07R-F0028HB5-HP210	31054515
-------	----	-----	----	------	---	---	--------------------------------	----------

Configurable features

Shank form:
Shank form: HA

Specification:
SCM590-0400Z05R-F0008[shank form]5-HP210

Example:

SCM590-0400Z05R-F0008HA5-HP210

Shank form HA

Dimensions in mm.

For cutting data recommendations, see end of chapter.

Special designs and other coatings available upon request.

OptiMill®-Tro-H

Shoulder milling cutter, 3xD design with neck, includes chip breaker
SCM920

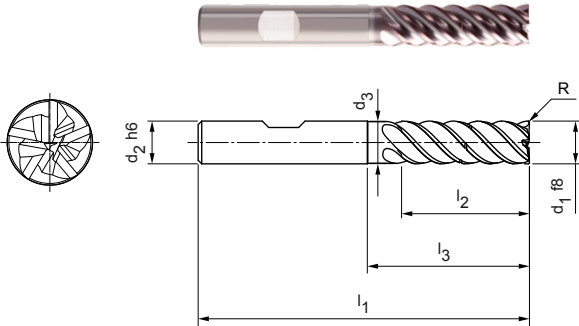

Design:

Diameter of milling cutter: 6.00 – 25.00 mm
Cutting material: HP827
Number of cutting edges: 5
Helix angle: 41°-42°
Balancing quality: Cutting edge portion balanced on G2.5 according to DIN ISO1940-G2.5

Special features: Unequal spacing, chip breaker

Application:

Design with chip breaker for optimum chip control. Ensures chips are shortened.

CONFIG Expert LINE

P 1 2 3 4 5 6 M 1 2 3 K 1 2 3 N 1 2 3 4 S 1 2 3 4 5 H 1 2 3

CR HA HB 3xD

Preferred series in stock

Dimensions							z	Chip breaker	Specification	Order no.
d ₁ f8	d ₂ h6	d ₃	l ₁	l ₂	l ₃	R				
6,00	6	5,8	62	18	25	0,1	5	1	SCM920-0600Z05R-R0010HB-HP827	31053921
8,00	8	7,8	68	24	30	0,2	5	1	SCM920-0800Z05R-R0020HB-HP827	31053922
10,00	10	9,8	80	30	35	0,2	5	1	SCM920-1000Z05R-R0020HB-HP827	31053923
12,00	12	11,8	93	36	45	0,3	5	1	SCM920-1200Z05R-R0030HB-HP827	31053924
14,00	14	13,8	99	42	50	0,3	5	1	SCM920-1400Z05R-R0030HB-HP827	31053925
16,00	16	15,8	108	48	55	0,3	5	1	SCM920-1600Z05R-R0030HB-HP827	31053926
20,00	20	19,8	126	60	70	0,3	5	1	SCM920-2000Z05R-R0030HB-HP827	31053928

Available on request

18,00	18	17,8	117	54	67	0,3	5	1	SCM920-1800Z05R-R0030HB-HP827	31053927
25,00	25	24,5	150	75	92	0,4	5	1	SCM920-2500Z05R-R0040HB-HP827	31053929

Configurable features

Shank form:
Shank form: HA

Specification:
SCM920-0600Z05R-R0010[shank form]-HP827

Example:

SCM920-0600Z05R-R0010HA-HP827

Shank form HA

Dimensions in mm.

For cutting data recommendations, see end of chapter.

Special designs and other coatings available upon request.

Cutting data recommendations for trochoidal milling cutters

Feed and cutting speed

OptiMill-Tro-Uni | SCM580, 940

OptiMill-Tro-PM | SCM820, 930

MMG*	Workpiece material	Strength/hardness [N/mm ²] [HRC]	Cooling			
			MQL/Air	Dry	KSS	
P	P1.1	Structural, machining, case hardened and tempering steels, unalloyed	< 700	✓	✓	✓
	P1.2	Structural, machining, case hardened and tempering steels, unalloyed	< 1,200	✓	✓	✓
	P2.1	Nitriding, hardening and tempering steels, alloyed	< 900	✓	✓	✓
	P2.2	Nitriding, hardening and tempering steels, alloyed	< 1,400	✓		✓
	P3.1	Tool, bearing, spring and high-speed steels**	< 800	✓	✓	✓
	P3.2	Tool, bearing, spring and high-speed steels**	< 1,000	✓		✓
	P3.3	Tool, bearing, spring and high-speed steels**	< 1,500	✓		✓
	P4.1	Stainless steels, ferritic and martensitic		✓		✓
	P5.1	Cast steel				
	P6.1	Stainless cast steels, ferritic and martensitic				✓
M	M1.1	Stainless steels, austenitic	< 700	✓		✓
	M1.2	Stainless steels, ferritic/austenitic (duplex)	< 1,000			✓
	M2.1	Stainless cast steel, austenitic	< 700	✓		✓
	M3.1	Stainless cast steel, ferritic/austenitic (duplex)	< 1,000			✓
K	K1.1	Cast iron with lamellar graphite (grey cast iron), GJL	< 300	✓	✓	✓
	K2.1	Cast iron with spheroidal graphite, GJS	< 500	✓	✓	✓
	K2.2	Cast iron with spheroidal graphite, GJS	≤ 800	✓	✓	✓
	K2.3	Cast iron with spheroidal graphite, GJS	> 800	✓	✓	✓
	K3.1	Cast iron with vermicular graphite, GJV; malleable cast iron, GJM	< 500	✓	✓	✓
	K3.2	Cast iron with vermicular graphite, GJV; malleable cast iron, GJM	> 500	✓	✓	✓

Calculation example for 42CrMo4 ø 12 mm:

$$f_z | a_e | h_m \text{ max.} = \frac{D}{100} \cdot \text{See table for value}$$

P2.2	Nitriding, hardening and tempering steels, alloyed	< 1400	✓	✓	280 - 380	1.0 - 1.6	8 - 12	0.56 - 0.68
------	--	--------	---	---	-----------	-----------	--------	-------------

$$1 \quad f_z = \frac{12 \text{ mm}}{100} \cdot 1,2 = 0,144 \text{ mm}$$

$$2 \quad a_e = \frac{12 \text{ mm}}{100} \cdot 10 = 1,2 \text{ mm}$$

$$3 \quad h_m \text{ max.} = \frac{12 \text{ mm}}{100} \cdot 0,6 = 0,072 \text{ mm}$$

Note:

In the case of trochoidal milling, the specified cutting conditions change during the machining process. This also depends on the CAM software used and the machining position of the tool in the workpiece. The feed and cutting width or contact angle are constantly changing during machining in order to achieve, as far as is possible, the most constant average chip thickness depending on the contour.

* MAPAL machining groups

** If the alloy parts Cr, Mo, Ni, V, W in total > 8%, then select the next highest MAPAL machining group.

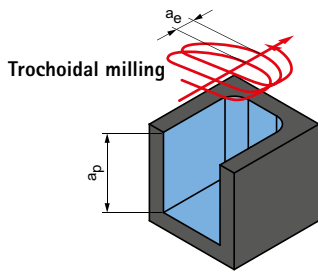

a_p = depending on max. machining depth of the tool
 a_e = depending on the workpiece material

v_c [m/min]	f_z [mm] in % of D	a_e [mm] in % of D	h_m max. [mm] in % of D	Machining example	
380 - 520	1.4 - 2.0	14 - 18	0.66 - 0.80	16MnCr5 $\varnothing = 12$ mm $v_c = 500$ m/min $f_z = 0.28$ mm $a_e = 1.8$ mm $a_p = 32$ mm	42CrMo4 $\varnothing = 12$ mm $v_c = 375$ m/min $f_z = 0.17$ mm $a_e = 1.2$ mm $a_p = 32$ mm
320 - 460	1.2 - 1.8	12 - 16	0.62 - 0.76		
340 - 480	1.2 - 1.8	10 - 14	0.58 - 0.71		
280 - 380	1.0 - 1.6	8 - 12	0.56 - 0.68		
250 - 360	1.1 - 1.7	9 - 15	0.56 - 0.67		
230 - 340	0.9 - 1.5	8 - 13	0.54 - 0.64		
210 - 320	0.8 - 1.4	6 - 12	0.52 - 0.62		
180 - 260	0.8 - 1.2	6 - 12	0.50 - 0.60		
220 - 300	1.2 - 1.8	8 - 12	0.54 - 0.62		
160 - 240	0.8 - 1.4	6 - 12	0.50 - 0.60	X5CrNi18-8 $\varnothing = 12$ mm $v_c = 180$ m/min $f_z = 0.09$ mm	$a_e = 1.2$ mm $a_p = 32$ mm
140 - 220	0.6 - 1.0	5 - 10	0.48 - 0.60		
110 - 180	0.6 - 1.0	5 - 10	0.46 - 0.58		
130 - 200	0.8 - 1.2	6 - 12	0.52 - 0.60		
120 - 180	0.8 - 1.2	5 - 10	0.46 - 0.56		
400 - 500	2.0 - 2.6	15 - 20	0.64 - 0.78		
340 - 500	1.8 - 2.4	12 - 16	0.62 - 0.7		
300 - 440	1.6 - 2.2	10 - 14	0.58 - 0.68		
180 - 260	1.4 - 2.0	8 - 12	0.56 - 0.68		
280 - 360	1.6 - 2.2	10 - 16	0.6 - 0.68		
210 - 340	1.4 - 2.0	10 - 16	0.58 - 0.66		

Correction factors

Factor	v_c			a_e	h_m max.
	P	K	M		
2xD	1,10		1,05	1,05	1,05
3xD	1,00		1,00	1,00	1,00
4xD	0,85		0,92	0,90	0,94
5xD	0,60		0,80	0,80	0,87

Note:

To determine cutting data, please observe the notes on page 548-551.

The specified machining values are guide values.

The optimum data for the respective machining task should be determined during the test or machining.

Cutting data recommendations for trochoidal milling cutters

Feed and cutting speed

OptiMill-Tro-H | SCM920

MMG*		Workpiece material	Strength/hardness [N/mm ²] [HRC]	Cooling		
				MQL/Air	Dry	KSS
H	H1.1	Hardened steel / cast steel	< 44 HRC	✓	✓	
	H1.2	Hardened steel / cast steel	< 55 HRC	✓	✓	
	H2.1	Hardened steel / cast steel	< 60 HRC	✓	✓	
	H2.2	Hardened steel / cast steel	< 65 HRC	✓	✓	
	H2.3	Hardened steel / cast steel	< 68 HRC	✓	✓	
	H3	H3.1	Wear-resistant cast / chill casting, GJN		✓	

Note:

In the case of trochoidal milling, the specified cutting conditions change during the machining process. This also depends on the CAM software used and the machining position of the tool in the workpiece. The feed and cutting width or contact angle are constantly changing during machining in order to achieve, as far as is possible, the most constant average chip thickness depending on the contour.

v_c [m/min]	f_z [mm] in % of D	a_e [mm] in % of D	h_m max. [mm] in % of D	Machining example
100 - 160	0.48 - 0.67	6 - 10	0.38 - 0.50	90MnCrV8 $\varnothing = 12$ mm $v_c = 110$ m/min $f_z = 0.052$ mm $h_m = 0.04$ mm $a_e = 1$ mm
80 - 140	0.45 - 0.65	4 - 8	0.28 - 0.36	
60 - 120	0.4 - 0.52	3 - 6	0.27 - 0.34	
50 - 110	0.37 - 0.5	3 - 5	0.26 - 0.33	
50 - 100	0.3 - 0.48	2 - 5	0.25 - 0.32	
60 - 120	0.35 - 0.55	3 - 6	0.28 - 0.34	

The specified machining values are guide values.

The optimum data for the respective machining task should be determined during the test or machining.



ENGRAVING AND DEBURRING

Universal application

OptiMill-Graver	228
OptiMill-Chamfer	229

Technical appendix

Cutting data recommendations	230
Determination of cutting data working depth	548

OptiMill®-Graver

Engravers
SCM107

Design:
 Diameter of milling cutter: 3.00 - 8.00 mm
 Cutting material: HP808
 Number of cutting edges: 1
 Point angle (α): 30° - 90°

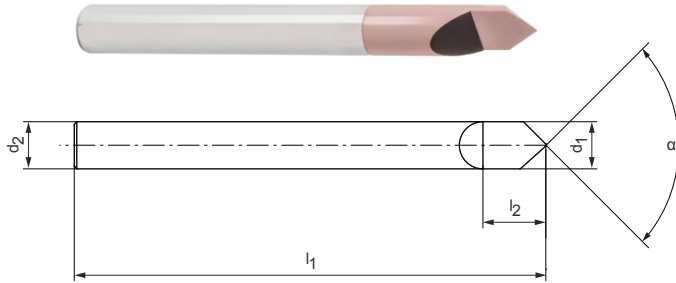

Preferred series in stock

Dimensions			Tip angle [°]	z	Specification	Order no.
d_1	d_2	l_1				
3,00	4	50	30	1	SCM107-0300Z01R-G0300HA-HP808	31154778
3,00	4	50	40	1	SCM107-0300Z01R-G0400HA-HP808	31154779
4,00	4	50	60	1	SCM107-0400Z01R-G0600HA-HP808	31154780
4,00	4	50	90	1	SCM107-0400Z01R-G0900HA-HP808	31154781
6,00	6	60	60	1	SCM107-0600Z01R-G0600HA-HP808	31154782
6,00	6	60	80	1	SCM107-0600Z01R-G0800HA-HP808	31154783
6,00	6	60	90	1	SCM107-0600Z01R-G0900HA-HP808	31154784
8,00	8	65	60	1	SCM107-0800Z01R-G0600HA-HP808	31154785
8,00	8	65	90	1	SCM107-0800Z01R-G0900HA-HP808	31154786

Dimensions in mm.
 For cutting data recommendations, see end of chapter.
 Special designs and other coatings available upon request.

OptiMill®-Chamfer

Short design
SCM340

Design:

Diameter of milling cutter: 4.00 - 20.00 mm
 Cutting material: HP214
 Number of cutting edges: 4
 Tip angle: 90°
 Helix angle: 0°

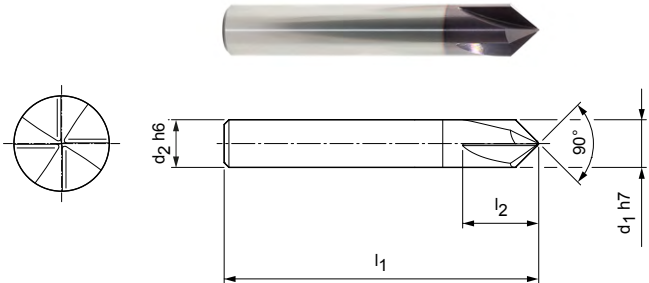

Preferred series in stock

Dimensions				z	Specification	Order no.
d ₁ h7	d ₂ h6	l ₁	l ₂			
4,00	4	54	9	4	SCM340-0400Z04R-HA-HP214	30393635
6,00	6	54	12	4	SCM340-0600Z04R-HA-HP214	30393636
8,00	8	58	15	4	SCM340-0800Z04R-HA-HP214	30393637
10,00	10	66	16	4	SCM340-1000Z04R-HA-HP214	30393638
12,00	12	73	18	4	SCM340-1200Z04R-HA-HP214	30393639
16,00	16	82	25	4	SCM340-1600Z04R-HA-HP214	30393640
20,00	20	92	30	4	SCM340-2000Z04R-HA-HP214	30393641

Configurable features

Shank form:
Shank form: HB

Specification:
SCM340-0400Z04R-[shank form]-HP214

Example:

SCM340-0400Z04R-**HB**-HP214

Shank form HB

Dimensions in mm.

For cutting data recommendations, see end of chapter.

Special designs and other coatings available upon request.

Cutting data recommendations for deburring milling cutters

Feed and cutting speed

OptiMill-Chamfer | SCM340

MMG*		Workpiece material	Strength/hardness [N/mm ²] [HRC]	Cooling		
				Dry	Air/MQL	KSS
P	P1	P1.1 Structural, machining, case hardened and tempering steels, unalloyed	< 700	✓	✓	✓
		P1.2 Structural, machining, case hardened and tempering steels, unalloyed	< 1,200	✓	✓	✓
	P2	P2.1 Nitriding, hardening and tempering steels, alloyed	< 900	✓	✓	✓
		P2.2 Nitriding, hardening and tempering steels, alloyed	< 1,400		✓	✓
	P3	P3.1 Tool, bearing, spring and high-speed steels**	< 800	✓	✓	✓
		P3.2 Tool, bearing, spring and high-speed steels**	< 1,000		✓	✓
		P3.3 Tool, bearing, spring and high-speed steels**	< 1,500		✓	✓
	P4	P4.1 Stainless steels, ferritic and martensitic			✓	✓
	P5	P5.1 Cast steel				✓
	P6	P6.1 Stainless cast steels, ferritic and martensitic				✓
M	M1	M1.1 Stainless steels, austenitic	< 700		✓	✓
		M1.2 Stainless steels, ferritic/austenitic (duplex)	< 1,000			✓
	M2	M2.1 Stainless cast steel, austenitic	< 700		✓	✓
	M3	M3.1 Stainless cast steel, ferritic/austenitic (duplex)	< 1,000			✓
K	K1	K1.1 Cast iron with lamellar graphite (grey cast iron), GJL	< 300	✓	✓	✓
		K2.1 Cast iron with spheroidal graphite, GJS	< 500	✓	✓	✓
		K2.2 Cast iron with spheroidal graphite, GJS	500-800	✓	✓	✓
	K3	K2.3 Cast iron with spheroidal graphite, GJS	> 800	✓	✓	✓
		K3.1 Cast iron with vermicular graphite, GJV; malleable cast iron, GJM	< 500	✓	✓	✓
		K3.2 Cast iron with vermicular graphite, GJV; malleable cast iron, GJM	> 500	✓	✓	✓
N	N1	N1.1 Aluminium, unalloyed and alloyed < 3% Si		✓	✓	✓
		N1.2 Aluminium, alloyed ≤ 7% Si		✓	✓	✓
		N1.3 Aluminium, alloyed > 7 - 12% Si		✓	✓	✓
		N1.4 Aluminium, alloyed > 12% Si		✓	✓	✓
	N2	N2.1 Copper, unalloyed and low alloyed	< 300	✓	✓	✓
		N2.2 Copper, alloyed	> 300	✓	✓	✓
		N2.3 Brass, bronze, gunmetal	< 1,200	✓	✓	✓

* MAPAL machining groups

** If the alloy parts Cr, Mo, Ni, V, W in total > 8%, then select the next highest MAPAL machining group.

Finishing

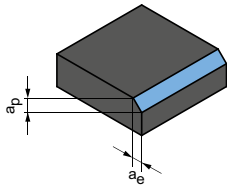

$a_p = 0.1 \times D$
 $a_e = 0.1 \times D$

	v_c [m/min]	f_z [mm]						
		Diameter of milling cutter [mm]						
		4.00	6.00	8.00	10.00	12.00	16.00	20.00
Light Blue	215	0.043	0.061	0.078	0.094	0.108	0.132	0.151
	175	0.040	0.057	0.073	0.088	0.101	0.123	0.141
	195	0.043	0.061	0.078	0.094	0.108	0.132	0.151
	140	0.036	0.051	0.065	0.078	0.090	0.110	0.125
	130	0.041	0.059	0.076	0.091	0.104	0.127	0.146
	120	0.039	0.056	0.072	0.086	0.099	0.121	0.138
	110	0.037	0.053	0.068	0.081	0.093	0.114	0.131
	90	0.028	0.041	0.052	0.063	0.072	0.088	0.100
	130	0.041	0.059	0.076	0.091	0.104	0.127	0.146
Yellow	90	0.020	0.029	0.037	0.044	0.050	0.061	0.070
	75	0.025	0.036	0.046	0.055	0.063	0.077	0.088
	70	0.021	0.030	0.038	0.045	0.052	0.064	0.073
	80	0.027	0.039	0.050	0.059	0.068	0.083	0.095
	75	0.021	0.031	0.039	0.047	0.054	0.066	0.075
Light Orange	290	0.071	0.102	0.131	0.156	0.180	0.220	0.251
	265	0.060	0.087	0.111	0.133	0.153	0.187	0.213
	220	0.050	0.072	0.091	0.109	0.126	0.154	0.176
	120	0.028	0.041	0.052	0.063	0.072	0.088	0.100
	195	0.050	0.072	0.091	0.109	0.126	0.154	0.176
	180	0.043	0.061	0.078	0.094	0.108	0.132	0.151
Light Green	635	0.053	0.076	0.097	0.116	0.133	0.162	0.186
	420	0.055	0.079	0.101	0.121	0.140	0.171	0.195
	335	0.058	0.083	0.106	0.127	0.146	0.179	0.204
	245	0.063	0.091	0.116	0.139	0.160	0.195	0.223
	245	0.042	0.060	0.077	0.093	0.106	0.130	0.149
	180	0.042	0.060	0.077	0.093	0.106	0.130	0.149
	305	0.026	0.038	0.048	0.058	0.066	0.081	0.093

The specified machining values are guide values.
 The optimum data for the respective machining task should be determined during the test or machining.

Cutting data recommendations for engravers

Feed and cutting speed

OptiMill-Graver | SCM107

MMG*	Workpiece material	Strength/hardness [N/mm ²] [HRC]	Cooling		
			Dry	Air/MQL	KSS
P	P1.1	Structural, machining, case hardened and tempering steels, unalloyed	< 700	✓	✓
	P1.2	Structural, machining, case hardened and tempering steels, unalloyed	< 1,200	✓	✓
	P2.1	Nitriding, hardening and tempering steels, alloyed	< 900	✓	✓
	P2.2	Nitriding, hardening and tempering steels, alloyed	< 1,400	✓	✓
	P3.1	Tool, bearing, spring and high-speed steels**	< 800	✓	✓
	P3.2	Tool, bearing, spring and high-speed steels**	< 1,000	✓	✓
	P3.3	Tool, bearing, spring and high-speed steels**	< 1,500	✓	✓
	P4.1	Stainless steels, ferritic and martensitic			✓
	P5.1	Cast steel			✓
P6.1	Stainless cast steels, ferritic and martensitic			✓	
M	M1.1	Stainless steels, austenitic	< 700		✓
	M1.2	Stainless steels, ferritic/austenitic (duplex)	< 1,000		✓
	M2.1	Stainless cast steel, austenitic	< 700		✓
	M3.1	Stainless cast steel, ferritic/austenitic (duplex)	< 1,000		✓
K	K1.1	Cast iron with lamellar graphite (grey cast iron), GJL	< 300	✓	✓
	K2.1	Cast iron with spheroidal graphite, GJS	< 500	✓	✓
	K2.2	Cast iron with spheroidal graphite, GJS	≤ 800	✓	✓
	K2.3	Cast iron with spheroidal graphite, GJS	> 800	✓	✓
	K3.1	Cast iron with vermicular graphite, GJV; malleable cast iron, GJM	< 500	✓	✓
	K3.2	Cast iron with vermicular graphite, GJV; malleable cast iron, GJM	> 500	✓	✓
N	N1.1	Aluminium, unalloyed and alloyed < 3 % Si		✓	✓
	N1.2	Aluminium, alloyed ≤ 7% Si		✓	✓
	N1.3	Aluminium, alloyed > 7 - 12% Si		✓	✓
	N1.4	Aluminium, alloyed > 12% Si		✓	✓
	N2.1	Copper, unalloyed and low alloyed	< 300	✓	✓
	N2.2	Copper, alloyed	> 300	✓	✓
	N2.3	Brass, bronze, gunmetal	< 1,200	✓	✓
S	S1.1	Titanium, titanium alloys	< 400		✓
	S2.1	Titanium, titanium alloys	< 1,200		✓
	S2.2	Titanium, titanium alloys	> 1,200		✓
H	H1.1	Hardened steel / cast steel	< 44 HRC		✓
	H1.2	Hardened steel / cast steel	< 55 HRC		✓
	H2.1	Hardened steel / cast steel	< 60 HRC		✓

* MAPAL machining groups

** If the alloy parts Cr, Mo, Ni, V, W in total > 8%, then select the next highest MAPAL machining group.

	a_p [mm]	v_c [m/min]	f_z [mm]			
			Diameter of milling cutter [mm]			
			3.00	4.00	6.00	8.00
	0.03xD	200–230	0.03	0.05	0.07	0.08
	0.03xD	180–210	0.024	0.04	0.056	0.064
	0.03xD	170–200	0.03	0.05	0.07	0.08
	0.03xD	160–190	0.024	0.04	0.056	0.064
	0.03xD	170–200	0.03	0.05	0.07	0.08
	0.03xD	160–190	0.02	0.03	0.05	0.06
	0.03xD	140–170	0.01	0.02	0.03	0.04
	0.03xD	140–170	0.01	0.02	0.03	0.04
	0.03xD	140–170	0.01	0.02	0.03	0.04
	0.025xD	180–210	0.02	0.03	0.04	0.05
	0.025xD	160–190	0.01	0.02	0.03	0.04
	0.025xD	180–210	0.02	0.03	0.04	0.05
	0.025xD	160–190	0.01	0.02	0.03	0.04
	0.03xD	200–230	0.03	0.05	0.07	0.08
	0.03xD	180–210	0.024	0.04	0.056	0.064
	0.03xD	180–210	0.024	0.04	0.056	0.064
	0.03xD	160–190	0.02	0.03	0.04	0.05
	0.03xD	200–230	0.03	0.05	0.07	0.08
	0.03xD	180–210	0.024	0.04	0.056	0.064
	0.03xD	250–300	0.024	0.04	0.056	0.064
	0.03xD	230–280	0.03	0.05	0.07	0.08
	0.03xD	220–270	0.03	0.05	0.07	0.08
	0.03xD	200–260	0.03	0.05	0.07	0.08
	0.03xD	250–300	0.024	0.04	0.056	0.064
	0.03xD	230–280	0.024	0.04	0.056	0.064
	0.03xD	250–300	0.024	0.04	0.056	0.064
	0.02xD	150–170	0.02	0.03	0.04	0.05
	0.02xD	140–160	0.02	0.03	0.04	0.05
	0.02xD	130–150	0.01	0.02	0.03	0.04
	0.02xD	100–125	0.01	0.02	0.03	0.04
	0.015xD	80–100	0.01	0.02	0.03	0.04
	0.01xD	60–80	0.01	0.02	0.03	0.04

The specified machining values are guide values.

The optimum data for the respective machining task should be determined during the test or machining.



MILLING CUTTERS WITH INDEXABLE INSERTS

New milling programme with indexable inserts for the die & mould sector.



PRODUCT OVERVIEW

Milling cutters with indexable inserts

MAPAL is proud to present a new range of milling cutters with indexable inserts under the product name NeoMill. This range includes round-insert milling cutters, high-feed and 90° shoulder milling cutters, ball and corner radius milling cutter as well as finishing milling cutters for machining cast iron, steel, stainless steel, non-ferrous material and hardened materials up to 65 HRC.

Different systems, cutting materials and coatings are used depending on requirements and the material to be machined.



Ball and corner radius milling cutter



Pre-finishing and finishing of 3D contours

- Universal milling system to ensure maximum productivity
- A tool body with ball and corner radius cutting indexable inserts for pre-finishing and finishing
- Special tool body for ball and corner radius cutting indexable inserts with the highest precision and process reliability requirements
- Highly accurate rotational tolerances
- Perfect surfaces thanks to low-vibration solid carbide tools
- Increased process reliability guaranteed by using ultrafine grain carbides
- Available as shank and screw-in milling cutters

Ø area: 8.00 - 32.00 mm

P H

Round-insert milling cutter



Roughing and pre-finishing of 3D contours

- Perfect for roughing and pre-finishing
- Cutting materials and chip guiding stages are available for soft machining as well as hard/finish machining
- High-precision contours due to the indexable inserts being installed in a neutral position
- Soft cutting behaviour for low vibration machining
- Chip discharge protection
- Available as shell type, shank and screw-in milling cutters

Ø area: 10.00 - 160.00 mm

P M K H



High-feed and 90° shoulder milling cutters

Finishing milling cutter

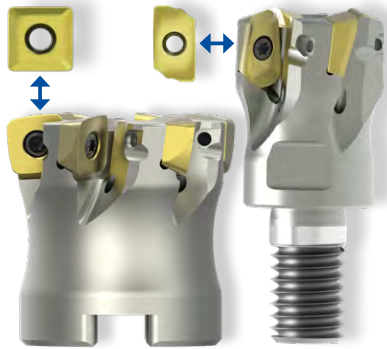

Milling at high feed rates

- Universal tool system to ensure maximum productivity
- Tool body with indexable inserts for high-feed and shoulder milling
- Maximum rate of removal due to very high feed rates and large cutting depths
- Tool and storage costs are reduced
- Double-edged and four-edged indexable inserts available
- Offered as shell type, shank and screw-in milling cutters

Finishing of 90° surfaces, face surfaces and contours

- Axial and radial indexable wiper inserts available to provide an excellent surface finish
- Vibration-free machining for long projections
- Available as screw-in milling cutters

∅ area: 10.00 - 200.00 mm

∅ area: 16.00 - 42.00 mm







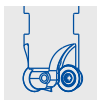

P M K N H

H

SELECTING A MILLING CUTTER

Step-by-step guide to selecting the right milling cutter

Say you're looking for a round-insert milling cutter for roughing steel with a diameter of 32 mm and a radius of 5 mm. This selection guide explains how to choose the perfect tool body and the right indexable insert step by step.

1	Application	Select the type of milling cutter you need.		Ball and corner radius milling cutter		Round-insert milling cutter
2	Blade form	Select the indexable insert shape you need.		Ball indexable insert		Corner radius cutting indexable inserts
3	Material suitability	Select your workpiece according to the MAPAL machining groups (MMG). You'll find the MMG chart on the fold-out page at the end of the catalogue.		Steel		Stainless steel
4	Geometric features	Check that the geometric features meet your requirements.		Radius		Insert size
5	Tool body	Select the milling cutter you need.				
6.1	Indexable insert	Select the indexable insert you need.				
6.2	Cutting material and chip guiding stage	Select the cutting material and chip guiding stage you need. Please take note of the designs on page 246 for this. The name of the indexable insert is supplemented with the selected chip guiding stage and the cutting material type. Example: RDKW1003M0N-PMU-HP635				

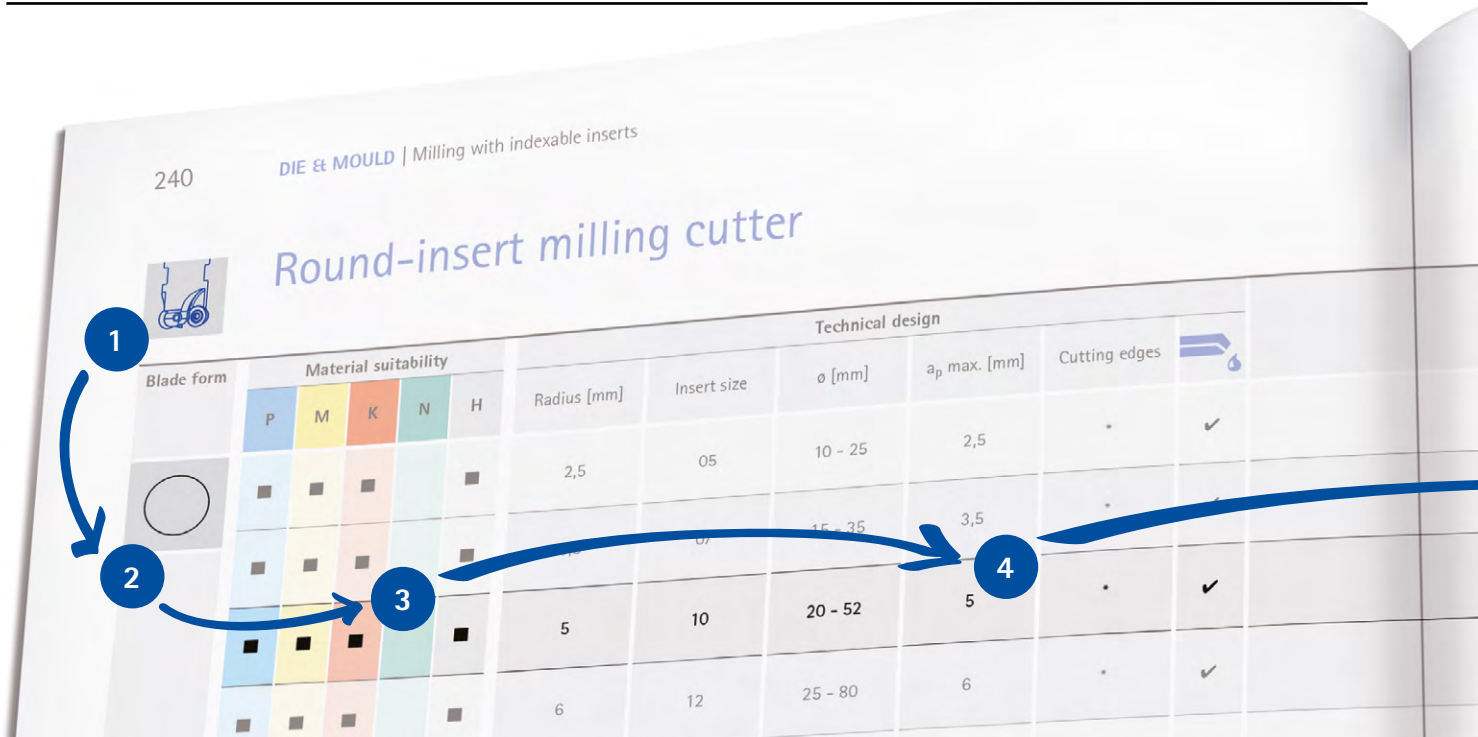



High-feed and 90° shoulder milling cutter



Finishing milling cutter

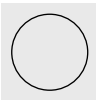

Round insert



90° L-insert 90° machining

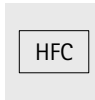

HFC L-insert high-feed machining

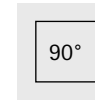

90° S-insert 90° machining



HFC S-insert high-feed machining

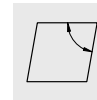

C-insert



Cast iron



Non-ferrous metals



H Hardened steel and cast steel

Diameter range

Max. cutting depth

Number of cutting edges

Coolant supply

Workpiece material	P Unalloyed ← Alloyed → Wear-resistant Toughened	
Coating	PVD	
Cutting material type	HP635	HP640
Cutting edge design	PMU	PMU
RDKW	a_p max. [mm]	
RDKW0501M0N-	1.2 *	31144308
RDKW0702M0N-	1.7 *	31144318
RDKW1003M0N-	2.5 *	31144329
RDKW12T3M0N-	3 *	31144338
RDKW1604M0N-	4 *	31144347

Step 1: Application



Description	Milling cutter			Page	Indexable insert	
	Milling cutter	End milling cutter	Screw-in milling cutter		Description	Page
NeoMill-ISO-360 Insert size 05				266	RD_05	
NeoMill-ISO-360 Insert size 07				268	RD_07	
NeoMill-ISO-360 Insert size 10				274	RD_10	280
NeoMill-ISO-360 Insert size 12				272	RD_12	
NeoMill-ISO-360						



5

6.1

6.2



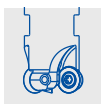

Ball and corner radius milling cutter

Blade form	Material suitability					Technical design					
	P	M	K	N	H	Radius [mm]	Insert size	ø [mm]	a _p max. [mm]	Cutting edges	
	■	■	■	■	■	4 - 12,5	08 - 25	8 - 25	0,55	1	✓
	■	■	■	■	■	4 - 12,5	08 - 25	8 - 25	0,55	1	
	■	■	■	■	■	4 - 12,5	08 - 25	8 - 25	0,55	1	✓
	■	■	■	■	■	4 - 16	08 - 32	8 - 32	0,64	1	✓
	■	■	■	■	■	0,5 - 5	08 - 25	8 - 25	6	1	✓
	■	■	■	■	■	0,5 - 5	08 - 25	8 - 25	6	1	✓



Round-insert milling cutter

Blade form	Material suitability					Technical design					
	P	M	K	N	H	Radius [mm]	Insert size	ø [mm]	a _p max. [mm]	Cutting edges	
	■	■	■	■	■	2,5	05	10 - 25	2,5	*	✓
	■	■	■	■	■	3,5	07	15 - 35	3,5	*	✓
	■	■	■	■	■	5	10	20 - 52	5	*	✓
	■	■	■	■	■	6	12	25 - 80	6	*	✓
	■	■	■	■	■	8	16	32 - 160	8	*	✓

■ highly suitable

■ suitable in some situations

* depending on a_p max.

Step 1:
Application



Step 2:
Blade form



Step 3:
Material suitability



Step 4:
Design









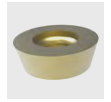











Step 5:
Tool body



Step 6:
Indexable insert

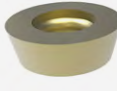

	Milling cutter				Page	Indexable insert		
	Description	Design				Description		Page
		Milling cutter	End milling cutter	Screw-in milling cutter				
	NeoMill-3D-Ballnose Cylindrical							
	NeoMill-3D-Ballnose Conical				BM__08 BM__10 BM__12 BM__16 BM__20 BM__25			264
	NeoMill-3D-Ballnose Solid carbide design							
	NeoMill-3D-Ballnose Cylindrical				261	BM__08, BM__10 BM__12, BM__16 BM__20, BM__25 BM__32		
	NeoMill-3D-Torus Solid carbide design				262	TM__08 TM__10 TM__12 TM__16 TM__20 TM__25		
	NeoMill-3D-Torus Cylindrical				263			266

	Milling cutter				Page	Indexable insert		
	Description	Design				Description		Page
		Milling cutter	End milling cutter	Screw-in milling cutter				
	NeoMill-ISO-360 Insert size 05				270	RD__05		
	NeoMill-ISO-360 Insert size 07				272	RD__07		
	NeoMill-ISO-360 Insert size 10				274	RD__10		280
	NeoMill-ISO-360 Insert size 12				276	RD__12		
	NeoMill-ISO-360 Insert size 16				278	RD__16		



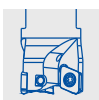

High-feed and 90° shoulder milling cutter

Blade form	Material suitability					Technical design					
	P	M	K	N	H	Radius [mm]	Insert size	ø [mm]	a _p max. [mm]	Cutting edges	
90°	■	■				0,4	06	10 - 50	5,2	2	✓
	■	■	■	■		0,4 - 3	10	16 - 80	9	2	✓
	■	■	■	■		0,8 - 1,6	18	25 - 160	17	2	✓
HFC	■	■			■	1	06	10 - 50	0,7	2	✓
	■	■	■			1,5	10	16 - 80	1,4	2	✓
90°	■	■	■	■		0,4 - 0,8	10	25 - 80	9	4	✓
	■	■	■	■		0,8 - 1,2	14	50 - 125	12	4	✓
HFC	■	■			■	1,2	06	16 - 35	1	4	✓
	■	■	■		■	1,5	10	25 - 80	1,5	4	✓
	■	■	■		■	2	14	50 - 125	2,4	4	✓
	■	■	■		■	3	18	80 - 200	3,5	4	✓



Finishing milling cutter

Blade form	Material suitability					Technical design					
	P	M	K	N	H	Radius [mm]	Insert size	ø [mm]	a _p max. [mm]	Cutting edges	
					■	1	06	16 - 42	6	2	✓

■ highly suitable

□ suitable in some situations

Step 1:
Application



Step 2:
Blade form



Step 3:
Material suitability



Step 4:
Design



Step 5:
Tool body





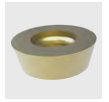

Step 6:
Indexable insert



	Milling cutter				Page	Indexable insert		
	Description	Design				Description		Page
		Milling cutter	End milling cutter	Screw-in milling cutter				
	NeoMill-2-HiFeed90 Insert size 06				286	LPMX06		298
	NeoMill-2-HiFeed90 Insert size 10				288	LD_X10		298
	NeoMill-2-HiFeed90 Insert size 18				290	LD_X18		
	NeoMill-2-HiFeed90 Insert size 06				286	LPMX06		296
	NeoMill-2-HiFeed90 Insert size 10				288	LD_X10		296
	NeoMill-4-HiFeed90 Insert size 10				294	SD_T10		302
	NeoMill-4-HiFeed90 Insert size 14				296	SD_T14		
	NeoMill-4-HiFeed90 Insert size 06				292	SDM_06		304
	NeoMill-4-HiFeed90 Insert size 10				294	SDM_10		
	NeoMill-4-HiFeed90 Insert size 14				296	SDM_14		
	NeoMill-4-HiFeed90 Insert size 18				297	SDM_18		

	Milling cutter				Page	Indexable insert		
	Description	Design				Description		Page
		Milling cutter	End milling cutter	Screw-in milling cutter				
	NeoMill-3D-Finish				310	CDGX06		311

Product overview for indexable inserts

Insert type	Radial technology			
	BM..	TM..	RDKW..	RDKT..
				

Features

Number of cutting edges	1	1	*	*
Insert size	8 - 32	8 - 25	5 - 16	12 - 16
Cutting direction	R	R	neutral	neutral
Radius	4 - 16	0.5 - 5	2.5 - 8	6 - 8

Application

Finishing F	■			
Pre-finishing S	■	■		
Medium machining M	■	■	■	■
Roughing R			■	

Material suitability

P			■	■
M			■	■
K			■	
N				
H	■	■	■	
Page	264	266	280	280

* depending on a_p max.

Insert type	Radial technology			
	LDMX..		LDHX..	SDHT..
				
	90°	HFC	90°	90°

Features





Number of cutting edges	2	2	2	4
Insert size	10 - 18	10	10	10 - 14
Cutting direction	R	R	R	R
Radius	0.4 - 1.6	1.5	0.4 - 0.8	0.4 - 1.2

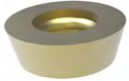

Application

Finishing F				
Pre-finishing S				
Medium machining M	■	■	■	■
Roughing R	■			

Material suitability

P	■	■		
M	■	■		
K	■	■		
N			■	■
H		■		
Page	298	300	298	302

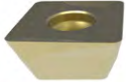
Radial technology				
RDHW..	RDHT..	LPMX..		LDGX..
		 90°	 HFC	 90°
*	*	2	2	2
5 - 16	12	6	6	18
neutral	neutral	R	R	R
2.5 - 8	6	0.4	1	0.8
■				
■	■	■	■	■
■				
		■	■	
	■	■	■	
				■
■			■	
280	280	298	300	298

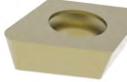
Radial technology				
SDMT..	SDMW..	CDGX..		
 90°	 HFC	 HFC		
4	4	4	2	
10 - 14	06 - 18	10 - 18	6	
R	R	R	R	
0.8 - 1.2	1.2 - 3	1.5 - 3	1	
			■	
■	■			
		■		
■	■	■	■	
■	■	■	■	
	■	■	■	
302	304	304	311	

Cutting materials overview: Selecting the right cutting material

The cutting materials cover a wide spectrum of wear resistance and ductility. The designation of the cutting material indicates the level of ductility; the ductility increases as the number increases.

PVD-coated cutting materials (HP..) are the top choice when it comes to milling K, P and M workpiece materials. These cutting materials have the longest tool life.

Example:

HP645 is more ductile than HP630 (the more ductile the cutting material, the less resistant it is to wear).

1. Select your workpiece material according to the MMG (MAPAL machining groups; see the fold-out page at the end of the catalogue).
2. From the **"Cutting materials overview"** table, choose the grade underneath the required workpiece material.
3. Depending on the general conditions (see the adjacent table **"General conditions"**), a more wear-resistant or more ductile PVD-coated cutting material is to be selected.

General conditions

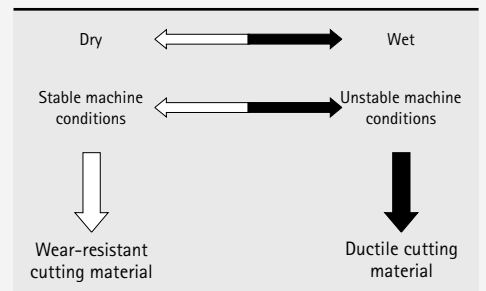

Selecting the right chip guiding stage

If several chip guiding stages are available for one cutting material, the manufacturing processes and type of machining determine which option is most suitable. The chip guiding stage is identified by a three-letter code.

This is made up of the workpiece material (1st letter), manufacturing processes (2nd letter) and type of machining (3rd letter). The individual characteristics are shown in the tables in this section.

Example:

HFF is a chip guiding stage for finishing hardened steel with fine geometry for gentle soft cutting.

1st letter: Workpiece material

Code letter	Design
P	Steel
M	Stainless steel
K	Cast iron
N	Non-ferrous metal
H	Hardened steel

Cutting materials overview

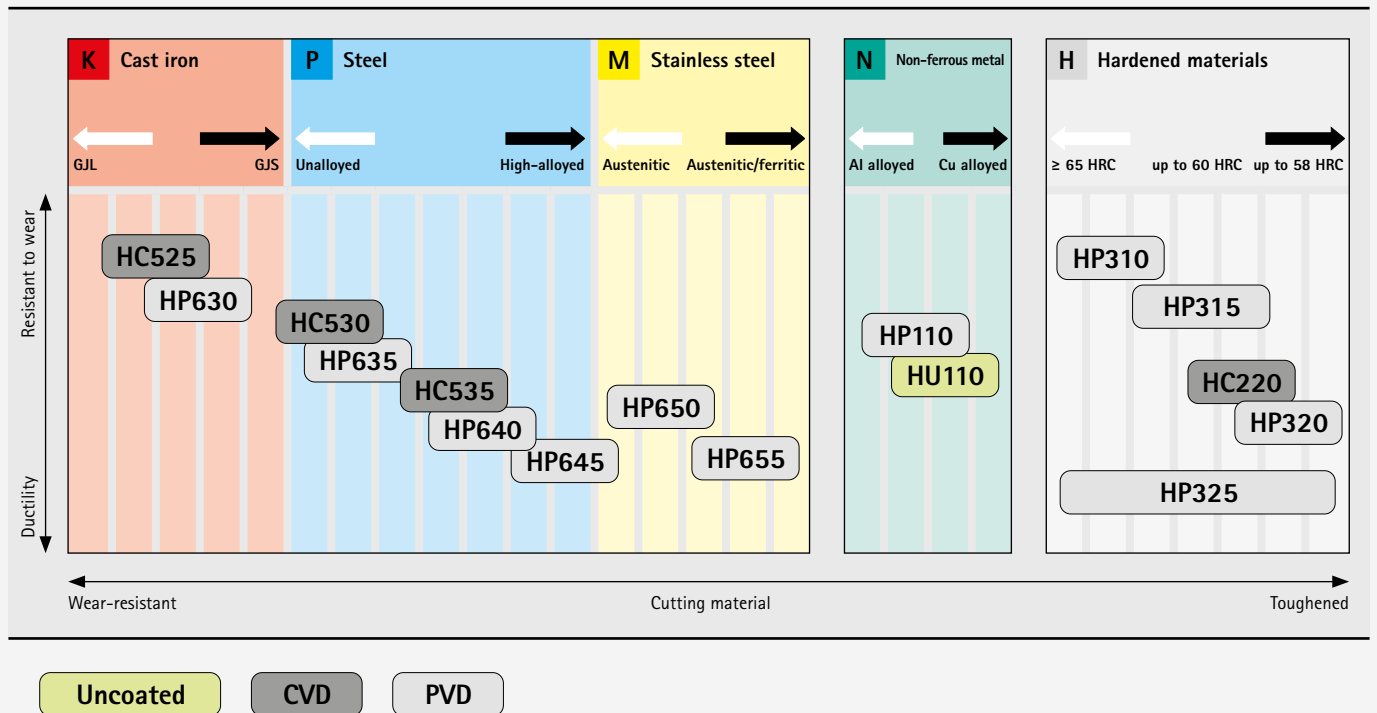

2nd letter: Manufacturing processes

Code letter	Design
F	Finishing
S	Pre-finishing
M	Medium machining
R	Roughing

3rd letter: Type of machining

Code letter	Design
F	Fine
W	Wiper
U	Universal
S	Speed
1	Neutral 1
2	Neutral 2

Cutting materials overview:

Types and type description

Cutting material	Name of cutting material	Coating composition	Colour of coating	Field of application	Recommended application
Carbide PVD-coated	HP110	AlTiN	Dark grey	●	TiAlN-coated carbide for machining aluminium materials and other non-ferrous metals. Due to the very thin layer, the cutting material is also well suited for finishing stainless steels and grey cast iron.
	HP310	TiSiN	Reddish-brown	●	Finest grain-carbide grade with high wear resistance and temperature stable PVD coating. Suitable for the finishing of steel materials in the area of the highest cutting speeds.
	HP315	TiSiN	Reddish-brown	●	Finest grain-carbide grade with wear-resistant PVD coating. Suitable for the finishing of steel materials up to max. 60 HRC.
	HP320	AlTiN	Light grey	●	Universal ultra-fine grain-carbide grade, which is highly resistant to wear and has good breakage resistance and edge stability. Suitable for the machining of hard steel materials up to max. 60 HRC thanks to the temperature resistant PVD coating.
	HP325	AlTiN	Light grey	✚	Finest grain-carbide grade with a balanced ratio between ductility and resistance to wear. Wide field of applications for steel materials due to the stress-optimised PVD coating.
	HP630	AlTiN	Dark grey	●	Ductile carbide grade with an AlTiN coating. Suitable for the machining of cast iron materials. Also suitable for the finishing of steel materials and cold-work steels with a hardening agent greater than 54 HRC.
	HP635	AlTiN-TiN	gold	●	Carbide grade with PVD coating. Suitable for milling unalloyed, low-alloyed, high-alloyed and stainless steels. Particularly suitable for high cutting speeds in both dry and wet machining under stable conditions.
	HP640	AlTiN-TiN	gold	●	Universal carbide grade with high ductility and an AlTiN-TiN coating. Suitable for the machining of steel materials. Particularly suitable for dry milling at low to medium cutting speeds under difficult conditions.
	HP645	AlTiN-TiN	gold	✚	Ductile carbide grade with a PVD coating. Suitable in the event that the cutting of steel materials such as tool steels, heat-treated steel, case hardening steels and austenitic stainless materials is sharply interrupted.
	HP650	AlTiN	Dark grey	●	Finest grain-carbide grade with a wear-resistant AlTiN coating. Suitable for the machining of stainless and austenitic stainless materials. Suitable for both wet and dry machining.
	HP655	AlTiN	Dark grey	●	Fine grain-carbide grade with extreme ductility. A thin, smooth PVD coating is ideal for the milling of austenitic stainless steels and duplex group workpiece materials at low to medium cutting speeds.
Carbide CVD-coated	HC220	AlTiN	Black anthracite	●	Wear-resistant finest grain-carbide grade for a wide range of applications. Suitable for steel materials under stable conditions. New CVD coating with high temperature hardness, which is resistant to wear and tear.
	HC525	AlTiN	Black anthracite	●	Optimised carbide substrate with an extremely hard and wear-resistant CVD multilayer coating. Ideally suited for dry machining of grey cast iron (GJL), spheroidal graphite cast iron (GJS), malleable cast iron and alloyed cast iron.
	HC530	AlTiN	Black anthracite	●	Harder alternative to HP635 with a CVD coating that is highly resistant to abrasive wear and tear. Excellent for the face milling of steel materials with increased cutting speed under stable conditions.
	HC535	AlTiN	black anthracite	●	This ductile carbide grade with a modern CVD coating offers economical dry machining at high cutting speeds. Particularly suitable for face milling for a wide range of steel materials.
Uncoated	HU110	-	-	●	Uncoated carbide grade for the machining of aluminium and other non-ferrous metals.

Product ID codes

Milling cutters with indexable inserts

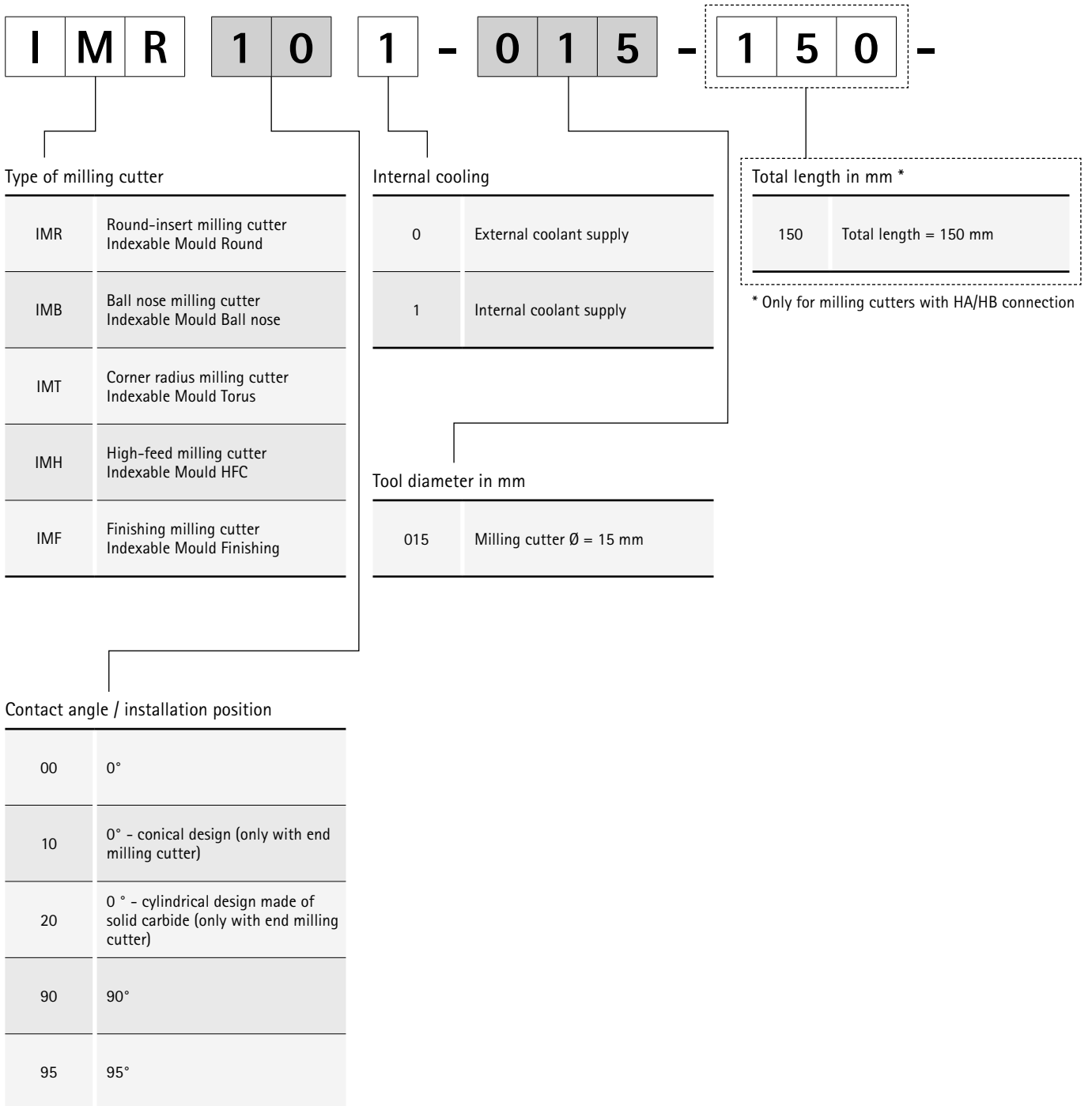

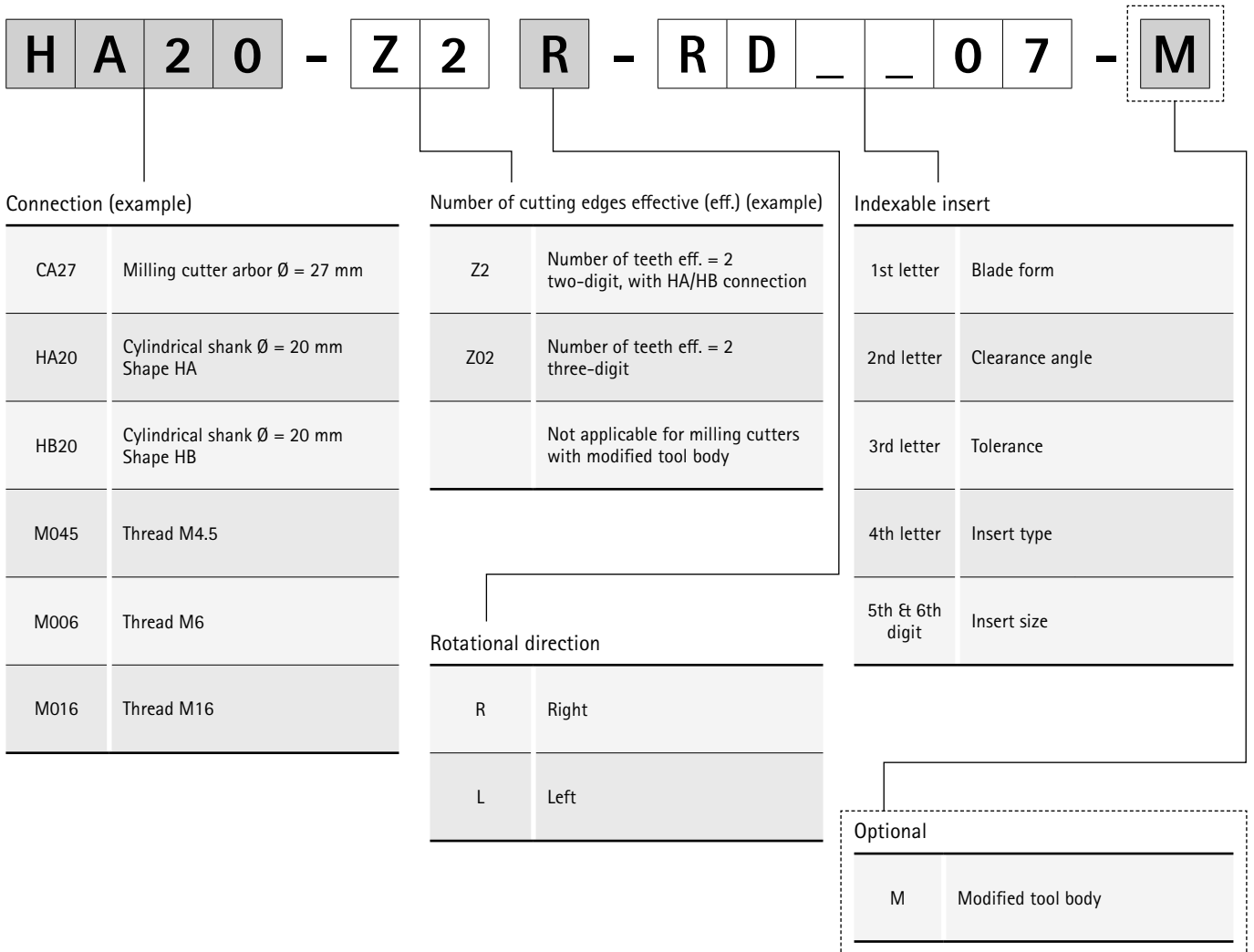

Product ID codes

Radial indexable inserts

L
P
M
X
06
02
10

Blade form

C (80°)



L (90°)



R



S (90°)





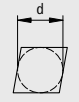
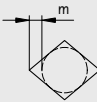
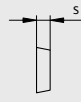

Tolerance

			
	d [mm]	m [mm]	s [mm]
G	±0,025	±0,025	±0,13
H	±0,013	±0,013	±0,025
K	from ±0.05 to ±0.15*	±0,013	±0,025
M	from ±0.05 to ±0.15*	from ±0.08 to ±0.20*	±0,13

* Tolerance depends on the insert size

Insert size

Incircle	d [mm]			
				
05			5	
06	6,5	3,64		6,75*
07			7	
10		6,6	10	10,2*/10,4
12			12	
14				14,7*/14,8
16			16	
18		9,65		18,7*

* High-feed machining

Clearance angle

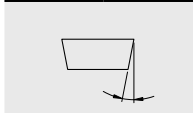
	D	15°
	P	11°

Insert type

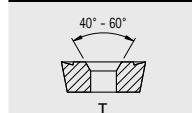

T

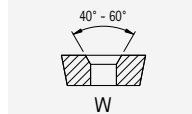





W

Special shape (see diagram)

X

Insert thickness

Identification number	s [mm]			
				
01			1,5	
02	2,38	2,15	2,38	2,5*
03			3,18	
T3			3,97	
04		4,76	4,76	4,86
05		5		5*/5,2
06				6*

* High-feed machining

Corner radius

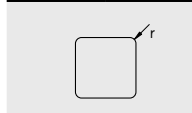
Identification number	r [mm]
	
04	0,4
08	0,8
10	1,0
12	1,2
15	1,5
16	1,6
20	2,0
30	3,0
MO	Round insert

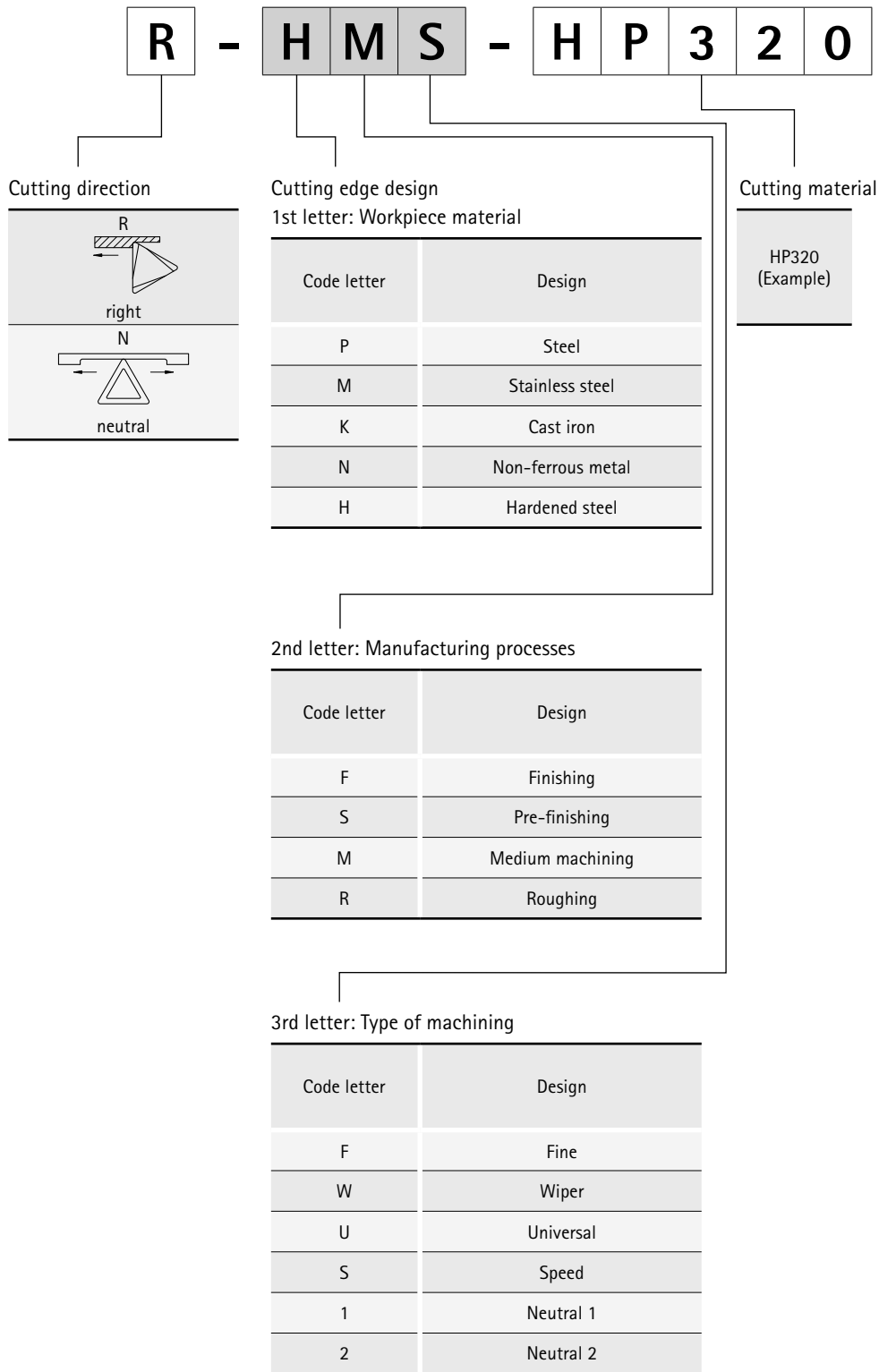

Product ID codes

Ball and corner radius cutting indexable inserts

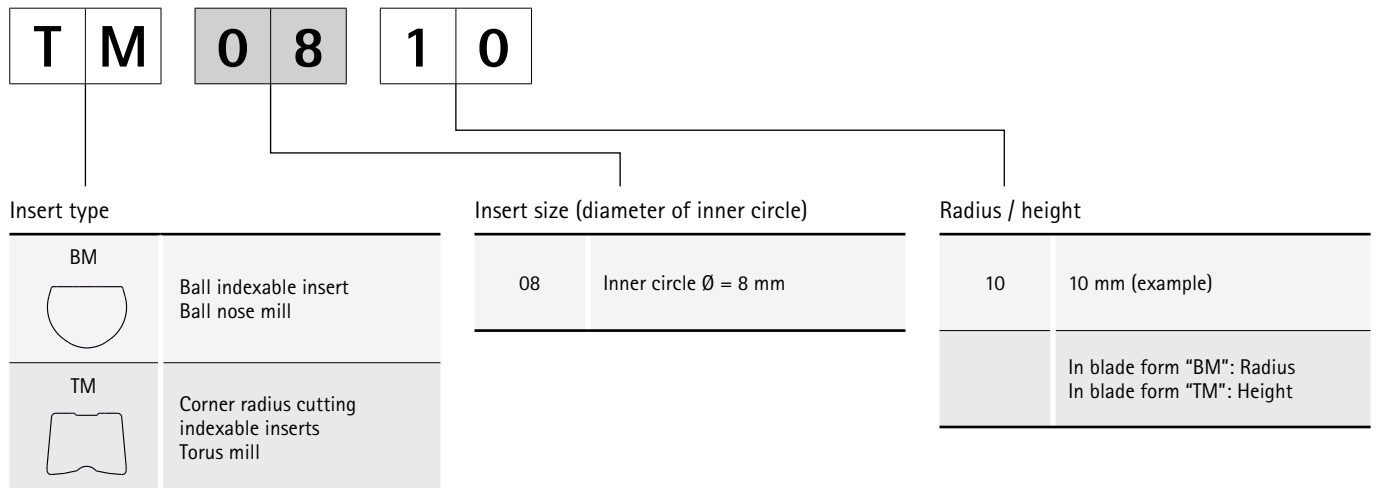

R - **H M 1** - **H P 3 2 0**

Cutting direction

R	Right
L	Left

Cutting edge design

1st letter	Workpiece material
2nd letter	Manufacturing processes
3rd letter	Type of machining
	For characteristics see product ID code for radial indexable inserts

Cutting material

HP320 (example)



BALL AND CORNER RADIUS MILLING CUTTER

NeoMill-3D-Ballnose

End milling cutter, cylindrical design	258
End milling cutter, conical design	259
End milling cutter, cylindrical design with solid carbide shank	260
Screw-in milling cutter	261

NeoMill-3D-Torus

End milling cutter	262
Screw-in milling cutter	263

Ball and corner radius cutting indexable inserts

BM, ball indexable insert	264
TM, corner radius cutting indexable insert	266

Accessories and spare parts

Spare part for radial indexable inserts	313
---	-----

Technical appendix

Cutting data recommendations	267
------------------------------------	-----

NeoMill®-3D-Ballnose

Ball and corner radius milling cutter

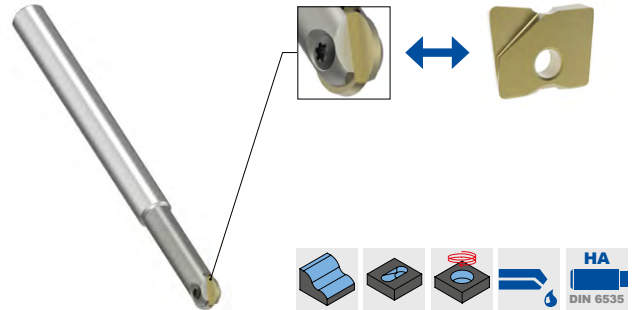
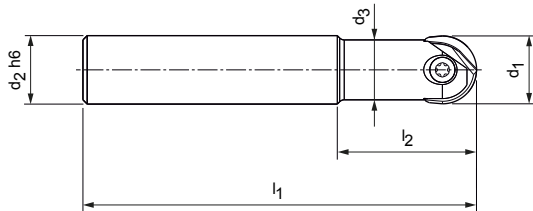

End milling cutter, cylindrical design

Dimensions					Z _{eff}	Weight [kg]	Internal cooling	Specification	Order no.
d ₁	d ₂ h6	d ₃	l ₁	l ₂					
8	12	7	92	32	2	0,06	✓	IMB001-008-092-HA12-Z2R-BM__08	31144119
10	12	8,8	92	32	2	0,08	✓	IMB001-010-092-HA12-Z2R-BM__10	31144120
12	12	10,8	92	32	2	0,08	✓	IMB001-012-092-HA12-Z2R-BM__12	31144121
12	12	10	145	45,5	2	0,11	–	IMB000-012-145-HA12-Z2R-BM__12	31144122
16	16	14,5	92	32	2	0,21	✓	IMB001-016-092-HA16-Z2R-BM__16	31144123
16	16	14	160	55,5	2	0,22	–	IMB000-016-160-HA16-Z2R-BM__16	31144124
20	20	17,5	104	38	2	0,2	✓	IMB001-020-104-HA20-Z2R-BM__20	31144125
20	20	17	190	65,5	2	0,4	–	IMB000-020-190-HA20-Z2R-BM__20	31144126
25	25	22,5	121	45	2	0,46	✓	IMB001-025-121-HA25-Z2R-BM__25	31144127
25	25	21	210	75,5	2	0,69	–	IMB000-025-210-HA25-Z2R-BM__25	31144128

Accessories

	Ball indexable insert	Page 264
	Corner radius cutting indexable inserts	Page 266
	Chucks	Page 446

Spare parts*

	Clamping screw for indexable insert		Order no.
	BM/TM__	Specification	
	BM/TM__08	M2.5X6.25-TX7-IP	31161844
	BM/TM__10	M3X7.7-TX8-IP	31161845
	BM/TM__12	M3.5X9.5-TX10-IP	31161846
	BM/TM__16	M4X13.3-TX15-IP	31161847
	BM/TM__20	M5X16.2-TX20-IP	31161848
	BM/TM__25	M6X20-TX25-IP	31161849

Dimensions in mm.

The maximum operating speeds refer only to the cutting edge system.

* Included in scope of delivery.

Depending on the clamping device used, different maximum operating speeds must be observed.

NeoMill®-3D-Ballnose

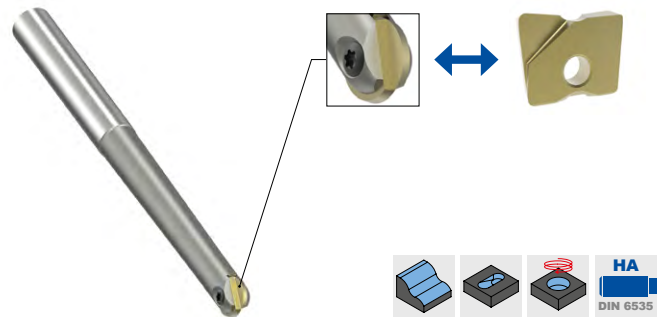
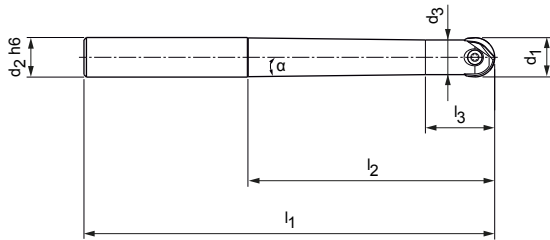

Ball and corner radius milling cutter



End milling cutter, conical design

Dimensions							Z _{eff}	Weight [kg]	Internal cooling	Specification	Order no.
d ₁	d ₂ h6	d ₃	l ₁	l ₂	l ₃	α					
8	12	6,5	110	53	18,5	3°30'	2	0,07	–	IMB100-008-110-HA12-Z2R-BM__08	31144107
8	12	6,5	132	75	18,5	2°	2	0,08	–	IMB100-008-132-HA12-Z2R-BM__08	31144108
10	12	8,5	110	53	21	2°20'	2	0,07	–	IMB100-010-110-HA12-Z2R-BM__10	31144109
10	12	8	132	75	21	1°15'	2	0,08	–	IMB100-010-132-HA12-Z2R-BM__10	31144110
12	12	10	110	53	22	1°20'	2	0,08	–	IMB100-012-110-HA12-Z2R-BM__12	31144111
12	12	10	145	85	22	0°40'	2	0,11	–	IMB100-012-145-HA12-Z2R-BM__12	31144112
16	16	14	123	63	28	1°15'	2	0,16	–	IMB100-016-123-HA16-Z2R-BM__16	31144113
16	16	14	166	100	28	0°40'	2	0,22	–	IMB100-016-166-HA16-Z2R-BM__16	31144114
20	20	17	141	75	34	2°	2	0,3	–	IMB100-020-141-HA20-Z2R-BM__20	31144115
20	20	17	191	115	34	1°	2	0,39	–	IMB100-020-191-HA20-Z2R-BM__20	31144116
25	25	21	166	90	41	2°	2	0,52	–	IMB100-025-166-HA25-Z2R-BM__25	31144117
25	32	21	215	135	41	3°	2	0,97	–	IMB100-025-215-HA32-Z2R-BM__25	31144118

Accessories

		Ball indexable insert	Page 264
		Corner radius cutting indexable inserts	Page 266
		Chucks	Page 446

Spare parts*

		Clamping screw for indexable insert	Order no.
	BM/TM__08	M2.5X6.25-TX7-IP	31161844
	BM/TM__10	M3X7.7-TX8-IP	31161845
	BM/TM__12	M3.5X9.5-TX10-IP	31161846
	BM/TM__16	M4X13.3-TX15-IP	31161847
	BM/TM__20	M5X16.2-TX20-IP	31161848
	BM/TM__25	M6X20-TX25-IP	31161849

Dimensions in mm.

The maximum operating speeds refer only to the cutting edge system.

* Included in scope of delivery.

Depending on the clamping device used, different maximum operating speeds must be observed.

NeoMill®-3D-Ballnose

Ball and corner radius milling cutter

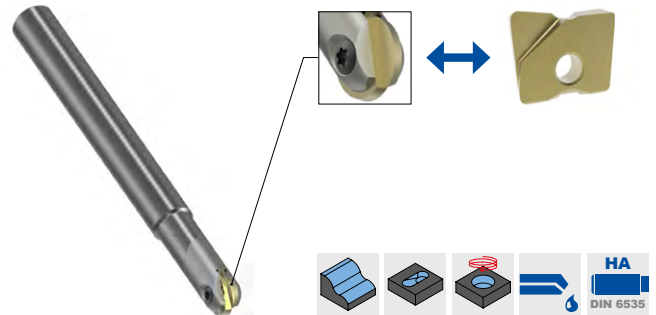
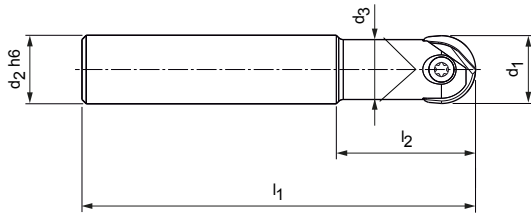

End milling cutter, cylindrical design with solid carbide shank

Dimensions					Z _{eff}	Weight [kg]	Internal cooling	Specification	Order no.
d ₁	d ₂ h6	d ₃	l ₁	l ₂					
8	8	7	80	25	2	0,05	✓	IMB201-008-080-HA08-Z2R-BM__08	31144129
8	8	7	100	25	2	0,06	✓	IMB201-008-100-HA08-Z2R-BM__08	31144130
10	10	8,8	120	35	2	0,12	✓	IMB201-010-120-HA10-Z2R-BM__10	31144133
10	10	8,8	150	50	2	0,14	✓	IMB201-010-150-HA10-Z2R-BM__10	31144134
12	12	10,5	80	35	2	0,1	✓	IMB201-012-080-HA12-Z2R-BM__12	31144135
12	12	10,5	120	35	2	0,16	✓	IMB201-012-120-HA12-Z2R-BM__12	31144136
12	12	10,5	160	50	2	0,22	✓	IMB201-012-160-HA12-Z2R-BM__12	31144137
16	16	14	100	40	2	0,23	✓	IMB201-016-100-HA16-Z2R-BM__16	31144138
16	16	14	140	40	2	0,34	✓	IMB201-016-140-HA16-Z2R-BM__16	31144139
16	16	14	175	55	2	0,43	✓	IMB201-016-175-HA16-Z2R-BM__16	31144140
20	20	18	140	50	2	0,52	✓	IMB201-020-140-HA20-Z2R-BM__20	31144142
20	20	18	190	75	2	0,72	✓	IMB201-020-190-HA20-Z2R-BM__20	31144143
25	25	22,4	210	90	2	1,21	✓	IMB201-025-210-HA25-Z2R-BM__25	31144145

Accessories

	Ball indexable insert	Page 264
	Corner radius cutting indexable inserts	Page 266
	Chucks	Page 446

Spare parts*

	Clamping screw for indexable insert	Order no.	
	BM/TM__08	M2.5X6.25-TX7-IP	31161844
	BM/TM__10	M3X7.7-TX8-IP	31161845
	BM/TM__12	M3.5X9.5-TX10-IP	31161846
	BM/TM__16	M4X13.3-TX15-IP	31161847
	BM/TM__20	M5X16.2-TX20-IP	31161848
	BM/TM__25	M6X20-TX25-IP	31161849

Dimensions in mm.

The maximum operating speeds refer only to the cutting edge system.

* Included in scope of delivery.

Depending on the clamping device used, different maximum operating speeds must be observed.

NeoMill®-3D-Ballnose

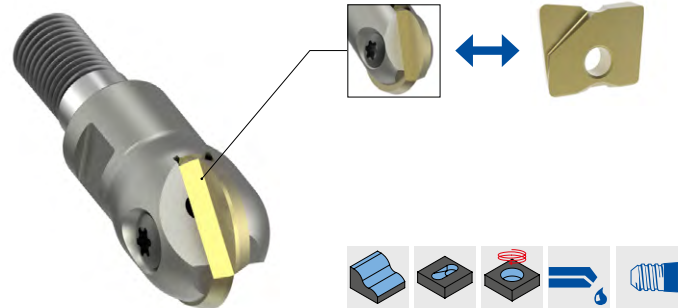
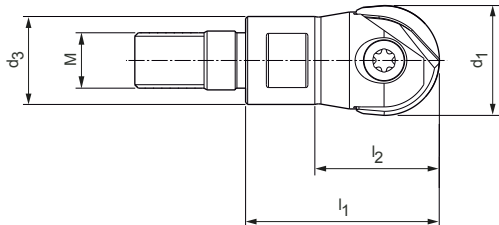

Ball and corner radius milling cutter



Screw-in milling cutter

Dimensions					Z _{eff}	SW	Weight [kg]	Internal cooling	Specification	Order no.
d ₁	M	d ₃	l ₁	l ₂						
8	6	9,7	23	17	2	8	0,01	✓	IMB001-008-M006-Z02R-BM__08	31144210
10	6	9,7	23	16,5	2	8	0,01	✓	IMB001-010-M006-Z02R-BM__10	31144211
12	6	9,7	23	14	2	8	0,01	✓	IMB001-012-M006-Z02R-BM__12	31144212
12	8	12,7	28	21,2	2	10	0,02	✓	IMB001-012-M008-Z02R-BM__12	31144213
16	8	12,7	28	18	2	10	0,02	✓	IMB001-016-M008-Z02R-BM__16	31144214
16	10	15,4	28	17	2	12	0,04	✓	IMB001-016-M010-Z02R-BM__16	31144215
20	10	17,7	28	15	2	12	0,04	✓	IMB001-020-M010-Z02R-BM__20	31144216
25	12	20,7	35	25	2	17	0,08	✓	IMB001-025-M012-Z02R-BM__25	31144217
32	16	28,7	43	28	2	24	0,15	✓	IMB001-032-M016-Z02R-BM__32	31144218

Accessories

	d ₁ 8 - 32	Ball indexable insert	Page 264
	d ₁ 8 - 25	Corner radius cutting indexable inserts	Page 266
		MFS milling head holder	Page 446

Spare parts*

		Clamping screw for indexable insert	Order no.
	BM/TM__08	M2.5X6.25-TX7-IP	31161844
	BM/TM__10	M3X7.7-TX8-IP	31161845
	BM/TM__12	M3.5X9.5-TX10-IP	31161846
	BM/TM__16	M4X13.3-TX15-IP	31161847
	BM/TM__20	M5X16.2-TX20-IP	31161848
	BM/TM__25	M6X20-TX25-IP	31161849
	BM__32	M8X25-TX40-IP	31161850

Dimensions in mm.

The maximum operating speeds refer only to the cutting edge system.

* Included in scope of delivery.

Depending on the clamping device used, different maximum operating speeds must be observed.

NeoMill®-3D-Torus

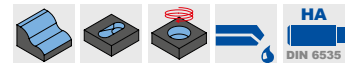
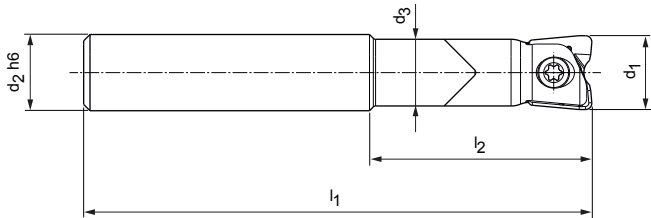

Corner radius milling cutter



End milling cutter, cylindrical design with solid carbide shank

Dimensions					z _{eff}	Weight [kg]	Internal cooling	Specification	Order no.
d ₁	d ₂ h6	d ₃	l ₁	l ₂					
8	8	7	80	25	2	0,05	✓	IMT201-008-080-HA08-Z2R-TM__08	31146612
8	8	7	100	25	2	0,06	✓	IMT201-008-100-HA08-Z2R-TM__08	31146613
10	10	8,8	120	35	2	0,11	✓	IMT201-010-120-HA10-Z2R-TM__10	31146616
10	10	8,8	150	50	2	0,14	✓	IMT201-010-150-HA10-Z2R-TM__10	31146617
12	12	10,5	80	35	2	0,1	✓	IMT201-012-080-HA12-Z2R-TM__12	31146618
12	12	10,5	120	35	2	0,16	✓	IMT201-012-120-HA12-Z2R-TM__12	31146619
12	12	10,5	160	50	2	0,22	✓	IMT201-012-160-HA12-Z2R-TM__12	31146620
16	16	14	100	40	2	0,23	✓	IMT201-016-100-HA16-Z2R-TM__16	31146621
16	16	14	140	55	2	0,34	✓	IMT201-016-140-HA16-Z2R-TM__16	31146623
16	16	14	175	55	2	0,43	✓	IMT201-016-175-HA16-Z2R-TM__16	31146624
20	20	18	140	50	2	0,52	✓	IMT201-020-140-HA20-Z2R-TM__20	31146626
20	20	18	190	75	2	0,72	✓	IMT201-020-190-HA20-Z2R-TM__20	31146627
25	25	22,4	210	90	2	1,21	✓	IMT201-025-210-HA25-Z2R-TM__25	31146629

Accessories

	Corner radius cutting indexable inserts	Page 266
	Chucks	Page 446

Spare parts*

		Clamping screw for indexable insert	Order no.
	TM__08	M2.5X6.25-TX7-IP	31161844
	TM__10	M3X7.7-TX8-IP	31161845
	TM__12	M3.5X9.5-TX10-IP	31161846
	TM__16	M4X13.3-TX15-IP	31161847
	TM__20	M5X16.2-TX20-IP	31161848
TM__25	M6X20-TX25-IP	31161849	

Dimensions in mm.

The maximum operating speeds refer only to the cutting edge system.

* Included in scope of delivery.

Depending on the clamping device used, different maximum operating speeds must be observed.

NeoMill®-3D-Torus

Corner radius milling cutter

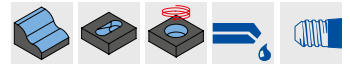
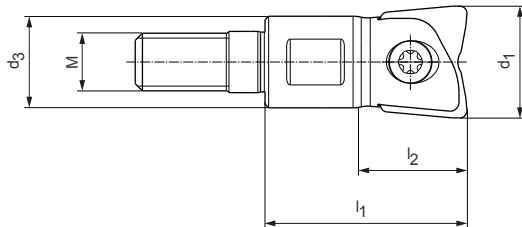

Screw-in milling cutter

Dimensions					Z _{eff}	SW	Weight [kg]	Internal cooling	Specification	Order no.
d ₁	M	d ₃	l ₁	l ₂						
8	4,5	7,7	23	23	2	6	0,01	✓	IMT001-008-M045-Z02R-TM__08	31146604
10	6	9,7	23	23	2	8	0,01	✓	IMT001-010-M006-Z02R-TM__10	31146605
12	6	9,7	23	23	2	8	0,01	✓	IMT001-012-M006-Z02R-TM__12	31146606
12	8	12,7	28	19	2	10	0,02	✓	IMT001-012-M008-Z02R-TM__12	31146607
16	8	12,7	28	28	2	10	0,03	✓	IMT001-016-M008-Z02R-TM__16	31146608
16	10	15,4	28	28	2	12	0,04	✓	IMT001-016-M010-Z02R-TM__16	31146609
20	10	17,7	28	28	2	12	0,05	✓	IMT001-020-M010-Z02R-TM__20	31146610
25	12	20,7	35	35	2	17	0,08	✓	IMT001-025-M012-Z02R-TM__25	31146611

Accessories

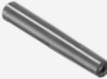
	Corner radius cutting indexable inserts	Page 266
	MFS milling head holder	Page 446

Spare parts*

		Clamping screw for indexable insert	Order no.
	TM__08	M2.5X6.25-TX7-IP	31161844
	TM__10	M3X7.7-TX8-IP	31161845
	TM__12	M3.5X9.5-TX10-IP	31161846
	TM__16	M4X13.3-TX15-IP	31161847
	TM__20	M5X16.2-TX20-IP	31161848
TM__25	M6X20-TX25-IP	31161849	

Dimensions in mm.

The maximum operating speeds refer only to the cutting edge system.

* Included in scope of delivery.

Depending on the clamping device used, different maximum operating speeds must be observed.

BM

Ball indexable insert

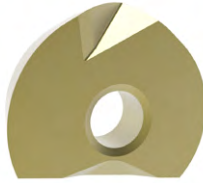

	Carbide			
Workpiece material	H			
	≥ 65 HRC ← Wear-resistant	60 HRC		58 HRC → Toughened
Coating	PVD			
Cutting material type	HP310			
Cutting edge design				
BM08	a_p max. [mm]			
BM0804R-	0.2 *			
BM10				
BM1005R-	0.24 *			
Cutting edge design	HFF	HF2	HS1	
BM12	a_p max. [mm]			
BM1206R-	0.4 *	31144422	31144423	31146669
BM16				
BM1608R-	0.45 *	31144430	31144431	31146671
BM20				
BM2010R-	0.5 *	31144438	31144439	31146675
Cutting edge design				
BM25	a_p max. [mm]			
BM2512R-	0.55 *			
BM32				
BM3216R-	0.64 *			

Feed per tooth (selection according to chip guiding stage) and plunge angle

MMG **	Chip guiding stage	BM_08			BM_10			BM_12												
		a _p max. [mm]			f _z [mm/tooth]			a _p max. [mm]			f _z [mm/tooth]									
P	H	HFF							0.06	0.12	0.18	0.08	0.14	0.2						
		HMF							0.1	0.15	0.24	0.15	0.22	0.3						
		HSF							0.15	0.25	0.3	0.15	0.25	0.3						
		HF2							0.06	0.12	0.18	0.08	0.14	0.2						
		HM1	0.1	0.15	0.2	0.1	0.15	0.2	0.12	0.2	0.24	0.15	0.2	0.25	0.15	0.3	0.4	0.15	0.25	0.35
		HM2	0.1	0.15	0.2	0.1	0.15	0.2	0.12	0.2	0.24	0.15	0.2	0.25	0.15	0.3	0.4	0.15	0.25	0.35
		HS1										0.1	0.16	0.22	0.1	0.16	0.22			
		HS2	0.1	0.12	0.15	0.08	0.12	0.15	0.1	0.15	0.2	0.1	0.15	0.2	0.1	0.16	0.22	0.1	0.16	0.22

* a_p max. depends on the type of milling cutter and application.

** MAPAL machining groups

Carbide									
H									
≥ 65 HRC					60 HRC			58 HRC	
Wear-resistant					Toughened				
PVD									
HP315			HP320			HP325			
HS2	HM1		HM1	HM2		HM1	HM2		
31144418	31146666		31146524	31144416		31146525	31144417		
31144421	31146667		31146526	31144419		31146527	31144420		
HSF	HS2	HM1	HSF	HM1	HM2	HMF	HM1	HM2	
31144428	31144429	31146668	31144427	31146528	31144425	31144424	31146529	31144426	
31144436	31144437	31146670	31144435	31146530	31144433	31144432	31146532	31144434	
31144444	31144445	31146673	31144443	31146672	31144441	31144440	31146674	31144442	
HSF	HS2	HM1	HSF	HM1	HM2	HMF	HM1	HM2	
31144450	31144451	31146676	31144449	31146533	31144447	31144446	31146534	31144448	
31144454	31146664	31146678	31144453	31146677	31146663	31144452	31146679	31146665	

Dimensions [mm]		
d	s	d ₁
8	2,39	2,5
10	2,59	3
12	2,99	3,5
16	3,99	4
20	4,99	5
25	5,99	6
32	6,99	8

BM_16			BM_20			BM_25			BM_32		
a _p max. [mm]			f _z [mm/tooth]			a _p max. [mm]			f _z [mm/tooth]		
0.08	0.15	0.22	0.12	0.18	0.24	0.12	0.2	0.28	0.18	0.24	0.3
0.13	0.2	0.32	0.18	0.25	0.3	0.2	0.25	0.4	0.22	0.3	0.38
0.2	0.3	0.35	0.2	0.3	0.35	0.2	0.35	0.45	0.25	0.4	0.45
0.08	0.15	0.22	0.12	0.18	0.24	0.12	0.2	0.28	0.18	0.24	0.3
0.2	0.35	0.45	0.2	0.3	0.35	0.25	0.4	0.5	0.3	0.45	0.55
0.2	0.35	0.45	0.2	0.3	0.35	0.25	0.4	0.5	0.3	0.45	0.55
0.12	0.18	0.24	0.14	0.2	0.26	0.16	0.24	0.32	0.2	0.28	0.36
0.12	0.18	0.24	0.14	0.2	0.26	0.16	0.24	0.32	0.22	0.3	0.38

TM

Corner radius cutting indexable inserts



	Carbide		
Workpiece material	H		
	≥ 65 HRC ← Wear-resistant	60 HRC	58 HRC → Toughened
Coating	PVD		
Cutting material type	HP320		
Cutting edge design	HM1	HSF	

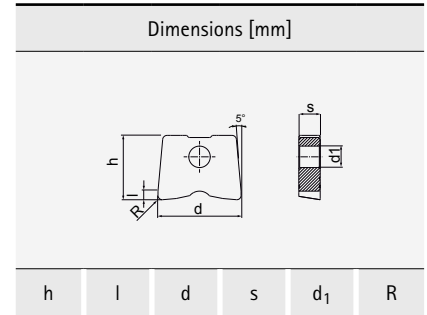

TM08	a_p max. [mm]		
TM0806R-	1.6 *	31144455	
TM0810R-	2 *	31144456	31144457

7	1.6	8	2.4	2.5	0.6
7	2	8	2.4	2.5	1

Cutting edge design	HM1	HSF	
TM10	a_p max. [mm]		
TM1005R-	1.5 *	31144458	
TM1008R-	1.8 *	31144459	
TM1010R-	2 *	31144460	31144461

8.5	1.5	10	2.6	3	0.5
8.5	1.8	10	2.6	3	0.8
8.5	2	10	2.6	3	1

Cutting edge design	HM1	HSF	
TM12	a_p max. [mm]		
TM1205R-	1.5 *	31144462	
TM1210R-	2 *	31144463	31144464
TM1220R-	3 *	31144465	

10	1.5	12	3	3.5	0.5
10	2	12	3	3.5	1
10	3	12	3	3.5	2

Cutting edge design	HM1	HSF	
TM16	a_p max. [mm]		
TM1610R-	2 *	31144467	31144468
TM1630R-	4 *	31144469	

12	2	16	4	4	1
12	4	16	4	4	3

Cutting edge design	HM1	HSF	
TM20	a_p max. [mm]		
TM2010R-	2 *	31144471	31144472
TM2040R-	5 *	31144473	

15	2	20	5	5	1
15	5	20	5	5	4

Cutting edge design	HM1	HSF	
TM25	a_p max. [mm]		
TM2510R-	2 *	31144475	31144476
TM2550R-	6 *	31144477	

18.5	2	25	6	6	1
18.5	6	25	6	6	5

Additional radii available upon request

* a_p max. depends on the type of milling cutter and application.

Feed per tooth (selection according to chip guiding stage)

MMG*	Chip guiding stage	TM_08			TM_10			TM_12												
		a _p max. [mm]		f _z [mm/tooth]	a _p max. [mm]		f _z [mm/tooth]	a _p max. [mm]		f _z [mm/tooth]										
P	H	HSF	0.1	0.2	***	0.05	0.15	0.25	0.1	0.25	***	0.08	0.17	0.25	0.1	0.3	***	0.1	0.2	0.3
		HM1	0.1	0.25	***	0.1	0.2	0.3	0.1	0.3	***	0.1	0.2	0.3	0.1	0.3	***	0.1	0.2	0.35

MMG*	Chip guiding stage	TM_16			TM_20			TM_25												
		a _p max. [mm]		f _z [mm/tooth]	a _p max. [mm]		f _z [mm/tooth]	a _p max. [mm]		f _z [mm/tooth]										
P	H	HSF	0.15	0.3	***	0.1	0.22	0.35	0.2	0.35	***	0.12	0.26	0.4	0.2	0.4	***	0.2	0.3	0.45
		HM1	0.15	0.35	***	0.1	0.25	0.4	0.2	0.4	***	0.2	0.27	0.45	0.5	0.45	***	0.2	0.35	0.5

*** a_p max. = dimension "l" can be taken from the table on page 266.

Cutting speed (selection according to cutting material type and contact ratio a_e/D)

IMB00-B2, IMB10-B2, IMB20-B2, IMT00-B2, IMT20-B2

MMG*		Workpiece material	Strength/ hardness [N/mm ²] [HRC]	Cooling			Cutting material type according to contact ratio a _e /D								
				MQL/Air	Dry	Wet	Carbide PVD-coated								
							HP310		HP315		HP320		HP325		
P	P1	P1.1	Structural, machining, case hardened and tempering steels, unalloyed	< 700	✓		240	380	240	380	220	350	200	340	
		P1.2	Structural, machining, case hardened and tempering steels, unalloyed	< 1,200	✓		220	340	220	340	200	320	180	320	
	P2	P2.1	Nitriding, hardening and tempering steels, alloyed	< 900	✓		200	320	200	320	180	300	170	300	
		P2.2	Nitriding, hardening and tempering steels, alloyed	< 1,400	✓		180	300	180	300	160	280	160	270	
	P3	P3.1	Tool, bearing, spring and high-speed steels**	< 800	✓		200	320	200	320	180	300	170	300	
		P3.2	Tool, bearing, spring and high-speed steels**	< 1,000	✓		200	320	200	320	180	300	170	300	
		P3.3	Tool, bearing, spring and high-speed steels**	< 1,500	✓		180	300	180	300	160	280	160	270	
	P5	P5.1	Cast steel		✓		200	300	200	300	170	280	150	270	
	H	H1	H1.1	Hardened steel / cast steel	< 44 HRC	✓		90	290	90	290	80	270	90	180
			H1.2	Hardened steel / cast steel	< 55 HRC	✓		70	230	70	230	60	210	60	170
H2		H2.1	Hardened steel / cast steel	< 60 HRC	✓		60	190	60	190	50	170	50	130	
		H2.2	Hardened steel / cast steel	< 65 HRC	✓		50	140	50	140	40	120			
		H2.3	Hardened steel / cast steel	< 68 HRC	✓										
H3		H3.1	Wear-resistant cast/chill casting, GJN		✓		60	140	60	140	50	120			

* MAPAL machining groups

** If the alloy parts Cr, Mo, Ni, V, W in total > 8%, then select the next highest MAPAL machining group.

The specified machining values are guide values.

The optimum data for the respective machining task should be determined during the test or machining.

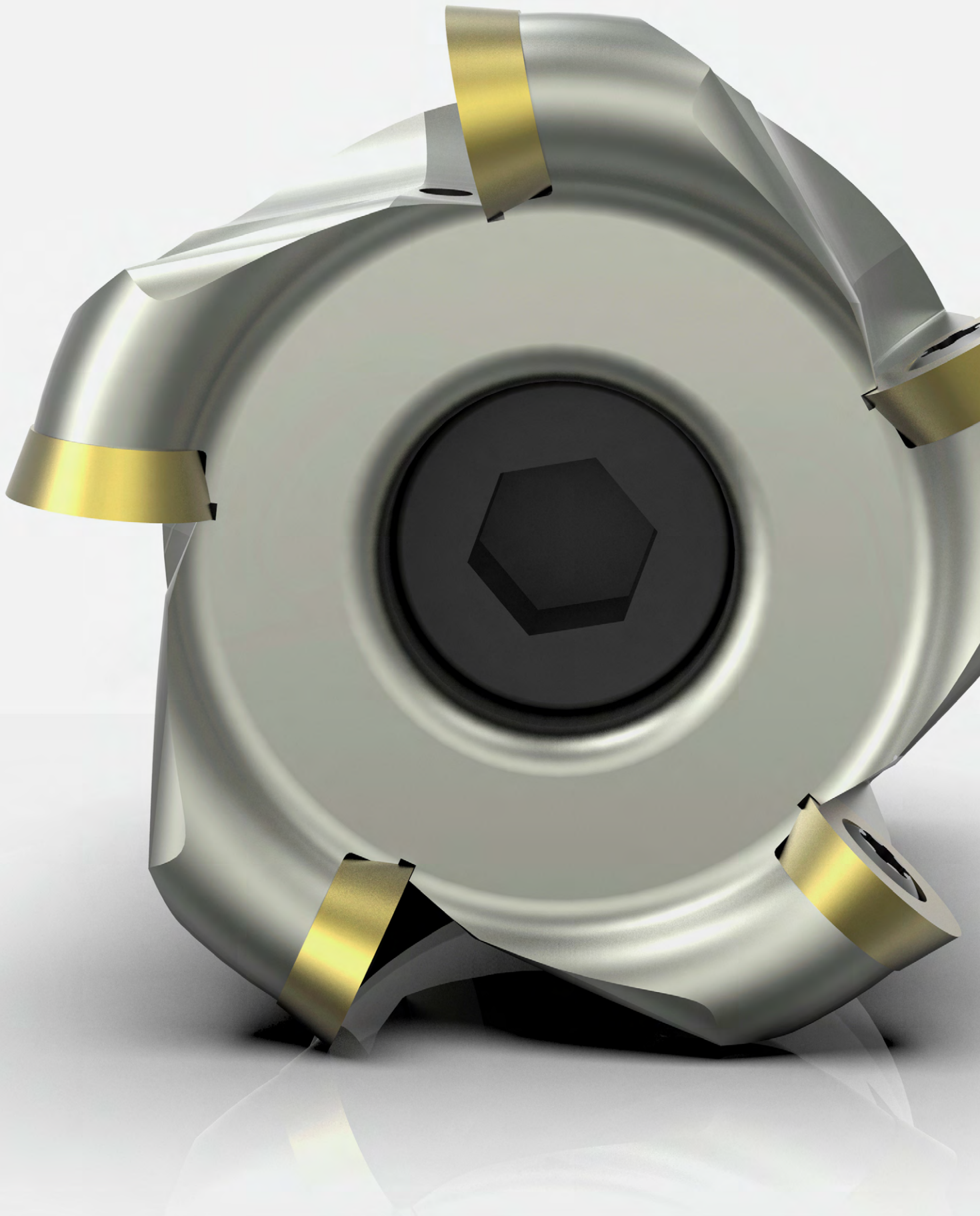



ROUND-INSERT MILLING CUTTERS

NeoMill-ISO-360

RD__05, Radius 2.5 mm	_____	270
RD__07, Radius 3.5 mm	_____	272
RD__10, Radius 5 mm	_____	274
RD__12, Radius 6 mm	_____	276
RD__16, Radius 8 mm	_____	278

Radial indexable insert

RDKW - RDKT - RDHW - RDHT, Round insert	_____	280
---	-------	-----

Accessories and spare parts

Allocating milling cutter clamping screws	_____	312
Accessories for radial indexable inserts	_____	313

Technical appendix

Cutting data recommendations	_____	282
------------------------------	-------	-----

NeoMill®-ISO-360

Round-insert milling cutter, radius 2.5 mm
RD__05

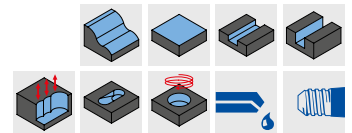
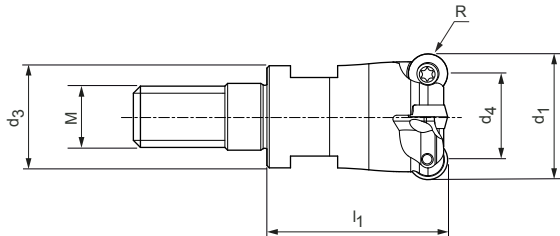

Screw-in milling cutter, cylindrical design

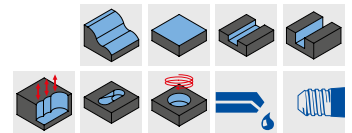
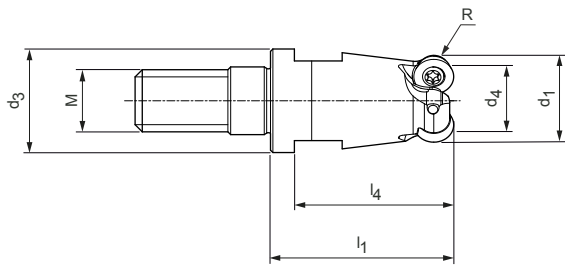

Dimensions					Z _{eff}	R	SW	Weight [kg]	Internal cooling	Specification	Order no.
d ₁	M	d ₃	d ₄	l ₁							
15	8	13	10	23	4	2,5	10	0,02	✓	IMR001-015-M008-Z04R-RD__05	31144171
16	8	13	11	23	4	2,5	10	0,03	✓	IMR001-016-M008-Z04R-RD__05	31144172
20	10	18	15	30	5	2,5	15	0,06	✓	IMR001-020-M010-Z05R-RD__05	31144173
25	12	21	20	35	6	2,5	17	0,10	✓	IMR001-025-M012-Z06R-RD__05	31144174



Screw-in milling cutter, conical design

Dimensions						Z _{eff}	R	SW	Weight [kg]	Internal cooling	Specification	Order no.
d ₁	M	d ₃	d ₄	l ₁	l ₄							
10	8	13	5	23	17,8	2	2,5	10	0,02	✓	IMR101-010-M008-Z02R-RD__05	31144164
12	8	13	7	23	17,8	3	2,5	10	0,02	✓	IMR101-012-M008-Z03R-RD__05	31144165

Accessories

	RD__05	Indexable insert	Page 280
		MFS milling head holder for screw-in milling cutter	Page 446

Spare parts*

	RD__05	Clamping screw for indexable insert M1.8X3.7-TX6-IP	Order no. 31161858
---	--------	--	-----------------------

Dimensions in mm.

The maximum operating speeds refer only to the cutting edge system.

* Included in scope of delivery.

Depending on the clamping device used, different maximum operating speeds must be observed.

NeoMill®-ISO-360

Round-insert milling cutter, radius 3.5 mm

RD__07

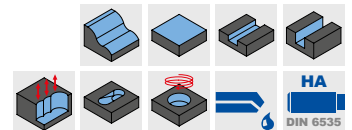
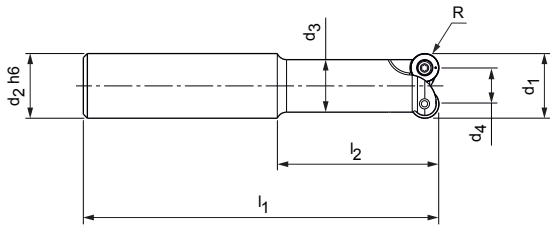

End milling cutter, cylindrical design

Dimensions						Z _{eff}	R	Weight [kg]	Internal cooling	Specification	Order no.
d ₁	d ₂ h6	d ₃	d ₄	l ₁	l ₂						
15	16	13	8	88	40	2	3,5	0,11	✓	IMR001-015-088-HA16-Z2R-RD__07	31144105
16	16	13	9	88	40	2	3,5	0,11	✓	IMR001-016-088-HA16-Z2R-RD__07	31144106

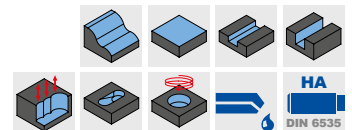
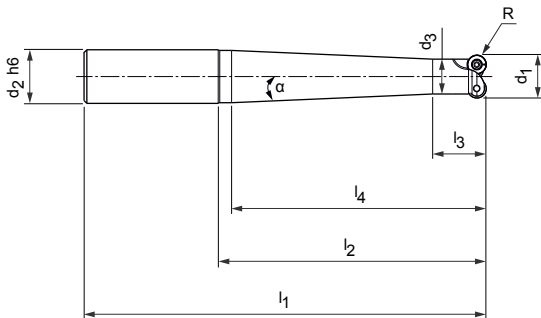

End milling cutter, conical design

Dimensions								Z _{eff}	R	Weight [kg]	Internal cooling	Specification	Order no.
d ₁	d ₂ h6	d ₃	l ₁	l ₂	l ₃	l ₄	α						
15	16	13	108	60	20	55	2,0°	2	3,5	0,14	✓	IMR101-015-108-HA16-Z2R-RD__07	31144092
15	20	13	130	80	20	75	3,4°	2	3,5	0,23	✓	IMR101-015-130-HA20-Z2R-RD__07	31144093
15	20	13	150	100	20	95	2,5°	2	3,5	0,26	✓	IMR101-015-150-HA20-Z2R-RD__07	31144094
15	25	13	176	120	20	115	3,5°	2	3,5	0,45	✓	IMR101-015-176-HA25-Z2R-RD__07	31144095
16	16	13	108	60	20	55	2,0°	2	3,5	0,14	✓	IMR101-016-108-HA16-Z2R-RD__07	31144096
16	20	13	130	80	20	75	3,4°	2	3,5	0,24	✓	IMR101-016-130-HA20-Z2R-RD__07	31144097
16	20	13	150	100	20	95	2,5°	2	3,5	0,27	✓	IMR101-016-150-HA20-Z2R-RD__07	31144098
16	25	13	176	120	20	115	3,5°	2	3,5	0,45	✓	IMR101-016-176-HA25-Z2R-RD__07	31144099

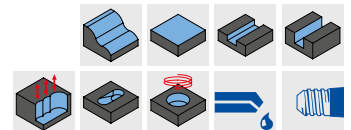
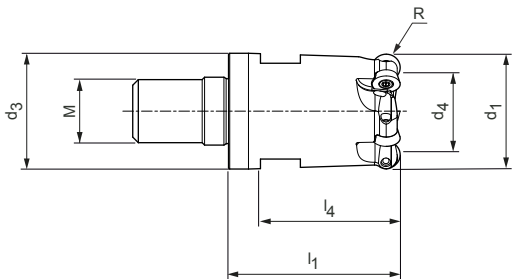

Screw-in milling cutter, conical design

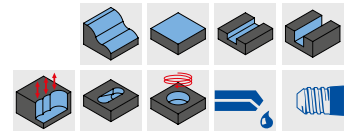
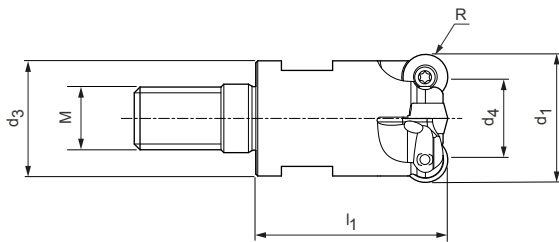

Dimensions						Z _{eff}	R	SW	Weight [kg]	Internal cooling	Specification	Order no.
d ₁	M	d ₃	d ₄	l ₁	l ₄							
30	16	29	23	43	38	5	3,5	24	0,21	✓	IMR101-030-M016-Z05R-RD__07	31144166



Screw-in milling cutter, cylindrical design

Dimensions					Z _{eff}	R	SW	Weight [kg]	Internal cooling	Specification	Order no.
d ₁	M	d ₃	d ₄	l ₁							
15	8	13	8	23	2	3,5	10	0,02	✓	IMR001-015-M008-Z02R-RD__07	31144175
15	8	13	8	23	3	3,5	10	0,02	✓	IMR001-015-M008-Z03R-RD__07	31144176
16	8	13	9	23	2	3,5	10	0,02	✓	IMR001-016-M008-Z02R-RD__07	31144177
16	8	13	9	23	3	3,5	10	0,02	✓	IMR001-016-M008-Z03R-RD__07	31144178
20	10	18	13	30	4	3,5	15	0,05	✓	IMR001-020-M010-Z04R-RD__07	31144179
25	12	21	18	35	5	3,5	17	0,09	✓	IMR001-025-M012-Z05R-RD__07	31144180
32	16	29	25	43	6	3,5	24	0,22	✓	IMR001-032-M016-Z06R-RD__07	31144181
35	16	29	28	43	6	3,5	24	0,23	✓	IMR001-035-M016-Z06R-RD__07	31144182

Accessories

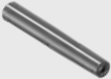
	RD__07	Indexable insert	Page 280
		Chuck for end milling cutter	Page 446
		MFS milling head holder for screw-in milling cutter	Page 446

Spare parts*

	RD__07	Clamping screw for indexable insert M2.5X5.5-TX7-IP	Order no. 31161854
---	--------	---	-----------------------

Dimensions in mm.
The maximum operating speeds refer only to the cutting edge system.
* Included in scope of delivery.

Depending on the clamping device used, different maximum operating speeds must be observed.

NeoMill®-ISO-360

Round-insert milling cutter, radius 5 mm
RD__10

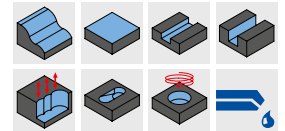
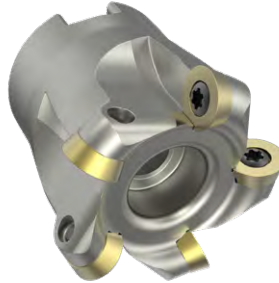
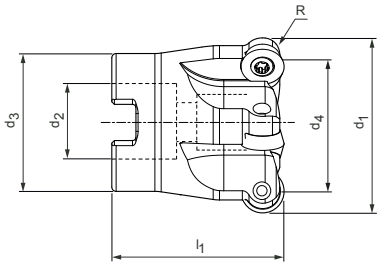

Milling cutter

Dimensions					Z _{eff}	R	Weight [kg]	Internal cooling	Specification	Order no.
d ₁	d ₂	d ₃	d ₄	l ₁						
40	16	32	30	40	5	5	0,18	✓	IMR001-040-CA16-Z05R-RD__10	31143968
42	16	32	32	40	5	5	0,2	✓	IMR001-042-CA16-Z05R-RD__10	31143969
52	22	40	42	50	5	5	0,4	✓	IMR001-052-CA22-Z05R-RD__10	31144030
52	22	40	42	50	7	5	0,3	✓	IMR001-052-CA22-Z07R-RD__10	31144031

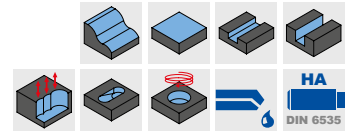
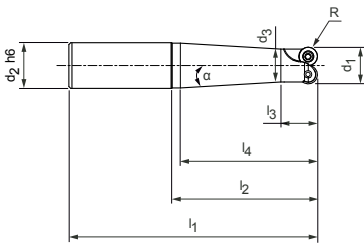

End milling cutter, conical design

Dimensions								Z _{eff}	R	Weight [kg]	Internal cooling	Specification	Order no.
d ₁	d ₂ h6	d ₃	l ₁	l ₂	l ₃	l ₄	α						
20	20	18	90	40	20	35	2,9°	2	5	0,18	✓	IMR101-020-090-HA20-Z2R-RD__10	31144100
20	20	18	110	60	20	55	1,3°	2	5	0,22	✓	IMR101-020-110-HA20-Z2R-RD__10	31144101
20	25	18	136	80	20	75	3,4°	2	5	0,4	✓	IMR101-020-136-HA25-Z2R-RD__10	31144102
20	25	18	156	100	20	95	2,5°	2	5	0,45	✓	IMR101-020-156-HA25-Z2R-RD__10	31144103
20	25	18	176	120	20	115	2,0°	2	5	0,5	✓	IMR101-020-176-HA25-Z2R-RD__10	31144104

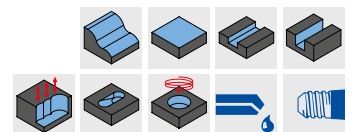
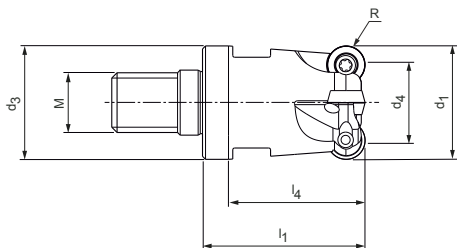

Screw-in milling cutter, conical design



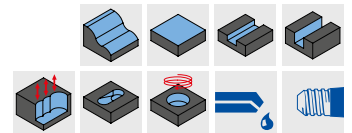
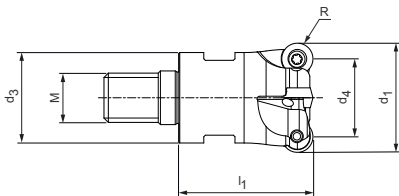

Dimensions						Z _{eff}	R	SW	Weight [kg]	Internal cooling	Specification	Order no.
d ₁	M	d ₃	d ₄	l ₁	l ₄							
30	16	29	20	43	38	4	5	24	0,2	✓	IMR101-030-M016-Z04R-RD__10	31144167
32	16	29	22	43	38	4	5	24	0,2	✓	IMR101-032-M016-Z04R-RD__10	31144168



Screw-in milling cutter, cylindrical design

Dimensions					z _{eff}	R	SW	Weight [kg]	Internal cooling	Specification	Order no.
d ₁	M	d ₃	d ₄	l ₁							
20	10	18	10	30	2	5	15	0,05	✓	IMR001-020-M010-Z02R-RD__10	31144183
25	12	21	15	35	3	5	17	0,08	✓	IMR001-025-M012-Z03R-RD__10	31144184
35	16	29	25	43	4	5	24	0,22	✓	IMR001-035-M016-Z04R-RD__10	31144185
35	16	29	25	43	5	5	24	0,22	✓	IMR001-035-M016-Z05R-RD__10	31144186
40	16	29	30	43	5	5	24	0,23	✓	IMR001-040-M016-Z05R-RD__10	31144187
42	16	29	32	43	5	5	24	0,24	✓	IMR001-042-M016-Z05R-RD__10	31144188
42	16	29	32	43	6	5	24	0,25	✓	IMR001-042-M016-Z06R-RD__10	31144189

Accessories

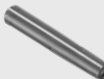
	RD__10	Indexable insert	Page 280
		Milling cutter arbor for milling cutter	Page 446
		Milling cutter clamping screws for milling cutter	Page 312
		Chuck for end milling cutter	Page 446
		MFS milling head holder for screw-in milling cutter	Page 446

Spare parts*

	RD__10	Clamping screw for indexable insert M3.5X7.2-TX15-IP	Order no. 31161859
---	--------	--	-----------------------

Dimensions in mm.

The maximum operating speeds refer only to the cutting edge system.

* Included in scope of delivery.

Depending on the clamping device used, different maximum operating speeds must be observed.

NeoMill®-ISO-360

Round-insert milling cutter, radius 6 mm
RD__12

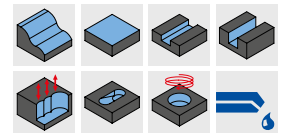
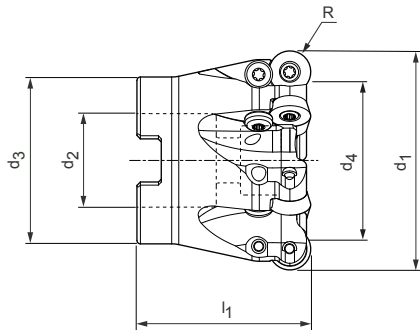

Milling cutter

Dimensions					z _{eff}	R	Weight [kg]	Internal cooling	Specification	Order no.
d ₁	d ₂	d ₃	d ₄	l ₁						
42	16	32	30	40	4	6	0,14	✓	IMR001-042-CA16-Z04R-RD__12	31144032
48	22	40	36	50	4	6	0,32	✓	IMR001-048-CA22-Z04R-RD__12	31144033
50	22	40	38	50	5	6	0,36	✓	IMR001-050-CA22-Z05R-RD__12	31144034
52	22	40	40	50	5	6	0,34	✓	IMR001-052-CA22-Z05R-RD__12	31144035
63	27	48	51	50	6	6	0,52	✓	IMR001-063-CA27-Z06R-RD__12	31144036
66	27	48	54	50	6	6	0,58	✓	IMR001-066-CA27-Z06R-RD__12	31144037
80	27	60	68	52	7	6	0,99	✓	IMR001-080-CA27-Z07R-RD__12	31144038

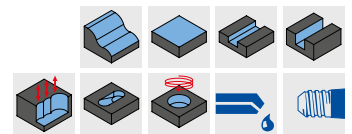
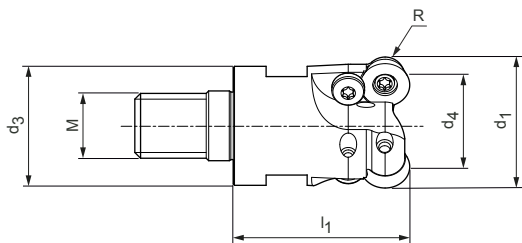

Screw-in milling cutter, cylindrical design



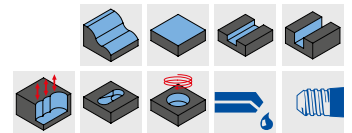
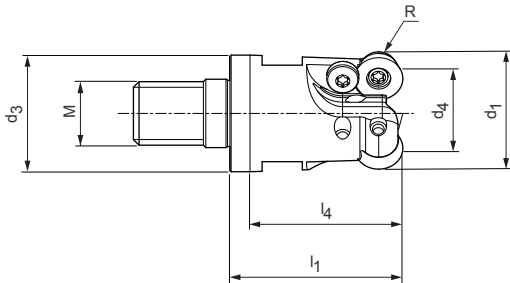

Dimensions					z _{eff}	R	SW	Weight [kg]	Internal cooling	Specification	Order no.
d ₁	M	d ₃	d ₄	l ₁							
25	12	21	13	35	2	6	17	0,08	✓	IMR001-025-M012-Z02R-RD__12	31144190
35	16	29	23	43	3	6	24	0,19	✓	IMR001-035-M016-Z03R-RD__12	31144191
40	16	29	28	43	2	6	24	0,21	✓	IMR001-040-M016-Z04R-RD__12	31144192
42	16	29	30	43	4	6	24	0,23	✓	IMR001-042-M016-Z04R-RD__12	31144193





Screw-in milling cutter, conical design

Dimensions						Z _{eff}	R	SW	Weight [kg]	Internal cooling	Specification	Order no.
d ₁	M	d ₃	d ₄	l ₁	l ₄							
32	16	29	20	43	38	3	6	24	0,18	✓	IMR101-032-M016-Z03R-RD__12	31144169

Accessories

	RD__12	Indexable insert	Page 280
		Milling cutter arbor for milling cutter	Page 446
		Milling cutter clamping screws for milling cutter	Page 312
		MFS milling head holder for screw-in milling cutter	Page 446

Spare parts*

	RD__12	Clamping screw for indexable insert M3.5X8.6-TX15-IP	Order no. 31161860
	RD__12	Rotation lock M3.5X7.2-TX15-IP	Order no. 31161928

Dimensions in mm.

The maximum operating speeds refer only to the cutting edge system.

* Included in scope of delivery.

Depending on the clamping device used, different maximum operating speeds must be observed.

NeoMill®-ISO-360

Round-insert milling cutter, radius 8 mm
RD__16

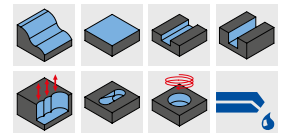
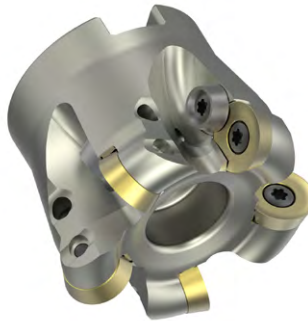
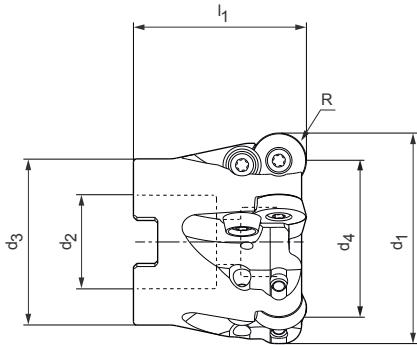

Milling cutter

Dimensions					z _{eff}	R	Weight [kg]	Internal cooling	Specification	Order no.
d ₁	d ₂	d ₃	d ₄	l ₁						
50	22	40	34	50	4	8	0,27	✓	IMR001-050-CA22-Z04R-RD__16	31144039
52	22	40	36	50	4	8	0,3	✓	IMR001-052-CA22-Z04R-RD__16	31144040
63	27	48	47	50	5	8	0,44	✓	IMR001-063-CA27-Z05R-RD__16	31144041
66	27	48	50	50	5	8	0,67	✓	IMR001-066-CA27-Z05R-RD__16	31144042
80	27	60	64	52	6	8	0,99	✓	IMR001-080-CA27-Z06R-RD__16	31144044
80	27	60	64	52	7	8	0,97	✓	IMR001-080-CA27-Z07R-RD__16	31144045
100	32	70	84	52	7	8	1,28	✓	IMR001-100-CA32-Z07R-RD__16	31144046
125	40	90	109	63	8	8	2,66	✓	IMR001-125-CA40-Z08R-RD__16	31144047
160	40	128	144	63	9	8	4,18	✓	IMR001-160-CA40-Z09R-RD__16	31144048

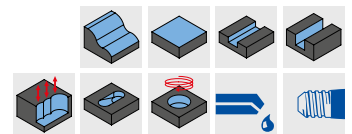
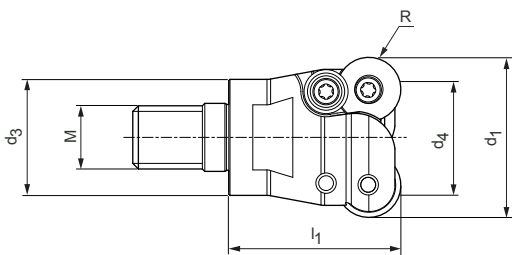

Screw-in milling cutter, cylindrical design

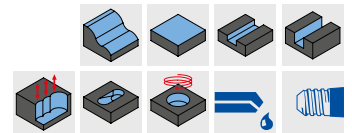
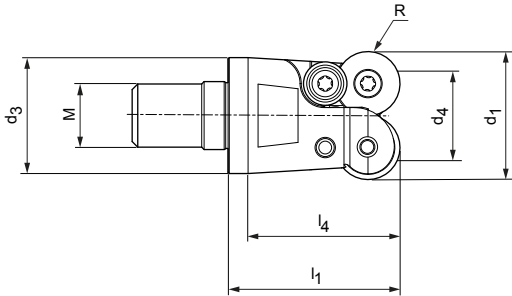

Dimensions					z _{eff}	R	SW	Weight [kg]	Internal cooling	Specification	Order no.
d ₁	M	d ₃	d ₄	l ₁							
40	16	29	24	43	2	8	24	0,23	✓	IMR001-040-M016-Z02R-RD__16	31144194





Screw-in milling cutter, conical design

Dimensions						Z _{eff}	R	SW	Weight [kg]	Internal cooling	Specification	Order no.
d ₁	M	d ₃	d ₄	l ₁	l ₄							
32	16	29	16	43	38	2	8	24	0,18	✓	IMR101-032-M016-Z02R-RD__16	31144170

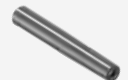
Accessories

	RD__16	Indexable insert	Page 280
		Milling cutter arbor for milling cutter	Page 446
		Milling cutter clamping screws for milling cutter	Page 312
		MFS milling head holder for screw-in milling cutter	Page 446

Spare parts*

	RD__16	Clamping screw for indexable insert M4.5X10.5-TX20-IP	Order no. 31161861
	RD__16	Clamping screw for clamping plate M4.5X10.5-TX20-IP	Order no. 31161861
	RD__16	Clamping plate	Order no. 31161929

Dimensions in mm.

The maximum operating speeds refer only to the cutting edge system.

* Included in scope of delivery.

Depending on the clamping device used, different maximum operating speeds must be observed.

RDKW – RDKT – RDHW – RDHT

Radial indexable insert, round insert

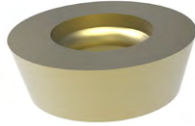

	Carbide			
Workpiece material	P		M	
	Unalloyed ← Wear-resistant	Alloyed → Toughened	Austenitic ← Wear-resistant	Ferritic → Toughened
Coating	PVD		PVD	
Cutting material type	HP635	HP640	HP650	HP655
Cutting edge design	PMU	PMU	MMU	MMU

	RDKW	a_p max. [mm]			
RDKW0501M0N-	1.2 *	31144308		31144305	31144306
RDKW0702M0N-	1.7 *	31144318	31144319	31144314	31144315
RDKW1003M0N-	2.5 *	31144329	31144330	31144325	31144326
RDKW12T3M0N-	3 *	31144338	31144339		
RDKW1604M0N-	4 *	31144347	31144348		
	RDKT				
RDKT12T3M0N-	3 *	31144292	31144293	31144288	31144289
RDKT1604M0N-	4 *	31144298	31144299	31144294	31144295
	RDHW				
RDHW0501M0N-	0.45 *				
RDHW0702M0N-	0.85 *				
RDHW1003M0N-	1.2 *				
RDHW12T3M0N-	1.5 *				
RDHW1604M0N-	2 *				
	RDHT				
RDHT12T3M0N-	3 *			31144283	31144284

Feed per tooth (selection according to chip guiding stage)

# MMG	Chip guiding stage	RD_0501						RD_0702					
		a _p max. [mm]			f _z [mm/tooth]			a _p max. [mm]			f _z [mm/tooth]		
P	PMU	0.25	0.7	1.2	0.14	0.26	0.5	0.25	1	1.7	0.14	0.27	0.6
M	MMU	0.25	0.7	1.2	0.13	0.23	0.45	0.25	1	1.7	0.13	0.24	0.52
K	KMU	0.25	0.7	1.2	0.15	0.27	0.53	0.25	1	1.7	0.15	0.28	0.63
H	HFU	0.1	0.18	0.45	0.1	0.2	0.36	0.1	0.2	0.65	0.11	0.22	0.42
	HMU	0.1	0.18	0.45	0.1	0.2	0.36	0.1	0.2	0.65	0.11	0.22	0.42
	HRU	0.12	0.24	0.6	0.1	0.22	0.4	0.12	0.25	0.85	0.11	0.25	0.46

* a_p max. depends on the type of milling cutter and application.

** MAPAL machining groups

Cutting data recommendations for milling cutter with indexable inserts

Cutting speed (selection according to cutting material type and contact ratio a_e/D)

IMR00-R, IMR10-R

MMG*		Workpiece material	Strength/hardness [N/mm ²] [HRC]	Cooling			Cutting material type according to contact ratio a_e/D			
				MQL/Air	Dry	Wet	Carbide PVD-coated			
							HP310		HP320	
							>0.6	<0.6	>0.6	<0.6
P	P1	P1.1	Structural, machining, case hardened and tempering steels, unalloyed	< 700		✓				
		P1.2	Structural, machining, case hardened and tempering steels, unalloyed	< 1,200		✓				
	P2	P2.1	Nitriding, hardening and tempering steels, alloyed	< 900		✓				
		P2.2	Nitriding, hardening and tempering steels, alloyed	< 1,400		✓				
	P3	P3.1	Tool, bearing, spring and high-speed steels**	< 800		✓				
		P3.2	Tool, bearing, spring and high-speed steels**	< 1,000		✓				
		P3.3	Tool, bearing, spring and high-speed steels**	< 1,500		✓				
	P4	P4.1	Stainless steels, ferritic and martensitic							
	P5	P5.1	Cast steel							
	P6	P6.1	Stainless cast steels, ferritic and martensitic							
M	M1	M1.1	Stainless steels, austenitic	< 700		✓				
		M1.2	Stainless steels, ferritic/austenitic (duplex)	< 1,000						
	M2	M2.1	Stainless cast steel, austenitic	< 700						
		M3.1	Stainless cast steel, ferritic/austenitic (duplex)	< 1,000						
K	K1	K1.1	Cast iron with lamellar graphite (grey cast iron), GJL	< 300		✓				
		K2.1	Cast iron with spheroidal graphite, GJS	< 500		✓				
	K2	K2.2	Cast iron with spheroidal graphite, GJS	≤ 800						
		K2.3	Cast iron with spheroidal graphite, GJS	> 800						
	K3	K3.1	Cast iron with vermicular graphite, GJV; malleable cast iron, GJM	< 500						
		K3.2	Cast iron with vermicular graphite, GJV; malleable cast iron, GJM	> 500						
H	H1	H1.1	Hardened steel / cast steel	< 44 HRC		✓	90	290	80	270
		H1.2	Hardened steel / cast steel	< 55 HRC		✓	70	230	60	210
	H2	H2.1	Hardened steel / cast steel	< 60 HRC		✓	60	190	50	170
		H2.2	Hardened steel / cast steel	< 65 HRC		✓	50	140	40	120
	H3	H2.3	Hardened steel / cast steel	< 68 HRC		✓				
		H3.1	Wear-resistant cast/chill casting, GJN			✓	60	140	50	120

Plunge angle | Screw-in and end milling cutter

Diameter [mm]	Plunge angle [°]				
	RD_05	RD_07	RD_10	RD_12	RD_16
10	28.9	-	-	-	-
12	13.8	-	-	-	-
15	8.6	20	-	-	-
16	7.7	16.8	-	-	-
20	6.9	11	39	-	-
25	4	7.3	14.3	26	-
30	-	5.4	9.3	-	-
32	-	4.9	8.6	14.3	29.6
35	-	4.3	7.3	11.9	-
40	-	-	5.8	9.3	15
42	-	-	5.4	8.3	-

Plunge angle | Milling cutter

Diameter [mm]	Plunge angle [°]		
	RD_10	RD_12	RD_16
40	7	-	-
42	6.7	7.5	-
48	-	6.5	-
50	-	6.1	9.5
52	5.5	5.7	8.8
63	-	4.3	7.1
66	-	4.1	6
80	-	3.2	4.5
100	-	-	3.7
125	-	-	2.8
160	-	-	1.8

* MAPAL machining groups

** If the alloy parts Cr, Mo, Ni, V, W in total > 8%, then select the next highest MAPAL machining group.

Cutting material type according to contact ratio a_e/D													
Carbide PVD-coated												Carbide CVD-coated	
HP325		HP630		HP635		HP640		HP650		HP655		HC220	
>0.6	<0.6	>0.6	<0.6	>0.6	<0.6	>0.6	<0.6	>0.6	<0.6	>0.6	<0.6	>0.6	<0.6
				230	300	200	260						
				200	270	170	230						
				210	280	180	240						
				180	250	150	210						
				190	250	170	220						
				170	230	160	210						
				150	210	140	190						
				150	210								
				160	220								
				140	200								
								140	180	130	160		
								110	150	100	130		
								110	130	100	120		
								80	100	70	90		
		230	360										
		200	250										
		190	230										
		180	210										
		190	230										
		180	210										
90	180											80	270
60	170											60	190
50	130											50	150
												40	120
												50	120

The specified machining values are guide values.
 The optimum data for the respective machining task should be determined during the test or machining.



HIGH-FEED AND 90° SHOULDER MILLING CUTTERS



NeoMill-2-HiFeed90

LP__06	286
LD__10	288
LD__18	290

NeoMill-4-HiFeed90

SD__06	292
SD__10	294
SD__14	296
SD__18	297

Radial indexable inserts

LPMX - LDGX - LDMX - LDHX, 90° machining	298
LPMX - LDMX, high-feed machining	300
SDHT - SDMT, 90° machining	302
SDMT - SDMw, high-feed machining	304

Accessories and spare parts

Allocating milling cutter clamping screws	312
Accessories for radial indexable inserts	313

Technical appendix

Cutting data recommendations	306
------------------------------	-----

NeoMill®-2-HiFeed90

High-feed and 90° shoulder milling cutter
LP_06

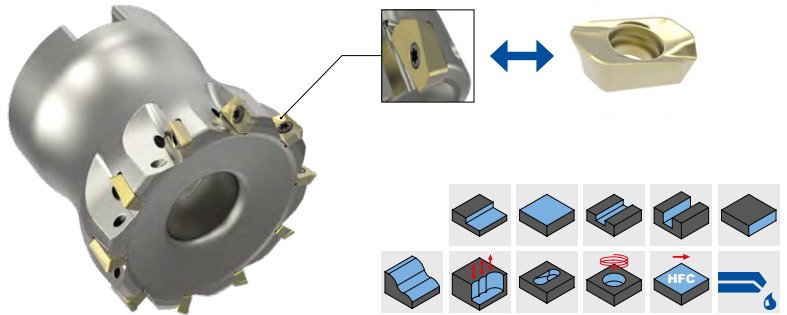
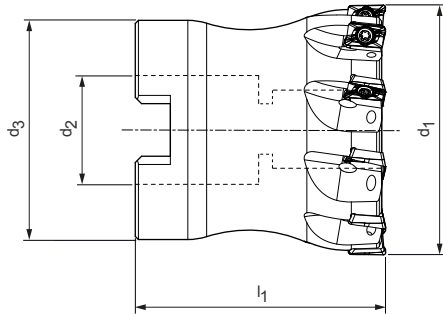

Milling cutter

Dimensions				Z _{eff}	a _p max.		Weight [kg]	Internal cooling	Specification	Order no.
d ₁	d ₂	d ₃	l ₁		90°	HFC				
32	16	25	40	8	5,2	0,7	0,11	✓	IMH901-032-CA16-Z08R-LP_06	31146643
40	16	35	40	10	5,2	0,7	0,23	✓	IMH901-040-CA16-Z10R-LP_06	31146644
50	22	43	40	11	5,2	0,7	0,35	✓	IMH901-050-CA22-Z11R-LP_06	31146645

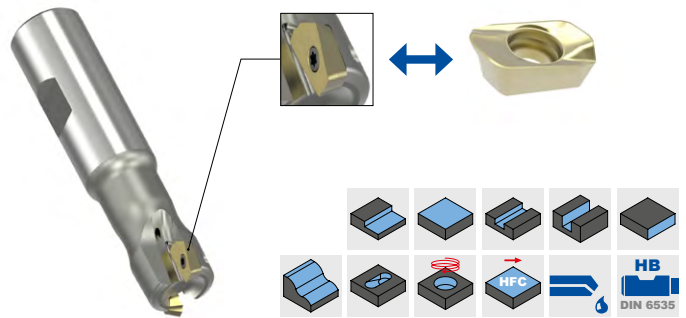
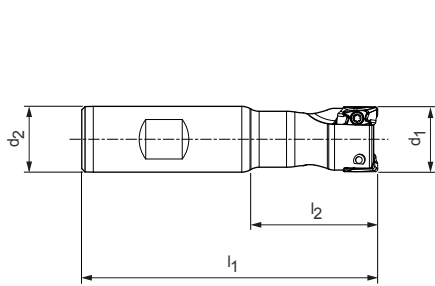

End milling cutter

Dimensions				Z _{eff}	a _p max.		Weight [kg]	Internal cooling	Specification	Order no.
d ₁	d ₂	l ₁	l ₂		90°	HFC				
10	10	80	28	2	5,2	0,7	0,04	✓	IMH901-010-080-HA10-Z2R-LP_06	31146637
12	12	80	30	3	5,2	0,7	0,06	✓	IMH901-012-080-HA12-Z3R-LP_06	31146638
16	16	85	35	4	5,2	0,7	0,11	✓	IMH901-016-085-HB16-Z4R-LP_06	31146639
20	20	90	40	5	5,2	0,7	0,18	✓	IMH901-020-090-HB20-Z5R-LP_06	31146640
25	25	106	50	7	5,2	0,7	0,34	✓	IMH901-025-106-HB25-Z7R-LP_06	31146641



Screw-in milling cutter

Dimensions				Z _{eff}	a _p max.		SW	Weight [kg]	Internal cooling	Specification	Order no.
d ₁	M	d ₃	l ₁		90°	HFC					
10	6	9,8	15,5	2	5,2	0,7	8	0,01	✓	IMH901-010-M006-Z02R-LP__06	31146651
12	6	9,8	15,5	3	5,2	0,7	8	0,01	✓	IMH901-012-M006-Z03R-LP__06	31146652
16	8	13,8	20,5	4	5,2	0,7	12	0,03	✓	IMH901-016-M008-Z04R-LP__06	31146653
20	10	18	27	5	5,2	0,7	16	0,06	✓	IMH901-020-M010-Z05R-LP__06	31146654
25	12	21	30	7	5,2	0,7	18	0,09	✓	IMH901-025-M012-Z07R-LP__06	31146655
32	16	29	43	8	5,2	0,7	24	0,23	✓	IMH901-032-M016-Z08R-LP__06	31146656

Accessories

	LP__06	Indexable insert 90°	Page 298
	LP__06	Indexable insert HFC	Page 300
		Milling cutter arbor for milling cutter	Page 446
		Milling cutter clamping screws for milling cutter	Page 312
		Chuck for end milling cutter	Page 446
		MFS milling head holder for screw-in milling cutter	Page 446

CAM programming note

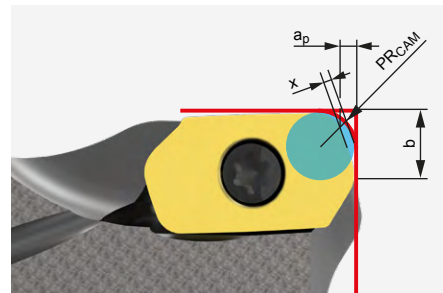

When using an HFC indexable insert, the programme radius PR_{CAM} must be observed.

LP__06

Dimensions [mm]			
PR _{CAM}	a _p	x	b
1,2	0,7	0,2	1,4

Spare parts*

	LP__06	Clamping screw for indexable insert M1.8X4.09-TX6-IP	Order no. 31164571
--	--------	--	-----------------------

Dimensions in mm.
The maximum operating speeds refer only to the cutting edge system.
* Included in scope of delivery.

Depending on the clamping device used, different maximum operating speeds must be observed.

NeoMill®-2-HiFeed90

High-feed and 90° shoulder milling cutter
LD__10

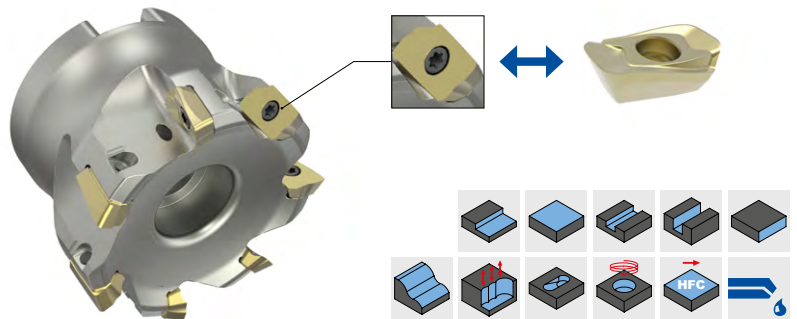
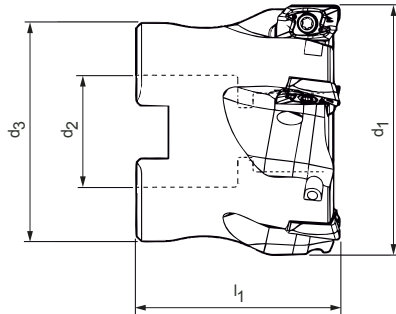

Milling cutter

Dimensions				Z _{eff}	a _p max.		Weight [kg]	Internal cooling	Specification	Order no.
d ₁	d ₂	d ₃	l ₁		90°	HFC				
40	16	35	40	4	9	1,4	0,19	✓	IMH901-040-CA16-Z04R-LD__10	31144049
40	16	35	40	6	9	1,4	0,19	✓	IMH901-040-CA16-Z06R-LD__10	31144050
50	22	43	40	5	9	1,4	0,29	✓	IMH901-050-CA22-Z05R-LD__10	31144051
50	22	43	40	7	9	1,4	0,29	✓	IMH901-050-CA22-Z07R-LD__10	31144052
63	22	48	40	6	9	1,4	0,48	✓	IMH901-063-CA22-Z06R-LD__10	31144053
63	22	48	40	8	9	1,4	0,46	✓	IMH901-063-CA22-Z08R-LD__10	31144054
80	27	60	50	10	9	1,4	0,92	✓	IMH901-080-CA27-Z10R-LD__10	31144055

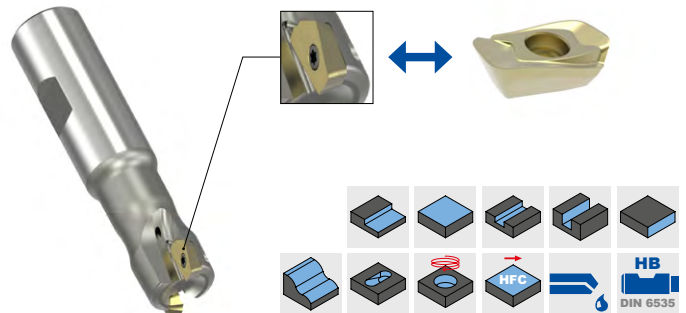
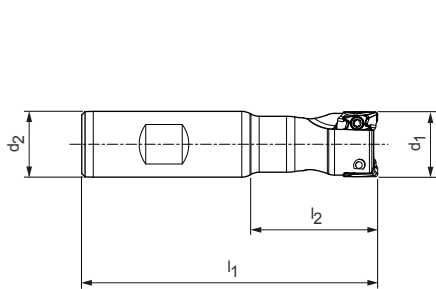

End milling cutter

Dimensions				Z _{eff}	a _p max.		Weight [kg]	Internal cooling	Specification	Order no.
d ₁	d ₂	l ₁	l ₂		90°	HFC				
16	16	85	37	2	9	1,4	0,1	✓	IMH901-016-085-HB16-Z2R-LD__10	31144149*
20	20	90	40	2	9	1,4	0,17	✓	IMH901-020-090-HB20-Z2R-LD__10	31144159*
20	20	90	40	3	9	1,4	0,17	✓	IMH901-020-090-HB20-Z3R-LD__10	31144151
25	25	106	50	3	9	1,4	0,32	✓	IMH901-025-106-HB25-Z3R-LD__10	31144152
25	25	106	50	4	9	1,4	0,32	✓	IMH901-025-106-HB25-Z4R-LD__10	31144153
32	32	124	64	3	9	1,4	0,65	✓	IMH901-032-124-HB32-Z3R-LD__10	31144154
32	32	124	64	5	9	1,4	0,64	✓	IMH901-032-124-HB32-Z5R-LD__10	31144155

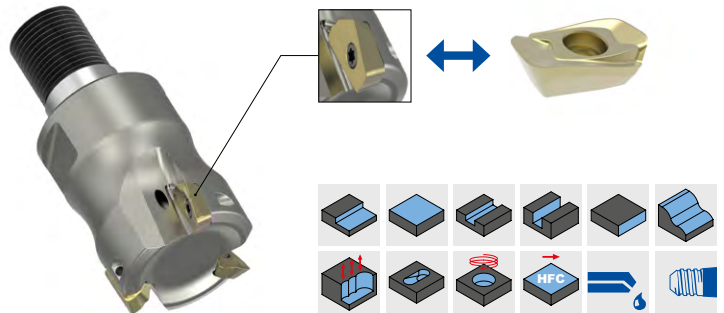
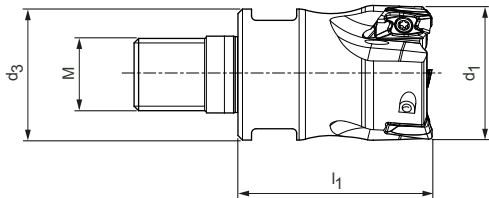

Screw-in milling cutter

Dimensions				Z _{eff}	a _p max.		SW	Weight [kg]	Internal cooling	Specification	Order no.
d ₁	M	d ₃	l ₁		90°	HFC					
16	8	13,8	31	2	9	1,4	12	0,03	✓	IMH901-016-M008-Z02R-LD__10	31144195*
20	10	18	29,8	3	9	1,4	16	0,04	✓	IMH901-020-M010-Z03R-LD__10	31144196*
25	12	21	32	3	9	1,4	18	0,07	✓	IMH901-025-M012-Z03R-LD__10	31144197*
25	12	21	32	4	9	1,4	18	0,07	✓	IMH901-025-M012-Z04R-LD__10	31144198*
32	16	29	43	3	9	1,4	24	0,22	✓	IMH901-032-M016-Z03R-LD__10	31144204
32	16	29	43	5	9	1,4	24	0,19	✓	IMH901-032-M016-Z05R-LD__10	31144199

Accessories

	LD__10	Indexable insert 90°	Page 298
	LD__10	Indexable insert HFC	Page 300
		Milling cutter arbor for milling cutter	Page 446
		Milling cutter clamping screws for milling cutter	Page 312
		Chuck for end milling cutter	Page 446
		MFS milling head holder for screw-in milling cutter	Page 446

CAM programming note

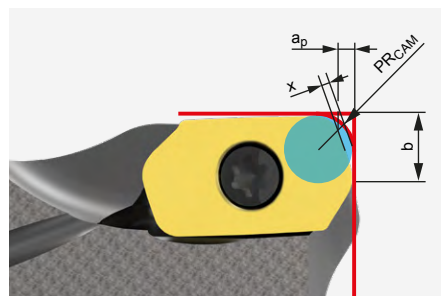

When using an HFC indexable insert, the programme radius PR_{CAM} must be observed.

LD__10

Dimensions [mm]			
PR _{CAM}	a _p	x	b
2,2	1,4	0,4	3,52

Spare parts**

		Clamping screw for indexable insert	Order no.
	***	M2.5X5.9-TX8-IP	31161842
	LD__10	M2.5X6.8-TX8-IP	31161843

Dimensions in mm.

The maximum operating speeds refer only to the cutting edge system.

* Use with clamping screw M2.5X5.9

** Included in scope of delivery.

*** Use the order numbers marked with *.

Depending on the clamping device used, different maximum operating speeds must be observed.

NeoMill®-2-HiFeed90

90° shoulder milling cutter

LD__18

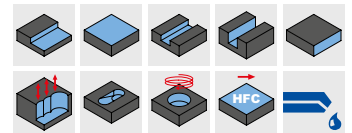
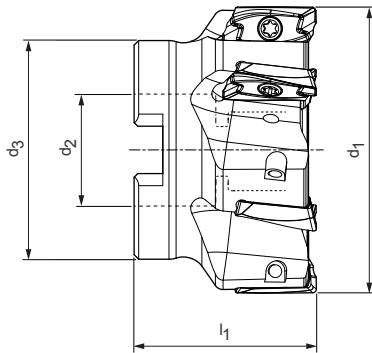

Milling cutter



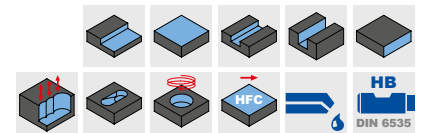
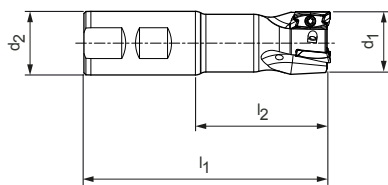

Dimensions				Z _{eff}	a _p max.	Weight [kg]	Internal cooling	Specification	Order no.
d ₁	d ₂	d ₃	l ₁						
40	16	35	40	4	17	0,16	✓	IMH901-040-CA16-Z04R-LD__18	31144077
50	22	43	40	5	17	0,27	✓	IMH901-050-CA22-Z05R-LD__18	31144074
52	22	43	40	5	17	0,28	✓	IMH901-052-CA22-Z05R-LD__18	31144078
63	22	48	40	5	17	0,43	✓	IMH901-063-CA22-Z05R-LD__18	31144079
66	22	48	40	6	17	0,51	✓	IMH901-066-CA22-Z06R-LD__18	31144080
80	27	60	50	7	17	0,85	✓	IMH901-080-CA27-Z07R-LD__18	31144081
100	32	78	50	8	17	1,49	✓	IMH901-100-CA32-Z08R-LD__18	31144082
125	40	90	60	9	17	2,79	✓	IMH901-125-CA40-Z09R-LD__18	31144083
160	40	115	60	10	17	3,65	-	IMH900-160-CA40-Z10R-LD__18	31144084



End milling cutter

Dimensions				Z _{eff}	a _p max.	Weight [kg]	Internal cooling	Specification	Order no.
d ₁	d ₂	l ₁	l ₂						
25	25	106	50	2	17	0,3	✓	IMH901-025-106-HB25-Z2R-LD__18	31144161
32	32	124	64	3	17	0,61	✓	IMH901-032-124-HB32-Z3R-LD__18	31144162
40	32	124	65	4	17	0,7	✓	IMH901-040-130-HB32-Z4R-LD__18	31144163

Accessories

	LD__18	Indexable insert 90°	Page 298
		Milling cutter arbor for milling cutter	Page 446
		Milling cutter clamping screws for milling cutter	Page 312
		Chuck for end milling cutter	Page 446

Spare parts*

	LD__18	Clamping screw for indexable insert M3.5X10-TX15-IP	Order no. 30870699
---	--------	---	-----------------------

Dimensions in mm.

The maximum operating speeds refer only to the cutting edge system.

* Included in scope of delivery.

Depending on the clamping device used, different maximum operating speeds must be observed.

NeoMill®-4-HiFeed90

High-feed milling cutter
SD_06

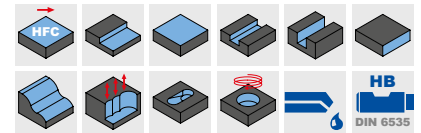
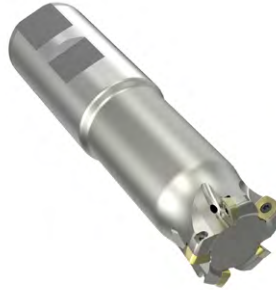
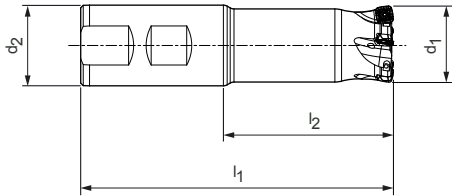

End milling cutter

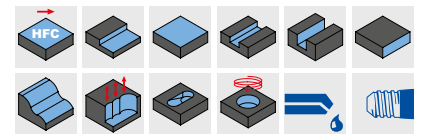
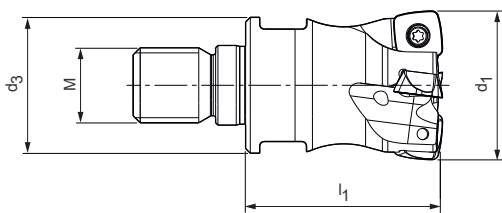

Dimensions				z _{eff}	a _p max.	Weight [kg]	Internal cooling	Specification	Order no.
d ₁	d ₂	l ₁	l ₂						
16	16	85	37	2	1	0,1	✓	IMH901-016-085-HB16-Z2R-SD_06	31146632
20	20	90	40	3	1	0,17	✓	IMH901-020-090-HB20-Z3R-SD_06	31146633
25	25	106	50	4	1	0,33	✓	IMH901-025-106-HB25-Z4R-SD_06	31146634
32	32	124	64	5	1	0,66	✓	IMH901-032-124-HB32-Z5R-SD_06	31146635
35	32	124	64	5	1	0,67	✓	IMH901-035-124-HB32-Z5R-SD_06	31146636



Screw-in milling cutter

Dimensions				z _{eff}	a _p max.	SW	Weight [kg]	Internal cooling	Specification	Order no.
d ₁	M	d ₃	l ₁							
16	8	13,8	31	2	1	12	0,03	✓	IMH901-016-M008-Z02R-SD_06	31146646
20	10	18	29,8	3	1	16	0,05	✓	IMH901-020-M010-Z03R-SD_06	31146647
25	12	21	32	4	1	18	0,09	✓	IMH901-025-M012-Z04R-SD_06	31146648
32	16	29	43	5	1	24	0,21	✓	IMH901-032-M016-Z05R-SD_06	31146649
35	16	29	43	5	1	24	0,23	✓	IMH901-035-M016-Z05R-SD_06	31146650

Accessories

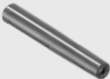
	SD__06	Indexable insert HFC	Page 304
		Chuck for end milling cutter	Page 446
		MFS milling head holder for screw-in milling cutter	Page 446

Spare parts*

	SD__06	Clamping screw for indexable insert M2.2X5.2-TX7-IP	Order no.
			31161853

CAM programming note

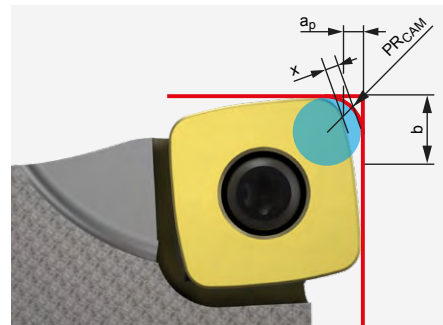

When using an HFC indexable insert, the programme radius PR_{CAM} must be observed.

SD__06

Dimensions [mm]			
PR_{CAM}	a_p	x	b
1,77	1,0	0,45	5,12

Dimensions in mm.

The maximum operating speeds refer only to the cutting edge system.

* Included in scope of delivery.

Depending on the clamping device used, different maximum operating speeds must be observed.

NeoMill®-4-HiFeed90

High-feed and 90° shoulder milling cutter
SD_10

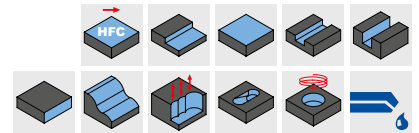
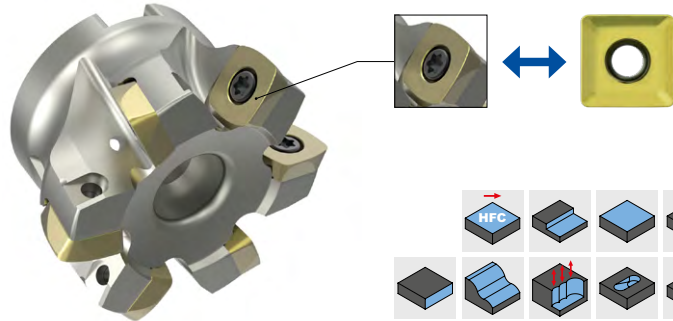
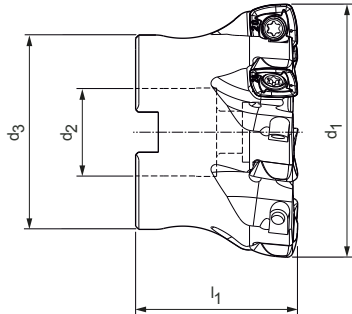

Milling cutter

Dimensions				Z _{eff}	a _p max.		Weight [kg]	Internal cooling	Specification	Order no.
d ₁	d ₂	d ₃	l ₁		90°	HFC				
40	16	35	40	4	9	1,5	0,17	✓	IMH901-040-CA16-Z04R-SD_10	31144056
40	16	35	40	6	9	1,5	0,17	✓	IMH901-040-CA16-Z06R-SD_10	31144057
50	22	43	40	5	9	1,5	0,26	✓	IMH901-050-CA22-Z05R-SD_10	31144059
50	22	43	40	7	9	1,5	0,25	✓	IMH901-050-CA22-Z07R-SD_10	31144060
52	22	43	40	5	9	1,5	0,3	✓	IMH901-052-CA22-Z05R-SD_10	31144061
63	22	48	40	6	9	1,5	0,42	✓	IMH901-063-CA22-Z06R-SD_10	31144062
63	22	48	40	8	9	1,5	0,42	✓	IMH901-063-CA22-Z08R-SD_10	31144063
66	22	48	40	5	9	1,5	0,46	✓	IMH901-066-CA22-Z05R-SD_10	31144085
80	27	60	50	8	9	1,5	0,91	✓	IMH901-080-CA27-Z08R-SD_10	31144064

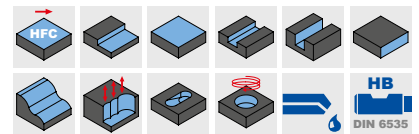
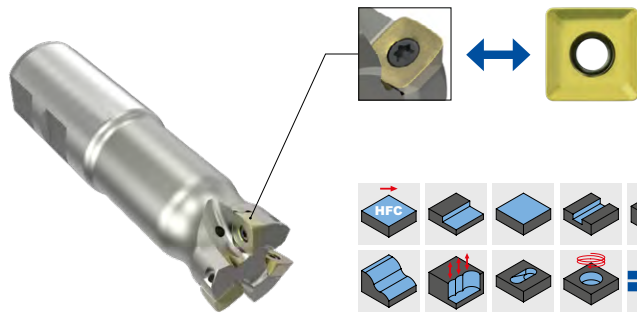
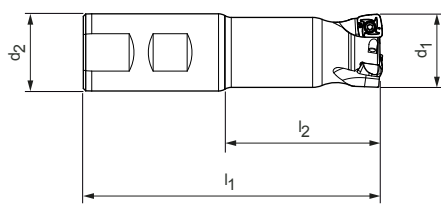

End milling cutter

Dimensions				Z _{eff}	a _p max.		Weight [kg]	Internal cooling	Specification	Order no.
d ₁	d ₂	l ₁	l ₂		90°	HFC				
25	25	106	50	2	9	1,5	0,31	✓	IMH901-025-106-HB25-Z2R-SD_10	31144156
25	25	106	50	3	9	1,5	0,3	✓	IMH901-025-106-HB25-Z3R-SD_10	31144157
32	32	124	64	3	9	1,5	0,64	✓	IMH901-032-124-HB32-Z3R-SD_10	31144158

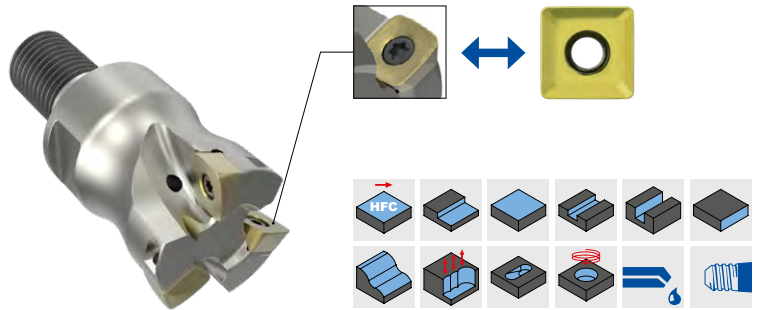
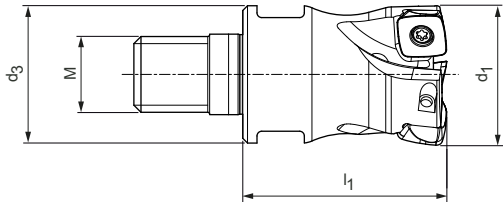

Screw-in milling cutter

Dimensions				Z _{eff}	a _p max.		SW	Weight [kg]	Internal cooling	Specification	Order no.
d ₁	M	d ₃	l ₁		90°	HFC					
25	12	21	32	2	9	1,5	18	0,08	✓	IMH901-025-M012-Z02R-SD__10	31144200
25	12	21	32	3	9	1,5	18	0,07	✓	IMH901-025-M012-Z03R-SD__10	31144201
32	16	29	42	3	9	1,5	24	0,2	✓	IMH901-032-M016-Z03R-SD__10	31144206
32	16	29	43	4	9	1,5	24	0,17	✓	IMH901-032-M016-Z04R-SD__10	31144202
40	16	29	43	4	9	1,5	24	0,21	✓	IMH901-040-M016-Z04R-SD__10	31144203

Accessories

	SD__10	Indexable insert 90°	Page 302
	SD__10	Indexable insert HFC	Page 304
		Milling cutter arbor	Page 446
		Milling cutter clamping screws	Page 312
		Chuck for end milling cutter	Page 446
		MFS milling head holder for screw-in milling cutter	Page 446

CAM programming note

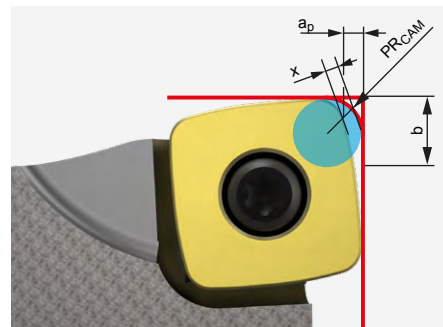

When using an HFC indexable insert, the programme radius PR_{CAM} must be observed.

SD__10

Dimensions [mm]			
PR _{CAM}	a _p	x	b
2,25	1,5	0,62	8,033

Spare parts*

	SD__10	Clamping screw for indexable insert M3X8.3-TX9-IP	Order no. 31161852
--	--------	---	-----------------------

Dimensions in mm.
The maximum operating speeds refer only to the cutting edge system.
* Included in scope of delivery.

Depending on the clamping device used, different maximum operating speeds must be observed.

NeoMill®-4-HiFeed90

High-feed and 90° shoulder milling cutter
SD__14

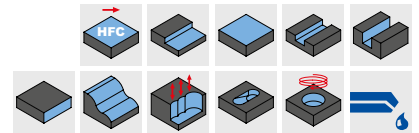
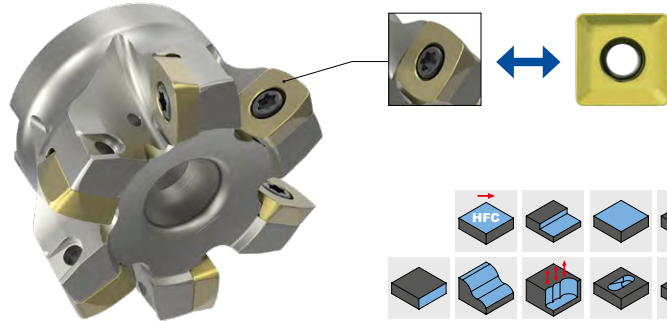
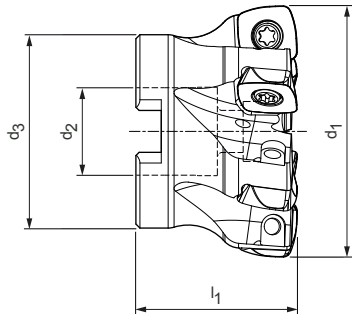

Milling cutter

Dimensions				Z _{eff}	a _p max.		Weight [kg]	Internal cooling	Specification	Order no.
d ₁	d ₂	d ₃	l ₁		90°	HFC				
50	22	43	40	5	12,5	2,4	0,22	✓	IMH901-050-CA22-Z05R-SD__14	31144065
52	22	43	40	5	12,5	2,4	0,28	✓	IMH901-052-CA22-Z05R-SD__14	31144067
63	22	48	40	6	12,5	2,4	0,38	✓	IMH901-063-CA22-Z06R-SD__14	31144068
66	22	48	40	6	12	2,5	0,43	✓	IMH901-066-CA22-Z06R-SD__14	31144069
80	27	60	50	7	12,5	2,4	0,85	✓	IMH901-080-CA27-Z07R-SD__14	31144070
100	32	78	50	7	12,5	2,4	1,49	✓	IMH901-100-CA32-Z07R-SD__14	31144071
100	32	78	50	9	12,5	2,4	1,49	✓	IMH901-100-CA32-Z09R-SD__14	31144072
125	40	90	60	11	12,5	2,4	2,79	✓	IMH901-125-CA40-Z11R-SD__14	31144073

Accessories

	SD__14	Indexable insert 90°	Page 302
	SD__14	Indexable insert HFC	Page 304
		Milling cutter arbor	Page 446
		Milling cutter clamping screws	Page 312

Spare parts*

	SD__14	Clamping screw for indexable insert M5X10.8-TX20-IP	Order no. 31161851
--	--------	---	-----------------------

CAM programming note

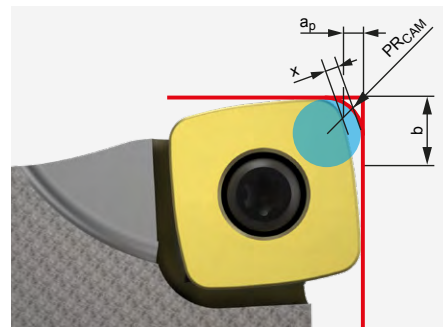

When using an HFC indexable insert, the programme radius PR_{CAM} must be observed.

SD__14

Dimensions [mm]			
PR _{CAM}	a _p	x	b
3,45	2,4	0,93	10,868

Dimensions in mm.

The maximum operating speeds refer only to the cutting edge system.

* Included in scope of delivery.

Depending on the clamping device used, different maximum operating speeds must be observed.

NeoMill®-4-HiFeed90

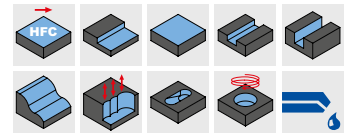
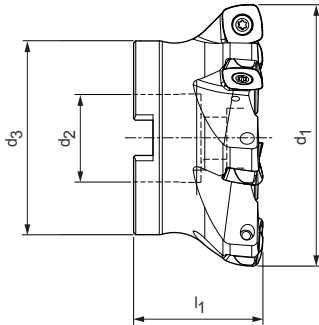

High-feed milling cutter
SD__18



Milling cutter

Dimensions				Z_{eff}	a_p max.	Weight [kg]	Internal cooling	Specification	Order no.
d_1	d_2	d_3	l_1						
80	27	60	50	5	3,5	0,79	✓	IMH901-080-CA27-Z05R-SD__18	31144075
100	32	78	50	6	3,5	1,49	✓	IMH901-100-CA32-Z06R-SD__18	31144087
125	40	90	60	7	3,5	2,43	✓	IMH901-125-CA40-Z07R-SD__18	31144088
160	40	115	60	9	3,5	4,09	-	IMH900-160-CA40-Z09R-SD__18	31144089
200	60	140	65	11	3,5	5,83	-	IMH900-200-CA60-Z11R-SD__18	31144090

Accessories

	SD__18	Indexable insert HFC	Page 304
		Milling cutter arbor	Page 446
		Milling cutter clamping screws	Page 312

Spare parts*

	SD__18	Clamping screw for indexable insert M6X15-T25	Order no. 31161862
---	--------	---	-----------------------

CAM programming note

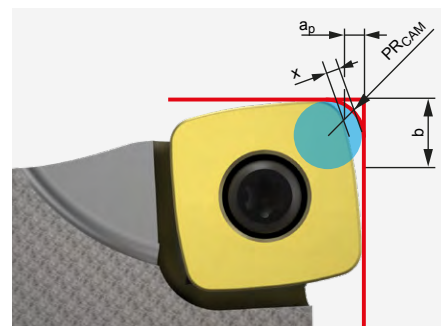

When using an HFC indexable insert, the programme radius PR_{CAM} must be observed.

SD__18

Dimensions [mm]			
PR_{CAM}	a_p	x	b
4,82	3,5	1,24	13,77

Dimensions in mm.

The maximum operating speeds refer only to the cutting edge system.

* Included in scope of delivery.

Depending on the clamping device used, different maximum operating speeds must be observed.

LPMX – LDGX – LDMX – LDHX

Radial indexable insert, double edge, for 90° machining



For 90° machining

		Carbide					
Workpiece material	P						
	Unalloyed					Alloyed	
Coating		PVD					
Cutting material type		HP635		HP640		HP645	
Cutting edge design		PMU		PMU			
LPMX	a_p max. [mm]						
LPMX060204R-	5.2 *	31146697		31146698			
Cutting edge design							
LDGX	a_p max. [mm]						
LDGX180508R-	17 *						
Cutting edge design		PMU	PRU	PMU	PRU	PMU	PRU
LDMX	a_p max. [mm]						
LDMX100404R-	9 *	31146722		31146724			
LDMX100408R-	9 *	31144258		31144259		31144260	
LDMX100420R-	9 *	31144269		31144270			
LDMX100430R-	9 *	31144271		31144272			
LDMX180508R-	17 *	31144276		31144277		31144278	
LDMX180512R-	17 *			31144280		31144281	
LDMX180516R-	17 *			31146720		31146719	
Cutting edge design							
LDHX	a_p max. [mm]						
LDHX100404R-	9 *						
LDHX100408R-	9 *						

Feed per tooth (selection according to chip guiding stage)

* MMG	Chip guiding stage	LP_06			LD_10			LD_18											
		a _p max. [mm]			f _z [mm/tooth]			a _p max. [mm]			f _z [mm/tooth]								
P	PMU	0.5	2	5.2	0.1	0.13	0.17	1	3	9	0.1	0.18	0.25	1	6	17	0.1	0.19	0.25
	PRU													1	6	17	0.15	0.22	0.8
M	MMU	0.5	2	5.2	0.8	0.1	0.15	1	3	9	0.1	0.15	0.2	1	6	17	0.1	0.15	0.22
K	KMU							1	3	9	0.15	0.2	0.27	1	6	17	0.15	0.21	0.26
	KRU													1	6	17	0.15	0.24	0.3
N	NMU							1	3	9	0.1	0.14	0.26	1	6	17	0.1	0.14	0.26

* a_p max. depends on the type of milling cutter and application.

** MAPAL machining groups

Carbide					
M		K		N	
Austenitic ← Wear-resistant		Ferritic → Toughened			
PVD		PVD		Uncoated	PVD
HP650	HP655	HP630		HU110	HP110
MMU					
31146699					
				NMU	NMU
				31144411	31144254
	MMU	MMU	KMU	KRU	
31146690	31146691				
31144256	31144257	31144255			
31144274	31144275	31144273			
31146715	31146717		31144279		
31146716	31146718				
				NMU	NMU
				31144409	31144252
				31144410	31144253

Dimensions [mm]				
l	d	s	d ₁	R
6	3,64	2,15	2,05	0,4
18	9,65	5	4,15	0,8
10	6,6	4,76	2,8	0,4
10	6,6	4,76	2,8	0,8
10	6,6	4,76	2,8	2
10	6,6	4,76	2,8	3
18	9,65	5	4,15	0,8
18	9,65	5	4,15	1,2
18	9,65	5	4,15	1,6
10	6,6	4,76	2,8	0,4
10	6,6	4,76	2,8	0,8

Plunge angle | 90° machining

Diameter [mm]	Plunge angle [°]		
	LP_06	LD_10	LD_18
10	8.4	-	-
12	6.3	-	-
16	5	18	-
18	3.5	-	-
20	2.3	12.2	-
25	1.8	8.7	-
32	1.3	6.2	-
40	1	4.6	5
50	0.8	3.5	4
52	-	-	3.8
63	-	2.7	3.18
66	-	-	2.9
80	-	2.1	2.51
100	-	-	2
125	-	-	1.6
160	-	-	1.25

LPMX – LDMX

Radial indexable insert, double edge, for high-feed machining



For high-feed machining

	Carbide					
Workpiece material	P		M			
	Unalloyed ← Wear-resistant	Alloyed → Toughened	Unalloyed ← Wear-resistant	Alloyed → Toughened	Austenitic ← Wear-resistant	Ferritic → Toughened
Coating	CVD		PVD		PVD	
Cutting material type	HC530	HC535	HP635	HP640	HP650	HP655
Cutting edge design	PMS		PMS	PMS	MMS	MMS
LPMX	a_p max. [mm]					
LPMX060210R-	0.7 *	31146692	31146693		31146694	
Cutting edge design	PMS	PMS	PMS	PMS	MMS	MMS
LDMX	a_p max. [mm]					
LDMX100415R-	1.4 *	31144265	31144266	31144267	31144268	31144263 31144264

Feed per tooth (selection according to chip guiding stage)

* MMG	Chip guiding stage	LP_06						LD_10					
		a_p max. [mm]			f_z [mm/tooth]			a_p max. [mm]			f_z [mm/tooth]		
P	PMS	0.2	0.4	0.7	0.2	0.5	0.8	0.4	0.9	1.4	0.6	1	1.5
M	MMS	0.2	0.4	0.7	0.2	0.4	0.7	0.4	0.9	1.4	0.5	0.9	1.3
K	KMS							0.4	0.9	1.4	0.6	1.2	1.5
H	HMS	0.4	0.4	0.7	0.2	0.5	0.8	0.4	0.9	1.4	0.6	1.2	1.5

* a_p max. depends on the type of milling cutter and application.

** MAPAL machining groups

Carbide			
K			H
CVD	PVD	CVD	PVD
HC525	HP630	HC220	HP320
		HMS	HMS
		31146695	31146696
KMS	KMS	HMS	HMS
31144261	31144262	31146723	31146721

Dimensions [mm]				
l	d	s	d ₁	R
0,7	3,64	2,15	2,05	1
1,5	6,6	4,76	2,8	1,5

Plunge angle | High-feed machining

Diameter [mm]	Plunge angle [°]	
	LP_06	LD_10
10	6.3	-
12	4.5	-
16	3.5	8.8
18	3	-
20	1.8	6.1
25	1.5	4.4
32	1.1	3.2
40	0.8	2.4
50	0.6	1.9
63	-	1.4
80	-	1.1

CAM programming note

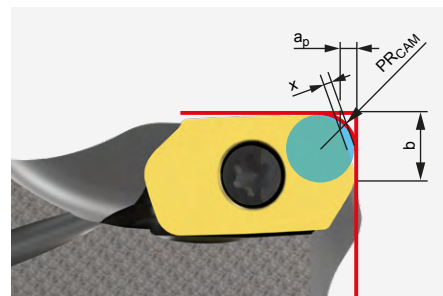

When using an HFC indexable insert, the programme radius PR_{CAM} must be observed.

	Dimensions [mm]			
	PR_{CAM}	a_p	x	b
LP_06	1,2	0,7	0,2	1,4
LD_10	2,2	1,4	0,4	3,52

SDHT – SDMT

Radial indexable insert, with four cutting edges, for 90° machining

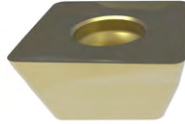

For 90° machining

	Carbide		
Workpiece material	P		
	Unalloyed ← Wear-resistant		Alloyed → Toughened
Coating	PVD		
Cutting material type	HP635	HP640	HP645
Cutting edge design			

SDHT	a_p max. [mm]			
SDHT100404R-	9 *			
SDHT100408R-	9 *			
SDHT140508R-	12.5 *			
SDHT140512R-	12.5 *			

Cutting edge design		PMU	PMU	PMU
SDMT	a_p max. [mm]			
SDMT100408R-	9 *	31144359	31144360	31144361
SDMT140512R-	12.5 *	31144372	31144373	31144374

Feed per tooth (selection according to chip guiding stage)

* MMG	Chip guiding stage	SD_10						SD_14					
		a_p max. [mm]			f_z [mm/tooth]			a_p max. [mm]			f_z [mm/tooth]		
P	PMU	0.8	3	9	0.1	0.18	0.23	1.2	6	12.5	0.1	0.2	0.25
M	MMU	0.8	3	9	0.08	0.14	0.2	1.2	6	12.5	0.1	0.15	0.22
K	KMU	0.8	3	9	0.1	0.2	0.26	1.2	6	12.5	0.1	0.22	0.28
N	NMU	0.8	5	9	0.05	0.12	0.2	1.2	8	12.5	0.06	0.14	0.22

* a_p max. depends on the type of milling cutter and application.

** MAPAL machining groups

Carbide				
M		K	N	
Austenitic ← Wear-resistant		Ferritic → Toughened		
PVD		PVD	Uncoated	PVD
HP650	HP655	HP630	HU110	HP110
			NMU	NMU

Dimensions [mm]				
l	d	s	d ₁	R

			31144412	31144349
			31144413	31144350
			31144414	31144351
			31144415	31144352

10,4	10,4	4,86	3,5	0,4
10,4	10,4	4,86	3,5	0,8
14,8	14,8	5,2	5,5	0,8
14,8	14,8	5,2	5,5	1,2

MMU	MMU	KMU		
31144357	31144358	31144356		
31144370	31144371	31144369		

10,4	10,4	4,86	3,5	0,8
14,8	14,8	5,2	5,5	1,2

Plunge angle | 90° machining

Diameter [mm]	Plunge angle [°]	
	SD__10	SD__14
25	7	-
32	4.6	-
40	3.3	-
50	2.4	5.5
52	2.2	5.3
63	1.8	3.7
66	1.6	3.4
80	1.3	2.6
100	1	1.9
125	0.8	1.5
160	0.5	-

SDMT – SDMW

Radial indexable insert, with four cutting edges, for high-feed machining

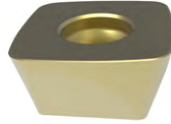

For high-feed machining

	Carbide				
Workpiece material	P				
	Unalloyed ← Wear-resistant	Alloyed → Toughened		Unalloyed ← Wear-resistant	Alloyed → Toughened
Coating	CVD			PVD	
Cutting material type	HC530	HC535	HP635	HP640	HP645
Cutting edge design	PMS	PMS	PMS	PMS	

SDMT

a_p max. [mm]

SDMT060212R-	1 *			31144355		
SDMT100415R-	1.5 *	31144365	31144366	31144367	31144368	
SDMT140520R-	2.4 *	31144378	31144379	31144380	31144381	
SDMT180630R-	3.5 *			31144384	31144385	

Cutting edge design

PRS

PRS

PRS

PRS

PRS

SDMW

a_p max. [mm]

SDMW100415R-	1.5 *	31144391	31144392	31144393	31144394	
SDMW140520R-	2.4 *	31144400	31144401	31144402	31144403	
SDMW180630R-	3.5 *				31144407	31144408

Feed per tooth (selection according to chip guiding stage) and plunge angle

* MMG	Chip guiding stage	SD_06			SD_10			SD_14			SD_18		
		a_p max. [mm]	f_z [mm/tooth]		a_p max. [mm]	f_z [mm/tooth]		a_p max. [mm]	f_z [mm/tooth]		a_p max. [mm]	f_z [mm/tooth]	
P	PMS	0.3 0.5 1	0.4 0.6 1.1		0.5 0.8 1.3	0.6 1 1.4		0.6 1.2 2.2	0.7 1.4 2.2		1 2.2 3.2	1.2 1.8 2.8	
	PRS				0.5 1 1.5	0.7 1.1 1.6		0.7 1.5 2.4	0.8 1.6 2.4		1 2.5 3.5	1.4 2.2 3	
M	MMS	0.3 0.5 1	0.3 0.5 1		0.5 0.8 1.3	0.5 0.9 1.4		0.6 1.2 2.2	0.8 1.2 2.2		1 2 3	1 1.6 2.5	
K	KRS				0.5 1 1.5	0.7 1.2 1.6		0.7 1.6 2.4	0.8 1.7 2.4		1 2.8 3.5	1.4 2.5 3	
H	HMS	0.3 0.5 1	0.4 0.6 1.1					0.4 1.2 2.2	0.4 1.2 2.2				
	HRS				0.4 0.8 1.2	0.4 1.1 1.6		0.5 1.5 2.4	0.5 1.6 2.4		1 2.2 3.5	0.8 1.8 2.8	

* a_p max. depends on the type of milling cutter and application.

** MAPAL machining groups

Carbide							
M		K		H			
Austenitic		Ferritic				≥ 65 HRC	
← Wear-resistant		→ Toughened				← Wear-resistant	
PVD		CVD		PVD		CVD	
HP650	HP655	HC525	HP630	HC220	HP320	HP325	
MMS	MMS				HMS	HMS	

Dimensions [mm]				
l	d	s	d ₁	R

31144354					31144353	
31144363	31144364				31144362	31146714
31144376	31144377				31144375	
31144382	31144383					

1	6,75	2,5	2,5	1,2
1,1	10,2	4,86	3,5	1,5
2,2	14,7	5	5,5	2
3	18,7	6	6,5	3

		KRS	KRS	HRS	HRS	HRS
		31144389	31144390	31144386	31144387	31144388
		31144398	31144399	31144395	31144396	31144397
		31144405	31144406			31144404

1,1	10,2	4,86	3,5	1,5
2,2	14,7	5	5,5	2
3	18,7	6	6,5	3

CAM programming note

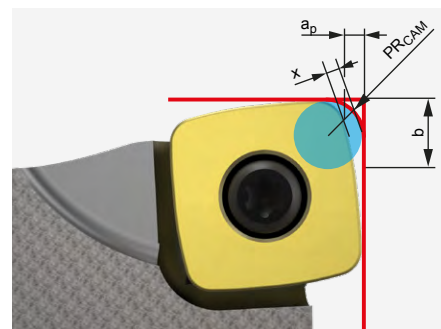

When using an HFC indexable insert, the programme radius PR_{CAM} must be observed.

Plunge angle | High-feed machining

Diameter [mm]	Plunge angle [°]			
	SDM_06	SDM_10	SDM_14	SDM_18
16	9	-	-	-
20	4.8	-	-	-
25	3	4.4	-	-
32	2	2.9	-	-
35	1.7	-	-	-
40	-	2	-	-
50	-	1.5	2.4	-
52	-	1.3	2.2	-
63	-	1.1	1.7	-
66	-	1	1.5	-
80	-	0.8	1.3	2.5
100	-	0.7	1	2
125	-	0.5	0.7	1.6
160	-	-	-	1.3
200	-	-	-	1

Dimensions [mm]				
	PR_{CAM}	a_p	x	b
SD_06	1,77	1,0	0,45	5,12
SD_10	2,25	1,5	0,62	8,033
SD_14	3,45	2,4	0,93	10,868
SD_18	4,82	3,5	1,24	13,77

Cutting data recommendations for milling cutter with indexable inserts

Cutting speed (selection according to cutting material type and contact ratio a_e/D)

IMH90-L2, IMH90-S4

MMG*		Workpiece material	Strength/ hardness [N/mm ²] [HRC]	Cooling			Cutting material type according to contact ratio a_e/D													
				MQL/Air	Dry	Wet	Carbide uncoated		Carbide PVD-coated											
							HU110		HP110		HP310		HP315							
							>0.6	<0.6	>0.6	<0.6	>0.6	<0.6	>0.6	<0.6						
P	P1	P1.1	Structural, machining, case hardened and tempering steels, unalloyed	< 700		✓														
		P1.2	Structural, machining, case hardened and tempering steels, unalloyed	< 1,200		✓														
	P2	P2.1	Nitriding, hardening and tempering steels, alloyed	< 900		✓														
		P2.2	Nitriding, hardening and tempering steels, alloyed	< 1,400		✓														
	P3	P3.1	Tool, bearing, spring and high-speed steels**	< 800		✓														
		P3.2	Tool, bearing, spring and high-speed steels**	< 1,000		✓														
		P3.3	Tool, bearing, spring and high-speed steels**	< 1,500		✓														
	P4	P4.1	Stainless steels, ferritic and martensitic																	
	P5	P5.1	Cast steel																	
P6	P6.1	Stainless cast steels, ferritic and martensitic																		
M	M1	M1.1	Stainless steels, austenitic	< 700		✓														
		M1.2	Stainless steels, ferritic/austenitic (duplex)	< 1,000																
	M2	M2.1	Stainless cast steel, austenitic	< 700																
		M3.1	Stainless cast steel, ferritic/austenitic (duplex)	< 1,000																
K	K1	K1.1	Cast iron with lamellar graphite (grey cast iron), GJL	< 300		✓														
		K2.1	Cast iron with spheroidal graphite, GJS	< 500		✓														
	K2	K2.2	Cast iron with spheroidal graphite, GJS	≤ 800																
		K2.3	Cast iron with spheroidal graphite, GJS	> 800																
		K3.1	Cast iron with vermicular graphite, GJV; malleable cast iron, GJM	< 500																
	K3.2	Cast iron with vermicular graphite, GJV; malleable cast iron, GJM	> 500																	
N	N1	N1.1	Aluminium, unalloyed and alloyed < 3 % Si			✓	400	2,500	500	3,000										
		N1.2	Aluminium, alloyed ≤ 7% Si				300	400	400	500										
		N1.3	Aluminium, alloyed > 7 - 12% Si				300	400	400	500										
		N1.4	Aluminium, alloyed > 12% Si				300	400	400	500										
	N2	N2.1	Copper, unalloyed and low alloyed	< 300		✓	120	400	160	500										
		N2.2	Copper, alloyed	> 300			160	250	200	300										
		N2.3	Brass, bronze, gunmetal	< 1,200			160	250	200	300										
H	H1	H1.1	Hardened steel / cast steel	< 44 HRC		✓														
		H1.2	Hardened steel / cast steel	< 55 HRC		✓														
	H2	H2.1	Hardened steel / cast steel	< 60 HRC		✓														
		H2.2	Hardened steel / cast steel	< 65 HRC		✓														
		H2.3	Hardened steel / cast steel	< 68 HRC		✓														
	H3	H3.1	Wear-resistant cast/chill casting, GJN			✓														

* MAPAL machining groups

** If the alloy parts Cr, Mo, Ni, V, W in total > 8%, then select the next highest MAPAL machining group.



FINISHING MILLING CUTTERS

NeoMill-3D-Finish

Screw-in milling cutter 310

Radial indexable insert

CDGX 311

Accessories and spare parts

Spare part for radial indexable inserts 313

Technical appendix

Cutting data recommendations 311

NeoMill®-3D-Finish

Finishing milling cutter, contact angle 95°
CDGX06





Screw-in milling cutter

Dimensions				Z _{eff}	a _p max.		SW	Weight [kg]	Internal cooling	Specification	Order no.
d ₁ *	M	d ₃	l ₁		Universal	Wiper					
16	8	12,7	23	2	1	1,8	10	0,02	✓	IMF951-016-M008-Z02R-CD_X06	31144219
16	10	15,4	23	2	1	1,8	15	0,03	✓	IMF951-016-M010-Z02R-CD_X06	31144220
20	10	17,7	30	3	1	1,8	15	0,05	✓	IMF951-020-M010-Z03R-CD_X06	31144221
25	12	20,7	35	3	1	1,8	17	0,09	✓	IMF951-025-M012-Z03R-CD_X06	31144222
25	12	20,7	35	4	1	1,8	17	0,09	✓	IMF951-025-M012-Z04R-CD_X06	31144223
35	16	28,7	43	5	1	1,8	24	0,2	✓	IMF951-035-M016-Z05R-CD_X06	31144224
42	16	28,7	43	6	1	1,8	24	0,24	✓	IMF951-042-M016-Z06R-CD_X06	31144225

* In combination with HFW chip guiding stage, the d₁ (cutting circle diameter) is reduced by 0.15 mm.

Accessories

	CDGX0602	Indexable insert	Page 311
		MFS milling head holder	Page 446

Spare parts*

	Clamping screw for indexable insert M2.5X5.5-TX7-IP	Order no. 31164572
---	---	-----------------------

Application note

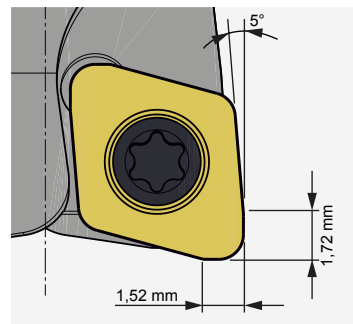

Due to the 95° contact angle of the indexable insert, the relief angle is 5°. When using an indexable insert with wiper geometry, the finish turning parts specified must be observed.

Dimensions in mm.

The maximum operating speeds refer only to the cutting edge system.

* Included in scope of delivery.

Depending on the clamping device used, different maximum operating speeds must be observed.

CDGX

Radial indexable insert, double edge

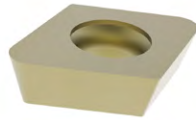

Workpiece material	Carbide			
	H	≥ 65 HRC	60 HRC	58 HRC
Coating	PVD			
Cutting material type	HP310	HP315	HP320	HP325
CDGX		a _p max. [mm]		
CDGX060210R-HFU	1 *	31144226	31144228	31144227
CDGX060210R-HFW	1.8 *	31144250		31144251

Dimensions [mm]				
l	d	s	d ₁	R
5,8	6,5	2,38	2,9	1
5,8	6,5	2,38	2,9	1

Feed per tooth (selection according to chip guiding stage)

* MMG	Chip guiding stage	CD_06					
		a _p max. [mm]			f _z [mm/tooth]		
H	HFU	0.1	0.25	1	0.08	0.22	0.33
	HFW	0.12	0.25	1.8	0.1	0.25	0.4





Cutting speed (selection according to cutting material type and contact ratio a_e/D)

MMG**		Workpiece material	Strength/hardness [N/mm ²] [HRC]	Cooling			Cutting material type according to contact ratio a _e /D							
				MQL/Air	Dry	Wet	Carbide PVD-coated							
							HP310		HP315		HP320		HP325	
H	H1	H1.1	Hardened steel / cast steel	< 44 HRC		✓	90	290	90	290	80	270	90	180
		H1.2	Hardened steel / cast steel	< 55 HRC		✓	70	230	70	230	60	210	60	170
	H2	H2.1	Hardened steel / cast steel	< 60 HRC		✓	60	190	60	190	50	170	50	130
		H2.2	Hardened steel / cast steel	< 65 HRC		✓	50	140	50	140	40	120		
		H2.3	Hardened steel / cast steel	< 68 HRC		✓								
	H3	H3.1	Wear-resistant cast/chill casting, GJN			✓	60	140	60	140	50	120		

* a_p max. depends on the type of milling cutter and application.

** MAPAL machining groups

Allocating milling cutter clamping screws for milling cutters with indexable inserts

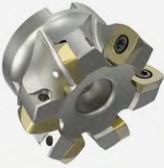
Series	Diameter of milling cutter	Diameter of milling cutter arbor	Milling cutter clamping screw		
			 Cylinder screw *	 Cross-headed screw **	
IMR00-R 	RD..	40 - 42	16	10003639	
		48 - 52	22	10003660	
		63 - 80	27	10003677	
		100	32	10003690	
		125	40	10111521	
		160	40	10006594 (x4)	10004066
IMH90-L2 	LP_06	32	16	10003638	
		40	16	10003638	
		50	22	10003659	
	LD_10	40	16	10003637	
		50 - 63	22	10003659	
		80	27	10003677	
	LD_18	40	16	10003638	
		50 - 66	22	10003659	
		80	27	10003677	
		100	32	10006565	
		125	40	10009106	
		160	40	10006594 (x4)	10004066
IMH90-S4 	SD_10	40	16	31166231	
		50 - 66	22	10003659	
		80	27	10003677	
	SD_14	50 - 52	22	31166232	
		63 - 66	22	10003659	
		80	27	10003677	
		100	32	10003690	
		125	40	10081881	
	SD_18	80	27	10003677	
		100	32	10003690	
		125	40	10081881	
		160	40	10006594 (x4)	10004066
200		60	10006594 (x4)		

Dimensions in mm.

* Included in scope of delivery for the tool body.

** Optional for clamping via central control.

Spare parts for radial indexable inserts

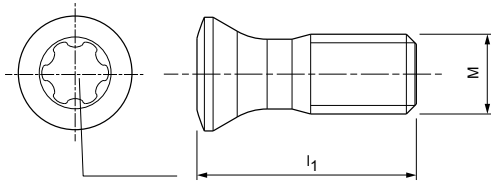

Spare parts for radial indexable inserts

Indexable insert	Size of indexable insert	Clamping screw/clamping plate					Screwdriver
		Dimension	Description	Tightening torque [Nm]	Torx size	Order no.	Order no.
BM/TM	08	M2.5X6.25	TORX PLUS® - M2.5X6.25-TX7-IP	1,4 Nm	7IP	31161844	30414759
	10	M3X7.7	TORX PLUS® - M3X7.7-TX8-IP	2,5 Nm	8IP	31161845	30414760
	12	M3.5X9.5	TORX PLUS® - M3.5X9.5-TX10-IP	3,5 Nm	10IP	31161846	30414763
	16	M4X13.3	TORX PLUS® - M4X13.3-TX15-IP	5 Nm	15IP	31161847	30414764
	20	M5X16.2	TORX PLUS® - M5X16.2-TX20-IP	7 Nm	20IP	31161848	30414766
	25	M6X20	TORX PLUS® - M6X20-TX25-IP	8 Nm	25IP	31161849	30414767
	32	M8X25	TORX PLUS® - M8X25-TX40-IP	20 Nm	40IP	31161850	10075488
RD	05	M1.8X3.7	TORX PLUS® - M1.8X3.7-TX6-IP	0,6 Nm	6IP	31161858	30414758
	07	M2.5X5.5	TORX PLUS® - M2.5X5.5-TX7-IP	1,4 Nm	7IP	31161854	30414759
	12	M3.5X7.2	TORX PLUS® - M3.5X7.2-TX15-IP	3,5 Nm	15IP	31161859	30414764
		M3.5X8.6	TORX PLUS® - M3.5X8.6-TX15-IP	3,5 Nm	15IP	31161860	30414764
	16	M3.5X7.2	TORX PLUS® - M3.50X7.2-TX15-IP	5 Nm	15IP	31161928	30414764
		M4.5X10.5	TORX PLUS® - M4.5X10.5-TX20-IP	5,5 Nm	20IP	31161861	30414766
		Clamping plate				31161929	
LP	06	M1.8X4.09	TORX PLUS® - M1.8X4.09-TX6-IP	0,9 Nm	6IP	31164571	30414758
LD	10	M2.5X5.9	TORX PLUS® - M2.5X5.9-TX8-IP	1,5 Nm	8IP	31161842	30414760
	10	M2.5X6.8	TORX PLUS® - M2.5X6.8-TX8-IP	2 Nm	8IP	31161843	30414760
	18	M3.5X10	TORX PLUS® - M3.5X10-TX15-IP	3,5 Nm	15IP	30870699	30414764
SD	06	M2.2X5.2	TORX PLUS® - M2.2X5.2-TX7-IP	1,2 Nm	7IP	31161853	30414759
	10	M3X8.3	TORX PLUS® - M3X8.3-TX9-IP	2 Nm	9IP	31161852	30414761
	14	M5X10.8	TORX PLUS® - M5X10.8-TX20-IP	5 Nm	20IP	31161851	30414766
	18	M6X15	TORX® - M6X15-T25	6 Nm	T25	31161862	10019476
CD	06	M2.5X5.5	TORX PLUS® - M2.5X5.5-TX7-IP	1,2 Nm	7IP	31164572	30414759

Accessories – mounting aids

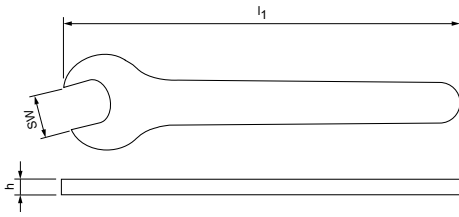

Assembly tool

Connection size CFS	Dimensions			Order no.
	SW	l_1	h	
6	6	75	2,3	30352660
8	8	92	2,8	30352661
10	10	100	3,8	30352662
15	15	145	4,8	30352666
16	16	145	4,8	30352667
24	24	215	4,8	30352669

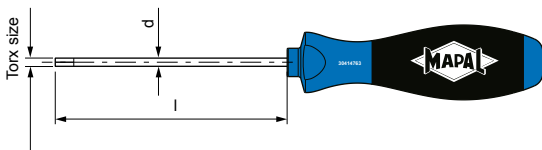

Screwdriver

Torx size	Dimensions		Name	Order no.
	l	d		
6IP	60	3,5	TORX PLUS®	30414758
7IP	60	3,5		30414759
8IP	60	3,5		30414760
9IP	60	4		30414761
10IP	80	4		30414763
15IP	80	4		30414764
20IP	100	4		30414766
25IP	100	4,5		30414767
TX8	60	3,5		TORX®
TX15	80	4	10019469	

General accessories – torque wrench set

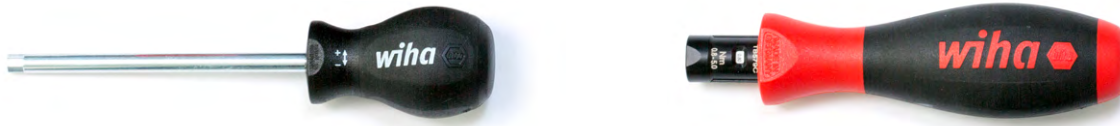

TorqueVario®-S torque screwdriver set

Area	Scope of delivery	Features	Order no.
1.0 – 5.0 Nm	<ul style="list-style-type: none"> • 1 TorqueVario-S torque screwdriver • 1 torque setter 	<ul style="list-style-type: none"> • Accuracy ± 6% can be traced to national standards • Numeric torque value indication on window scale • Torque continuously adjustable • Ergonomic multiple component handle • Click signal on reaching the set torque 	10103019
2.0 – 8.0 Nm			31363399



TorqueVario®-STplus T-key torque wrench 11 pcs. set

Model: 5–14 Nm

Scope of delivery	Features	Order no.
<ul style="list-style-type: none"> • 1 T-key torque wrench • 1 Torque-Plus Setter • 1 universal bit holder 1/4" • 3 TORX® standard bits T25x25 / T30x25 / T40x25 • 3 hex standard bits 4.0x25 / 5.0x25 / 6.0x25 • 2 adapter bits for the sockets <ul style="list-style-type: none"> 1 Torque-Plus adapter bit 1/4" 1 Torque-Plus adapter bit 3/8" • Stable metal box 	<ul style="list-style-type: none"> • Accuracy ± 6% can be traced to national standards • Numeric torque value indication on window scale • Torque continuously adjustable • Comfortable T-key with soft zones • Click signal on reaching the set torque 	30415173

Torx extension to mount the clamping screw with the torque wrench

	Indexable insert	Torx size	Order no.
	SD__T06	7IP	30237488
	SD__T10	9IP	10102290
	SD__T14	20IP	30237490
	SD__T18	T25	30237491



DRILLING FROM SOLID | COUNTER- SINKING

Double-edged and three-edged solid carbide drills for drilling from solid in steel, hardened steel, stainless steel and cast iron. Deep drills for making deep bores up to 40xD. Precision countersinks with unequal spacing for greater precision and better surfaces.



PRODUCT OVERVIEW

Drilling from solid and countersinking

MAPAL has been intensively involved in the various challenges of drilling operations for decades, and as a result has acquired extensive experience and competence in this area. The productive solid carbide range is suitable for machining almost all materials – cast iron, non-ferrous metals, steels and workpiece materials that are difficult to machine. The standard range includes universal double-edge and triple-edge drills, deep drills up to 40xD, drill reamers, and other drilling tools for specific machining operations. Unequally spaced precision countersinks complete the range.

The MAPAL range of deep drills with internal cooling for machining centres is available from a diameter of 1.0 mm. Thanks to the newly designed chip flute and special face grinding, the highest-possible feed rates and cutting speeds can be achieved when carrying out deep drilling. On top of that, the innovative cooling-channel guide means that the drills are also suitable for use with minimum quantity lubrication.



Basic Line:
Universal tools, broad field of application, low procurement costs



Performance Line:
High-performance tools, broad field of application, high productivity in series production









Expert Line:
Specialist tools for selected applications, maximum precision and productivity

Drilling from solid with solid carbide

 	 	 	 
<p>ECU-Drill-Steel</p> <p>Double edge twist drill with a wide range of applications.</p> <ul style="list-style-type: none"> - Highly economical machining of steel - Universal application - Proven geometries for high precision and process reliability <p>Ø area: 1.00 - 20.00 mm</p> <p>Drilling depth: 5xD 8xD 12xD</p> <p>P K</p>	<p>MEGA-Drill</p> <p>High performance twist drill with two cutting edges for maximum productivity.</p> <ul style="list-style-type: none"> - MEGA-Drill-Steel-Plus – Optimised chip flute geometry and modified cutting edge preparation for steel machining - MEGA-Drill-Hardened – Process-reliable machining of hardened workpiece materials <p>Ø area: 2.55 - 16.00 mm</p> <p>Drilling depth: 3xD 5xD 8xD</p> <p>P M K H</p>	<p>Tritan-Drill</p> <p>Three-edged geometry enables significantly higher feed rates and a significantly longer tool life, even in the case of difficult bore machining tasks.</p> <ul style="list-style-type: none"> - Tritan-Drill-Steel – Specially designed for steel machining - Tritan-Spot-Drill-Steel – NC pilot drills for triple-edge drills <p>Ø area: 4.00 - 20.00 mm</p> <p>Drilling depth: 3xD 5xD 8xD 12xD</p> <p>P M K</p>	<p>MEGA-Deep-Drill-Steel</p> <p>Process-reliable and efficient production of deep bores up to 40xD.</p> <ul style="list-style-type: none"> - MICRO-Step-Drill-Steel – Pilot drill specifically designed for the MEGA-Deep-Drill - MICRO-Drill-Steel – Pilot drill specifically designed for the MEGA-Deep-Drill <p>Ø area: 1.00 - 16.00 mm</p> <p>Drilling depth: 5xD 15xD 20xD 25xD 30xD 40xD</p> <p>P K</p>
<p>Page 330</p>	<p>Page 341</p>	<p>Page 359</p>	<p>Page 376</p>



Drilling from solid with solid carbide	Drilling from solid with a replaceable head system	Countersinking
 	 	 
<p>MEGA and Tritan-Drill-Reamer</p> <p>Two working steps – drilling and reaming – combined in a single tool.</p> <ul style="list-style-type: none"> - MEGA-Drill-Reamer-Pyramid – Good centring properties thanks to pyramid tip - Tritan-Drill-Reamer – Improved tapping behaviour due to three cutting edges for difficult bore machining operations <p>Ø area: 4.00 - 16.00 mm</p> <p>Drilling depth:</p> <p>3xD 5xD</p> <p>P K N</p>	<p>QTD indexable insert drill</p> <p>Cost-effective system with indexable inserts that can be swapped out.</p> <ul style="list-style-type: none"> - Optimally embedded cutting edge - Force-locking and positive form clamping system - Easy to handle - High degree of radial run-out accuracy - Very good chip formation and safe chip removal <p>Ø area: 8.10 - 49.00 mm</p> <p>P K</p>	<p>Precision countersinks with unequal spacing</p> <ul style="list-style-type: none"> - Higher degree of accuracy and improved surface values thanks to extremely unequal cutting edges - Reduced axial and radial forces - Significantly less vibrations - Increased cutting parameters to ensure the highest productivity - Offered in HSS & solid carbide designs <p>Ø area: 4.30 - 31.00 mm</p> <p>P M K N C S H</p>
<p>Page 386</p>	<p>Page 396</p>	<p>Page 402</p>

SELECTING A DRILL

Step-by-step guide to selecting the right drill

Say you're looking for a solid drill to machine hardened steel. This selection guide will show you how to pick the right drill step by step.

- 1

Application

Select the main use for your new drill.

>



Drilling from solid



Step drilling and pilot drilling

- 2

Design

Select your preferred tool design.

>



Monolithic



QTS connection

- 3

Product category

Choose a product category.

>



Basic Line:
Universal tools, wide range of applications, low acquisition costs

- 4

Material suitability

Select your workpiece according to the MAPAL machining groups (MMG). You'll find the MMG chart on the fold-out page at the end of the catalogue.

>

P

Steel

M

Stainless steel

- 5

Part features

Check the demands the bore properties will place on your tool.

>



Drilling from solid



Cross bore

- 6

Design

Check that the geometric features meet your requirements.

>

Diameter range

Number of cutting edges

- 7

Product

Select the drill you need. Products of the preferred series are available from stock and at short notice, while products with configurable features can be freely configured within predefined limits.

>



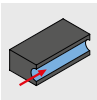

Deep drilling

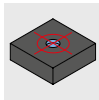

Tapping

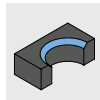

Countersinking



Performance Line:
High-performance tools, broad field of application, high productivity in series production



Expert Line:
Specialist tools for selected applications, maximum precision and productivity



Cast iron



Non-ferrous metals and plastics

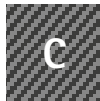

Composite materials



Super alloy and titanium



Hardened steel and cast steel

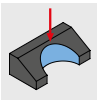

Inclined bore entrance

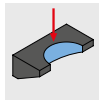

Inclined bore outlet

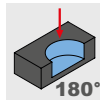

Flat bottom of the bore



Achievable bore tolerance



Maximum drilling depth



Coolant supply



Product with configurable features

Step 1: Application



Step 2: Design



Step 3: Product category



Step 4: Material suitability



Step 5: Part features



Step 6: Design



Design			Product			
ø [mm]	z		Product name	Specification		Page
1 - 20	2	✓	ECU-Drill-Steel	SCD361		330
0,8 - 2,99	2	✓	MICRO-Drill-Steel	SCD371		338
3 - 25	2	✓	MEGA-Drill-Steel-Plus	SCD601		341
2,55 - 16	2	✓	MEGA-Drill-Hardened	SCD140		356
0 - 20	2	✓	MICRO-180° Drill	SCD237		370

6

7



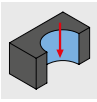

Drilling from solid

Design	Product category	Material suitability							Bore features					Drilling depth					
		P	M	K	N	C	S	H						Tolerance	1.5xD	3xD	5xD	8xD	12xD
	Basic LINE	■	■	■	■	■	■	■	✓					IT9		✓	✓	✓	✓
	Performance LINE	■	■	■	■	■	■	■						IT9			✓	✓	✓
		■	■	■	■	■	■	■	✓					IT9		✓	✓	✓	
		■	■	■	■	■	■	■	✓					IT9		✓			
		■	■	■	■	■	■	■						IT9		✓	✓		
		Expert LINE	■	■	■	■	■	■	■	✓	✓	✓	✓	IT9		✓	✓	✓	✓
		■	■	■	■	■	■	■	✓					IT7			✓		
		■	■	■	■	■	■	■						IT7		✓	✓		
		★	■	■	■	■	■	■	✓					IT10	✓	✓	✓	✓	✓

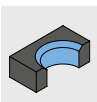

Step drilling and pilot drilling

Design	Product category	Material suitability							Bore features					Drilling depth					
		P	M	K	N	C	S	H						Tolerance	1.5xD	3xD	5xD	8xD	12xD
	Performance LINE	■	■	■	■	■	■	■	✓					IT9					

■ highly suitable

■ suitable in some situations

Step 1:
Application

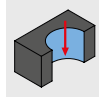

Step 2:
Design



Step 3:
Product category



Step 4:
Material suitability













Step 5:
Part features

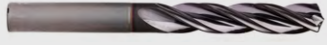

Step 6:
Design



Design				Product		
ø [mm]	z		Product name	Specification		Page
1 - 20	2	✓	ECU-Drill-Steel	SCD361		330
0,8 - 2,99	2	✓	MICRO-Drill-Steel	SCD371		338
3 - 25	2	✓	MEGA-Drill-Steel-Plus	SCD601		341
2,55 - 16	2		MEGA-Drill-Hardened	SCD140		356
3 - 20	2	✓	MEGA-180°-Drill	SCD231		370
4 - 20	3	✓	Tritan-Drill-Steel	SCD661		360
4 - 16	2	✓	MEGA-Drill-Reamer-Pyramid	SDR201		386
3,8 - 20,05	3	✓	Tritan-Drill-Reamer	SDR301		388
8,1 - 49	2	✓	QTD steel indexable inserts	01-Steel		396

Design				Product		
ø [mm]	z		Product name	Specification		Page
1 - 3	2	✓	MICRO-Step-Drill-Steel	SCD581		376

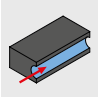

Deep drilling

Design	Product category	Material suitability							Bore features					Drilling depth					
		P	M	K	N	C	S	H					Tolerance	15xD	20xD	25xD	30xD	40xD	
	Performance LINE	■	■	■	■	■	■	■					IT9	✓	✓	✓	✓	✓	
		■	■	■	■	■	■	■					IT9		✓		✓		

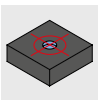

Tapping

Design	Product category	Material suitability							Bore features					Drilling depth					
		P	M	K	N	C	S	H					Tolerance	15xD	20xD	25xD	30xD	40xD	
	Expert LINE	■	■	■	■	■	■	■											

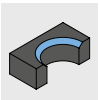

Countersinking

Design	Product category	Material suitability							Bore features					Drilling depth					
		P	M	K	N	C	S	H					Tolerance	15xD	20xD	25xD	30xD	40xD	
	Performance LINE	■	■	■	■	■	■	■											
		■	■	■	■	■	■	■											

Step 1:
Application



Step 2:
Design



Step 3:
Product category



Step 4:
Material suitability







Step 5:
Part features





Step 6:
Design

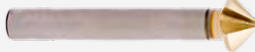

Design				Product		
ø [mm]	z		Product name	Specification		Page
1 - 16	2	✓	MEGA-Deep-Drill-Steel	SCD701		377
1 - 2,90	2	✓	MICRO-Deep-Drill	SCD171		378

Design				Product		
ø [mm]	z		Product name	Specification		Page
4 - 20	3		Tritan-Spot-Drill-Steel	SCD670		359

Design				Product		
ø [mm]	z		Product name	Specification		Page
4,3 - 31	3		Countersink 90°, HSS design	COS110		404
6,3 - 31	3		Countersink 90°, solid carbide design	COS110		405

Product ID codes

Solid carbide drill

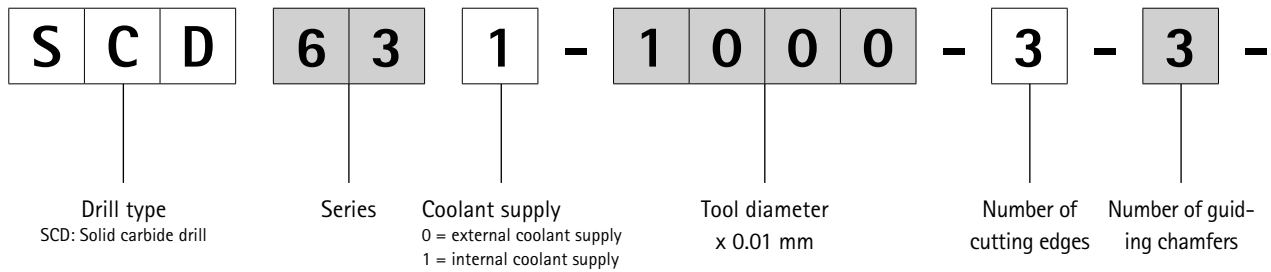

QTD changing system

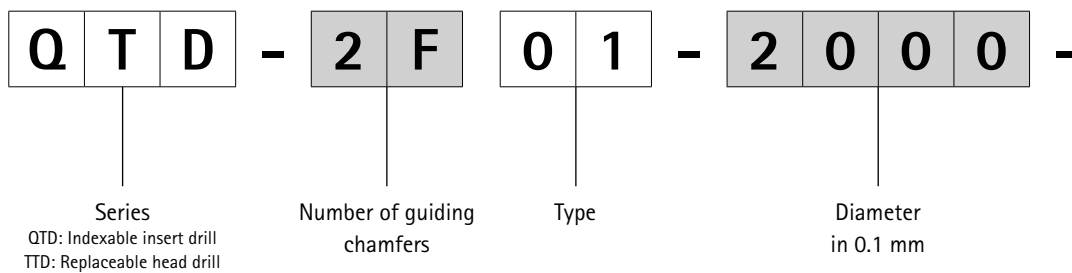

QTS and QTD holder range

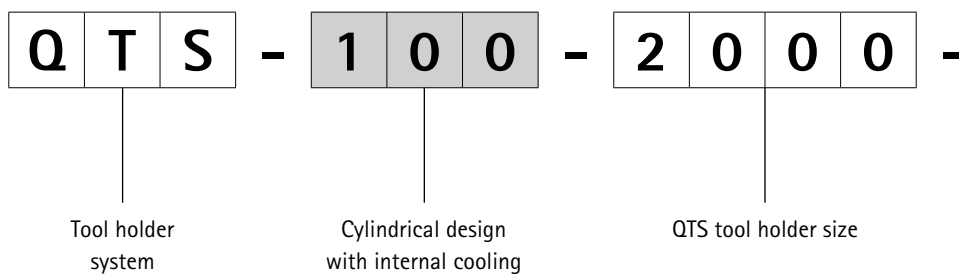

Countersink tools

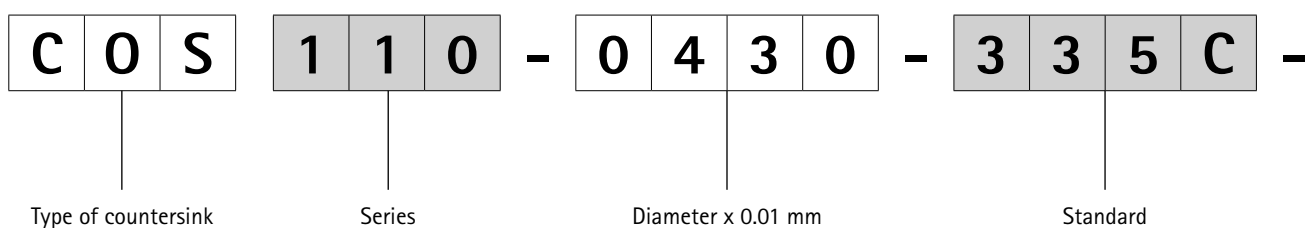

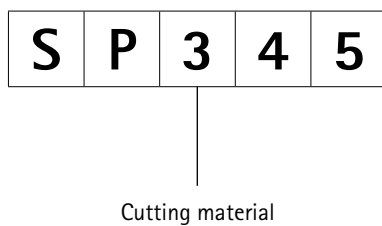
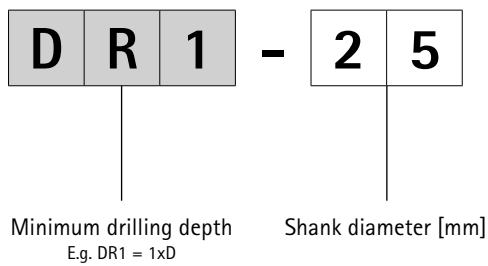
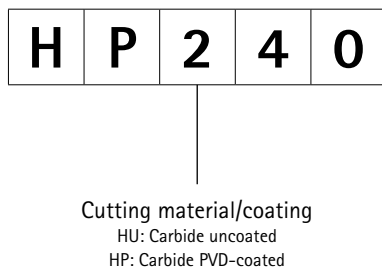
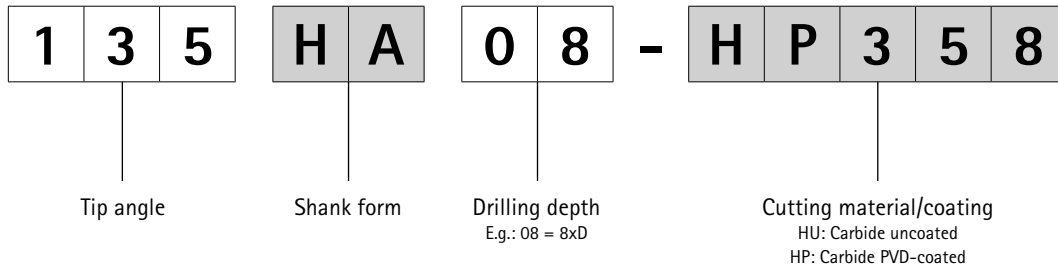



DRILLING FROM SOLID | COUNTERSINKING

Drilling from solid with solid carbide

ECU-Drill-Steel	330
MICRO-Drill-Steel	338
MEGA-Drill-Steel-Plus	341
MEGA-Drill-Hardened	356
Tritan-Spot-Drill-Steel	359
Tritan-Drill-Steel	360
MEGA-180°-Drill	370
MICRO-Step-Drill-Steel	376
MEGA-Deep-Drill-Steel	377
MEGA-Drill-Reamer-Pyramid	386
Tritan-Drill-Reamer	388

Drilling from solid with a replaceable head system

QTD indexable inserts	396
QTS indexable insert holder	398

Countersinking

Introduction to the technology	402
Countersink, HSS design	404
Countersink, solid carbide design	405

Accessories and spare parts

Screwdriver and clamping screw	406
--------------------------------------	-----

Technical appendix

QTD instructions for use	407
Application note for deep drilling	408
Cutting data recommendations	410



ECU-Drill-Steel

Solid carbide twist drill
SCD361 (5xD), internal coolant supply

Design:

Drill diameter: 3.00 - 20.00 mm
Bore tolerance: \geq IT 9
Cutting material: HP132
Number of cutting edges: 2
Tip angle: 140°
Helix angle: 30°

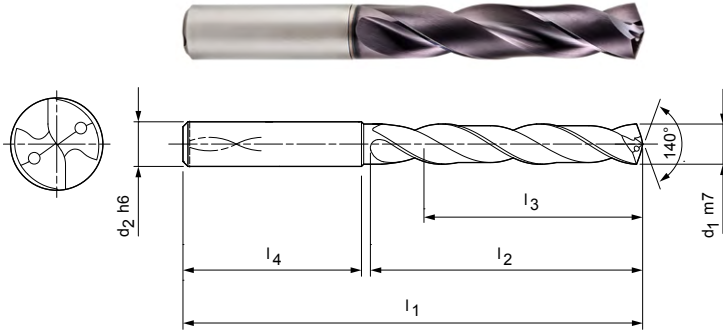

Stocked preferred series in shank form HA

Dimensions						Shank form HA	
d ₁ m7	d ₂ h6	l ₁	l ₂	l ₃	l ₄	Specification	Order no.
3,00	6	66	28	23	36	SCD361-0300-2-2-140HA05-HP132	30421524
3,10	6	66	28	23	36	SCD361-0310-2-2-140HA05-HP132	30421525
3,20	6	66	28	23	36	SCD361-0320-2-2-140HA05-HP132	30421526
3,30	6	66	28	23	36	SCD361-0330-2-2-140HA05-HP132	30421528
3,40	6	66	28	23	36	SCD361-0340-2-2-140HA05-HP132	30421529
3,50	6	66	28	23	36	SCD361-0350-2-2-140HA05-HP132	30421530
3,60	6	66	28	23	36	SCD361-0360-2-2-140HA05-HP132	30421531
3,70*	6	66	28	23	36	SCD361-0370-2-2-140HA05-HP132	30421532
3,80	6	74	36	29	36	SCD361-0380-2-2-140HA05-HP132	30421533
3,90	6	74	36	29	36	SCD361-0390-2-2-140HA05-HP132	30421534
4,00	6	74	36	29	36	SCD361-0400-2-2-140HA05-HP132	30421535
4,10	6	74	36	29	36	SCD361-0410-2-2-140HA05-HP132	30421536
4,20	6	74	36	29	36	SCD361-0420-2-2-140HA05-HP132	30421537
4,30	6	74	36	29	36	SCD361-0430-2-2-140HA05-HP132	30421539
4,40	6	74	36	29	36	SCD361-0440-2-2-140HA05-HP132	30421540
4,50	6	74	36	29	36	SCD361-0450-2-2-140HA05-HP132	30421541
4,60	6	74	36	29	36	SCD361-0460-2-2-140HA05-HP132	30421542
4,65*	6	74	36	29	36	SCD361-0465-2-2-140HA05-HP132	30421543
4,70	6	74	36	29	36	SCD361-0470-2-2-140HA05-HP132	30421544
4,80	6	82	44	35	36	SCD361-0480-2-2-140HA05-HP132	30421545
4,90	6	82	44	35	36	SCD361-0490-2-2-140HA05-HP132	30421546
5,00	6	82	44	35	36	SCD361-0500-2-2-140HA05-HP132	30421548
5,10	6	82	44	35	36	SCD361-0510-2-2-140HA05-HP132	30421550
5,20	6	82	44	35	36	SCD361-0520-2-2-140HA05-HP132	30421551
5,30	6	82	44	35	36	SCD361-0530-2-2-140HA05-HP132	30421552
5,40	6	82	44	35	36	SCD361-0540-2-2-140HA05-HP132	30421553
5,50	6	82	44	35	36	SCD361-0550-2-2-140HA05-HP132	30421554
5,55*	6	82	44	35	36	SCD361-0555-2-2-140HA05-HP132	30421555
5,60	6	82	44	35	36	SCD361-0560-2-2-140HA05-HP132	30421556
5,70	6	82	44	35	36	SCD361-0570-2-2-140HA05-HP132	30421557
5,80	6	82	44	35	36	SCD361-0580-2-2-140HA05-HP132	30421559
5,90	6	82	44	35	36	SCD361-0590-2-2-140HA05-HP132	30421560
6,00	6	82	44	35	36	SCD361-0600-2-2-140HA05-HP132	30421561
6,10	8	91	53	43	36	SCD361-0610-2-2-140HA05-HP132	30421562
6,20	8	91	53	43	36	SCD361-0620-2-2-140HA05-HP132	30421563

ECU-Drill-Steel | Solid carbide twist drill SCD361 (5xD), internal coolant supply

Dimensions						Shank form HA	
d ₁ m7	d ₂ h6	l ₁	l ₂	l ₃	l ₄	Specification	Order no.
6,30	8	91	53	43	36	SCD361-0630-2-2-140HA05-HP132	30421564
6,40	8	91	53	43	36	SCD361-0640-2-2-140HA05-HP132	30421565
6,50	8	91	53	43	36	SCD361-0650-2-2-140HA05-HP132	30421566
6,60	8	91	53	43	36	SCD361-0660-2-2-140HA05-HP132	30421567
6,70	8	91	53	43	36	SCD361-0670-2-2-140HA05-HP132	30421568
6,80	8	91	53	43	36	SCD361-0680-2-2-140HA05-HP132	30421569
6,90	8	91	53	43	36	SCD361-0690-2-2-140HA05-HP132	30421570
7,00	8	91	53	43	36	SCD361-0700-2-2-140HA05-HP132	30421571
7,10	8	91	53	43	36	SCD361-0710-2-2-140HA05-HP132	30421572
7,20	8	91	53	43	36	SCD361-0720-2-2-140HA05-HP132	30421573
7,30	8	91	53	43	36	SCD361-0730-2-2-140HA05-HP132	30421574
7,40	8	91	53	43	36	SCD361-0740-2-2-140HA05-HP132	30421575
7,45*	8	91	53	43	36	SCD361-0745-2-2-140HA05-HP132	30421576
7,50	8	91	53	43	36	SCD361-0750-2-2-140HA05-HP132	30421577
7,60	8	91	53	43	36	SCD361-0760-2-2-140HA05-HP132	30421579
7,70	8	91	53	43	36	SCD361-0770-2-2-140HA05-HP132	30421580
7,80	8	91	53	43	36	SCD361-0780-2-2-140HA05-HP132	30421581
7,90	8	91	53	43	36	SCD361-0790-2-2-140HA05-HP132	30421582
8,00	8	91	53	43	36	SCD361-0800-2-2-140HA05-HP132	30421583
8,10	10	103	61	49	40	SCD361-0810-2-2-140HA05-HP132	30421584
8,20	10	103	61	49	40	SCD361-0820-2-2-140HA05-HP132	30421585
8,30	10	103	61	49	40	SCD361-0830-2-2-140HA05-HP132	30421586
8,40	10	103	61	49	40	SCD361-0840-2-2-140HA05-HP132	30421587
8,50	10	103	61	49	40	SCD361-0850-2-2-140HA05-HP132	30421588
8,60	10	103	61	49	40	SCD361-0860-2-2-140HA05-HP132	30421589
8,70	10	103	61	49	40	SCD361-0870-2-2-140HA05-HP132	30421590
8,80	10	103	61	49	40	SCD361-0880-2-2-140HA05-HP132	30421591
8,90	10	103	61	49	40	SCD361-0890-2-2-140HA05-HP132	30421592
9,00	10	103	61	49	40	SCD361-0900-2-2-140HA05-HP132	30421593
9,10	10	103	61	49	40	SCD361-0910-2-2-140HA05-HP132	30421594
9,20	10	103	61	49	40	SCD361-0920-2-2-140HA05-HP132	30421595
9,30*	10	103	61	49	40	SCD361-0930-2-2-140HA05-HP132	30421597
9,35	10	103	61	49	40	SCD361-0935-2-2-140HA05-HP132	30421598
9,40	10	103	61	49	40	SCD361-0940-2-2-140HA05-HP132	30421599
9,50	10	103	61	49	40	SCD361-0950-2-2-140HA05-HP132	30421600
9,60	10	103	61	49	40	SCD361-0960-2-2-140HA05-HP132	30421601
9,70	10	103	61	49	40	SCD361-0970-2-2-140HA05-HP132	30421602
9,80	10	103	61	49	40	SCD361-0980-2-2-140HA05-HP132	30421603
9,90	10	103	61	49	40	SCD361-0990-2-2-140HA05-HP132	30421604
10,00	10	103	61	49	40	SCD361-1000-2-2-140HA05-HP132	30421605
10,10	12	118	71	56	45	SCD361-1010-2-2-140HA05-HP132	30421606
10,20	12	118	71	56	45	SCD361-1020-2-2-140HA05-HP132	30421607
10,30	12	118	71	56	45	SCD361-1030-2-2-140HA05-HP132	30421608
10,40	12	118	71	56	45	SCD361-1040-2-2-140HA05-HP132	30421609
10,50	12	118	71	56	45	SCD361-1050-2-2-140HA05-HP132	30421610
10,60	12	118	71	56	45	SCD361-1060-2-2-140HA05-HP132	30421612
10,70	12	118	71	56	45	SCD361-1070-2-2-140HA05-HP132	30421613
10,80	12	118	71	56	45	SCD361-1080-2-2-140HA05-HP132	30421615
10,90	12	118	71	56	45	SCD361-1090-2-2-140HA05-HP132	30421616
11,00	12	118	71	56	45	SCD361-1100-2-2-140HA05-HP132	30421617
11,10	12	118	71	56	45	SCD361-1110-2-2-140HA05-HP132	30421618
11,20*	12	118	71	56	45	SCD361-1120-2-2-140HA05-HP132	30421619
11,25	12	118	71	56	45	SCD361-1125-2-2-140HA05-HP132	30421620
11,30	12	118	71	56	45	SCD361-1130-2-2-140HA05-HP132	30421621
11,40	12	118	71	56	45	SCD361-1140-2-2-140HA05-HP132	30421622
11,50	12	118	71	56	45	SCD361-1150-2-2-140HA05-HP132	30421623
11,60	12	118	71	56	45	SCD361-1160-2-2-140HA05-HP132	30421624

Continued on next page.

ECU-Drill-Steel | Solid carbide twist drill SCD361 (5xD), internal coolant supply

Dimensions						Shank form HA	
d ₁ m7	d ₂ h6	l ₁	l ₂	l ₃	l ₄	Specification	Order no.
11,70	12	118	71	56	45	SCD361-1170-2-2-140HA05-HP132	30421625
11,80	12	118	71	56	45	SCD361-1180-2-2-140HA05-HP132	30421626
11,90	12	118	71	56	45	SCD361-1190-2-2-140HA05-HP132	30421628
12,00	12	118	71	56	45	SCD361-1200-2-2-140HA05-HP132	30421629
12,20	14	124	77	60	45	SCD361-1220-2-2-140HA05-HP132	30569175
12,25	14	124	77	60	45	SCD361-1225-2-2-140HA05-HP132	30421630
12,50	14	124	77	60	45	SCD361-1250-2-2-140HA05-HP132	30421632
12,70	14	124	77	60	45	SCD361-1270-2-2-140HA05-HP132	30421633
12,80	14	124	77	60	45	SCD361-1280-2-2-140HA05-HP132	30421634
12,90	14	124	77	60	45	SCD361-1290-2-2-140HA05-HP132	30421635
13,00	14	124	77	60	45	SCD361-1300-2-2-140HA05-HP132	30421636
13,10	14	124	77	60	45	SCD361-1310-2-2-140HA05-HP132	30421637
13,20	14	124	77	60	45	SCD361-1320-2-2-140HA05-HP132	30421638
13,50	14	124	77	60	45	SCD361-1350-2-2-140HA05-HP132	30421640
13,70	14	124	77	60	45	SCD361-1370-2-2-140HA05-HP132	30421641
13,80	14	124	77	60	45	SCD361-1380-2-2-140HA05-HP132	30421642
14,00	14	124	77	60	45	SCD361-1400-2-2-140HA05-HP132	30421643
14,20	16	133	83	63	48	SCD361-1420-2-2-140HA05-HP132	30421644
14,50	16	133	83	63	48	SCD361-1450-2-2-140HA05-HP132	30421645
14,70	16	133	83	63	48	SCD361-1470-2-2-140HA05-HP132	30421646
14,80	16	133	83	63	48	SCD361-1480-2-2-140HA05-HP132	30421647
15,00	16	133	83	63	48	SCD361-1500-2-2-140HA05-HP132	30421648
15,10	16	133	83	63	48	SCD361-1510-2-2-140HA05-HP132	30421649
15,25	16	133	83	63	48	SCD361-1525-2-2-140HA05-HP132	30421650
15,30	16	133	83	63	48	SCD361-1530-2-2-140HA05-HP132	30421651
15,50	16	133	83	63	48	SCD361-1550-2-2-140HA05-HP132	30421652
15,70	16	133	83	63	48	SCD361-1570-2-2-140HA05-HP132	30421654
15,80	16	133	83	63	48	SCD361-1580-2-2-140HA05-HP132	30421655
16,00	16	133	83	63	48	SCD361-1600-2-2-140HA05-HP132	30421656
16,50	18	143	93	71	48	SCD361-1650-2-2-140HA05-HP132	30421657
16,80	18	143	93	71	48	SCD361-1680-2-2-140HA05-HP132	30421658
17,00	18	143	93	71	48	SCD361-1700-2-2-140HA05-HP132	30421660
17,50	18	143	93	71	48	SCD361-1750-2-2-140HA05-HP132	30421661
17,80	18	143	93	71	48	SCD361-1780-2-2-140HA05-HP132	30421663
18,00	18	143	93	71	48	SCD361-1800-2-2-140HA05-HP132	30421664
18,50	20	153	101	77	50	SCD361-1850-2-2-140HA05-HP132	30421665
18,80	20	153	101	77	50	SCD361-1880-2-2-140HA05-HP132	30421666
19,00	20	153	101	77	50	SCD361-1900-2-2-140HA05-HP132	30421668
19,50	20	153	101	77	50	SCD361-1950-2-2-140HA05-HP132	30421669
19,80	20	153	101	77	50	SCD361-1980-2-2-140HA05-HP132	30421671
20,00	20	153	101	77	50	SCD361-2000-2-2-140HA05-HP132	30421672

Configurable features



Shank form:
Shank form: HB | HE



Specification:
SCD361-0430-2-2-140[shank form]05-HP132

Example:

SCD361-0430-2-2-140HE05-HP132

Shank form HE

Dimensions in mm.

* Particularly suitable for the premanufacturing of core holes for thread formers.

For cutting data recommendations, see end of chapter.

Special designs and other coatings available upon request.

ECU-Drill-Steel

Solid carbide twist drill
SCD361 (8xD), internal coolant supply

Design:
 Drill diameter: 3.00 - 20.00 mm
 Bore tolerance: \geq IT 9
 Cutting material: HP132
 Number of cutting edges: 2
 Tip angle: 135°
 Helix angle: 30°

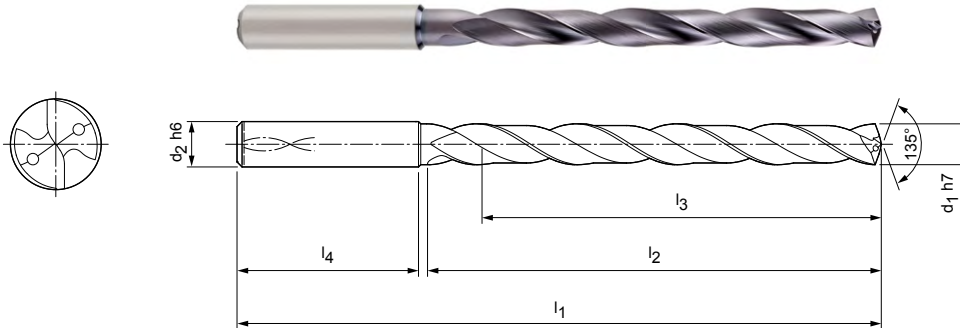

Stocked preferred series in shank form HA

Dimensions						Shank form HA	
d ₁ h7	d ₂ h6	l ₁	l ₂	l ₃	l ₄	Specification	Order no.
3,00	6	72	34	29	36	SCD361-0300-2-2-135HA08-HP132	30677713
3,10	6	72	34	29	36	SCD361-0310-2-2-135HA08-HP132	30677714
3,20	6	72	34	29	36	SCD361-0320-2-2-135HA08-HP132	30677715
3,30	6	72	34	29	36	SCD361-0330-2-2-135HA08-HP132	30677716
3,40	6	72	34	29	36	SCD361-0340-2-2-135HA08-HP132	30677717
3,50	6	72	34	29	36	SCD361-0350-2-2-135HA08-HP132	30677718
3,60	6	72	34	29	36	SCD361-0360-2-2-135HA08-HP132	30677719
3,70	6	72	34	29	36	SCD361-0370-2-2-135HA08-HP132	30677720
3,80	6	81	43	36	36	SCD361-0380-2-2-135HA08-HP132	30677721
3,90	6	81	43	36	36	SCD361-0390-2-2-135HA08-HP132	30677722
4,00	6	81	43	36	36	SCD361-0400-2-2-135HA08-HP132	30677723
4,10	6	81	43	36	36	SCD361-0410-2-2-135HA08-HP132	30677724
4,20	6	81	43	36	36	SCD361-0420-2-2-135HA08-HP132	30677725
4,30	6	81	43	36	36	SCD361-0430-2-2-135HA08-HP132	30677726
4,40	6	81	43	36	36	SCD361-0440-2-2-135HA08-HP132	30677727
4,50	6	81	43	36	36	SCD361-0450-2-2-135HA08-HP132	30677728
4,60	6	81	43	36	36	SCD361-0460-2-2-135HA08-HP132	30677729
4,70	6	81	43	36	36	SCD361-0470-2-2-135HA08-HP132	30677730
4,80	6	95	57	48	36	SCD361-0480-2-2-135HA08-HP132	30677731
4,90	6	95	57	48	36	SCD361-0490-2-2-135HA08-HP132	30677732
5,00	6	95	57	48	36	SCD361-0500-2-2-135HA08-HP132	30677733
5,10	6	95	57	48	36	SCD361-0510-2-2-135HA08-HP132	30677734
5,20	6	95	57	48	36	SCD361-0520-2-2-135HA08-HP132	30677735
5,30	6	95	57	48	36	SCD361-0530-2-2-135HA08-HP132	30677736
5,50	6	95	57	48	36	SCD361-0550-2-2-135HA08-HP132	30677738
5,70	6	95	57	48	36	SCD361-0570-2-2-135HA08-HP132	30677740
5,80	6	95	57	48	36	SCD361-0580-2-2-135HA08-HP132	30677741
5,90	6	95	57	48	36	SCD361-0590-2-2-135HA08-HP132	30677742
6,00	6	95	57	48	36	SCD361-0600-2-2-135HA08-HP132	30677743
6,10	8	114	76	64	36	SCD361-0610-2-2-135HA08-HP132	30677744
6,20	8	114	76	64	36	SCD361-0620-2-2-135HA08-HP132	30677745
6,30	8	114	76	64	36	SCD361-0630-2-2-135HA08-HP132	30677746
6,50	8	114	76	64	36	SCD361-0650-2-2-135HA08-HP132	30677748
6,60	8	114	76	64	36	SCD361-0660-2-2-135HA08-HP132	30677749
6,70	8	114	76	64	36	SCD361-0670-2-2-135HA08-HP132	30677751

ECU-Drill-Steel | Solid carbide twist drill SCD361 (8xD), internal coolant supply

Dimensions						Shank form HA	
d ₁ h7	d ₂ h6	l ₁	l ₂	l ₃	l ₄	Specification	Order no.
6,80	8	114	76	64	36	SCD361-0680-2-2-135HA08-HP132	30677752
6,90	8	114	76	64	36	SCD361-0690-2-2-135HA08-HP132	30677753
7,00	8	114	76	64	36	SCD361-0700-2-2-135HA08-HP132	30677754
7,10	8	114	76	64	36	SCD361-0710-2-2-135HA08-HP132	30677755
7,40	8	114	76	64	36	SCD361-0740-2-2-135HA08-HP132	30677758
7,50	8	114	76	64	36	SCD361-0750-2-2-135HA08-HP132	30677759
7,70	8	114	76	64	36	SCD361-0770-2-2-135HA08-HP132	30677761
7,80	8	114	76	64	36	SCD361-0780-2-2-135HA08-HP132	30677762
7,90	8	114	76	64	36	SCD361-0790-2-2-135HA08-HP132	30677763
8,00	8	114	76	64	36	SCD361-0800-2-2-135HA08-HP132	30677764
8,10	10	142	95	80	40	SCD361-0810-2-2-135HA08-HP132	30677765
8,20	10	142	95	80	40	SCD361-0820-2-2-135HA08-HP132	30677766
8,30	10	142	95	80	40	SCD361-0830-2-2-135HA08-HP132	30677767
8,50	10	142	95	80	40	SCD361-0850-2-2-135HA08-HP132	30677769
8,60	10	142	95	80	40	SCD361-0860-2-2-135HA08-HP132	30677770
8,70	10	142	95	80	40	SCD361-0870-2-2-135HA08-HP132	30677750
8,80	10	142	95	80	40	SCD361-0880-2-2-135HA08-HP132	30677773
9,00	10	142	95	80	40	SCD361-0900-2-2-135HA08-HP132	30677775
9,10	10	142	95	80	40	SCD361-0910-2-2-135HA08-HP132	30677776
9,20	10	142	95	80	40	SCD361-0920-2-2-135HA08-HP132	30677777
9,30	10	142	95	80	40	SCD361-0930-2-2-135HA08-HP132	30677778
9,40	10	142	95	80	40	SCD431-0940-2-2-135HA08-HP765	30550363
9,50	10	142	95	80	40	SCD361-0950-2-2-135HA08-HP132	30677780
9,70	10	142	95	80	40	SCD361-0970-2-2-135HA08-HP132	30677782
9,80	10	142	95	80	40	SCD361-0980-2-2-135HA08-HP132	30677783
9,90	10	142	95	80	40	SCD361-0990-2-2-135HA08-HP132	30677784
10,00	10	142	95	80	40	SCD361-1000-2-2-135HA08-HP132	30677785
10,20	12	162	114	96	45	SCD361-1020-2-2-135HA08-HP132	30677787
10,30	12	162	114	96	45	SCD361-1030-2-2-135HA08-HP132	30677788
10,50	12	162	114	96	45	SCD361-1050-2-2-135HA08-HP132	30677790
10,80	12	162	114	96	45	SCD361-1080-2-2-135HA08-HP132	30677793
11,00	12	162	114	96	45	SCD361-1100-2-2-135HA08-HP132	30677795
11,20	12	162	114	96	45	SCD361-1120-2-2-135HA08-HP132	30677797
11,50	12	162	114	96	45	SCD361-1150-2-2-135HA08-HP132	30677800
11,70	12	162	114	96	45	SCD361-1170-2-2-135HA08-HP132	30677802
11,80	12	162	114	96	45	SCD361-1180-2-2-135HA08-HP132	30677803
12,00	12	162	114	96	45	SCD361-1200-2-2-135HA08-HP132	30677805
12,20	14	178	133	112	45	SCD361-1220-2-2-135HA08-HP132	30677806
12,50	14	178	133	112	45	SCD361-1250-2-2-135HA08-HP132	30677807
12,80	14	178	133	112	45	SCD361-1280-2-2-135HA08-HP132	30677808
13,00	14	178	133	112	45	SCD361-1300-2-2-135HA08-HP132	30677809
13,50	14	178	133	112	45	SCD361-1350-2-2-135HA08-HP132	30677811
13,80	14	178	133	112	45	SCD361-1380-2-2-135HA08-HP132	30677812
14,00	14	178	133	112	45	SCD361-1400-2-2-135HA08-HP132	30677813
14,50	16	203	152	128	48	SCD361-1450-2-2-135HA08-HP132	30677815
15,00	16	203	152	128	48	SCD361-1500-2-2-135HA08-HP132	30677817
15,50	16	203	152	128	48	SCD361-1550-2-2-135HA08-HP132	30677818
15,80	16	203	152	128	48	SCD361-1580-2-2-135HA08-HP132	30677819
16,00	16	203	152	128	48	SCD361-1600-2-2-135HA08-HP132	30677820
16,50	18	222	171	144	48	SCD361-1650-2-2-135HA08-HP132	30677821
17,00	18	222	171	144	48	SCD361-1700-2-2-135HA08-HP132	30677822
17,50	18	222	171	144	48	SCD361-1750-2-2-135HA08-HP132	30677823
18,00	18	222	171	144	48	SCD361-1800-2-2-135HA08-HP132	30677824
18,50	20	243	190	160	50	SCD361-1850-2-2-135HA08-HP132	30677825
19,00	20	243	190	160	50	SCD361-1900-2-2-135HA08-HP132	30677826
20,00	20	243	190	160	50	SCD361-2000-2-2-135HA08-HP132	30677828

ECU-Drill-Steel | Solid carbide twist drill SCD361 (8xD), internal coolant supply

Configurable features



Shank form:
Shank form: HB | HE



Specification:
SCD361-0430-2-2-140[shank form]08-HP132

Example:

SCD361-0430-2-2-140HE08-HP132

Shank form HE

ECU-Drill-Steel

Solid carbide twist drill
SCD361 (12xD), internal coolant supply

Design:

Drill diameter: 3.00 - 18.00 mm
Bore tolerance: \geq IT 9
Cutting material: HP132
Number of cutting edges: 2
Tip angle: 135°
Helix angle: 30°

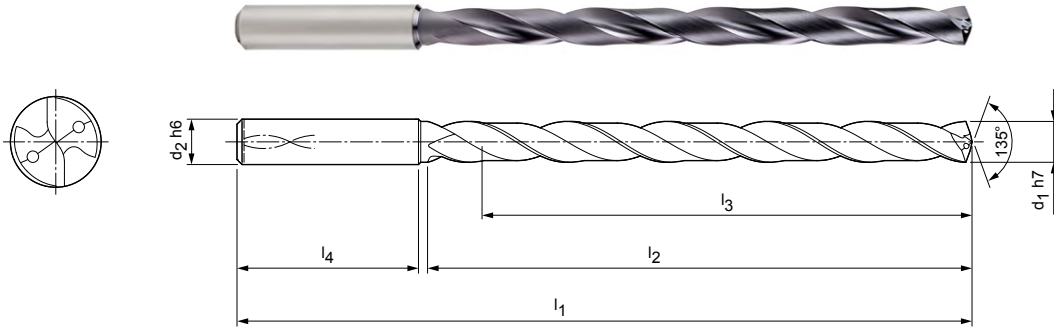

Stocked preferred series in shank form HA

Dimensions						Shank form HA	
d ₁ h7	d ₂ h6	l ₁	l ₂	l ₃	l ₄	Specification	Order no.
3,00	6	92	54	48	36	SCD361-0300-2-2-135HA12-HP132	30677829
3,10	6	92	54	48	36	SCD361-0310-2-2-135HA12-HP132	30677830
3,20	6	92	54	48	36	SCD361-0320-2-2-135HA12-HP132	30677831
3,30	6	92	54	48	36	SCD361-0330-2-2-135HA12-HP132	30677832
3,40	6	92	54	48	36	SCD361-0340-2-2-135HA12-HP132	30677833
3,50	6	92	54	48	36	SCD361-0350-2-2-135HA12-HP132	30677834
3,60	6	92	54	48	36	SCD361-0360-2-2-135HA12-HP132	30677835
3,70	6	92	54	48	36	SCD361-0370-2-2-135HA12-HP132	30677836
3,80	6	102	64	58	36	SCD361-0380-2-2-135HA12-HP132	30677837
3,90	6	102	64	58	36	SCD361-0390-2-2-135HA12-HP132	30677838
4,00	6	102	64	58	36	SCD361-0400-2-2-135HA12-HP132	30677839
4,10	6	102	64	58	36	SCD361-0410-2-2-135HA12-HP132	30677840
4,20	6	102	64	58	36	SCD361-0420-2-2-135HA12-HP132	30677841
4,30	6	102	64	58	36	SCD361-0430-2-2-135HA12-HP132	30677842
4,40	6	102	64	58	36	SCD361-0440-2-2-135HA12-HP132	30677843
4,50	6	102	64	58	36	SCD361-0450-2-2-135HA12-HP132	30677844
4,60	6	102	64	58	36	SCD361-0460-2-2-135HA12-HP132	30677845
4,70	6	102	64	58	36	SCD361-0470-2-2-135HA12-HP132	30677846
4,80	6	116	78	70	36	SCD361-0480-2-2-135HA12-HP132	30677847
4,90	6	116	78	70	36	SCD361-0490-2-2-135HA12-HP132	30677848
5,00	6	116	78	70	36	SCD361-0500-2-2-135HA12-HP132	30677849
5,10	6	116	78	70	36	SCD361-0510-2-2-135HA12-HP132	30677850
5,20	6	116	78	70	36	SCD361-0520-2-2-135HA12-HP132	30677851
5,50	6	116	78	70	36	SCD361-0550-2-2-135HA12-HP132	30677853
5,80	6	116	78	70	36	SCD361-0580-2-2-135HA12-HP132	30677854
6,00	6	116	78	70	36	SCD361-0600-2-2-135HA12-HP132	30677856
6,30	8	146	108	94	36	SCD361-0630-2-2-135HA12-HP132	30677859
6,50	8	146	108	94	36	SCD361-0650-2-2-135HA12-HP132	30677860
6,60	8	146	108	94	36	SCD361-0660-2-2-135HA12-HP132	30677861
6,80	8	146	108	94	36	SCD361-0680-2-2-135HA12-HP132	30677862
7,00	8	146	108	94	36	SCD361-0700-2-2-135HA12-HP132	30677863
7,40	8	146	108	94	36	SCD361-0740-2-2-135HA12-HP132	30677864
7,50	8	146	108	94	36	SCD361-0750-2-2-135HA12-HP132	30677865
7,80	8	146	108	94	36	SCD361-0780-2-2-135HA12-HP132	30677867
8,00	8	146	108	94	36	SCD361-0800-2-2-135HA12-HP132	30677869

ECU-Drill-Steel | Solid carbide twist drill SCD361 (12xD), internal coolant supply

Dimensions						Shank form HA	
d ₁ h7	d ₂ h6	l ₁	l ₂	l ₃	l ₄	Specification	Order no.
8,10	10	162	120	110	40	SCD361-0810-2-2-135HA12-HP132	30677870
8,20	10	162	120	110	40	SCD361-0820-2-2-135HA12-HP132	30677871
8,50	10	162	120	110	40	SCD361-0850-2-2-135HA12-HP132	30677874
9,00	10	162	120	110	40	SCD361-0900-2-2-135HA12-HP132	30677878
9,30	10	162	120	110	40	SCD361-0930-2-2-135HA12-HP132	30677881
9,50	10	162	120	110	40	SCD361-0950-2-2-135HA12-HP132	30677883
9,80	10	162	120	110	40	SCD361-0980-2-2-135HA12-HP132	30677885
10,00	10	162	120	110	40	SCD361-1000-2-2-135HA12-HP132	30677887
10,20	12	204	156	142	45	SCD361-1020-2-2-135HA12-HP132	30677888
10,50	12	204	156	142	45	SCD361-1050-2-2-135HA12-HP132	30677889
11,00	12	204	156	142	45	SCD361-1100-2-2-135HA12-HP132	30677891
11,50	12	204	156	142	45	SCD361-1150-2-2-135HA12-HP132	30677893
11,80	12	204	156	142	45	SCD361-1180-2-2-135HA12-HP132	30677894
12,00	12	204	156	142	45	SCD361-1200-2-2-135HA12-HP132	30677895
12,50	14	230	182	166	45	SCD361-1250-2-2-135HA12-HP132	30677896
13,00	14	230	182	166	45	SCD361-1300-2-2-135HA12-HP132	30677897
13,50	14	230	182	166	45	SCD361-1350-2-2-135HA12-HP132	30677899
14,00	14	230	182	166	45	SCD361-1400-2-2-135HA12-HP132	30677900
15,00	16	260	208	192	48	SCD361-1500-2-2-135HA12-HP132	30677903
16,00	16	260	208	192	48	SCD361-1600-2-2-135HA12-HP132	30677906
17,00	18	285	234	216	48	SCD361-1700-2-2-135HA12-HP132	30677908
17,50	18	285	234	216	48	SCD361-1750-2-2-135HA12-HP132	30677909
18,00	18	285	234	216	48	SCD361-1800-2-2-135HA12-HP132	30677910

Configurable features



Shank form:
Shank form: HB | HE



Specification:
SCD361-0430-2-2-140[shank form]12-HP132

Example:
SCD361-0430-2-2-140HE12-HP132

Shank form HE

Dimensions in mm.

For cutting data recommendations, see end of chapter.

Special designs and other coatings available upon request.

MICRO-Drill-Steel

Solid carbide twist drill
SCD371 (5xD), internal coolant supply

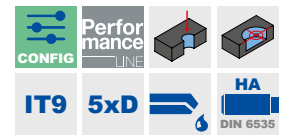
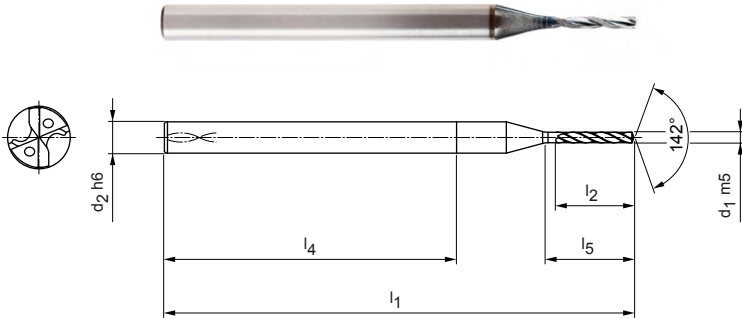

Design:
 Drill diameter: 0.80 – 2.99 mm
 Bore tolerance: IT9 (available)
 Cutting material: HP246
 Number of cutting edges: 2
 Number of guiding chamfers: 4
 Tip angle: 142°
 Helix angle: 30°

Application:
 Pilot drill specifically designed for the MEGA-Deep-Drill.
 Maximum use up to < diameter 3.00 mm.

Stocked preferred series in shank form HA

Dimensions						Shank form HA	
d ₁ m5	d ₂ h6	l ₁	l ₂	l ₃	l ₄	Specification	Order no.
0,80	3	45	6	4	28	SCD371-0080-2-4-142HA05-HP246	31238823
1,00	3	45	7,5	5	28	SCD371-0100-2-4-142HA05-HP246	31238825
1,20	3	45	9	6	28	SCD371-0120-2-4-142HA05-HP246	31238827
1,50	3	45	11,3	7,5	28	SCD371-0150-2-4-142HA05-HP246	31238890
1,60	3	50	12	8	28	SCD371-0160-2-4-142HA05-HP246	31238891
2,00	3	50	15	10	28	SCD371-0200-2-4-142HA05-HP246	31238895
2,40	3	52	18	12	28	SCD371-0240-2-4-142HA05-HP246	31238899
2,50	3	52	18,8	12,5	28	SCD371-0250-2-4-142HA05-HP246	31238900
2,60	3	55	19,5	13	28	SCD371-0260-2-4-142HA05-HP246	31238901
2,80	3	55	21	14	28	SCD371-0280-2-4-142HA05-HP246	31238903

Configurable features



Diameter:
Diameter in increments of 0.01 mm freely selectable



Specification:
SCD371-[Diameter]-2-4-142HA05-HP246

Dimensions of configurable series

d ₁ min.	d ₁ max.	d ₂ h6	l ₁	l ₂	l ₃	l ₄
0,80	0,99	3	45	6,0	4,0	28
1,00	1,29	3	45	7,5	5,0	28
1,30	1,59	3	45	9,8	6,5	28
1,60	1,89	3	50	12,0	8,0	28
1,90	2,19	3	50	14,3	9,5	28
2,20	2,59	3	52	16,5	11,0	28
2,60	2,99	3	55	19,5	13,0	28

Example:

SCD371-0221-2-4-142HA05-HP246

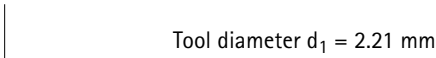

Dimensions in mm.
 For cutting data recommendations, see end of chapter.
 Special designs and other coatings available upon request.

MICRO-Drill-Steel

Solid carbide twist drill
SCD371 (8xD), internal coolant supply

Design:
 Drill diameter: 1.00 – 2.99 mm
 Bore tolerance: IT9 (available)
 Cutting material: HP246
 Number of cutting edges: 2
 Number of guiding chamfers: 4
 Tip angle: 142°
 Helix angle: 30°

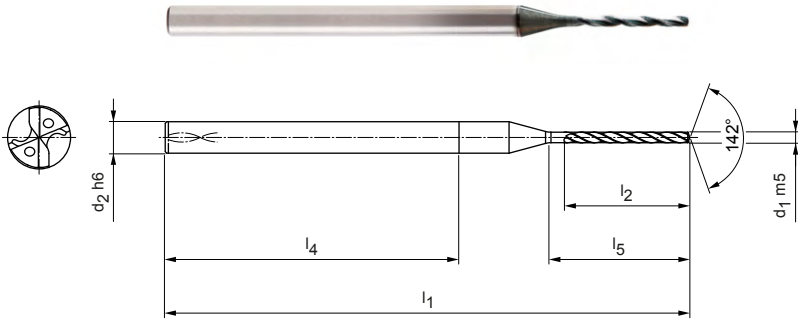

Stocked preferred series in shank form HA

Dimensions						Shank form HA	
d ₁ m5	d ₂ h6	l ₁	l ₂	l ₃	l ₄	Specification	Order no.
1,00	3	50	12	8	28	SCD371-0100-2-4-142HA08-HP246	31238905
1,20	3	50	14,4	9,6	28	SCD371-0120-2-4-142HA08-HP246	31238907
1,50	3	52	18	12	28	SCD371-0150-2-4-142HA08-HP246	31238910
1,60	3	55	19,2	12,8	28	SCD371-0160-2-4-142HA08-HP246	31238911
2,00	3	60	24	16	28	SCD371-0200-2-4-142HA08-HP246	31238915
2,50	3	62	30	20	28	SCD371-0250-2-4-142HA08-HP246	31238920

Configurable features



Diameter:
Diameter in increments of 0.01 mm freely selectable

Specification:
SCD371-[Diameter]-2-4-142HA08-HP246

Dimensions of configurable series

d ₁ min.	d ₁ max.	d ₂ h6	l ₁	l ₂	l ₃	l ₄
1,00	1,29	3	50	12,0	8,0	28
1,30	1,59	3	52	15,6	10,4	28
1,60	1,89	3	55	19,2	12,8	28
1,90	2,19	3	60	22,8	15,2	28
2,20	2,59	3	62	26,4	17,6	28
2,60	2,99	3	66	31,2	20,8	28

Example:

SCD371-0221-2-4-142HA08-HP246

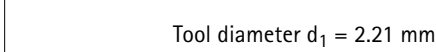

Dimensions in mm.
 For cutting data recommendations, see end of chapter.
 Special designs and other coatings available upon request.

MICRO-Drill-Steel

Solid carbide twist drill
SCD371 (12xD), internal coolant supply

Design:
 Drill diameter: 1.00 – 2.99 mm
 Bore tolerance: IT9 (available)
 Cutting material: HP246
 Number of cutting edges: 2
 Number of guiding chamfers: 4
 Tip angle: 142°
 Helix angle: 30°

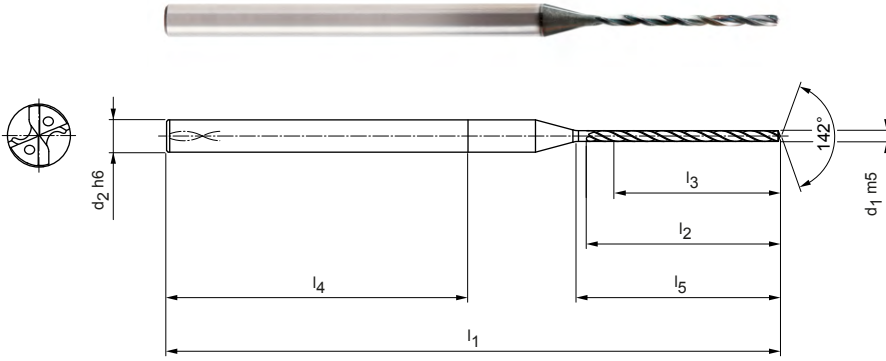

Stocked preferred series in shank form HA

Dimensions						Shank form HA	
d ₁ m5	d ₂ h6	l ₁	l ₂	l ₃	l ₄	Specification	Order no.
1,00	3	57	18	12	28	SCD371-0100-2-4-142HA12-HP246	31238925
1,20	3	57	21,6	14,4	28	SCD371-0120-2-4-142HA12-HP246	31238927
1,30	3	62	23,4	15,6	28	SCD371-0130-2-4-142HA12-HP246	31238928
1,50	3	62	27	18	28	SCD371-0150-2-4-142HA12-HP246	31238930
2,00	3	72	36	24	28	SCD371-0200-2-4-142HA12-HP246	31238935
2,50	3	79	45	30	28	SCD371-0250-2-4-142HA12-HP246	31238940

Configurable features



Diameter:
Diameter in increments of 0.01 mm freely selectable



Specification:
SCD371-[Diameter]-2-4-142HA12-HP246

Dimensions of configurable series

d ₁ min.	d ₁ max.	d ₂ h6	l ₁	l ₂	l ₃	l ₄
1,00	1,29	3	57	18,0	12,0	28
1,30	1,59	3	62	23,4	15,6	28
1,60	1,89	3	66	28,8	19,2	28
1,90	2,19	3	72	34,2	22,8	28
2,20	2,59	3	79	39,6	26,4	28
2,60	2,99	3	85	46,8	31,2	28

Example:

SCD371-0221-2-4-142HA12-HP246

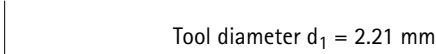

Dimensions in mm.
 For cutting data recommendations, see end of chapter.
 Special designs and other coatings available upon request.

MEGA-Drill-Steel-Plus

Solid carbide twist drill

SCD600 (3xD), external coolant supply, follow-up product to the MEGA-Drill-Steel (SCD10)

Design:

- Drill diameter: 3.00 - 25.00 mm
- Bore tolerance: \geq IT 9
- Cutting material: HP358
- Number of cutting edges: 2
- Number of guiding chamfers: 2
- Tip angle: 140°
- Helix angle: 30°

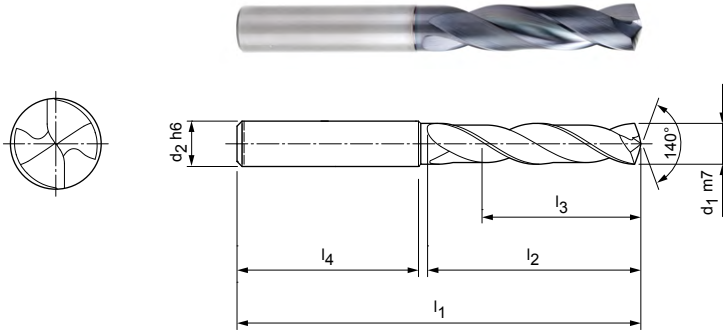

Stocked preferred series in shank form HA

Dimensions						Shank form HA	
d ₁ m7	d ₂ h6	l ₁	l ₂	l ₃	l ₄	Specification	Order no.
3,00	6	62	20	14	36	SCD600-0300-2-2-140HA03-HP358	30801131
3,10	6	62	20	14	36	SCD600-0310-2-2-140HA03-HP358	30801132
3,15	6	62	20	14	36	SCD600-0315-2-2-140HA03-HP358	30801133
3,20	6	62	20	14	36	SCD600-0320-2-2-140HA03-HP358	30801134
3,25	6	62	20	14	36	SCD600-0325-2-2-140HA03-HP358	30801136
3,30	6	62	20	14	36	SCD600-0330-2-2-140HA03-HP358	30801137
3,40	6	62	20	14	36	SCD600-0340-2-2-140HA03-HP358	30801138
3,50	6	62	20	14	36	SCD600-0350-2-2-140HA03-HP358	30801139
3,60	6	62	20	14	36	SCD600-0360-2-2-140HA03-HP358	30801140
3,70*	6	62	20	14	36	SCD600-0370-2-2-140HA03-HP358	30801141
3,80	6	66	24	17	36	SCD600-0380-2-2-140HA03-HP358	30801142
3,85	6	66	24	17	36	SCD600-0385-2-2-140HA03-HP358	30801143
3,90	6	66	24	17	36	SCD600-0390-2-2-140HA03-HP358	30801144
4,00	6	66	24	17	36	SCD600-0400-2-2-140HA03-HP358	30801145
4,10	6	66	24	17	36	SCD600-0410-2-2-140HA03-HP358	30801146
4,20	6	66	24	17	36	SCD600-0420-2-2-140HA03-HP358	30801147
4,25	6	66	24	17	36	SCD600-0425-2-2-140HA03-HP358	30801148
4,30	6	66	24	17	36	SCD600-0430-2-2-140HA03-HP358	30801149
4,35	6	66	24	17	36	SCD600-0435-2-2-140HA03-HP358	30801150
4,40	6	66	24	17	36	SCD600-0440-2-2-140HA03-HP358	30801151
4,45	6	66	24	17	36	SCD600-0445-2-2-140HA03-HP358	30801152
4,50	6	66	24	17	36	SCD600-0450-2-2-140HA03-HP358	30801153
4,60	6	66	24	17	36	SCD600-0460-2-2-140HA03-HP358	30801154
4,65*	6	66	24	17	36	SCD600-0465-2-2-140HA03-HP358	30801155
4,70	6	66	24	17	36	SCD600-0470-2-2-140HA03-HP358	30801156
4,80	6	66	28	20	36	SCD600-0480-2-2-140HA03-HP358	30801157
4,90	6	66	28	20	36	SCD600-0490-2-2-140HA03-HP358	30801158
4,95	6	66	28	20	36	SCD600-0495-2-2-140HA03-HP358	30801159
5,00	6	66	28	20	36	SCD600-0500-2-2-140HA03-HP358	30801160
5,05	6	66	28	20	36	SCD600-0505-2-2-140HA03-HP358	30801161
5,10	6	66	28	20	36	SCD600-0510-2-2-140HA03-HP358	30801162
5,20	6	66	28	20	36	SCD600-0520-2-2-140HA03-HP358	30801163
5,30	6	66	28	20	36	SCD600-0530-2-2-140HA03-HP358	30801164
5,40	6	66	28	20	36	SCD600-0540-2-2-140HA03-HP358	30801165
5,50	6	66	28	20	36	SCD600-0550-2-2-140HA03-HP358	30801166

MEGA-Drill-Steel-Plus | Solid carbide twist drill SCD600 (3xD), external coolant supply

Dimensions						Shank form HA	
d ₁ m7	d ₂ h6	l ₁	l ₂	l ₃	l ₄	Specification	Order no.
5,55*	6	66	28	20	36	SCD600-0555-2-2-140HA03-HP358	30801167
5,60	6	66	28	20	36	SCD600-0560-2-2-140HA03-HP358	30801168
5,70	6	66	28	20	36	SCD600-0570-2-2-140HA03-HP358	30801169
5,75	6	66	28	20	36	SCD600-0575-2-2-140HA03-HP358	30801170
5,80	6	66	28	20	36	SCD600-0580-2-2-140HA03-HP358	30801171
5,90	6	66	28	20	36	SCD600-0590-2-2-140HA03-HP358	30801172
5,95	6	66	28	20	36	SCD600-0595-2-2-140HA03-HP358	30801173
6,00	6	66	28	20	36	SCD600-0600-2-2-140HA03-HP358	30801174
6,10	8	79	34	24	36	SCD600-0610-2-2-140HA03-HP358	30801175
6,20	8	79	34	24	36	SCD600-0620-2-2-140HA03-HP358	30801176
6,30	8	79	34	24	36	SCD600-0630-2-2-140HA03-HP358	30801177
6,40	8	79	34	24	36	SCD600-0640-2-2-140HA03-HP358	30801178
6,50	8	79	34	24	36	SCD600-0650-2-2-140HA03-HP358	30801179
6,60	8	79	34	24	36	SCD600-0660-2-2-140HA03-HP358	30801180
6,70	8	79	34	24	36	SCD600-0670-2-2-140HA03-HP358	30801181
6,80	8	79	34	24	36	SCD600-0680-2-2-140HA03-HP358	30801182
6,90	8	79	34	24	36	SCD600-0690-2-2-140HA03-HP358	30801183
7,00	8	79	34	24	36	SCD600-0700-2-2-140HA03-HP358	30801184
7,10	8	79	41	29	36	SCD600-0710-2-2-140HA03-HP358	30801185
7,20	8	79	41	29	36	SCD600-0720-2-2-140HA03-HP358	30801186
7,30	8	79	41	29	36	SCD600-0730-2-2-140HA03-HP358	30801187
7,40	8	79	41	29	36	SCD600-0740-2-2-140HA03-HP358	30801188
7,45*	8	79	41	29	36	SCD600-0745-2-2-140HA03-HP358	30801189
7,50	8	79	41	29	36	SCD600-0750-2-2-140HA03-HP358	30801190
7,60	8	79	41	29	36	SCD600-0760-2-2-140HA03-HP358	30801191
7,70	8	79	41	29	36	SCD600-0770-2-2-140HA03-HP358	30801192
7,80	8	79	41	29	36	SCD600-0780-2-2-140HA03-HP358	30801193
7,90	8	79	41	29	36	SCD600-0790-2-2-140HA03-HP358	30801194
8,00	8	79	41	29	36	SCD600-0800-2-2-140HA03-HP358	30801195
8,10	10	89	47	35	40	SCD600-0810-2-2-140HA03-HP358	30801196
8,20	10	89	47	35	40	SCD600-0820-2-2-140HA03-HP358	30801197
8,30	10	89	47	35	40	SCD600-0830-2-2-140HA03-HP358	30801198
8,40	10	89	47	35	40	SCD600-0840-2-2-140HA03-HP358	30801199
8,50	10	89	47	35	40	SCD600-0850-2-2-140HA03-HP358	30801200
8,60	10	89	47	35	40	SCD600-0860-2-2-140HA03-HP358	30801201
8,70	10	89	47	35	40	SCD600-0870-2-2-140HA03-HP358	30801202
8,80	10	89	47	35	40	SCD600-0880-2-2-140HA03-HP358	30801203
8,90	10	89	47	35	40	SCD600-0890-2-2-140HA03-HP358	30801204
9,00	10	89	47	35	40	SCD600-0900-2-2-140HA03-HP358	30801205
9,10	10	89	47	35	40	SCD600-0910-2-2-140HA03-HP358	30801206
9,20	10	89	47	35	40	SCD600-0920-2-2-140HA03-HP358	30801207
9,30*	10	89	47	35	40	SCD600-0930-2-2-140HA03-HP358	30801208
9,35	10	89	47	35	40	SCD600-0935-2-2-140HA03-HP358	30801209
9,50	10	89	47	35	40	SCD600-0950-2-2-140HA03-HP358	30801212
9,60	10	89	47	35	40	SCD600-0960-2-2-140HA03-HP358	30801213
9,70	10	89	47	35	40	SCD600-0970-2-2-140HA03-HP358	30801214
9,80	10	89	47	35	40	SCD600-0980-2-2-140HA03-HP358	30801215
9,90	10	89	47	35	40	SCD600-0990-2-2-140HA03-HP358	30801216
10,00	10	89	47	35	40	SCD600-1000-2-2-140HA03-HP358	30801217
10,10	12	102	55	40	45	SCD600-1010-2-2-140HA03-HP358	30801218
10,20	12	102	55	40	45	SCD600-1020-2-2-140HA03-HP358	30801219
10,30	12	102	55	40	45	SCD600-1030-2-2-140HA03-HP358	30801220
10,40	12	102	55	40	45	SCD600-1040-2-2-140HA03-HP358	30801221
10,50	12	102	55	40	45	SCD600-1050-2-2-140HA03-HP358	30801222
10,55	12	102	55	40	45	SCD600-1055-2-2-140HA03-HP358	30801223
10,60	12	102	55	40	45	SCD600-1060-2-2-140HA03-HP358	30801224
10,70	12	102	55	40	45	SCD600-1070-2-2-140HA03-HP358	30801225

MEGA-Drill-Steel-Plus | Solid carbide twist drill SCD600 (3xD), external coolant supply

Dimensions						Shank form HA	
d ₁ m7	d ₂ h6	l ₁	l ₂	l ₃	l ₄	Specification	Order no.
10,80	12	102	55	40	45	SCD600-1080-2-2-140HA03-HP358	30801227
10,90	12	102	55	40	45	SCD600-1090-2-2-140HA03-HP358	30801228
11,00	12	102	55	40	45	SCD600-1100-2-2-140HA03-HP358	30801229
11,10	12	102	55	40	45	SCD600-1110-2-2-140HA03-HP358	30801230
11,20*	12	102	55	40	45	SCD600-1120-2-2-140HA03-HP358	30801231
11,25	12	102	55	40	45	SCD600-1125-2-2-140HA03-HP358	30801232
11,30	12	102	55	40	45	SCD600-1130-2-2-140HA03-HP358	30801233
11,35	12	102	55	40	45	SCD600-1135-2-2-140HA03-HP358	30801234
11,40	12	102	55	40	45	SCD600-1140-2-2-140HA03-HP358	30801235
11,50	12	102	55	40	45	SCD600-1150-2-2-140HA03-HP358	30801237
11,60	12	102	55	40	45	SCD600-1160-2-2-140HA03-HP358	30801238
11,70	12	102	55	40	45	SCD600-1170-2-2-140HA03-HP358	30801239
11,80	12	102	55	40	45	SCD600-1180-2-2-140HA03-HP358	30801240
11,90	12	102	55	40	45	SCD600-1190-2-2-140HA03-HP358	30801241
12,00	12	102	55	40	45	SCD600-1200-2-2-140HA03-HP358	30801242
12,15	14	107	60	43	45	SCD600-1215-2-2-140HA03-HP358	30801243
12,25	14	107	60	43	45	SCD600-1225-2-2-140HA03-HP358	30801244
12,50	14	107	60	43	45	SCD600-1250-2-2-140HA03-HP358	30801245
12,55	14	107	60	43	45	SCD600-1255-2-2-140HA03-HP358	30801246
12,70	14	107	60	43	45	SCD600-1270-2-2-140HA03-HP358	30801247
12,80	14	107	60	43	45	SCD600-1280-2-2-140HA03-HP358	30801248
13,00	14	107	60	43	45	SCD600-1300-2-2-140HA03-HP358	30801250
13,10	14	107	60	43	45	SCD600-1310-2-2-140HA03-HP358	30801251
13,30	14	107	60	43	45	SCD600-1330-2-2-140HA03-HP358	30801252
13,35	14	107	60	43	45	SCD600-1335-2-2-140HA03-HP358	30801253
13,50	14	107	60	43	45	SCD600-1350-2-2-140HA03-HP358	30801254
13,70	14	107	60	43	45	SCD600-1370-2-2-140HA03-HP358	30801255
13,80	14	107	60	43	45	SCD600-1380-2-2-140HA03-HP358	30801256
14,00	14	107	60	43	45	SCD600-1400-2-2-140HA03-HP358	30801257
14,20	16	115	65	45	48	SCD600-1420-2-2-140HA03-HP358	30801258
14,50	16	115	65	45	48	SCD600-1450-2-2-140HA03-HP358	30801259
14,80	16	115	65	45	48	SCD600-1480-2-2-140HA03-HP358	30801260
15,00	16	115	65	45	48	SCD600-1500-2-2-140HA03-HP358	30801261
15,10	16	115	65	45	48	SCD600-1510-2-2-140HA03-HP358	30801262
15,25	16	115	65	45	48	SCD600-1525-2-2-140HA03-HP358	30801263
15,30	16	115	65	45	48	SCD600-1530-2-2-140HA03-HP358	30801264
15,35	16	115	65	45	48	SCD600-1535-2-2-140HA03-HP358	30801265
15,50	16	115	65	45	48	SCD600-1550-2-2-140HA03-HP358	30801266
15,60	16	115	65	45	48	SCD600-1560-2-2-140HA03-HP358	30801267
15,80	16	115	65	45	48	SCD600-1580-2-2-140HA03-HP358	30801268
16,00	16	115	65	45	48	SCD600-1600-2-2-140HA03-HP358	30801269
16,05	18	123	73	51	48	SCD600-1605-2-2-140HA03-HP358	30801270
16,50	18	123	73	51	48	SCD600-1650-2-2-140HA03-HP358	30801271
16,80	18	123	73	51	48	SCD600-1680-2-2-140HA03-HP358	30801272
17,00	18	123	73	51	48	SCD600-1700-2-2-140HA03-HP358	30801274
17,50	18	123	73	51	48	SCD600-1750-2-2-140HA03-HP358	30801275
17,80	18	123	73	51	48	SCD600-1780-2-2-140HA03-HP358	30801277
18,00	18	123	73	51	48	SCD600-1800-2-2-140HA03-HP358	30801278
18,50	20	131	79	55	50	SCD600-1850-2-2-140HA03-HP358	30801279
19,00	20	131	79	55	50	SCD600-1900-2-2-140HA03-HP358	30801282
19,35	20	131	79	55	50	SCD600-1935-2-2-140HA03-HP358	30801283
19,60	20	131	79	55	50	SCD600-1960-2-2-140HA03-HP358	30801285
19,80	20	131	79	55	50	SCD600-1980-2-2-140HA03-HP358	30801286
20,00	20	131	79	55	50	SCD600-2000-2-2-140HA03-HP358	30801287

Continued on next page.

MEGA-Drill-Steel-Plus | Solid carbide twist drill SCD600 (3xD), external coolant supply

Configurable features



Diameter:
Diameter in increments of
0.01 mm freely selectable



Shank form:
Shank form: HB | HE

Specification:

SCD600-[diameter]-3-3-140[shank form]03-HP358

Example:

SCD600-0431-3-3-140HE03-HP358

Shank form HE

Tool diameter $d_1 = 4.31$ mm

Dimensions of configurable series

d_1 min.	d_1 max.	d_2 h6	l_1	l_2	l_3	l_4
3,00	3,70	6	62	20	14	36
3,71	4,70	6	66	24	17	36
4,71	6,00	6	66	28	20	36
6,01	7,00	8	79	34	24	36
7,01	8,00	8	79	41	29	36
8,01	10,00	10	89	47	35	40
10,01	12,00	12	102	55	40	45
12,01	14,00	14	107	60	43	45
14,01	16,00	16	115	65	45	48
16,01	18,00	18	123	73	51	48
18,01	20,00	20	131	79	55	50
20,01	22,00	25	151	93	66	56
22,01	25,00	25	153	96	72	56

Dimensions in mm.

* Particularly suitable for the premanufacturing of core holes for thread formers.

For cutting data recommendations, see end of chapter.

Special designs and other coatings available upon request.

MEGA-Drill-Steel-Plus

Solid carbide twist drill

SCD601 (3xD), internal coolant supply, follow-up product to the MEGA-Drill-Steel (SCD10)

Design:

Drill diameter: 3.00 - 25.00 mm
 Bore tolerance: \geq IT 9
 Cutting material: HP358
 Number of cutting edges: 2
 Number of guiding chamfers: 2
 Tip angle: 140°
 Helix angle: 30°

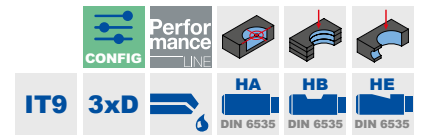
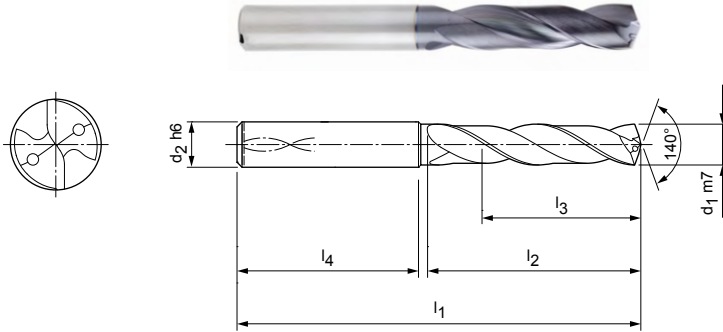

Stocked preferred series in shank form HA

Dimensions						Shank form HA	
d ₁ m7	d ₂ h6	l ₁	l ₂	l ₃	l ₄	Specification	Order no.
3,00	6	62	20	14	36	SCD601-0300-2-2-140HA03-HP358	30802107
3,10	6	62	20	14	36	SCD601-0310-2-2-140HA03-HP358	30802108
3,15	6	62	20	14	36	SCD601-0315-2-2-140HA03-HP358	30802109
3,20	6	62	20	14	36	SCD601-0320-2-2-140HA03-HP358	30802110
3,22	6	62	20	14	36	SCD601-0322-2-2-140HA03-HP358	30802111
3,25	6	62	20	14	36	SCD601-0325-2-2-140HA03-HP358	30802112
3,30	6	62	20	14	36	SCD601-0330-2-2-140HA03-HP358	30802113
3,40	6	62	20	14	36	SCD601-0340-2-2-140HA03-HP358	30802115
3,50	6	62	20	14	36	SCD601-0350-2-2-140HA03-HP358	30802116
3,60	6	62	20	14	36	SCD601-0360-2-2-140HA03-HP358	30802117
3,70*	6	62	20	14	36	SCD601-0370-2-2-140HA03-HP358	30802118
3,80	6	66	24	17	36	SCD601-0380-2-2-140HA03-HP358	30802119
3,85	6	66	24	17	36	SCD601-0385-2-2-140HA03-HP358	30802120
3,90	6	66	24	17	36	SCD601-0390-2-2-140HA03-HP358	30802121
4,00	6	66	24	17	36	SCD601-0400-2-2-140HA03-HP358	30802122
4,10	6	66	24	17	36	SCD601-0410-2-2-140HA03-HP358	30802123
4,20	6	66	24	17	36	SCD601-0420-2-2-140HA03-HP358	30802124
4,25	6	66	24	17	36	SCD601-0425-2-2-140HA03-HP358	30802125
4,30	6	66	24	17	36	SCD601-0430-2-2-140HA03-HP358	30802126
4,40	6	66	24	17	36	SCD601-0440-2-2-140HA03-HP358	30802129
4,50	6	66	24	17	36	SCD601-0450-2-2-140HA03-HP358	30802131
4,60	6	66	24	17	36	SCD601-0460-2-2-140HA03-HP358	30802132
4,65*	6	66	24	17	36	SCD601-0465-2-2-140HA03-HP358	30802133
4,70	6	66	24	17	36	SCD601-0470-2-2-140HA03-HP358	30802134
4,80	6	66	28	20	36	SCD601-0480-2-2-140HA03-HP358	30802135
4,90	6	66	28	20	36	SCD601-0490-2-2-140HA03-HP358	30802136
4,95	6	66	28	20	36	SCD601-0495-2-2-140HA03-HP358	30802137
5,00	6	66	28	20	36	SCD601-0500-2-2-140HA03-HP358	30802138
5,05	6	66	28	20	36	SCD601-0505-2-2-140HA03-HP358	30802139
5,10	6	66	28	20	36	SCD601-0510-2-2-140HA03-HP358	30802140
5,20	6	66	28	20	36	SCD601-0520-2-2-140HA03-HP358	30802141
5,30	6	66	28	20	36	SCD601-0530-2-2-140HA03-HP358	30802142
5,40	6	66	28	20	36	SCD601-0540-2-2-140HA03-HP358	30802143
5,50	6	66	28	20	36	SCD601-0550-2-2-140HA03-HP358	30802144
5,55*	6	66	28	20	36	SCD601-0555-2-2-140HA03-HP358	30802145

MEGA-Drill-Steel-Plus | Solid carbide twist drill SCD601 (3xD), internal coolant supply

Dimensions						Shank form HA	
d ₁ m7	d ₂ h6	l ₁	l ₂	l ₃	l ₄	Specification	Order no.
5,60	6	66	28	20	36	SCD601-0560-2-2-140HA03-HP358	30802146
5,70	6	66	28	20	36	SCD601-0570-2-2-140HA03-HP358	30802147
5,75	6	66	28	20	36	SCD601-0575-2-2-140HA03-HP358	30802148
5,80	6	66	28	20	36	SCD601-0580-2-2-140HA03-HP358	30802149
5,90	6	66	28	20	36	SCD601-0590-2-2-140HA03-HP358	30802150
5,95	6	66	28	20	36	SCD601-0595-2-2-140HA03-HP358	30802151
6,00	6	66	28	20	36	SCD601-0600-2-2-140HA03-HP358	30802152
6,10	8	79	34	24	36	SCD601-0610-2-2-140HA03-HP358	30802153
6,20	8	79	34	24	36	SCD601-0620-2-2-140HA03-HP358	30802154
6,30	8	79	34	24	36	SCD601-0630-2-2-140HA03-HP358	30802155
6,40	8	79	34	24	36	SCD601-0640-2-2-140HA03-HP358	30802156
6,50	8	79	34	24	36	SCD601-0650-2-2-140HA03-HP358	30802157
6,60	8	79	34	24	36	SCD601-0660-2-2-140HA03-HP358	30802158
6,70	8	79	34	24	36	SCD601-0670-2-2-140HA03-HP358	30802159
6,80	8	79	34	24	36	SCD601-0680-2-2-140HA03-HP358	30802160
6,90	8	79	34	24	36	SCD601-0690-2-2-140HA03-HP358	30802161
7,00	8	79	34	24	36	SCD601-0700-2-2-140HA03-HP358	30802162
7,10	8	79	41	29	36	SCD601-0710-2-2-140HA03-HP358	30802163
7,20	8	79	41	29	36	SCD601-0720-2-2-140HA03-HP358	30802164
7,30	8	79	41	29	36	SCD601-0730-2-2-140HA03-HP358	30802165
7,40	8	79	41	29	36	SCD601-0740-2-2-140HA03-HP358	30802166
7,45*	8	79	41	29	36	SCD601-0745-2-2-140HA03-HP358	30802167
7,50	8	79	41	29	36	SCD601-0750-2-2-140HA03-HP358	30802168
7,60	8	79	41	29	36	SCD601-0760-2-2-140HA03-HP358	30802169
7,70	8	79	41	29	36	SCD601-0770-2-2-140HA03-HP358	30802170
7,80	8	79	41	29	36	SCD601-0780-2-2-140HA03-HP358	30802171
7,90	8	79	41	29	36	SCD601-0790-2-2-140HA03-HP358	30802172
8,00	8	79	41	29	36	SCD601-0800-2-2-140HA03-HP358	30802173
8,10	10	89	47	35	40	SCD601-0810-2-2-140HA03-HP358	30802174
8,20	10	89	47	35	40	SCD601-0820-2-2-140HA03-HP358	30802175
8,30	10	89	47	35	40	SCD601-0830-2-2-140HA03-HP358	30802176
8,40	10	89	47	35	40	SCD601-0840-2-2-140HA03-HP358	30802177
8,50	10	89	47	35	40	SCD601-0850-2-2-140HA03-HP358	30802178
8,60	10	89	47	35	40	SCD601-0860-2-2-140HA03-HP358	30802179
8,70	10	89	47	35	40	SCD601-0870-2-2-140HA03-HP358	30802180
8,80	10	89	47	35	40	SCD601-0880-2-2-140HA03-HP358	30802181
8,90	10	89	47	35	40	SCD601-0890-2-2-140HA03-HP358	30802182
9,00	10	89	47	35	40	SCD601-0900-2-2-140HA03-HP358	30802183
9,10	10	89	47	35	40	SCD601-0910-2-2-140HA03-HP358	30802184
9,20	10	89	47	35	40	SCD601-0920-2-2-140HA03-HP358	30802185
9,30*	10	89	47	35	40	SCD601-0930-2-2-140HA03-HP358	30802186
9,35	10	89	47	35	40	SCD601-0935-2-2-140HA03-HP358	30802187
9,40	10	89	47	35	40	SCD601-0940-2-2-140HA03-HP358	30802188
9,50	10	89	47	35	40	SCD601-0950-2-2-140HA03-HP358	30802190
9,60	10	89	47	35	40	SCD601-0960-2-2-140HA03-HP358	30802191
9,70	10	89	47	35	40	SCD601-0970-2-2-140HA03-HP358	30802192
9,80	10	89	47	35	40	SCD601-0980-2-2-140HA03-HP358	30802193
9,90	10	89	47	35	40	SCD601-0990-2-2-140HA03-HP358	30802194
10,00	10	89	47	35	40	SCD601-1000-2-2-140HA03-HP358	30802195
10,10	12	102	55	40	45	SCD601-1010-2-2-140HA03-HP358	30802196
10,20	12	102	55	40	45	SCD601-1020-2-2-140HA03-HP358	30802197
10,30	12	102	55	40	45	SCD601-1030-2-2-140HA03-HP358	30802198
10,40	12	102	55	40	45	SCD601-1040-2-2-140HA03-HP358	30802199
10,50	12	102	55	40	45	SCD601-1050-2-2-140HA03-HP358	30802200
10,55	12	102	55	40	45	SCD601-1055-2-2-140HA03-HP358	30802201
10,60	12	102	55	40	45	SCD601-1060-2-2-140HA03-HP358	30802202
10,70	12	102	55	40	45	SCD601-1070-2-2-140HA03-HP358	30802203

MEGA-Drill-Steel-Plus | Solid carbide twist drill SCD601 (3xD), internal coolant supply

Dimensions						Shank form HA	
d ₁ m7	d ₂ h6	l ₁	l ₂	l ₃	l ₄	Specification	Order no.
10,75	12	102	55	40	45	SCD601-1075-2-2-140HA03-HP358	30802204
10,80	12	102	55	40	45	SCD601-1080-2-2-140HA03-HP358	30802205
10,90	12	102	55	40	45	SCD601-1090-2-2-140HA03-HP358	30802206
11,00	12	102	55	40	45	SCD601-1100-2-2-140HA03-HP358	30802207
11,10	12	102	55	40	45	SCD601-1110-2-2-140HA03-HP358	30802208
11,20*	12	102	55	40	45	SCD601-1120-2-2-140HA03-HP358	30802209
11,25	12	102	55	40	45	SCD601-1125-2-2-140HA03-HP358	30802210
11,30	12	102	55	40	45	SCD601-1130-2-2-140HA03-HP358	30802211
11,45	12	102	55	40	45	SCD601-1145-2-2-140HA03-HP358	30802214
11,50	12	102	55	40	45	SCD601-1150-2-2-140HA03-HP358	30802215
11,60	12	102	55	40	45	SCD601-1160-2-2-140HA03-HP358	30802216
11,70	12	102	55	40	45	SCD601-1170-2-2-140HA03-HP358	30802217
11,80	12	102	55	40	45	SCD601-1180-2-2-140HA03-HP358	30802218
11,90	12	102	55	40	45	SCD601-1190-2-2-140HA03-HP358	30802219
12,00	12	102	55	40	45	SCD601-1200-2-2-140HA03-HP358	30802220
12,15	14	107	60	43	45	SCD601-1215-2-2-140HA03-HP358	30802221
12,20	14	107	60	43	45	SCD601-1220-2-2-140HA03-HP358	31307544
12,25	14	107	60	43	45	SCD601-1225-2-2-140HA03-HP358	30802222
12,50	14	107	60	43	45	SCD601-1250-2-2-140HA03-HP358	30802223
12,55	14	107	60	43	45	SCD601-1255-2-2-140HA03-HP358	30802224
12,70	14	107	60	43	45	SCD601-1270-2-2-140HA03-HP358	30802225
12,80	14	107	60	43	45	SCD601-1280-2-2-140HA03-HP358	30802226
12,90	14	107	60	43	45	SCD601-1290-2-2-140HA03-HP358	30802227
13,00	14	107	60	43	45	SCD601-1300-2-2-140HA03-HP358	30802228
13,10	14	107	60	43	45	SCD601-1310-2-2-140HA03-HP358	30802229
13,30	14	107	60	43	45	SCD601-1330-2-2-140HA03-HP358	30802230
13,35	14	107	60	43	45	SCD601-1335-2-2-140HA03-HP358	30802231
13,50	14	107	60	43	45	SCD601-1350-2-2-140HA03-HP358	30802232
13,70	14	107	60	43	45	SCD601-1370-2-2-140HA03-HP358	30802233
13,80	14	107	60	43	45	SCD601-1380-2-2-140HA03-HP358	30802234
14,00	14	107	60	43	45	SCD601-1400-2-2-140HA03-HP358	30802235
14,20	16	115	65	45	48	SCD601-1420-2-2-140HA03-HP358	30802236
14,50	16	115	65	45	48	SCD601-1450-2-2-140HA03-HP358	30802237
14,80	16	115	65	45	48	SCD601-1480-2-2-140HA03-HP358	30802238
15,00	16	115	65	45	48	SCD601-1500-2-2-140HA03-HP358	30802239
15,10	16	115	65	45	48	SCD601-1510-2-2-140HA03-HP358	30802240
15,25	16	115	65	45	48	SCD601-1525-2-2-140HA03-HP358	30802241
15,30	16	115	65	45	48	SCD601-1530-2-2-140HA03-HP358	30802242
15,35	16	115	65	45	48	SCD601-1535-2-2-140HA03-HP358	30802243
15,50	16	115	65	45	48	SCD601-1550-2-2-140HA03-HP358	30802244
15,60	16	115	65	45	48	SCD601-1560-2-2-140HA03-HP358	30802245
15,80	16	115	65	45	48	SCD601-1580-2-2-140HA03-HP358	30802246
16,00	16	115	65	45	48	SCD601-1600-2-2-140HA03-HP358	30802247
16,05	18	123	73	51	48	SCD601-1605-2-2-140HA03-HP358	30802248
16,50	18	123	73	51	48	SCD601-1650-2-2-140HA03-HP358	30802249
16,60	18	123	73	51	48	SCD601-1660-2-2-140HA03-HP358	31307545
16,90	18	123	73	51	48	SCD601-1690-2-2-140HA03-HP358	30802251
17,00	18	123	73	51	48	SCD601-1700-2-2-140HA03-HP358	30802252
17,50	18	123	73	51	48	SCD601-1750-2-2-140HA03-HP358	30802253
17,60	18	123	73	51	48	SCD601-1760-2-2-140HA03-HP358	30802254
17,80	18	123	73	51	48	SCD601-1780-2-2-140HA03-HP358	30802255
18,00	18	123	73	51	48	SCD601-1800-2-2-140HA03-HP358	30802256
18,50	20	131	79	55	50	SCD601-1850-2-2-140HA03-HP358	30802257
18,90	20	131	79	55	50	SCD601-1890-2-2-140HA03-HP358	30802259
19,00	20	131	79	55	50	SCD601-1900-2-2-140HA03-HP358	30802260
19,35	20	131	79	55	50	SCD601-1935-2-2-140HA03-HP358	30802261
19,50	20	131	79	55	50	SCD601-1950-2-2-140HA03-HP358	30802262

Continued on next page.

MEGA-Drill-Steel-Plus | Solid carbide twist drill SCD601 (3xD), internal coolant supply

Dimensions						Shank form HA	
d ₁ m7	d ₂ h6	l ₁	l ₂	l ₃	l ₄	Specification	Order no.
19,80	20	131	79	55	50	SCD601-1980-2-2-140HA03-HP358	30802264
20,00	20	131	79	55	50	SCD601-2000-2-2-140HA03-HP358	30802265
21,00	25	151	93	66	56	SCD601-2100-2-2-140HA03-HP358	30802267
21,50	25	151	93	66	56	SCD601-2150-2-2-140HA03-HP358	30802268
22,00	25	151	93	66	56	SCD601-2200-2-2-140HA03-HP358	30802269
23,50	25	151	93	66	56	SCD601-2350-2-2-140HA03-HP358	30802272

Configurable features



Diameter:
Diameter in increments of
0.01 mm freely selectable



Shank form:
Shank form: HB | HE

Specification:

SCD601-[diameter]-3-3-140[shank form]03-HP358

Example:

SCD601-0431-3-3-140HE03-HP358

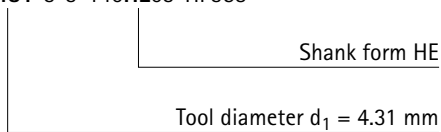

Dimensions of configurable series

d ₁ min.	d ₁ max.	d ₂ h6	l ₁	l ₂	l ₃	l ₄
3,00	3,70	6	62	20	14	36
3,71	4,70	6	66	24	17	36
4,71	6,00	6	66	28	20	36
6,01	7,00	8	79	34	24	36
7,01	8,00	8	79	41	29	36
8,01	10,00	10	89	47	35	40
10,01	12,00	12	102	55	40	45
12,01	14,00	14	107	60	43	45
14,01	16,00	16	115	65	45	48
16,01	18,00	18	123	73	51	48
18,01	20,00	20	131	79	55	50
20,01	25,00	25	151	93	66	56

Dimensions in mm.

* Particularly suitable for the premanufacturing of core holes for thread formers.

For cutting data recommendations, see end of chapter.

Special designs and other coatings available upon request.

MEGA-Drill-Steel-Plus

Solid carbide twist drill

SCD601 (5xD), internal coolant supply, follow-up product to the MEGA-Drill-Steel (SCD10)

Design:

- Drill diameter: 3.00 - 25.00 mm
- Bore tolerance: \geq IT 9
- Cutting material: HP358
- Number of cutting edges: 2
- Number of guiding chamfers: 2
- Tip angle: 140°
- Helix angle: 30°

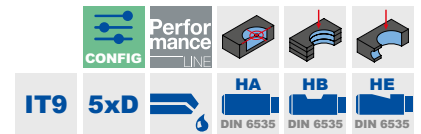
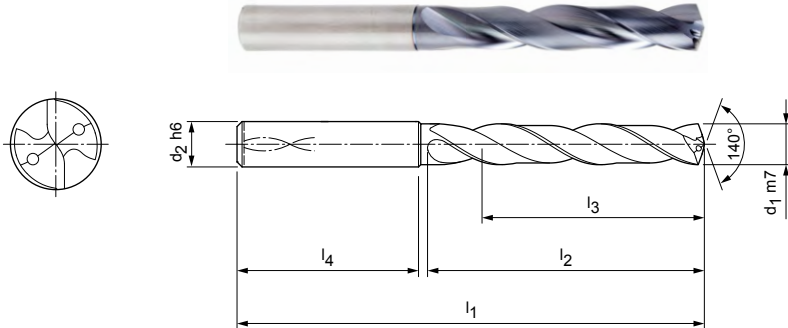

Stocked preferred series in shank form HA

Dimensions						Shank form HA	
d ₁ m7	d ₂ h6	l ₁	l ₂	l ₃	l ₄	Specification	Order no.
3,00	6	66	28	23	36	SCD601-0300-2-2-140HA05-HP358	30802611
3,10	6	66	28	23	36	SCD601-0310-2-2-140HA05-HP358	30802612
3,15	6	66	28	23	36	SCD601-0315-2-2-140HA05-HP358	30802613
3,20	6	66	28	23	36	SCD601-0320-2-2-140HA05-HP358	30802614
3,25	6	66	28	23	36	SCD601-0325-2-2-140HA05-HP358	30802616
3,30	6	66	28	23	36	SCD601-0330-2-2-140HA05-HP358	30802617
3,40	6	66	28	23	36	SCD601-0340-2-2-140HA05-HP358	30802618
3,50	6	66	28	23	36	SCD601-0350-2-2-140HA05-HP358	30802619
3,60	6	66	28	23	36	SCD601-0360-2-2-140HA05-HP358	30802620
3,65	6	66	28	23	36	SCD601-0365-2-2-140HA05-HP358	31307546
3,70*	6	66	28	23	36	SCD601-0370-2-2-140HA05-HP358	30802621
3,80	6	74	36	29	36	SCD601-0380-2-2-140HA05-HP358	30802622
3,85	6	74	36	29	36	SCD601-0385-2-2-140HA05-HP358	30802623
3,90	6	74	36	29	36	SCD601-0390-2-2-140HA05-HP358	30802624
4,00	6	74	36	29	36	SCD601-0400-2-2-140HA05-HP358	30802625
4,10	6	74	36	29	36	SCD601-0410-2-2-140HA05-HP358	30802626
4,20	6	74	36	29	36	SCD601-0420-2-2-140HA05-HP358	30802627
4,25	6	74	36	29	36	SCD601-0425-2-2-140HA05-HP358	30802628
4,30	6	74	36	29	36	SCD601-0430-2-2-140HA05-HP358	30802629
4,35	6	74	36	29	36	SCD601-0435-2-2-140HA05-HP358	30802630
4,40	6	74	36	29	36	SCD601-0440-2-2-140HA05-HP358	30802631
4,45	6	74	36	29	36	SCD601-0445-2-2-140HA05-HP358	30802632
4,50	6	74	36	29	36	SCD601-0450-2-2-140HA05-HP358	30802633
4,60	6	74	36	29	36	SCD601-0460-2-2-140HA05-HP358	30802634
4,65*	6	74	36	29	36	SCD601-0465-2-2-140HA05-HP358	30802635
4,70	6	74	36	29	36	SCD601-0470-2-2-140HA05-HP358	30802636
4,80	6	82	44	35	36	SCD601-0480-2-2-140HA05-HP358	30802637
4,90	6	82	44	35	36	SCD601-0490-2-2-140HA05-HP358	30802638
4,95	6	82	44	35	36	SCD601-0495-2-2-140HA05-HP358	30802639
5,00	6	82	44	35	36	SCD601-0500-2-2-140HA05-HP358	30802640
5,05	6	82	44	35	36	SCD601-0505-2-2-140HA05-HP358	30802641
5,10	6	82	44	35	36	SCD601-0510-2-2-140HA05-HP358	30802642
5,20	6	82	44	35	36	SCD601-0520-2-2-140HA05-HP358	30802643
5,30	6	82	44	35	36	SCD601-0530-2-2-140HA05-HP358	30802644
5,40	6	82	44	35	36	SCD601-0540-2-2-140HA05-HP358	30802645

MEGA-Drill-Steel-Plus | Solid carbide twist drill SCD601 (5xD), internal coolant supply

Dimensions						Shank form HA	
d ₁ m7	d ₂ h6	l ₁	l ₂	l ₃	l ₄	Specification	Order no.
5,50	6	82	44	35	36	SCD601-0550-2-2-140HA05-HP358	30802646
5,55*	6	82	44	35	36	SCD601-0555-2-2-140HA05-HP358	30802647
5,60	6	82	44	35	36	SCD601-0560-2-2-140HA05-HP358	30802648
5,70	6	82	44	35	36	SCD601-0570-2-2-140HA05-HP358	30802649
5,75	6	82	44	35	36	SCD601-0575-2-2-140HA05-HP358	30802650
5,80	6	82	44	35	36	SCD601-0580-2-2-140HA05-HP358	30802651
5,90	6	82	44	35	36	SCD601-0590-2-2-140HA05-HP358	30802652
5,95	6	82	44	35	36	SCD601-0595-2-2-140HA05-HP358	30802653
6,00	6	82	44	35	36	SCD601-0600-2-2-140HA05-HP358	30802654
6,10	8	91	53	43	36	SCD601-0610-2-2-140HA05-HP358	30802655
6,20	8	91	53	43	36	SCD601-0620-2-2-140HA05-HP358	30802656
6,30	8	91	53	43	36	SCD601-0630-2-2-140HA05-HP358	30802657
6,40	8	91	53	43	36	SCD601-0640-2-2-140HA05-HP358	30802658
6,50	8	91	53	43	36	SCD601-0650-2-2-140HA05-HP358	30802659
6,60	8	91	53	43	36	SCD601-0660-2-2-140HA05-HP358	30802660
6,70	8	91	53	43	36	SCD601-0670-2-2-140HA05-HP358	30802661
6,80	8	91	53	43	36	SCD601-0680-2-2-140HA05-HP358	30802662
6,90	8	91	53	43	36	SCD601-0690-2-2-140HA05-HP358	30802663
7,00	8	91	53	43	36	SCD601-0700-2-2-140HA05-HP358	30802664
7,10	8	91	53	43	36	SCD601-0710-2-2-140HA05-HP358	30802665
7,20	8	91	53	43	36	SCD601-0720-2-2-140HA05-HP358	30802666
7,30	8	91	53	43	36	SCD601-0730-2-2-140HA05-HP358	30802667
7,40	8	91	53	43	36	SCD601-0740-2-2-140HA05-HP358	30802668
7,45*	8	91	53	43	36	SCD601-0745-2-2-140HA05-HP358	30802669
7,50	8	91	53	43	36	SCD601-0750-2-2-140HA05-HP358	30802670
7,60	8	91	53	43	36	SCD601-0760-2-2-140HA05-HP358	30802671
7,70	8	91	53	43	36	SCD601-0770-2-2-140HA05-HP358	30802672
7,80	8	91	53	43	36	SCD601-0780-2-2-140HA05-HP358	30802673
7,90	8	91	53	43	36	SCD601-0790-2-2-140HA05-HP358	30802674
8,00	8	91	53	43	36	SCD601-0800-2-2-140HA05-HP358	30802675
8,10	10	103	61	49	40	SCD601-0810-2-2-140HA05-HP358	30802676
8,20	10	103	61	49	40	SCD601-0820-2-2-140HA05-HP358	30802677
8,30	10	103	61	49	40	SCD601-0830-2-2-140HA05-HP358	30802678
8,40	10	103	61	49	40	SCD601-0840-2-2-140HA05-HP358	30802679
8,50	10	103	61	49	40	SCD601-0850-2-2-140HA05-HP358	30802680
8,60	10	103	61	49	40	SCD601-0860-2-2-140HA05-HP358	30802681
8,70	10	103	61	49	40	SCD601-0870-2-2-140HA05-HP358	30802682
8,80	10	103	61	49	40	SCD601-0880-2-2-140HA05-HP358	30802683
8,90	10	103	61	49	40	SCD601-0890-2-2-140HA05-HP358	30802684
9,00	10	103	61	49	40	SCD601-0900-2-2-140HA05-HP358	30802685
9,10	10	103	61	49	40	SCD601-0910-2-2-140HA05-HP358	30802686
9,20	10	103	61	49	40	SCD601-0920-2-2-140HA05-HP358	30802687
9,30*	10	103	61	49	40	SCD601-0930-2-2-140HA05-HP358	30802688
9,35	10	103	61	49	40	SCD601-0935-2-2-140HA05-HP358	30802689
9,40	10	103	61	49	40	SCD601-0940-2-2-140HA05-HP358	30802690
9,45	10	103	61	49	40	SCD601-0945-2-2-140HA05-HP358	30802691
9,50	10	103	61	49	40	SCD601-0950-2-2-140HA05-HP358	30802692
9,60	10	103	61	49	40	SCD601-0960-2-2-140HA05-HP358	30802693
9,70	10	103	61	49	40	SCD601-0970-2-2-140HA05-HP358	30802694
9,80	10	103	61	49	40	SCD601-0980-2-2-140HA05-HP358	30802695
9,90	10	103	61	49	40	SCD601-0990-2-2-140HA05-HP358	30802696
10,00	10	103	61	49	40	SCD601-1000-2-2-140HA05-HP358	30802697
10,10	12	118	71	56	45	SCD601-1010-2-2-140HA05-HP358	30802698
10,20	12	118	71	56	45	SCD601-1020-2-2-140HA05-HP358	30802699
10,30	12	118	71	56	45	SCD601-1030-2-2-140HA05-HP358	30802700
10,40	12	118	71	56	45	SCD601-1040-2-2-140HA05-HP358	30802701
10,50	12	118	71	56	45	SCD601-1050-2-2-140HA05-HP358	30802702

MEGA-Drill-Steel-Plus | Solid carbide twist drill SCD601 (5xD), internal coolant supply

Dimensions						Shank form HA	
d ₁ m7	d ₂ h6	l ₁	l ₂	l ₃	l ₄	Specification	Order no.
10,55	12	118	71	56	45	SCD601-1055-2-2-140HA05-HP358	30802703
10,60	12	118	71	56	45	SCD601-1060-2-2-140HA05-HP358	30802704
10,70	12	118	71	56	45	SCD601-1070-2-2-140HA05-HP358	30802705
10,80	12	118	71	56	45	SCD601-1080-2-2-140HA05-HP358	30802707
10,90	12	118	71	56	45	SCD601-1090-2-2-140HA05-HP358	30802708
11,00	12	118	71	56	45	SCD601-1100-2-2-140HA05-HP358	30802709
11,10	12	118	71	56	45	SCD601-1110-2-2-140HA05-HP358	30802710
11,20*	12	118	71	56	45	SCD601-1120-2-2-140HA05-HP358	30802711
11,25	12	118	71	56	45	SCD601-1125-2-2-140HA05-HP358	30802712
11,30	12	118	71	56	45	SCD601-1130-2-2-140HA05-HP358	30802713
11,40	12	118	71	56	45	SCD601-1140-2-2-140HA05-HP358	30802715
11,50	12	118	71	56	45	SCD601-1150-2-2-140HA05-HP358	30802717
11,60	12	118	71	56	45	SCD601-1160-2-2-140HA05-HP358	30802718
11,70	12	118	71	56	45	SCD601-1170-2-2-140HA05-HP358	30802719
11,80	12	118	71	56	45	SCD601-1180-2-2-140HA05-HP358	30802720
11,90	12	118	71	56	45	SCD601-1190-2-2-140HA05-HP358	30802721
12,00	12	118	71	56	45	SCD601-1200-2-2-140HA05-HP358	30802722
12,15	14	124	77	60	45	SCD601-1215-2-2-140HA05-HP358	30802723
12,25	14	124	77	60	45	SCD601-1225-2-2-140HA05-HP358	30802724
12,30	14	124	77	60	45	SCD601-1230-2-2-140HA05-HP358	31201193
12,50	14	124	77	60	45	SCD601-1250-2-2-140HA05-HP358	30802725
12,55	14	124	77	60	45	SCD601-1255-2-2-140HA05-HP358	30802726
12,70	14	124	77	60	45	SCD601-1270-2-2-140HA05-HP358	30802727
12,80	14	124	77	60	45	SCD601-1280-2-2-140HA05-HP358	30802728
12,90	14	124	77	60	45	SCD601-1290-2-2-140HA05-HP358	30802729
13,00	14	124	77	60	45	SCD601-1300-2-2-140HA05-HP358	30802730
13,10	14	124	77	60	45	SCD601-1310-2-2-140HA05-HP358	30802731
13,30	14	124	77	60	45	SCD601-1330-2-2-140HA05-HP358	30802732
13,35	14	124	77	60	45	SCD601-1335-2-2-140HA05-HP358	30802733
13,50	14	124	77	60	45	SCD601-1350-2-2-140HA05-HP358	30802734
13,70	14	124	77	60	45	SCD601-1370-2-2-140HA05-HP358	30802735
13,80	14	124	77	60	45	SCD601-1380-2-2-140HA05-HP358	30802736
14,00	14	124	77	60	45	SCD601-1400-2-2-140HA05-HP358	30802737
14,20	16	133	83	63	48	SCD601-1420-2-2-140HA05-HP358	30802738
14,50	16	133	83	63	48	SCD601-1450-2-2-140HA05-HP358	30802739
14,80	16	133	83	63	48	SCD601-1480-2-2-140HA05-HP358	30802740
15,00	16	133	83	63	48	SCD601-1500-2-2-140HA05-HP358	30802741
15,10	16	133	83	63	48	SCD601-1510-2-2-140HA05-HP358	30802742
15,25	16	133	83	63	48	SCD601-1525-2-2-140HA05-HP358	30802743
15,30	16	133	83	63	48	SCD601-1530-2-2-140HA05-HP358	30802744
15,35	16	133	83	63	48	SCD601-1535-2-2-140HA05-HP358	30802745
15,50	16	133	83	63	48	SCD601-1550-2-2-140HA05-HP358	30802746
15,60	16	133	83	63	48	SCD601-1560-2-2-140HA05-HP358	30802747
15,80	16	133	83	63	48	SCD601-1580-2-2-140HA05-HP358	30802748
16,00	16	133	83	63	48	SCD601-1600-2-2-140HA05-HP358	30802749
16,05	18	143	93	71	48	SCD601-1605-2-2-140HA05-HP358	30802750
16,50	18	143	93	71	48	SCD601-1650-2-2-140HA05-HP358	30802751
16,80	18	143	93	71	48	SCD601-1680-2-2-140HA05-HP358	30802752
16,90	18	143	93	71	48	SCD601-1690-2-2-140HA05-HP358	30802753
17,00	18	143	93	71	48	SCD601-1700-2-2-140HA05-HP358	30802754

Continued on next page.

MEGA-Drill-Steel-Plus | Solid carbide twist drill SCD601 (5xD), internal coolant supply

Configurable features

**Diameter:**

Diameter in increments of 0.01 mm freely selectable

**Shank form:**

Shank form: HB | HE

Specification:

SCD601-[diameter]-3-3-140[shank form]05-HP358

Example:

SCD601-0431-3-3-140HE05-HP358

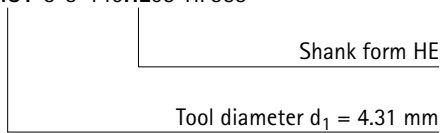

Dimensions of configurable series

d ₁ min.	d ₁ max.	d ₂ h6	l ₁	l ₂	l ₃	l ₄
3,00	3,70	6	66	28	23	36
3,71	4,70	6	74	36	29	36
4,71	6,00	6	82	44	35	36
6,01	8,00	8	91	53	43	36
8,01	10,00	10	103	61	49	40
10,01	12,00	12	118	71	56	45
12,01	14,00	14	124	77	60	45
14,01	16,00	16	133	83	63	48
16,01	18,00	18	143	93	71	48
18,01	20,00	20	153	101	77	50
20,01	22,00	25	200	135	110	56
22,01	25,00	25	200	140	120	56

Dimensions in mm.

* Particularly suitable for the premanufacturing of core holes for thread formers.

For cutting data recommendations, see end of chapter.

Special designs and other coatings available upon request.

MEGA-Drill-Steel-Plus

Solid carbide twist drill

SCD601 (8xD), internal coolant supply, follow-up product to the MEGA-Drill-Steel (SCD10)

Design:

Drill diameter: 3.00 - 20.00 mm
 Bore tolerance: \geq IT 9
 Cutting material: HP358
 Number of cutting edges: 2
 Number of guiding chamfers: 2
 Tip angle: 135°
 Helix angle: 30°

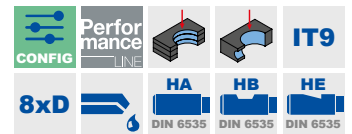
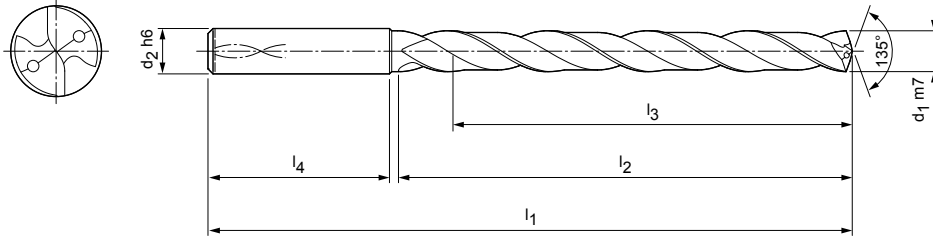

Stocked preferred series in shank form HA

Dimensions						Shank form HA	
d ₁ m7	d ₂ h6	l ₁	l ₂	l ₃	l ₄	Specification	Order no.
3,00	6	72	34	29	36	SCD601-0300-2-2-140HA08-HP358	30803112
3,10	6	72	34	29	36	SCD601-0310-2-2-140HA08-HP358	30803113
3,20	6	72	34	29	36	SCD601-0320-2-2-140HA08-HP358	30803114
3,30	6	72	34	29	36	SCD601-0330-2-2-140HA08-HP358	30803115
3,40	6	72	34	29	36	SCD601-0340-2-2-140HA08-HP358	30803116
3,50	6	72	34	29	36	SCD601-0350-2-2-140HA08-HP358	30803117
3,60	6	72	34	29	36	SCD601-0360-2-2-140HA08-HP358	30803118
3,70	6	72	34	29	36	SCD601-0370-2-2-140HA08-HP358	30803119
3,80	6	81	43	36	36	SCD601-0380-2-2-140HA08-HP358	30803120
3,90	6	81	43	36	36	SCD601-0390-2-2-140HA08-HP358	30803121
4,00	6	81	43	36	36	SCD601-0400-2-2-140HA08-HP358	30803122
4,10	6	81	43	36	36	SCD601-0410-2-2-140HA08-HP358	30803123
4,20	6	81	43	36	36	SCD601-0420-2-2-140HA08-HP358	30803124
4,30	6	81	43	36	36	SCD601-0430-2-2-140HA08-HP358	30803125
4,40	6	81	43	36	36	SCD601-0440-2-2-140HA08-HP358	30803126
4,50	6	81	43	36	36	SCD601-0450-2-2-140HA08-HP358	30803127
4,60	6	81	43	36	36	SCD601-0460-2-2-140HA08-HP358	30803128
4,70	6	81	43	36	36	SCD601-0470-2-2-140HA08-HP358	30803129
4,80	6	95	57	48	36	SCD601-0480-2-2-140HA08-HP358	30803130
4,90	6	95	57	48	36	SCD601-0490-2-2-140HA08-HP358	30803131
5,00	6	95	57	48	36	SCD601-0500-2-2-140HA08-HP358	30803132
5,10	6	95	57	48	36	SCD601-0510-2-2-140HA08-HP358	30803133
5,20	6	95	57	48	36	SCD601-0520-2-2-140HA08-HP358	30803134
5,30	6	95	57	48	36	SCD601-0530-2-2-140HA08-HP358	30803135
5,40	6	95	57	48	36	SCD601-0540-2-2-140HA08-HP358	30803136
5,50	6	95	57	48	36	SCD601-0550-2-2-140HA08-HP358	30803137
5,60	6	95	57	48	36	SCD601-0560-2-2-140HA08-HP358	30803138
5,70	6	95	57	48	36	SCD601-0570-2-2-140HA08-HP358	30803139
5,80	6	95	57	48	36	SCD601-0580-2-2-140HA08-HP358	30803140
5,90	6	95	57	48	36	SCD601-0590-2-2-140HA08-HP358	30803141
6,00	6	95	57	48	36	SCD601-0600-2-2-140HA08-HP358	30803142
6,10	8	114	76	64	36	SCD601-0610-2-2-140HA08-HP358	30803143
6,20	8	114	76	64	36	SCD601-0620-2-2-140HA08-HP358	30803144
6,30	8	114	76	64	36	SCD601-0630-2-2-140HA08-HP358	30803145
6,40	8	114	76	64	36	SCD601-0640-2-2-140HA08-HP358	30803146

MEGA-Drill-Steel-Plus | Solid carbide twist drill SCD601 (8xD), internal coolant supply

Dimensions						Shank form HA	
d ₁ m7	d ₂ h6	l ₁	l ₂	l ₃	l ₄	Specification	Order no.
6,50	8	114	76	64	36	SCD601-0650-2-2-140HA08-HP358	30803147
6,60	8	114	76	64	36	SCD601-0660-2-2-140HA08-HP358	30803148
6,70	8	114	76	64	36	SCD601-0670-2-2-140HA08-HP358	30803149
6,80	8	114	76	64	36	SCD601-0680-2-2-140HA08-HP358	30803150
6,90	8	114	76	64	36	SCD601-0690-2-2-140HA08-HP358	30803151
7,00	8	114	76	64	36	SCD601-0700-2-2-140HA08-HP358	30803152
7,10	8	114	76	64	36	SCD601-0710-2-2-140HA08-HP358	30803153
7,20	8	114	76	64	36	SCD601-0720-2-2-140HA08-HP358	30803154
7,30	8	114	76	64	36	SCD601-0730-2-2-140HA08-HP358	30803155
7,40	8	114	76	64	36	SCD601-0740-2-2-140HA08-HP358	30803156
7,50	8	114	76	64	36	SCD601-0750-2-2-140HA08-HP358	30803157
7,60	8	114	76	64	36	SCD601-0760-2-2-140HA08-HP358	30803158
7,70	8	114	76	64	36	SCD601-0770-2-2-140HA08-HP358	30803159
7,80	8	114	76	64	36	SCD601-0780-2-2-140HA08-HP358	30803160
7,90	8	114	76	64	36	SCD601-0790-2-2-140HA08-HP358	30803161
8,00	8	114	76	64	36	SCD601-0800-2-2-140HA08-HP358	30803162
8,10	10	142	95	80	40	SCD601-0810-2-2-140HA08-HP358	30803163
8,20	10	142	95	80	40	SCD601-0820-2-2-140HA08-HP358	30803164
8,40	10	142	95	80	40	SCD601-0840-2-2-140HA08-HP358	30803166
8,50	10	142	95	80	40	SCD601-0850-2-2-140HA08-HP358	30803167
8,60	10	142	95	80	40	SCD601-0860-2-2-140HA08-HP358	30803168
8,70	10	142	95	80	40	SCD601-0870-2-2-140HA08-HP358	30803169
8,80	10	142	95	80	40	SCD601-0880-2-2-140HA08-HP358	30803170
8,90	10	142	95	80	40	SCD601-0890-2-2-140HA08-HP358	30803171
9,00	10	142	95	80	40	SCD601-0900-2-2-140HA08-HP358	30803172
9,10	10	142	95	80	40	SCD601-0910-2-2-140HA08-HP358	30803173
9,20	10	142	95	80	40	SCD601-0920-2-2-140HA08-HP358	30803174
9,30	10	142	95	80	40	SCD601-0930-2-2-140HA08-HP358	30803175
9,40	10	142	95	80	40	SCD601-0940-2-2-140HA08-HP358	30803176
9,50	10	142	95	80	40	SCD601-0950-2-2-140HA08-HP358	30803177
9,60	10	142	95	80	40	SCD601-0960-2-2-140HA08-HP358	30803178
9,80	10	142	95	80	40	SCD601-0980-2-2-140HA08-HP358	30803180
9,90	10	142	95	80	40	SCD601-0990-2-2-140HA08-HP358	30803181
10,00	10	142	95	80	40	SCD601-1000-2-2-140HA08-HP358	30803182
10,10	12	162	114	96	45	SCD601-1010-2-2-140HA08-HP358	30803183
10,20	12	162	114	96	45	SCD601-1020-2-2-140HA08-HP358	30803184
10,30	12	162	114	95	45	SCD601-1030-2-2-140HA08-HP358	30803185
10,40	12	162	114	96	45	SCD601-1040-2-2-140HA08-HP358	30803186
10,50	12	162	114	96	45	SCD601-1050-2-2-140HA08-HP358	30803187
10,70	12	162	114	96	45	SCD601-1070-2-2-140HA08-HP358	30803189
10,80	12	162	114	96	45	SCD601-1080-2-2-140HA08-HP358	30803190
11,00	12	162	114	96	45	SCD601-1100-2-2-140HA08-HP358	30803192
11,10	12	162	114	96	45	SCD601-1110-2-2-140HA08-HP358	30803193
11,20	12	162	114	96	45	SCD601-1120-2-2-140HA08-HP358	30803194
11,30	12	162	114	96	45	SCD601-1130-2-2-140HA08-HP358	30803195
11,40	12	162	114	96	45	SCD601-1140-2-2-140HA08-HP358	30803196
11,50	12	162	114	96	45	SCD601-1150-2-2-140HA08-HP358	30803197
11,80	12	162	114	96	45	SCD601-1180-2-2-140HA08-HP358	30803200
12,00	12	162	114	96	45	SCD601-1200-2-2-140HA08-HP358	30803202
12,50	14	178	133	112	45	SCD601-1250-2-2-140HA08-HP358	30803203
12,80	14	178	133	112	45	SCD601-1280-2-2-140HA08-HP358	30803204
13,00	14	178	133	112	45	SCD601-1300-2-2-140HA08-HP358	30803205
13,50	14	178	133	112	45	SCD601-1350-2-2-140HA08-HP358	30803206
13,80	14	178	133	112	45	SCD601-1380-2-2-140HA08-HP358	30803207
14,00	14	178	133	112	45	SCD601-1400-2-2-140HA08-HP358	30803208
14,50	16	203	152	128	48	SCD601-1450-2-2-140HA08-HP358	30803209
14,80	16	203	152	128	48	SCD601-1480-2-2-140HA08-HP358	30803210

MEGA-Drill-Steel-Plus | Solid carbide twist drill SCD601 (8xD), internal coolant supply

Dimensions						Shank form HA	
d ₁ m7	d ₂ h6	l ₁	l ₂	l ₃	l ₄	Specification	Order no.
15,00	16	203	152	128	48	SCD601-1500-2-2-140HA08-HP358	30803211
15,50	16	203	152	128	48	SCD601-1550-2-2-140HA08-HP358	30803212
15,80	16	203	152	128	48	SCD601-1580-2-2-140HA08-HP358	30803213
16,00	16	203	152	128	48	SCD601-1600-2-2-140HA08-HP358	30803214
17,00	18	222	171	144	48	SCD601-1700-2-2-140HA08-HP358	30803217
17,50	18	222	171	144	48	SCD601-1750-2-2-140HA08-HP358	30803218
17,80	18	222	171	144	48	SCD601-1780-2-2-140HA08-HP358	30803219
18,00	18	222	171	144	48	SCD601-1800-2-2-140HA08-HP358	30803220
18,50	20	243	190	160	50	SCD601-1850-2-2-140HA08-HP358	30803221
18,80	20	243	190	160	50	SCD601-1880-2-2-140HA08-HP358	30803222
19,50	20	243	190	160	50	SCD601-1950-2-2-140HA08-HP358	30803224
19,80	20	243	190	160	50	SCD601-1980-2-2-140HA08-HP358	30803225
20,00	20	243	190	160	50	SCD601-2000-2-2-140HA08-HP358	30803226

Configurable features



Diameter:
Diameter in increments of
0.01 mm freely selectable



Shank form:
Shank form: HB | HE

Specification:

SCD601-[diameter]-3-3-140[shank form]08-HP358

Dimensions of configurable series

d ₁ min.	d ₁ max.	d ₂ h6	l ₁	l ₂	l ₃	l ₄
3,00	3,70	6	72	34	29	36
3,71	4,70	6	81	43	36	36
4,71	6,00	6	95	57	48	36
6,01	8,00	8	114	76	64	36
8,01	10,00	10	142	95	80	40
10,01	12,00	12	162	114	96	45
12,01	14,00	14	178	133	112	45
14,01	16,00	16	203	152	128	48
16,01	18,00	18	222	171	144	48
18,01	20,00	20	243	190	160	50

Example:

SCD601-0431-3-3-140HE08-HP358

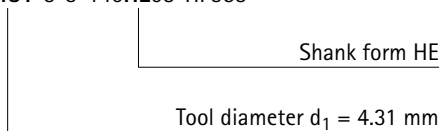

Dimensions in mm.

For cutting data recommendations, see end of chapter.

Special designs and other coatings available upon request.

MEGA-Drill-Hardened

Solid carbide twist drill
SCD140 (3xD)

Design:

Drill diameter: 2.55 – 20.00 mm
Bore tolerance: IT 9 (accessible)
Cutting material: HP809
Number of cutting edges: 2
Number of guiding chamfers: 2
Tip angle: 140°
Helix angle: 15°

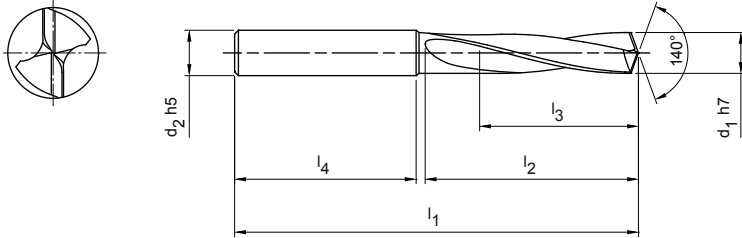

P
1
2
3
4
5
6
M
1
2
3
K
1
2
3
N
1
2
3
4
S
1
2
3
4
5
H
1
2
3

CONFIG

 Performance LINE

 IT9

3xD

 HA
DIN 6535

 HB
DIN 6535

 HE
DIN 6535

Stocked preferred series in shank form HA

Dimensions						Shank form HA	
d ₁ h7	d ₂ h5	l ₁	l ₂	l ₃	l ₄	Specification	Order no.
2,55	6	62	20	14	36	SCD140-0255-2-2-140HA03-HP809	31198190
2,60	6	62	20	14	36	SCD140-0260-2-2-140HA03-HP809	31198191
2,70	6	62	20	14	36	SCD140-0270-2-2-140HA03-HP809	31198192
2,80	6	62	20	14	36	SCD140-0280-2-2-140HA03-HP809	31198194
2,90	6	62	20	14	36	SCD140-0290-2-2-140HA03-HP809	31198196
3,00	6	62	20	14	36	SCD140-0300-2-2-140HA03-HP809	31151191
3,10	6	62	20	14	36	SCD140-0310-2-2-140HA03-HP809	31151192
3,20	6	62	20	14	36	SCD140-0320-2-2-140HA03-HP809	31151193
3,30	6	62	20	14	36	SCD140-0330-2-2-140HA03-HP809	31151194
3,40	6	62	20	14	36	SCD140-0340-2-2-140HA03-HP809	31151195
3,50	6	62	20	14	36	SCD140-0350-2-2-140HA03-HP809	31151196
3,60	6	62	20	14	36	SCD140-0360-2-2-140HA03-HP809	31151197
3,70	6	62	20	14	36	SCD140-0370-2-2-140HA03-HP809	31151198
3,80	6	66	24	17	36	SCD140-0380-2-2-140HA03-HP809	31151199
3,90	6	66	24	17	36	SCD140-0390-2-2-140HA03-HP809	31151330
4,00	6	66	24	17	36	SCD140-0400-2-2-140HA03-HP809	31151331
4,10	6	66	24	17	36	SCD140-0410-2-2-140HA03-HP809	31151332
4,20	6	66	24	17	36	SCD140-0420-2-2-140HA03-HP809	31151333
4,30	6	66	24	17	36	SCD140-0430-2-2-140HA03-HP809	31151334
4,40	6	66	24	17	36	SCD140-0440-2-2-140HA03-HP809	31151335
4,50	6	66	24	17	36	SCD140-0450-2-2-140HA03-HP809	31151336
4,60	6	66	24	17	36	SCD140-0460-2-2-140HA03-HP809	31151337
4,70	6	66	24	17	36	SCD140-0470-2-2-140HA03-HP809	31151339
4,80	6	66	28	20	36	SCD140-0480-2-2-140HA03-HP809	31151340
4,90	6	66	28	20	36	SCD140-0490-2-2-140HA03-HP809	31151341
5,00	6	66	28	20	36	SCD140-0500-2-2-140HA03-HP809	31151342
5,10	6	66	28	20	36	SCD140-0510-2-2-140HA03-HP809	31151343
5,20	6	66	28	20	36	SCD140-0520-2-2-140HA03-HP809	31151344
5,30	6	66	28	20	36	SCD140-0530-2-2-140HA03-HP809	31151345
5,40	6	66	28	20	36	SCD140-0540-2-2-140HA03-HP809	31151346
5,50	6	66	28	20	36	SCD140-0550-2-2-140HA03-HP809	31151347
5,55	6	66	28	20	36	SCD140-0555-2-2-140HA03-HP809	31151348
5,60	6	66	28	20	36	SCD140-0560-2-2-140HA03-HP809	31151349
5,70	6	66	28	20	36	SCD140-0570-2-2-140HA03-HP809	31151350
5,80	6	66	28	20	36	SCD140-0580-2-2-140HA03-HP809	31151351

MEGA-Drill-Hardened | Solid carbide twist drill SCD140 (3xD)

Dimensions						Shank form HA	
d ₁ h7	d ₂ h6	l ₁	l ₂	l ₃	l ₄	Specification	Order no.
5,90	6	66	28	20	36	SCD140-0590-2-2-140HA03-HP809	31151352
6,00	6	66	28	20	36	SCD140-0600-2-2-140HA03-HP809	31151353
6,10	8	79	34	24	36	SCD140-0610-2-2-140HA03-HP809	31151354
6,20	8	79	34	24	36	SCD140-0620-2-2-140HA03-HP809	31151355
6,30	8	79	34	24	36	SCD140-0630-2-2-140HA03-HP809	31151356
6,40	8	79	34	24	36	SCD140-0640-2-2-140HA03-HP809	31151357
6,50	8	79	34	24	36	SCD140-0650-2-2-140HA03-HP809	31151358
6,60	8	79	34	24	36	SCD140-0660-2-2-140HA03-HP809	31151359
6,70	8	79	34	24	36	SCD140-0670-2-2-140HA03-HP809	31151360
6,80	8	79	34	24	36	SCD140-0680-2-2-140HA03-HP809	31151361
6,90	8	79	34	24	36	SCD140-0690-2-2-140HA03-HP809	31151362
7,00	8	79	34	24	36	SCD140-0700-2-2-140HA03-HP809	31151363
7,10	8	79	41	29	36	SCD140-0710-2-2-140HA03-HP809	31151364
7,30	8	79	41	29	36	SCD140-0730-2-2-140HA03-HP809	31151366
7,40	8	79	41	29	36	SCD140-0740-2-2-140HA03-HP809	31151367
7,50	8	79	41	29	36	SCD140-0750-2-2-140HA03-HP809	31151368
7,80	8	79	41	29	36	SCD140-0780-2-2-140HA03-HP809	31151371
7,90	8	79	41	29	36	SCD140-0790-2-2-140HA03-HP809	31151372
8,00	8	79	41	29	36	SCD140-0800-2-2-140HA03-HP809	31151373
8,10	10	89	47	35	40	SCD140-0810-2-2-140HA03-HP809	31151374
8,20	10	89	47	35	40	SCD140-0820-2-2-140HA03-HP809	31151375
8,50	10	89	47	35	40	SCD140-0850-2-2-140HA03-HP809	31151378
8,60	10	89	47	35	40	SCD140-0860-2-2-140HA03-HP809	31151379
8,80	10	89	47	35	40	SCD140-0880-2-2-140HA03-HP809	31151381
9,00	10	89	47	35	40	SCD140-0900-2-2-140HA03-HP809	31151383
9,30	10	89	47	35	40	SCD140-0930-2-2-140HA03-HP809	31151386
9,50	10	89	47	35	40	SCD140-0950-2-2-140HA03-HP809	31151388
9,60	10	89	47	35	40	SCD140-0960-2-2-140HA03-HP809	31151389
9,70	10	89	47	35	40	SCD140-0970-2-2-140HA03-HP809	31151390
9,80	10	89	47	35	40	SCD140-0980-2-2-140HA03-HP809	31151391
10,00	10	89	47	35	40	SCD140-1000-2-2-140HA03-HP809	31151393
10,10	12	102	55	40	45	SCD140-1010-2-2-140HA03-HP809	31151394
10,20	12	102	55	40	45	SCD140-1020-2-2-140HA03-HP809	31151395
10,30	12	102	55	40	45	SCD140-1030-2-2-140HA03-HP809	31151396
10,40	12	102	55	40	45	SCD140-1040-2-2-140HA03-HP809	31151397
10,50	12	102	55	40	45	SCD140-1050-2-2-140HA03-HP809	31151398
11,00	12	102	55	40	45	SCD140-1100-2-2-140HA03-HP809	31151403
11,50	12	102	55	40	45	SCD140-1150-2-2-140HA03-HP809	31151408
11,80	12	102	55	40	45	SCD140-1180-2-2-140HA03-HP809	31151411
11,90	12	102	55	40	45	SCD140-1190-2-2-140HA03-HP809	31151412
12,00	12	102	55	40	45	SCD140-1200-2-2-140HA03-HP809	31151413
12,50	14	107	60	43	45	SCD140-1250-2-2-140HA03-HP809	31151415
12,80	14	107	60	43	45	SCD140-1280-2-2-140HA03-HP809	31151416
13,00	14	107	60	43	45	SCD140-1300-2-2-140HA03-HP809	31151417
13,50	14	107	60	43	45	SCD140-1350-2-2-140HA03-HP809	31151418
14,00	14	107	60	43	45	SCD140-1400-2-2-140HA03-HP809	31151420
14,20	16	115	65	45	48	SCD140-1420-2-2-140HA03-HP809	31151421
14,50	16	115	65	45	48	SCD140-1450-2-2-140HA03-HP809	31151422
14,80	16	115	65	45	48	SCD140-1480-2-2-140HA03-HP809	31151423
15,00	16	115	65	45	48	SCD140-1500-2-2-140HA03-HP809	31151424
15,50	16	115	65	45	48	SCD140-1550-2-2-140HA03-HP809	31151426
16,00	16	115	65	45	48	SCD140-1600-2-2-140HA03-HP809	31151428
17,50	18	123	73	51	48	SCD140-1750-2-2-140HA03-HP809	31151432

Continued on next page.

MEGA-Drill-Hardened | Solid carbide twist drill SCD140 (3xD)

Configurable features

**Diameter:**

Diameter in increments of
0.01 mm freely selectable

**Shank form:**

Shank form: HB | HE

Specification:

SCD140-[diameter]-2-2-140[shank form]03-HP809

Example:

SCD140-0431-2-2-140HE03-HP809

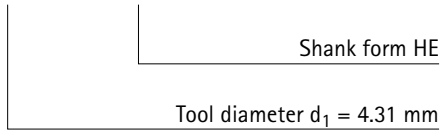

Dimensions of configurable series

d ₁ min.	d ₁ max.	d ₂ h6	l ₁	l ₂	l ₃	l ₄
2,55	3,79	6	62	20	14	36
3,80	4,79	6	66	24	17	36
4,80	6,00	6	66	28	20	36
6,01	7,00	8	79	34	24	36
7,01	8,00	8	79	41	29	36
8,01	10,00	10	89	47	35	40
10,01	12,00	12	102	55	40	45
12,01	14,00	14	107	60	43	45
14,01	16,00	16	115	65	45	48
16,01	18,00	18	123	73	51	48
18,01	20,00	20	131	79	55	50

Dimensions in mm.

For cutting data recommendations, see end of chapter.

Special designs and other coatings available upon request.

Tritan-Spot-Drill-Steel

Solid carbide NC-pilot drill
SCD670, external coolant supply

Design:

Drill diameter: 4.00 - 20.00 mm
Shank form: HA (DIN 6535)
Cutting material: HP358
Number of cutting edges: 3
Tip angle: 155°

Application:

Special NC pilot drill for the Tritan-Drill-Steel.

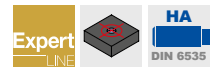
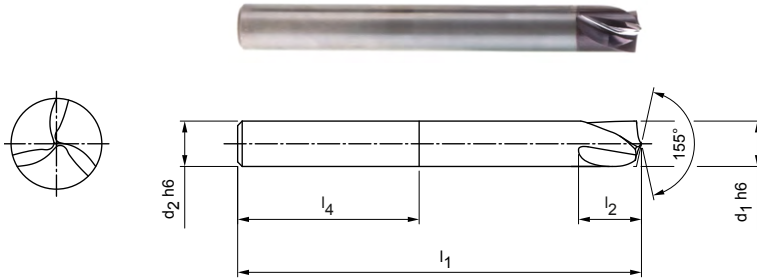

Preferred series in stock

Dimensions					Shank form HA	
d ₁ h6	d ₂ h6	l ₁	l ₂	l ₄	Specification	Order no.
4,00	4	55	6	28	SCD670-0400-3-0-155HA-HP358	30980587
5,00	6	62	7	36	SCD670-0500-3-0-155HA-HP358	30980588
6,00	6	66	9	36	SCD670-0600-3-0-155HA-HP358	30980589
8,00	8	79	11	36	SCD670-0800-3-0-155HA-HP358	30980590
10,00	10	89	14	40	SCD670-1000-3-0-155HA-HP358	30980592
12,00	12	102	17	45	SCD670-1200-3-0-155HA-HP358	30980594
16,00	16	115	23	48	SCD670-1600-3-0-155HA-HP358	30980595
20,00	20	131	28	50	SCD670-2000-3-0-155HA-HP358	30980596

Drilling depths

d ₁ h6	d ₂ h6	l ₁	l ₂	l ₄	Maximum drilling depth *	Minimum drilling depth **
4,00	4	55	6	28	0,40	0,24
5,00	6	62	7	36	0,50	0,30
6,00	6	66	9	36	0,60	0,36
8,00	8	79	11	36	0,80	0,48
10,00	10	89	14	40	1,00	0,60
12,00	12	102	17	45	1,20	0,72
16,00	16	115	23	48	1,60	0,96
20,00	20	131	28	50	2,00	1,20

* 10% from nominal Ø

** 6% from nominal Ø

Dimensions in mm.

For cutting data recommendations, see end of chapter.

Special designs and other coatings available upon request.

Tritan-Drill-Steel

Solid carbide twist drill
SCD661 (3xD), internal coolant supply

Design:
 Drill diameter: 4.00 - 20.00 mm
 Bore tolerance: ≥ IT 9
 Cutting material: HP358
 Number of cutting edges: 3
 Number of guiding chamfers: 3
 Tip angle: 145°
 Helix angle: 30°

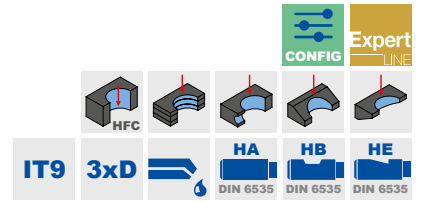
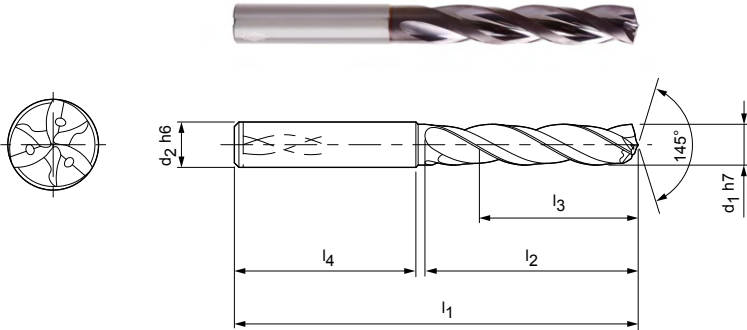

Stocked preferred series in shank form HA

Dimensions						Shank form HA	
$d_1 h7$	$d_2 h6$	l_1	l_2	l_3	l_4	Specification	Order no.
4,00	6	66	24	17	36	SCD661-0400-3-3-145HA03-HP358	30902036
4,10	6	66	24	17	36	SCD661-0410-3-3-145HA03-HP358	30902037
4,20	6	66	24	17	36	SCD661-0420-3-3-145HA03-HP358	30902038
4,30	6	66	24	17	36	SCD661-0430-3-3-145HA03-HP358	30902039
4,40	6	66	24	17	36	SCD661-0440-3-3-145HA03-HP358	30902040
4,50	6	66	24	17	36	SCD661-0450-3-3-145HA03-HP358	30902041
4,60	6	66	24	17	36	SCD661-0460-3-3-145HA03-HP358	30902042
4,65	6	66	24	17	36	SCD661-0465-3-3-145HA03-HP358	30902043
4,70	6	66	24	17	36	SCD661-0470-3-3-145HA03-HP358	30902044
4,80	6	66	28	20	36	SCD661-0480-3-3-145HA03-HP358	30902045
4,90	6	66	28	20	36	SCD661-0490-3-3-145HA03-HP358	30902046
5,00	6	66	28	20	36	SCD661-0500-3-3-145HA03-HP358	30902047
5,10	6	66	28	20	36	SCD661-0510-3-3-145HA03-HP358	30902048
5,20	6	66	28	20	36	SCD661-0520-3-3-145HA03-HP358	30902049
5,30	6	66	28	20	36	SCD661-0530-3-3-145HA03-HP358	30902050
5,40	6	66	28	20	36	SCD661-0540-3-3-145HA03-HP358	30902051
5,50	6	66	28	20	36	SCD661-0550-3-3-145HA03-HP358	30902052
5,55	6	66	28	20	36	SCD661-0555-3-3-145HA03-HP358	30902053
5,60	6	66	28	20	36	SCD661-0560-3-3-145HA03-HP358	30902054
5,70	6	66	28	20	36	SCD661-0570-3-3-145HA03-HP358	30902055
5,80	6	66	28	20	36	SCD661-0580-3-3-145HA03-HP358	30902056
5,90	6	66	28	20	36	SCD661-0590-3-3-145HA03-HP358	30902057
6,00	6	66	28	20	36	SCD661-0600-3-3-145HA03-HP358	30902058
6,10	8	79	34	24	36	SCD661-0610-3-3-145HA03-HP358	30902059
6,20	8	79	34	24	36	SCD661-0620-3-3-145HA03-HP358	30902060
6,30	8	79	34	24	36	SCD661-0630-3-3-145HA03-HP358	30902061
6,35	8	79	34	24	36	SCD661-0635-3-3-145HA03-HP358	31307522
6,40	8	79	34	24	36	SCD661-0640-3-3-145HA03-HP358	30902062
6,50	8	79	34	24	36	SCD661-0650-3-3-145HA03-HP358	30902063
6,60	8	79	34	24	36	SCD661-0660-3-3-145HA03-HP358	30902064
6,70	8	79	34	24	36	SCD661-0670-3-3-145HA03-HP358	30902065
6,80	8	79	34	24	36	SCD661-0680-3-3-145HA03-HP358	30902066
6,90	8	79	34	24	36	SCD661-0690-3-3-145HA03-HP358	30902067
7,00	8	79	34	24	36	SCD661-0700-3-3-145HA03-HP358	30902068
7,10	8	79	41	29	36	SCD661-0710-3-3-145HA03-HP358	30902069

Tritan-Drill-Steel | Solid carbide twist drill SCD661 (3xD), internal coolant supply

Dimensions						Shank form HA	
d ₁ h7	d ₂ h6	l ₁	l ₂	l ₃	l ₄	Specification	Order no.
7,20	8	79	41	29	36	SCD661-0720-3-3-145HA03-HP358	30902070
7,30	8	79	41	29	36	SCD661-0730-3-3-145HA03-HP358	30902071
7,40	8	79	41	29	36	SCD661-0740-3-3-145HA03-HP358	30902072
7,45	8	79	41	29	36	SCD661-0745-3-3-145HA03-HP358	30902073
7,50	8	79	41	29	36	SCD661-0750-3-3-145HA03-HP358	30902074
7,60	8	79	41	29	36	SCD661-0760-3-3-145HA03-HP358	30902075
7,70	8	79	41	29	36	SCD661-0770-3-3-145HA03-HP358	30902076
7,80	8	79	41	29	36	SCD661-0780-3-3-145HA03-HP358	30902077
7,90	8	79	41	29	36	SCD661-0790-3-3-145HA03-HP358	30902078
8,00	8	79	41	29	36	SCD661-0800-3-3-145HA03-HP358	30902079
8,10	10	89	47	35	40	SCD661-0810-3-3-145HA03-HP358	30902080
8,20	10	89	47	35	40	SCD661-0820-3-3-145HA03-HP358	30902081
8,30	10	89	47	35	40	SCD661-0830-3-3-145HA03-HP358	30902082
8,40	10	89	47	35	40	SCD661-0840-3-3-145HA03-HP358	30902083
8,50	10	89	47	35	40	SCD661-0850-3-3-145HA03-HP358	30902084
8,60	10	89	47	35	40	SCD661-0860-3-3-145HA03-HP358	30902085
8,70	10	89	47	35	40	SCD661-0870-3-3-145HA03-HP358	30902086
8,80	10	89	47	35	40	SCD661-0880-3-3-145HA03-HP358	30902087
9,00	10	89	47	35	40	SCD661-0900-3-3-145HA03-HP358	30902089
9,10	10	89	47	35	40	SCD661-0910-3-3-145HA03-HP358	30902090
9,20	10	89	47	35	40	SCD661-0920-3-3-145HA03-HP358	30902091
9,30	10	89	47	35	40	SCD661-0930-3-3-145HA03-HP358	30902092
9,35	10	89	47	35	40	SCD661-0935-3-3-145HA03-HP358	31307523
9,40	10	89	47	35	40	SCD661-0940-3-3-145HA03-HP358	30902093
9,50	10	89	47	35	40	SCD661-0950-3-3-145HA03-HP358	30902094
9,60	10	89	47	35	40	SCD661-0960-3-3-145HA03-HP358	30902095
9,70	10	89	47	35	40	SCD661-0970-3-3-145HA03-HP358	30902096
9,80	10	89	47	35	40	SCD661-0980-3-3-145HA03-HP358	30902097
9,90	10	89	47	35	40	SCD661-0990-3-3-145HA03-HP358	30902098
10,00	10	89	47	35	40	SCD661-1000-3-3-145HA03-HP358	30902099
10,10	12	102	55	40	45	SCD661-1010-3-3-145HA03-HP358	30902100
10,20	12	102	55	40	45	SCD661-1020-3-3-145HA03-HP358	30902101
10,30	12	102	55	40	45	SCD661-1030-3-3-145HA03-HP358	30902102
10,40	12	102	55	40	45	SCD661-1040-3-3-145HA03-HP358	30902103
10,50	12	102	55	40	45	SCD661-1050-3-3-145HA03-HP358	30902104
10,80	12	102	55	40	45	SCD661-1080-3-3-145HA03-HP358	30902107
10,90	12	102	55	40	45	SCD661-1090-3-3-145HA03-HP358	30902108
11,00	12	102	55	40	45	SCD661-1100-3-3-145HA03-HP358	30902109
11,10	12	102	55	40	45	SCD661-1110-3-3-145HA03-HP358	30902110
11,20	12	102	55	40	45	SCD661-1120-3-3-145HA03-HP358	30902111
11,30	12	102	55	40	45	SCD661-1130-3-3-145HA03-HP358	30902112
11,40	12	102	55	40	45	SCD661-1140-3-3-145HA03-HP358	30902113
11,50	12	102	55	40	45	SCD661-1150-3-3-145HA03-HP358	30902114
11,60	12	102	55	40	45	SCD661-1160-3-3-145HA03-HP358	30902115
11,70	12	102	55	40	45	SCD661-1170-3-3-145HA03-HP358	30902116
11,80	12	102	55	40	45	SCD661-1180-3-3-145HA03-HP358	30902117
11,90	12	102	55	40	45	SCD661-1190-3-3-145HA03-HP358	30902118
12,00	12	102	55	40	45	SCD661-1200-3-3-145HA03-HP358	30902119
12,20	14	107	60	43	45	SCD661-1220-3-3-145HA03-HP358	30902120
12,23	14	107	60	43	45	SCD661-1223-3-3-145HA03-HP358	31271441
12,50	14	107	60	43	45	SCD661-1250-3-3-145HA03-HP358	30902121
12,70	14	107	60	43	45	SCD661-1270-3-3-145HA03-HP358	31307524
13,00	14	107	60	43	45	SCD661-1300-3-3-145HA03-HP358	30902123
13,50	14	107	60	43	45	SCD661-1350-3-3-145HA03-HP358	30902125
13,80	14	107	60	43	45	SCD661-1380-3-3-145HA03-HP358	30902126
14,00	14	107	60	43	45	SCD661-1400-3-3-145HA03-HP358	30902127
14,20	16	115	65	45	48	SCD661-1420-3-3-145HA03-HP358	30902128

Continued on next page.

Tritan-Drill-Steel | Solid carbide twist drill SCD661 (3xD), internal coolant supply

Dimensions						Shank form HA	
d ₁ h7	d ₂ h6	l ₁	l ₂	l ₃	l ₄	Specification	Order no.
14,50	16	115	65	45	48	SCD661-1450-3-3-145HA03-HP358	30902129
14,80	16	115	65	45	48	SCD661-1480-3-3-145HA03-HP358	30902130
15,00	16	115	65	45	48	SCD661-1500-3-3-145HA03-HP358	30902131
15,20	16	115	65	45	48	SCD661-1520-3-3-145HA03-HP358	30902132
15,50	16	115	65	45	48	SCD661-1550-3-3-145HA03-HP358	30902133
15,80	16	115	65	45	48	SCD661-1580-3-3-145HA03-HP358	30902134
16,00	16	115	65	45	48	SCD661-1600-3-3-145HA03-HP358	30902135
16,20	18	123	73	51	48	SCD661-1620-3-3-145HA03-HP358	30902136
16,50	18	123	73	51	48	SCD661-1650-3-3-145HA03-HP358	30902137
17,00	18	123	73	51	48	SCD661-1700-3-3-145HA03-HP358	30902139
17,35	18	123	73	51	48	SCD661-1735-3-3-145HA03-HP358	31307525
17,50	18	123	73	51	48	SCD661-1750-3-3-145HA03-HP358	30902141
17,80	18	123	73	51	48	SCD661-1780-3-3-145HA03-HP358	30902142
18,00	18	123	73	51	48	SCD661-1800-3-3-145HA03-HP358	30902143
18,50	20	131	79	55	50	SCD661-1850-3-3-145HA03-HP358	30902145
18,80	20	131	79	55	50	SCD661-1880-3-3-145HA03-HP358	30902146
19,00	20	131	79	55	50	SCD661-1900-3-3-145HA03-HP358	30902147
19,50	20	131	79	55	50	SCD661-1950-3-3-145HA03-HP358	30902149
20,00	20	131	79	55	50	SCD661-2000-3-3-145HA03-HP358	30902151

Configurable features



Diameter:
Diameter in increments of
0.01 mm freely selectable



Shank form:
Shank form: HB | HE

Specification:

SCD661-[diameter]-3-3-140[shank form]03-HP358

Dimensions of configurable series

d ₁ min.	d ₁ max.	d ₂ h6	l ₁	l ₂	l ₃	l ₄
4,00	4,70	6	66	24	17	36
4,71	6,00	6	66	28	20	36
6,01	7,00	8	79	34	24	36
7,01	8,00	8	79	41	29	36
8,01	10,00	10	89	47	35	40
10,01	12,00	12	102	55	40	45
12,01	14,00	14	107	60	43	45
14,01	16,00	16	115	65	45	48
16,01	18,00	18	123	73	51	48
18,01	20,00	20	131	79	55	50

Example:

SCD661-0431-3-3-140HE03-HP358

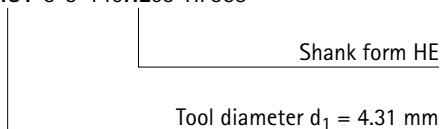

Dimensions in mm.

For cutting data recommendations, see end of chapter.

Special designs and other coatings available upon request.

Tritan-Drill-Steel

Solid carbide twist drill
SCD661 (5xD), internal coolant supply

Design:
 Drill diameter: 4.00 - 20.00 mm
 Bore tolerance: \geq IT 9
 Cutting material: HP358
 Number of cutting edges: 3
 Number of guiding chamfers: 3
 Tip angle: 145°
 Helix angle: 30°

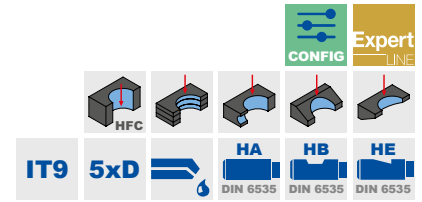
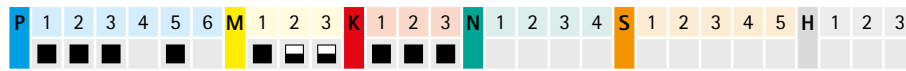
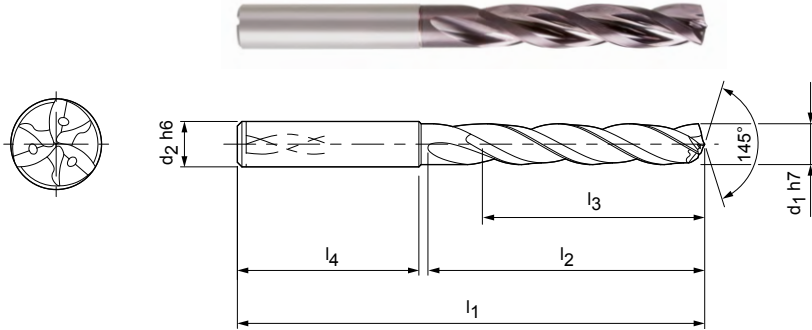

Stocked preferred series in shank form HA

Dimensions						Shank form HA	
d ₁ h7	d ₂ h6	l ₁	l ₂	l ₃	l ₄	Specification	Order no.
4,00	6	74	36	29	36	SCD661-0400-3-3-145HA05-HP358	30902152
4,10	6	74	36	29	36	SCD661-0410-3-3-145HA05-HP358	30902153
4,20	6	74	36	29	36	SCD661-0420-3-3-145HA05-HP358	30902154
4,30	6	74	36	29	36	SCD661-0430-3-3-145HA05-HP358	30902155
4,40	6	74	36	29	36	SCD661-0440-3-3-145HA05-HP358	30902156
4,50	6	74	36	29	36	SCD661-0450-3-3-145HA05-HP358	30902157
4,60	6	74	36	29	36	SCD661-0460-3-3-145HA05-HP358	30902158
4,65	6	74	36	29	36	SCD661-0465-3-3-145HA05-HP358	30902159
4,70	6	74	36	29	36	SCD661-0470-3-3-145HA05-HP358	30902160
4,80	6	82	44	35	36	SCD661-0480-3-3-145HA05-HP358	30902161
4,90	6	82	44	35	36	SCD661-0490-3-3-145HA05-HP358	30902162
5,00	6	82	44	35	36	SCD661-0500-3-3-145HA05-HP358	30902163
5,10	6	82	44	35	36	SCD661-0510-3-3-145HA05-HP358	30902164
5,20	6	82	44	35	36	SCD661-0520-3-3-145HA05-HP358	30902165
5,30	6	82	44	35	36	SCD661-0530-3-3-145HA05-HP358	30902166
5,40	6	82	44	35	36	SCD661-0540-3-3-145HA05-HP358	30902167
5,50	6	82	44	35	36	SCD661-0550-3-3-145HA05-HP358	30902168
5,55	6	82	44	35	36	SCD661-0555-3-3-145HA05-HP358	30902169
5,60	6	82	44	35	36	SCD661-0560-3-3-145HA05-HP358	30902170
5,70	6	82	44	35	36	SCD661-0570-3-3-145HA05-HP358	30902171
5,80	6	82	44	35	36	SCD661-0580-3-3-145HA05-HP358	30902172
5,90	6	82	44	35	36	SCD661-0590-3-3-145HA05-HP358	30902173
6,00	6	82	44	35	36	SCD661-0600-3-3-145HA05-HP358	30902174
6,05	8	91	53	43	36	SCD661-0605-3-3-145HA05-HP358	31307526
6,10	8	91	53	43	36	SCD661-0610-3-3-145HA05-HP358	30902175
6,20	8	91	53	43	36	SCD661-0620-3-3-145HA05-HP358	30902176
6,30	8	91	53	43	36	SCD661-0630-3-3-145HA05-HP358	30902177
6,40	8	91	53	43	36	SCD661-0640-3-3-145HA05-HP358	30902178
6,50	8	91	53	43	36	SCD661-0650-3-3-145HA05-HP358	30902179
6,60	8	91	53	43	36	SCD661-0660-3-3-145HA05-HP358	30902180
6,80	8	91	53	43	36	SCD661-0680-3-3-145HA05-HP358	30902182
6,90	8	91	53	43	36	SCD661-0690-3-3-145HA05-HP358	30902183
7,00	8	91	53	43	36	SCD661-0700-3-3-145HA05-HP358	30902184
7,10	8	91	53	43	36	SCD661-0710-3-3-145HA05-HP358	30902185
7,20	8	91	53	43	36	SCD661-0720-3-3-145HA05-HP358	30902186

Tritan-Drill-Steel | Solid carbide twist drill SCD661 (5xD), internal coolant supply

Dimensions						Shank form HA	
d ₁ h7	d ₂ h6	l ₁	l ₂	l ₃	l ₄	Specification	Order no.
7,30	8	91	53	43	36	SCD661-0730-3-3-145HA05-HP358	30902187
7,40	8	91	53	43	36	SCD661-0740-3-3-145HA05-HP358	30902188
7,45	8	91	53	43	36	SCD661-0745-3-3-145HA05-HP358	30902189
7,50	8	91	53	43	36	SCD661-0750-3-3-145HA05-HP358	30902190
7,60	8	91	53	43	36	SCD661-0760-3-3-145HA05-HP358	30902191
7,70	8	91	53	43	36	SCD661-0770-3-3-145HA05-HP358	30902192
7,80	8	91	53	43	36	SCD661-0780-3-3-145HA05-HP358	30902193
7,90	8	91	53	43	36	SCD661-0790-3-3-145HA05-HP358	30902194
8,00	8	91	53	43	36	SCD661-0800-3-3-145HA05-HP358	30902195
8,10	10	103	61	49	40	SCD661-0810-3-3-145HA05-HP358	30902196
8,20	10	103	61	49	40	SCD661-0820-3-3-145HA05-HP358	30902197
8,30	10	103	61	49	40	SCD661-0830-3-3-145HA05-HP358	30902198
8,40	10	103	61	49	40	SCD661-0840-3-3-145HA05-HP358	30902199
8,50	10	103	61	49	40	SCD661-0850-3-3-145HA05-HP358	30902200
8,60	10	103	61	49	40	SCD661-0860-3-3-145HA05-HP358	30902201
8,70	10	103	61	49	40	SCD661-0870-3-3-145HA05-HP358	30902202
8,80	10	103	61	49	40	SCD661-0880-3-3-145HA05-HP358	30902203
8,90	10	103	61	49	40	SCD661-0890-3-3-145HA05-HP358	30902204
9,00	10	103	61	49	40	SCD661-0900-3-3-145HA05-HP358	30902205
9,10	10	103	61	49	40	SCD661-0910-3-3-145HA05-HP358	30902206
9,20	10	103	61	49	40	SCD661-0920-3-3-145HA05-HP358	30902207
9,30	10	103	61	49	40	SCD661-0930-3-3-145HA05-HP358	30902208
9,35	10	103	61	49	40	SCD661-0935-3-3-145HA05-HP358	30902209
9,40	10	103	61	49	40	SCD661-0940-3-3-145HA05-HP358	30902210
9,50	10	103	61	49	40	SCD661-0950-3-3-145HA05-HP358	30902211
9,70	10	103	61	49	40	SCD661-0970-3-3-145HA05-HP358	30902214
9,80	10	103	61	49	40	SCD661-0980-3-3-145HA05-HP358	30902215
9,90	10	103	61	49	40	SCD661-0990-3-3-145HA05-HP358	30902216
10,00	10	103	61	49	40	SCD661-1000-3-3-145HA05-HP358	30902217
10,10	12	118	71	56	45	SCD661-1010-3-3-145HA05-HP358	30902218
10,20	12	118	71	56	45	SCD661-1020-3-3-145HA05-HP358	30902219
10,30	12	118	71	56	45	SCD661-1030-3-3-145HA05-HP358	30902220
10,40	12	118	71	56	45	SCD661-1040-3-3-145HA05-HP358	30902221
10,50	12	118	71	56	45	SCD661-1050-3-3-145HA05-HP358	30902222
10,80	12	118	71	56	45	SCD661-1080-3-3-145HA05-HP358	30902225
11,00	12	118	71	56	45	SCD661-1100-3-3-145HA05-HP358	30902227
11,10	12	118	71	56	45	SCD661-1110-3-3-145HA05-HP358	30902228
11,20	12	118	71	56	45	SCD661-1120-3-3-145HA05-HP358	30902229
11,30	12	118	71	56	45	SCD661-1130-3-3-145HA05-HP358	30902230
11,40	12	118	71	56	45	SCD661-1140-3-3-145HA05-HP358	30902231
11,50	12	118	71	56	45	SCD661-1150-3-3-145HA05-HP358	30902232
11,80	12	118	71	56	45	SCD661-1180-3-3-145HA05-HP358	30902235
11,90	12	118	71	56	45	SCD661-1190-3-3-145HA05-HP358	30902236
12,00	12	118	71	56	45	SCD661-1200-3-3-145HA05-HP358	30902237
12,20	14	124	77	60	45	SCD661-1220-3-3-145HA05-HP358	30902238
12,50	14	124	77	60	45	SCD661-1250-3-3-145HA05-HP358	30902239
12,80	14	124	77	60	45	SCD661-1280-3-3-145HA05-HP358	30902240
13,00	14	124	77	60	45	SCD661-1300-3-3-145HA05-HP358	30902241
13,50	14	124	77	60	45	SCD661-1350-3-3-145HA05-HP358	30902243
13,80	14	124	77	60	45	SCD661-1380-3-3-145HA05-HP358	30902244
14,00	14	124	77	60	45	SCD661-1400-3-3-145HA05-HP358	30902245
14,20	16	133	83	63	48	SCD661-1420-3-3-145HA05-HP358	30902246
14,50	16	133	83	63	48	SCD661-1450-3-3-145HA05-HP358	30902247
14,80	16	133	83	63	48	SCD661-1480-3-3-145HA05-HP358	30902248
15,00	16	133	83	63	48	SCD661-1500-3-3-145HA05-HP358	30902249
15,10	16	133	83	63	48	SCD661-1510-3-3-145HA05-HP358	30902250
15,20	16	133	83	63	48	SCD661-1520-3-3-145HA05-HP358	30902251

Tritan-Drill-Steel | Solid carbide twist drill SCD661 (5xD), internal coolant supply

Dimensions						Shank form HA	
d ₁ h7	d ₂ h6	l ₁	l ₂	l ₃	l ₄	Specification	Order no.
15,25	16	133	83	63	48	SCD661-1525-3-3-145HA05-HP358	30902252
15,50	16	133	83	63	48	SCD661-1550-3-3-145HA05-HP358	30902253
15,80	16	133	83	63	48	SCD661-1580-3-3-145HA05-HP358	30902254
16,00	16	133	83	63	48	SCD661-1600-3-3-145HA05-HP358	30902255
16,20	18	143	93	71	48	SCD661-1620-3-3-145HA05-HP358	30902256
16,50	18	143	93	71	48	SCD661-1650-3-3-145HA05-HP358	30902257
16,80	18	143	93	71	48	SCD661-1680-3-3-145HA05-HP358	30902258
17,00	18	143	93	71	48	SCD661-1700-3-3-145HA05-HP358	30902259
17,50	18	143	93	71	48	SCD661-1750-3-3-145HA05-HP358	30902261
18,00	18	143	93	71	48	SCD661-1800-3-3-145HA05-HP358	30902263
18,50	20	153	101	77	50	SCD661-1850-3-3-145HA05-HP358	30902265
18,80	20	153	101	77	50	SCD661-1880-3-3-145HA05-HP358	30902266
19,00	20	153	101	77	50	SCD661-1900-3-3-145HA05-HP358	30902267
19,50	20	153	101	77	50	SCD661-1950-3-3-145HA05-HP358	30902269
19,80	20	153	101	77	50	SCD661-1980-3-3-145HA05-HP358	30902270
20,00	20	153	101	77	50	SCD661-2000-3-3-145HA05-HP358	30902271

Configurable features

**Diameter:**

Diameter in increments of 0.01 mm freely selectable

**Shank form:**

Shank form: HB | HE

Specification:

SCD661-[diameter]-3-3-145[shank form]05-HP358

Dimensions of configurable series

d ₁ min.	d ₁ max.	d ₂ h6	l ₁	l ₂	l ₃	l ₄
4,00	4,70	6	74	36	29	36
4,71	6,00	6	82	44	35	36
6,01	8,00	8	91	53	43	36
8,01	10,00	10	103	61	49	40
10,01	12,00	12	118	71	56	45
12,01	14,00	14	124	77	60	45
14,01	16,00	16	133	83	63	48
16,01	18,00	18	143	93	71	48
18,01	20,00	20	153	101	77	50

Example:

SCD661-0431-3-3-145HE05-HP358

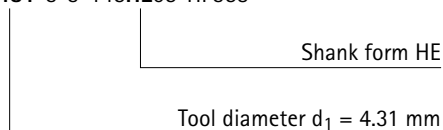

Dimensions in mm.

For cutting data recommendations, see end of chapter.

Special designs and other coatings available upon request.

Tritan-Drill-Steel

Solid carbide twist drill
SCD661 (8xD), internal coolant supply

Design:
 Drill diameter: 4.00 - 20.00 mm
 Bore tolerance: ≥ IT 9
 Cutting material: HP358
 Number of cutting edges: 3
 Number of guiding chamfers: 3
 Tip angle: 140°
 Helix angle: 30°

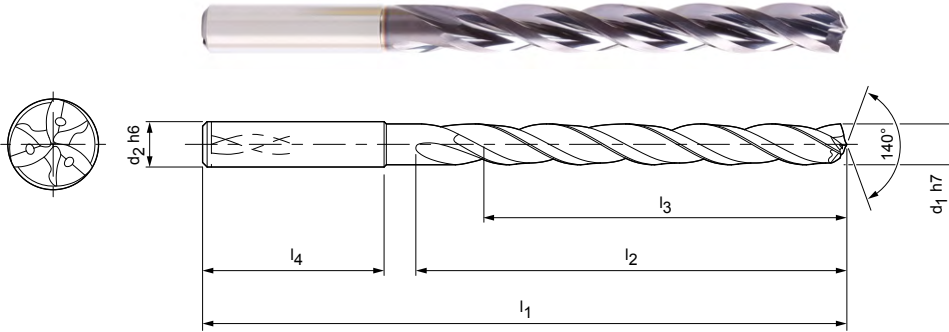

Note:
 To achieve optimum drilling results, MAPAL recommends the Tritan-Drill-Steel in combination with the Tritan-Spot-Drill-Steel.

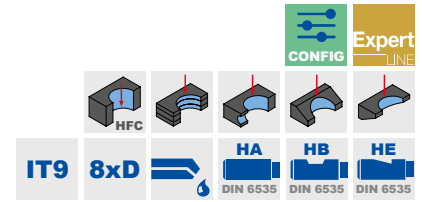

Stocked preferred series in shank form HA

Dimensions						Shank form HA	
d_1 h7	d_2 h6	l_1	l_2	l_3	l_4	Specification	Order no.
4,00	6	81	43	36	36	SCD661-0400-3-3-140HA08-HP358	30902272
4,10	6	81	43	36	36	SCD661-0410-3-3-140HA08-HP358	30902273
4,20	6	81	43	36	36	SCD661-0420-3-3-140HA08-HP358	30902274
4,30	6	81	43	36	36	SCD661-0430-3-3-140HA08-HP358	30902275
4,50	6	81	43	36	36	SCD661-0450-3-3-140HA08-HP358	30902277
4,60	6	81	43	36	36	SCD661-0460-3-3-140HA08-HP358	30902278
4,70	6	81	43	36	36	SCD661-0470-3-3-140HA08-HP358	30902279
4,80	6	95	57	48	36	SCD661-0480-3-3-140HA08-HP358	30902280
5,00	6	95	57	48	36	SCD661-0500-3-3-140HA08-HP358	30902282
5,10	6	95	57	48	36	SCD661-0510-3-3-140HA08-HP358	30902283
5,20	6	95	57	48	36	SCD661-0520-3-3-140HA08-HP358	30902284
5,40	6	95	57	48	36	SCD661-0540-3-3-140HA08-HP358	30902286
5,50	6	95	57	48	36	SCD661-0550-3-3-140HA08-HP358	30902287
5,60	6	95	57	48	36	SCD661-0560-3-3-140HA08-HP358	30902288
5,80	6	95	57	48	36	SCD661-0580-3-3-140HA08-HP358	30902290
5,90	6	95	57	48	36	SCD661-0590-3-3-140HA08-HP358	30902291
6,00	6	95	57	48	36	SCD661-0600-3-3-140HA08-HP358	30902292
6,10	8	114	76	64	36	SCD661-0610-3-3-140HA08-HP358	30902293
6,50	8	114	76	64	36	SCD661-0650-3-3-140HA08-HP358	30902297
6,60	8	114	76	64	36	SCD661-0660-3-3-140HA08-HP358	30902298
6,80	8	114	76	64	36	SCD661-0680-3-3-140HA08-HP358	30902300
6,90	8	114	76	64	36	SCD661-0690-3-3-140HA08-HP358	30902301
7,00	8	114	76	64	36	SCD661-0700-3-3-140HA08-HP358	30902302
7,50	8	114	76	64	36	SCD661-0750-3-3-140HA08-HP358	30902307
7,80	8	114	76	64	36	SCD661-0780-3-3-140HA08-HP358	30902310
7,90	8	114	76	64	36	SCD661-0790-3-3-140HA08-HP358	30902311
8,00	8	114	76	64	36	SCD661-0800-3-3-140HA08-HP358	30902312
8,10	10	142	95	80	40	SCD661-0810-3-3-140HA08-HP358	30902313
8,20	10	142	95	80	40	SCD661-0820-3-3-140HA08-HP358	30902314
8,50	10	142	95	80	40	SCD661-0850-3-3-140HA08-HP358	30902317
8,60	10	142	95	80	40	SCD661-0860-3-3-140HA08-HP358	30902318
8,80	10	142	95	80	40	SCD661-0880-3-3-140HA08-HP358	30902320
9,00	10	142	95	80	40	SCD661-0900-3-3-140HA08-HP358	30902322
9,10	10	142	95	80	40	SCD661-0910-3-3-140HA08-HP358	30902323
9,50	10	142	95	80	40	SCD661-0950-3-3-140HA08-HP358	30902327

Tritan-Drill-Steel | Solid carbide twist drill SCD661 (8xD), internal coolant supply

Dimensions						Shank form HA	
d ₁ h7	d ₂ h6	l ₁	l ₂	l ₃	l ₄	Specification	Order no.
9,80	10	142	95	80	40	SCD661-0980-3-3-140HA08-HP358	30902330
10,00	10	142	95	80	40	SCD661-1000-3-3-140HA08-HP358	30902332
10,20	12	162	114	96	45	SCD661-1020-3-3-140HA08-HP358	30902334
10,30	12	162	114	96	45	SCD661-1030-3-3-140HA08-HP358	30902335
10,50	12	162	114	96	45	SCD661-1050-3-3-140HA08-HP358	30902337
11,00	12	162	114	96	45	SCD661-1100-3-3-140HA08-HP358	30902342
11,50	12	162	114	96	45	SCD661-1150-3-3-140HA08-HP358	30902347
11,80	12	162	114	96	45	SCD661-1180-3-3-140HA08-HP358	30902350
11,90	12	162	114	96	45	SCD661-1190-3-3-140HA08-HP358	30902351
12,00	12	162	114	96	45	SCD661-1200-3-3-140HA08-HP358	30902352
12,20	14	178	133	112	45	SCD661-1220-3-3-140HA08-HP358	30902353
12,50	14	178	133	112	45	SCD661-1250-3-3-140HA08-HP358	30902354
13,00	14	178	133	112	45	SCD661-1300-3-3-140HA08-HP358	30902356
13,50	14	178	133	112	45	SCD661-1350-3-3-140HA08-HP358	30902358
13,80	14	178	133	112	45	SCD661-1380-3-3-140HA08-HP358	30902359
14,00	14	178	133	112	45	SCD661-1400-3-3-140HA08-HP358	30902360
14,20	16	203	152	128	48	SCD661-1420-3-3-140HA08-HP358	30902361
14,50	16	203	152	128	48	SCD661-1450-3-3-140HA08-HP358	30902362
15,00	16	203	152	128	48	SCD661-1500-3-3-140HA08-HP358	30902364
15,50	16	203	152	128	48	SCD661-1550-3-3-140HA08-HP358	30902366
15,80	16	203	152	128	48	SCD661-1580-3-3-140HA08-HP358	30902367
16,00	16	203	152	128	48	SCD661-1600-3-3-140HA08-HP358	30902368
17,00	18	222	171	144	48	SCD661-1700-3-3-140HA08-HP358	30902372
17,50	18	222	171	144	48	SCD661-1750-3-3-140HA08-HP358	30902374
18,00	18	222	171	144	48	SCD661-1800-3-3-140HA08-HP358	30902376
18,50	20	243	190	160	50	SCD661-1850-3-3-140HA08-HP358	30902378
19,00	20	243	190	160	50	SCD661-1900-3-3-140HA08-HP358	30902380
19,20	20	243	190	160	50	SCD661-1920-3-3-140HA08-HP358	30902381
19,50	20	243	190	160	50	SCD661-1950-3-3-140HA08-HP358	30902382
20,00	20	243	190	160	50	SCD661-2000-3-3-140HA08-HP358	30902384

Configurable features



Diameter:
Diameter in increments of
0.01 mm freely selectable



Shank form:
Shank form: HB | HE

Specification:

SCD661-[diameter]-3-3-140[shank form]08-HP358

Dimensions of configurable series

d ₁ min.	d ₁ max.	d ₂ h6	l ₁	l ₂	l ₃	l ₄
4,00	4,70	6	81	43	36	36
4,71	6,00	6	95	57	48	36
6,01	8,00	8	114	76	64	36
8,01	10,00	10	142	95	80	40
10,01	12,00	12	162	114	96	45
12,01	14,00	14	178	133	112	45
14,01	16,00	16	203	152	128	48
16,01	18,00	18	222	171	144	48
18,01	20,00	20	243	190	160	50

Example:

SCD661-0431-3-3-140HE08-HP358

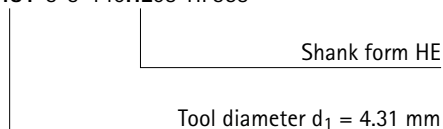

Dimensions in mm.

For cutting data recommendations, see end of chapter.

Special designs and other coatings available upon request.

Tritan-Drill-Steel

Solid carbide twist drill
SCD661 (12xD), internal coolant supply

Design:
 Drill diameter: 4.00 - 20.00 mm
 Bore tolerance: ≥ IT 9
 Cutting material: HP358
 Number of cutting edges: 3
 Number of guiding chamfers: 3
 Tip angle: 140°
 Helix angle: 30°

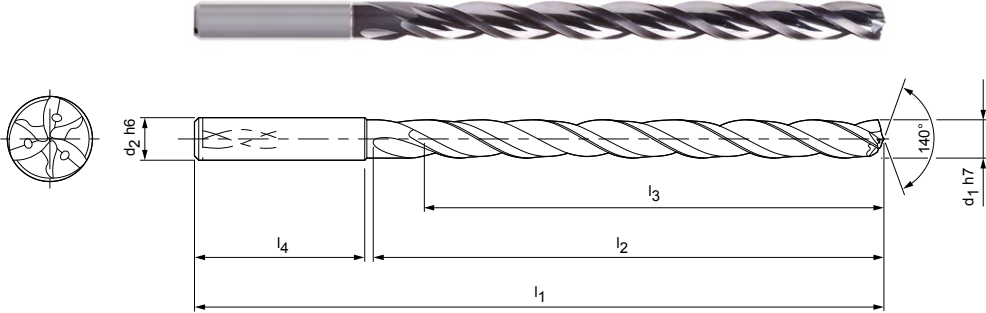

Note:
 To achieve optimum drilling results, MAPAL recommends the Tritan-Drill-Steel in combination with the Tritan-Spot-Drill-Steel.

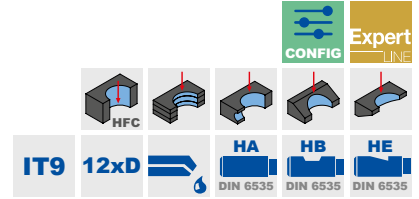

Stocked preferred series in shank form HA

Dimensions						Shank form HA	
d ₁ h7	d ₂ h6	l ₁	l ₂	l ₃	l ₄	Specification	Order no.
4,00	6	102	64	58	36	SCD661-0400-3-3-140HA12-HP358	30902385
4,10	6	102	64	58	36	SCD661-0410-3-3-140HA12-HP358	30902386
4,20	6	102	64	58	36	SCD661-0420-3-3-140HA12-HP358	30902387
4,30	6	102	64	58	36	SCD661-0430-3-3-140HA12-HP358	30902388
4,50	6	102	64	58	36	SCD661-0450-3-3-140HA12-HP358	30902390
4,60	6	102	64	58	36	SCD661-0460-3-3-140HA12-HP358	30902391
4,80	6	116	78	70	36	SCD661-0480-3-3-140HA12-HP358	30902393
5,00	6	116	78	70	36	SCD661-0500-3-3-140HA12-HP358	30902395
5,10	6	116	78	70	36	SCD661-0510-3-3-140HA12-HP358	30902396
5,20	6	116	78	70	36	SCD661-0520-3-3-140HA12-HP358	30902397
5,40	6	116	78	70	36	SCD661-0540-3-3-140HA12-HP358	30902399
5,50	6	116	78	70	36	SCD661-0550-3-3-140HA12-HP358	30902400
5,80	6	116	78	70	36	SCD661-0580-3-3-140HA12-HP358	30902403
5,90	6	116	78	70	36	SCD661-0590-3-3-140HA12-HP358	30902404
6,00	6	116	78	70	36	SCD661-0600-3-3-140HA12-HP358	30902405
6,10	8	146	108	94	36	SCD661-0610-3-3-140HA12-HP358	30902406
6,50	8	146	108	94	36	SCD661-0650-3-3-140HA12-HP358	30902410
6,80	8	146	108	94	36	SCD661-0680-3-3-140HA12-HP358	30902413
7,00	8	146	108	94	36	SCD661-0700-3-3-140HA12-HP358	30902415
7,50	8	146	108	94	36	SCD661-0750-3-3-140HA12-HP358	30902420
7,80	8	146	108	94	36	SCD661-0780-3-3-140HA12-HP358	30902423
7,90	8	146	108	94	36	SCD661-0790-3-3-140HA12-HP358	30902424
8,00	8	146	108	94	36	SCD661-0800-3-3-140HA12-HP358	30902425
8,20	10	162	120	110	40	SCD661-0820-3-3-140HA12-HP358	30902427
8,40	10	162	120	110	40	SCD661-0840-3-3-140HA12-HP358	30902429
8,50	10	162	120	110	40	SCD661-0850-3-3-140HA12-HP358	30902430
8,80	10	162	120	110	40	SCD661-0880-3-3-140HA12-HP358	30902433
9,00	10	162	120	110	40	SCD661-0900-3-3-140HA12-HP358	30902435
9,50	10	162	120	110	40	SCD661-0950-3-3-140HA12-HP358	30902440
9,60	10	162	120	110	40	SCD661-0960-3-3-140HA12-HP358	30902441
9,80	10	162	120	110	40	SCD661-0980-3-3-140HA12-HP358	30902443
10,00	10	162	120	110	40	SCD661-1000-3-3-140HA12-HP358	30902445
10,20	12	204	156	142	45	SCD661-1020-3-3-140HA12-HP358	30902447
10,30	12	204	156	142	45	SCD661-1030-3-3-140HA12-HP358	30902448
10,50	12	204	156	142	45	SCD661-1050-3-3-140HA12-HP358	30902450

Tritan-Drill-Steel | Solid carbide twist drill SCD661 (12xD), internal coolant supply

Dimensions						Shank form HA	
d ₁ h7	d ₂ h6	l ₁	l ₂	l ₃	l ₄	Specification	Order no.
11,00	12	204	156	142	45	SCD661-1100-3-3-140HA12-HP358	30902455
11,50	12	204	156	142	45	SCD661-1150-3-3-140HA12-HP358	30902460
11,80	12	204	156	142	45	SCD661-1180-3-3-140HA12-HP358	30902463
12,00	12	204	156	142	45	SCD661-1200-3-3-140HA12-HP358	30902465
12,50	14	230	182	166	45	SCD661-1250-3-3-140HA12-HP358	30902467
13,00	14	230	182	166	45	SCD661-1300-3-3-140HA12-HP358	30902469
13,50	14	230	182	166	45	SCD661-1350-3-3-140HA12-HP358	30902471
14,00	14	230	182	166	45	SCD661-1400-3-3-140HA12-HP358	30902473
14,50	16	260	208	192	48	SCD661-1450-3-3-140HA12-HP358	30902475
15,00	16	260	208	192	48	SCD661-1500-3-3-140HA12-HP358	30902477
15,50	16	260	208	192	48	SCD661-1550-3-3-140HA12-HP358	30902479
16,00	16	260	208	192	48	SCD661-1600-3-3-140HA12-HP358	30902481
16,50	18	285	234	216	48	SCD661-1650-3-3-140HA12-HP358	30902483
17,00	18	285	234	216	48	SCD661-1700-3-3-140HA12-HP358	30902485
17,50	18	285	234	216	48	SCD661-1750-3-3-140HA12-HP358	30902487
18,00	18	285	234	216	48	SCD661-1800-3-3-140HA12-HP358	30902489
18,50	20	310	258	240	50	SCD661-1850-3-3-140HA12-HP358	30902491
19,00	20	310	258	240	50	SCD661-1900-3-3-140HA12-HP358	30902493
19,50	20	310	258	240	50	SCD661-1950-3-3-140HA12-HP358	30902495
20,00	20	310	258	240	50	SCD661-2000-3-3-140HA12-HP358	30902497

Configurable features



Diameter:
Diameter in increments of
0.01 mm freely selectable



Shank form:
Shank form: HB | HE

Specification:

SCD661-[diameter]-3-3-140[shank form]12-HP358

Dimensions of configurable series

d ₁ min.	d ₁ max.	d ₂ h6	l ₁	l ₂	l ₃	l ₄
4,00	4,70	6	102	64	58	36
4,71	6,00	6	116	78	70	36
6,01	8,00	8	146	108	94	36
8,01	10,00	10	162	120	110	40
10,01	12,00	12	204	156	142	45
12,01	14,00	14	230	182	166	45
14,01	16,00	16	260	208	192	48
16,01	18,00	18	285	234	216	48
18,01	20,00	20	310	258	240	50

Example:

SCD661-0431-3-3-140HE12-HP358

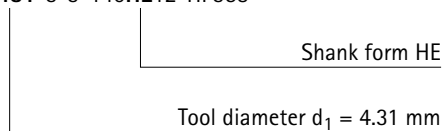

Dimensions in mm.

For cutting data recommendations, see end of chapter.

Special designs and other coatings available upon request.

MEGA-180°-Drill

Solid carbide twist drill
SCD231 (3xD), internal coolant supply

Design:
 Drill diameter: 3.00 - 20.00 mm
 Bore tolerance: \geq IT 9
 Cutting material: HP230
 Number of cutting edges: 2
 Number of guiding chamfers: 4
 Tip angle: 180°
 Helix angle: 30°

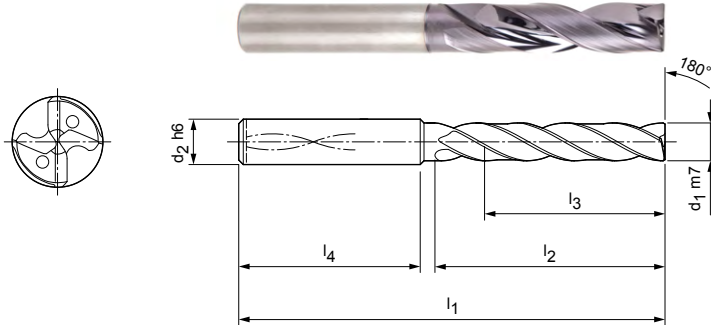

Stocked preferred series in shank form HA

Dimensions						Shank form HA	
d ₁ m7	d ₂ h6	l ₁	l ₂	l ₃	l ₄	Specification	Order no.
3,00	6	62	20	14	36	SCD231-0300-2-4-180HA03-HP230	30382647
3,10	6	62	20	14	36	SCD231-0310-2-4-180HA03-HP230	30382648
3,20	6	62	20	14	36	SCD231-0320-2-4-180HA03-HP230	30382649
3,30	6	62	20	14	36	SCD231-0330-2-4-180HA03-HP230	30382650
3,40	6	62	20	14	36	SCD231-0340-2-4-180HA03-HP230	30382651
3,50	6	62	20	14	36	SCD231-0350-2-4-180HA03-HP230	30382652
3,60	6	62	20	14	36	SCD231-0360-2-4-180HA03-HP230	30382653
3,70	6	62	20	14	36	SCD231-0370-2-4-180HA03-HP230	30382654
3,80	6	66	24	17	36	SCD231-0380-2-4-180HA03-HP230	30382655
3,90	6	66	24	17	36	SCD231-0390-2-4-180HA03-HP230	30382656
4,00	6	66	24	17	36	SCD231-0400-2-4-180HA03-HP230	30382657
4,10	6	66	24	17	36	SCD231-0410-2-4-180HA03-HP230	30382658
4,20	6	66	24	17	36	SCD231-0420-2-4-180HA03-HP230	30382659
4,30	6	66	24	17	36	SCD231-0430-2-4-180HA03-HP230	30382660
4,40	6	66	24	17	36	SCD231-0440-2-4-180HA03-HP230	30382661
4,50	6	66	24	17	36	SCD231-0450-2-4-180HA03-HP230	30382662
4,60	6	66	24	17	36	SCD231-0460-2-4-180HA03-HP230	30382663
4,65	6	66	24	17	36	SCD231-0465-2-4-180HA03-HP230	30382664
4,70	6	66	24	17	36	SCD231-0470-2-4-180HA03-HP230	30382665
4,80	6	66	28	20	36	SCD231-0480-2-4-180HA03-HP230	30382666
4,90	6	66	28	20	36	SCD231-0490-2-4-180HA03-HP230	30382667
5,00	6	66	28	20	36	SCD231-0500-2-4-180HA03-HP230	30382668
5,10	6	66	28	20	36	SCD231-0510-2-4-180HA03-HP230	30382669
5,20	6	66	28	20	36	SCD231-0520-2-4-180HA03-HP230	30382670
5,30	6	66	28	20	36	SCD231-0530-2-4-180HA03-HP230	30382671
5,40	6	66	28	20	36	SCD231-0540-2-4-180HA03-HP230	30382672
5,50	6	66	28	20	36	SCD231-0550-2-4-180HA03-HP230	30382673
5,55	6	66	28	20	36	SCD231-0555-2-4-180HA03-HP230	30382674
5,60	6	66	28	20	36	SCD231-0560-2-4-180HA03-HP230	30382675
5,70	6	66	28	20	36	SCD231-0570-2-4-180HA03-HP230	30382676
5,80	6	66	28	20	36	SCD231-0580-2-4-180HA03-HP230	30382677
5,90	6	66	28	20	36	SCD231-0590-2-4-180HA03-HP230	30382678
6,00	6	66	28	20	36	SCD231-0600-2-4-180HA03-HP230	30382679
6,10	8	79	34	24	36	SCD231-0610-2-4-180HA03-HP230	30382680
6,20	8	79	34	24	36	SCD231-0620-2-4-180HA03-HP230	30382681

MEGA-180°-Drill | Solid carbide twist drill SCD231 (3xD), internal coolant supply

Dimensions						Shank form HA	
d ₁ m7	d ₂ h6	l ₁	l ₂	l ₃	l ₄	Specification	Order no.
6,30	8	79	34	24	36	SCD231-0630-2-4-180HA03-HP230	30382682
6,40	8	79	34	24	36	SCD231-0640-2-4-180HA03-HP230	30382683
6,50	8	79	34	24	36	SCD231-0650-2-4-180HA03-HP230	30382684
6,60	8	79	34	24	36	SCD231-0660-2-4-180HA03-HP230	30382685
6,70	8	79	34	24	36	SCD231-0670-2-4-180HA03-HP230	30382686
6,80	8	79	34	24	36	SCD231-0680-2-4-180HA03-HP230	30382687
6,90	8	79	34	24	36	SCD231-0690-2-4-180HA03-HP230	30382688
7,00	8	79	34	24	36	SCD231-0700-2-4-180HA03-HP230	30382689
7,10	8	79	41	29	36	SCD231-0710-2-4-180HA03-HP230	30382690
7,20	8	79	41	29	36	SCD231-0720-2-4-180HA03-HP230	30382691
7,30	8	79	41	29	36	SCD231-0730-2-4-180HA03-HP230	30382692
7,40	8	79	41	29	36	SCD231-0740-2-4-180HA03-HP230	30382693
7,50	8	79	41	29	36	SCD231-0750-2-4-180HA03-HP230	30382694
7,60	8	79	41	29	36	SCD231-0760-2-4-180HA03-HP230	30382695
7,70	8	79	41	29	36	SCD231-0770-2-4-180HA03-HP230	30382696
7,80	8	79	41	29	36	SCD231-0780-2-4-180HA03-HP230	30382697
7,90	8	79	41	29	36	SCD231-0790-2-4-180HA03-HP230	30382698
8,00	8	79	41	29	36	SCD231-0800-2-4-180HA03-HP230	30382699
8,10	10	89	47	35	40	SCD231-0810-2-4-180HA03-HP230	30382700
8,20	10	89	47	35	40	SCD231-0820-2-4-180HA03-HP230	30382701
8,30	10	89	47	35	40	SCD231-0830-2-4-180HA03-HP230	30382702
8,40	10	89	47	35	40	SCD231-0840-2-4-180HA03-HP230	30382703
8,50	10	89	47	35	40	SCD231-0850-2-4-180HA03-HP230	30382704
8,60	10	89	47	35	40	SCD231-0860-2-4-180HA03-HP230	30382705
8,70	10	89	47	35	40	SCD231-0870-2-4-180HA03-HP230	30382706
8,80	10	89	47	35	40	SCD231-0880-2-4-180HA03-HP230	30382707
8,90	10	89	47	35	40	SCD231-0890-2-4-180HA03-HP230	30382708
9,00	10	89	47	35	40	SCD231-0900-2-4-180HA03-HP230	30382709
9,10	10	89	47	35	40	SCD231-0910-2-4-180HA03-HP230	30382710
9,20	10	89	47	35	40	SCD231-0920-2-4-180HA03-HP230	30382711
9,30	10	89	47	35	40	SCD231-0930-2-4-180HA03-HP230	30382712
9,40	10	89	47	35	40	SCD231-0940-2-4-180HA03-HP230	30382713
9,50	10	89	47	35	40	SCD231-0950-2-4-180HA03-HP230	30382714
9,60	10	89	47	35	40	SCD231-0960-2-4-180HA03-HP230	30382715
9,70	10	89	47	35	40	SCD231-0970-2-4-180HA03-HP230	30382716
9,80	10	89	47	35	40	SCD231-0980-2-4-180HA03-HP230	30382717
9,90	10	89	47	35	40	SCD231-0990-2-4-180HA03-HP230	30382718
10,00	10	89	47	35	40	SCD231-1000-2-4-180HA03-HP230	30382719
10,10	12	100	53	38	45	SCD231-1010-2-4-180HA03-HP230	30382720
10,20	12	100	53	38	45	SCD231-1020-2-4-180HA03-HP230	30382721
10,30	12	100	53	38	45	SCD231-1030-2-4-180HA03-HP230	30382722
10,40	12	100	53	38	45	SCD231-1040-2-4-180HA03-HP230	30382723
10,50	12	100	53	38	45	SCD231-1050-2-4-180HA03-HP230	30382724
10,60	12	100	53	38	45	SCD231-1060-2-4-180HA03-HP230	30382725
10,70	12	100	53	38	45	SCD231-1070-2-4-180HA03-HP230	30382726
10,80	12	100	53	38	45	SCD231-1080-2-4-180HA03-HP230	30382727
11,00	12	100	53	38	45	SCD231-1100-2-4-180HA03-HP230	30382729
11,10	12	100	53	38	45	SCD231-1110-2-4-180HA03-HP230	30382730
11,20	12	100	53	38	45	SCD231-1120-2-4-180HA03-HP230	30382731
11,30	12	100	53	38	45	SCD231-1130-2-4-180HA03-HP230	30382732
11,40	12	100	53	38	45	SCD231-1140-2-4-180HA03-HP230	30382733
11,50	12	100	53	38	45	SCD231-1150-2-4-180HA03-HP230	30382734
11,60	12	100	53	38	45	SCD231-1160-2-4-180HA03-HP230	30382735
11,70	12	100	53	38	45	SCD231-1170-2-4-180HA03-HP230	30382736
11,80	12	100	53	38	45	SCD231-1180-2-4-180HA03-HP230	30382737
11,90	12	100	53	38	45	SCD231-1190-2-4-180HA03-HP230	30382738
12,00	12	100	53	38	45	SCD231-1200-2-4-180HA03-HP230	30382739

Continued on next page.

MEGA-180°-Drill | Solid carbide twist drill SCD231 (3xD), internal coolant supply

Dimensions						Shank form HA	
d ₁ m7	d ₂ h6	l ₁	l ₂	l ₃	l ₄	Specification	Order no.
12,50	14	105	58	41	45	SCD231-1250-2-4-180HA03-HP230	30382740
12,70	14	105	58	41	45	SCD231-1270-2-4-180HA03-HP230	30852019
12,80	14	105	58	41	45	SCD231-1280-2-4-180HA03-HP230	30382741
13,00	14	105	58	41	45	SCD231-1300-2-4-180HA03-HP230	30382742
13,50	14	105	58	41	45	SCD231-1350-2-4-180HA03-HP230	30382743
13,80	14	105	58	41	45	SCD231-1380-2-4-180HA03-HP230	30382744
14,00	14	105	58	41	45	SCD231-1400-2-4-180HA03-HP230	30382745
14,50	16	113	63	43	48	SCD231-1450-2-4-180HA03-HP230	30382746
14,80	16	113	63	43	48	SCD231-1480-2-4-180HA03-HP230	30382747
15,00	16	113	63	43	48	SCD231-1500-2-4-180HA03-HP230	30382748
15,50	16	113	63	43	48	SCD231-1550-2-4-180HA03-HP230	30382749
15,80	16	113	63	43	48	SCD231-1580-2-4-180HA03-HP230	30382750
16,00	16	113	63	43	48	SCD231-1600-2-4-180HA03-HP230	30382751
16,50	18	121	71	49	48	SCD231-1650-2-4-180HA03-HP230	30382752
16,80	18	121	71	49	48	SCD231-1680-2-4-180HA03-HP230	30382753
17,00	18	121	71	49	48	SCD231-1700-2-4-180HA03-HP230	30382754
17,50	18	121	71	49	48	SCD231-1750-2-4-180HA03-HP230	30382755
18,00	18	121	71	49	48	SCD231-1800-2-4-180HA03-HP230	30382757
18,50	20	129	77	53	50	SCD231-1850-2-4-180HA03-HP230	30382758
18,80	20	129	77	53	50	SCD231-1880-2-4-180HA03-HP230	30382759
19,00	20	129	77	53	50	SCD231-1900-2-4-180HA03-HP230	30382760
19,50	20	129	77	53	50	SCD231-1950-2-4-180HA03-HP230	30382761
20,00	20	129	77	53	50	SCD231-2000-2-4-180HA03-HP230	30382763

Configurable features



Diameter:
Diameter in increments of
0.01 mm freely selectable



Shank form:
Shank form: HB | HE

Specification:

SCD231-[diameter]-3-4-180[shank form]03-HP230

Dimensions of configurable series

d ₁ min.	d ₁ max.	d ₂ h6	l ₁	l ₂	l ₃	l ₄
3,00	3,70	6	62	20	14	36
3,71	4,70	6	66	24	17	36
4,71	6,00	6	66	28	20	36
6,01	6,80	8	79	34	24	36
6,81	8,00	8	79	41	29	36
8,01	10,00	10	89	47	35	40
10,01	12,00	12	100	53	38	45
12,01	14,00	14	105	58	41	45
14,01	16,00	16	113	63	43	48
16,01	18,00	18	121	71	49	48
18,01	20,00	20	129	77	53	50

Example:

SCD231-0431-2-3-140HE03-HP230

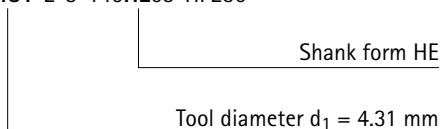

Dimensions in mm.

For cutting data recommendations, see end of chapter.

Special designs and other coatings available upon request.

MEGA-180°-Drill

Solid carbide twist drill
SCD231 (5xD), internal coolant supply

Design:
 Drill diameter: 3.00 - 20.00 mm
 Bore tolerance: \geq IT 9
 Cutting material: HP230
 Number of cutting edges: 2
 Number of guiding chamfers: 4
 Tip angle: 180°
 Helix angle: 30°

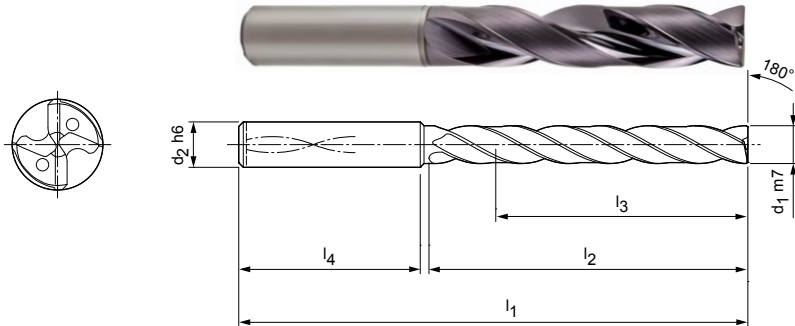

Stocked preferred series in shank form HA

Dimensions						Shank form HA	
d ₁ m7	d ₂ h6	l ₁	l ₂	l ₃	l ₄	Specification	Order no.
3,00	6	66	28	23	36	SCD231-0300-2-4-180HA05-HP230	30382764
3,10	6	66	28	23	36	SCD231-0310-2-4-180HA05-HP230	30382765
3,20	6	66	28	23	36	SCD231-0320-2-4-180HA05-HP230	30382766
3,30	6	66	28	23	36	SCD231-0330-2-4-180HA05-HP230	30382767
3,40	6	66	28	23	36	SCD231-0340-2-4-180HA05-HP230	30382768
3,50	6	66	28	23	36	SCD231-0350-2-4-180HA05-HP230	30382769
3,60	6	66	28	23	36	SCD231-0360-2-4-180HA05-HP230	30382770
3,70	6	66	28	23	36	SCD231-0370-2-4-180HA05-HP230	30382771
3,80	6	74	36	29	36	SCD231-0380-2-4-180HA05-HP230	30382772
3,90	6	74	36	29	36	SCD231-0390-2-4-180HA05-HP230	30382773
4,00	6	74	36	29	36	SCD231-0400-2-4-180HA05-HP230	30382774
4,10	6	74	36	29	36	SCD231-0410-2-4-180HA05-HP230	30382775
4,20	6	74	36	29	36	SCD231-0420-2-4-180HA05-HP230	30382776
4,30	6	74	36	29	36	SCD231-0430-2-4-180HA05-HP230	30382777
4,40	6	74	36	29	36	SCD231-0440-2-4-180HA05-HP230	30382778
4,50	6	74	36	29	36	SCD231-0450-2-4-180HA05-HP230	30382779
4,60	6	74	36	29	36	SCD231-0460-2-4-180HA05-HP230	30382780
4,80	6	82	44	35	36	SCD231-0480-2-4-180HA05-HP230	30382783
4,90	6	82	44	35	36	SCD231-0490-2-4-180HA05-HP230	30382784
5,00	6	82	44	35	36	SCD231-0500-2-4-180HA05-HP230	30382785
5,10	6	82	44	35	36	SCD231-0510-2-4-180HA05-HP230	30382786
5,20	6	82	44	35	36	SCD231-0520-2-4-180HA05-HP230	30382787
5,30	6	82	44	35	36	SCD231-0530-2-4-180HA05-HP230	30382788
5,40	6	82	44	35	36	SCD231-0540-2-4-180HA05-HP230	30382789
5,50	6	82	44	35	36	SCD231-0550-2-4-180HA05-HP230	30382790
5,55	6	82	44	35	36	SCD231-0555-2-4-180HA05-HP230	30382791
5,60	6	82	44	35	36	SCD231-0560-2-4-180HA05-HP230	30382792
5,70	6	82	44	35	36	SCD231-0570-2-4-180HA05-HP230	30382793
5,80	6	82	44	35	36	SCD231-0580-2-4-180HA05-HP230	30382794
5,90	6	82	44	35	36	SCD231-0590-2-4-180HA05-HP230	30382795
6,00	6	82	44	35	36	SCD231-0600-2-4-180HA05-HP230	30382796
6,10	8	91	53	43	36	SCD231-0610-2-4-180HA05-HP230	30382797
6,20	8	91	53	43	36	SCD231-0620-2-4-180HA05-HP230	30382798
6,30	8	91	53	43	36	SCD231-0630-2-4-180HA05-HP230	30382799
6,40	8	91	53	43	36	SCD231-0640-2-4-180HA05-HP230	30382800

MEGA-180°-Drill | Solid carbide twist drill SCD231 (5xD), internal coolant supply

Dimensions						Shank form HA	
d ₁ m7	d ₂ h6	l ₁	l ₂	l ₃	l ₄	Specification	Order no.
6,50	8	91	53	43	36	SCD231-0650-2-4-180HA05-HP230	30382801
6,60	8	91	53	43	36	SCD231-0660-2-4-180HA05-HP230	30382802
6,70	8	91	53	43	36	SCD231-0670-2-4-180HA05-HP230	30382803
6,80	8	91	53	43	36	SCD231-0680-2-4-180HA05-HP230	30382804
6,90	8	91	53	43	36	SCD231-0690-2-4-180HA05-HP230	30382805
7,00	8	91	53	43	36	SCD231-0700-2-4-180HA05-HP230	30382806
7,10	8	91	53	43	36	SCD231-0710-2-4-180HA05-HP230	30382807
7,20	8	91	53	43	36	SCD231-0720-2-4-180HA05-HP230	30382808
7,30	8	91	53	43	36	SCD231-0730-2-4-180HA05-HP230	30382809
7,40	8	91	53	43	36	SCD231-0740-2-4-180HA05-HP230	30382810
7,50	8	91	53	43	36	SCD231-0750-2-4-180HA05-HP230	30382811
7,60	8	91	53	43	36	SCD231-0760-2-4-180HA05-HP230	30382812
7,80	8	91	53	43	36	SCD231-0780-2-4-180HA05-HP230	30382814
7,90	8	91	53	43	36	SCD231-0790-2-4-180HA05-HP230	30382815
8,00	8	91	53	43	36	SCD231-0800-2-4-180HA05-HP230	30382816
8,10	10	103	61	49	40	SCD231-0810-2-4-180HA05-HP230	30382817
8,20	10	103	61	49	40	SCD231-0820-2-4-180HA05-HP230	30382818
8,30	10	103	61	49	40	SCD231-0830-2-4-180HA05-HP230	30382819
8,40	10	103	61	49	40	SCD231-0840-2-4-180HA05-HP230	30382820
8,50	10	103	61	49	40	SCD231-0850-2-4-180HA05-HP230	30382821
8,60	10	103	61	49	40	SCD231-0860-2-4-180HA05-HP230	30382822
8,70	10	103	61	49	40	SCD231-0870-2-4-180HA05-HP230	30382823
8,80	10	103	61	49	40	SCD231-0880-2-4-180HA05-HP230	30382824
8,90	10	103	61	49	40	SCD231-0890-2-4-180HA05-HP230	30382825
9,00	10	103	61	49	40	SCD231-0900-2-4-180HA05-HP230	30382826
9,10	10	103	61	49	40	SCD231-0910-2-4-180HA05-HP230	30382827
9,20	10	103	61	49	40	SCD231-0920-2-4-180HA05-HP230	30382828
9,30	10	103	61	49	40	SCD231-0930-2-4-180HA05-HP230	30382829
9,40	10	103	61	49	40	SCD231-0940-2-4-180HA05-HP230	30382830
9,50	10	103	61	49	40	SCD231-0950-2-4-180HA05-HP230	30382831
9,60	10	103	61	49	40	SCD231-0960-2-4-180HA05-HP230	30382832
9,70	10	103	61	49	40	SCD231-0970-2-4-180HA05-HP230	30382833
9,80	10	103	61	49	40	SCD231-0980-2-4-180HA05-HP230	30382834
9,90	10	103	61	49	40	SCD231-0990-2-4-180HA05-HP230	30382835
10,00	10	103	61	49	40	SCD231-1000-2-4-180HA05-HP230	30382836
10,10	12	116	69	54	45	SCD231-1010-2-4-180HA05-HP230	30382838
10,20	12	116	69	54	45	SCD231-1020-2-4-180HA05-HP230	30382840
10,30	12	116	69	54	45	SCD231-1030-2-4-180HA05-HP230	30382841
10,40	12	116	69	54	45	SCD231-1040-2-4-180HA05-HP230	30382842
10,50	12	116	69	54	45	SCD231-1050-2-4-180HA05-HP230	30382843
10,60	12	116	69	54	45	SCD231-1060-2-4-180HA05-HP230	30382844
10,65	12	116	69	54	45	SCD231-1065-2-4-180HA05-HP230	31198519
10,80	12	116	69	54	45	SCD231-1080-2-4-180HA05-HP230	30382846
11,00	12	116	69	54	45	SCD231-1100-2-4-180HA05-HP230	30382848
11,20	12	116	69	54	45	SCD231-1120-2-4-180HA05-HP230	30382850
11,50	12	116	69	54	45	SCD231-1150-2-4-180HA05-HP230	30382853
11,60	12	116	69	54	45	SCD231-1160-2-4-180HA05-HP230	30382854
11,70	12	116	69	54	45	SCD231-1170-2-4-180HA05-HP230	30382855
11,80	12	116	69	54	45	SCD231-1180-2-4-180HA05-HP230	30382856
12,00	12	116	69	54	45	SCD231-1200-2-4-180HA05-HP230	30382858
12,50	14	122	75	58	45	SCD231-1250-2-4-180HA05-HP230	30382859
12,80	14	122	75	58	45	SCD231-1280-2-4-180HA05-HP230	30382860
13,00	14	122	75	58	45	SCD231-1300-2-4-180HA05-HP230	30382861
13,50	14	122	75	58	45	SCD231-1350-2-4-180HA05-HP230	30382862
13,80	14	122	75	58	45	SCD231-1380-2-4-180HA05-HP230	30382863
14,00	14	122	75	58	45	SCD231-1400-2-4-180HA05-HP230	30382864
14,50	16	131	81	61	48	SCD231-1450-2-4-180HA05-HP230	30382865

MEGA-180°-Drill | Solid carbide twist drill SCD231 (5xD), internal coolant supply

Dimensions						Shank form HA	
d ₁ m7	d ₂ h6	l ₁	l ₂	l ₃	l ₄	Specification	Order no.
14,80	16	131	81	61	48	SCD231-1480-2-4-180HA05-HP230	30382866
15,00	16	131	81	61	48	SCD231-1500-2-4-180HA05-HP230	30382867
15,50	16	131	81	61	48	SCD231-1550-2-4-180HA05-HP230	30382868
15,80	16	131	81	61	48	SCD231-1580-2-4-180HA05-HP230	30382869
16,00	16	131	81	61	48	SCD231-1600-2-4-180HA05-HP230	30382870
16,50	18	141	91	69	48	SCD231-1650-2-4-180HA05-HP230	30382871
17,00	18	141	91	69	48	SCD231-1700-2-4-180HA05-HP230	30382873
17,50	18	141	91	69	48	SCD231-1750-2-4-180HA05-HP230	30382874
17,80	18	141	91	69	48	SCD231-1780-2-4-180HA05-HP230	30382875
18,00	18	141	91	69	48	SCD231-1800-2-4-180HA05-HP230	30382876
18,50	20	151	99	75	50	SCD231-1850-2-4-180HA05-HP230	30382877
19,00	20	151	99	75	50	SCD231-1900-2-4-180HA05-HP230	30382879
19,80	20	151	99	75	50	SCD231-1980-2-4-180HA05-HP230	30382881
20,00	20	151	99	75	50	SCD231-2000-2-4-180HA05-HP230	30382882

Configurable features



Diameter:
Diameter in increments of
0.01 mm freely selectable



Shank form:
Shank form: HB | HE

Specification:

SCD231-[diameter]-2-4-180[shank form]05-HP230

Dimensions of configurable series

d ₁ min.	d ₁ max.	d ₂ h6	l ₁	l ₂	l ₃	l ₄
3,00	3,70	6	66	28	23	36
3,71	4,70	6	74	36	29	36
4,71	6,00	6	82	44	35	36
6,01	8,00	8	91	53	43	36
8,01	10,00	10	103	61	49	40
10,01	12,00	12	116	69	54	45
12,01	14,00	14	122	75	58	45
14,01	16,00	16	131	81	61	48
16,01	18,00	18	141	91	69	48
18,01	20,00	20	151	99	75	50

Example:

SCD231-0431-2-4-180HE05-HP230

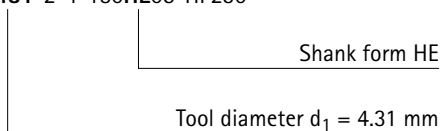

Dimensions in mm.

For cutting data recommendations, see end of chapter.

Special designs and other coatings available upon request.

MICRO-Step-Drill-Steel

Solid carbide step drill
SCD581, internal coolant supply

Design:
 Drill diameter: 1,00 – 3,00 mm
 Bore tolerance: IT 9 (achievable)
 Cutting material: HP246
 Number of cutting edges: 2
 Number of guiding chamfers: 2
 Tip angle: 142°

Application:
 Pilot drill specially adapted to MICRO-Deep-Drill.
 Can be used to a maximum of < 3.00 mm diameter with countersink step for optimum insertion of the following deep drill.

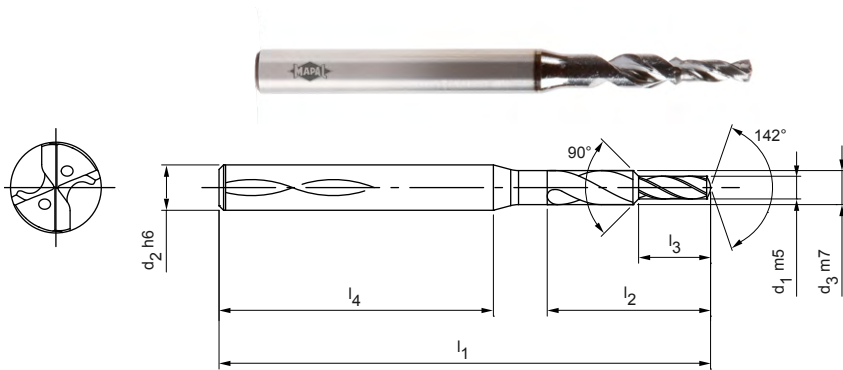

Dimensions							Shank form HA	
d ₁ m5	d ₂ h6	d ₃ m7	l ₁	l ₂	l ₃	l ₄	Specification	Order No.
1,00	3,00	1,50	50	7,2	3,0	38	SCD581-0100-2-2-142HA-HP246	31080870
1,10	3,00	1,65	50	7,9	3,3	37,5	SCD581-0110-2-2-142HA-HP246	31080871
1,20	3,00	1,80	50	8,6	3,6	36,9	SCD581-0120-2-2-142HA-HP246	31080872
1,30	3,00	1,95	50	9,4	3,9	36,3	SCD581-0130-2-2-142HA-HP246	31080873
1,40	3,00	2,10	50	10,1	4,2	35,7	SCD581-0140-2-2-142HA-HP246	31080874
1,50	3,00	2,25	50	10,8	4,5	35,1	SCD581-0150-2-2-142HA-HP246	31080875
1,60	3,00	2,40	50	11,5	4,8	34,6	SCD581-0160-2-2-142HA-HP246	31080876
1,70	3,00	2,55	50	12,2	5,1	34	SCD581-0170-2-2-142HA-HP246	31080877
1,80	3,00	2,70	50	13,0	5,4	33,4	SCD581-0180-2-2-142HA-HP246	31080878
1,90	4,00	2,85	55	13,7	5,7	35,9	SCD581-0190-2-2-142HA-HP246	31080879
2,00	4,00	3,00	55	14,4	6,0	35,3	SCD581-0200-2-2-142HA-HP246	31080880
2,10	4,00	3,15	55	15,1	6,3	34,8	SCD581-0210-2-2-142HA-HP246	31080881
2,20	4,00	3,30	55	15,8	6,6	34,2	SCD581-0220-2-2-142HA-HP246	31080882
2,30	4,00	3,45	55	16,6	6,9	33,6	SCD581-0230-2-2-142HA-HP246	31080883
2,40	4,00	3,60	55	17,3	7,2	33	SCD581-0240-2-2-142HA-HP246	31080884
2,50	4,00	3,75	55	18,0	7,5	32,4	SCD581-0250-2-2-142HA-HP246	31080885
2,60	6,00	3,90	66	18,7	7,8	39,1	SCD581-0260-2-2-142HA-HP246	31080886
2,70	6,00	4,05	66	19,4	8,1	38,5	SCD581-0270-2-2-142HA-HP246	31080887
2,80	6,00	4,20	66	20,2	8,4	37,9	SCD581-0280-2-2-142HA-HP246	31080888
2,90	6,00	4,35	66	20,9	8,7	37,4	SCD581-0290-2-2-142HA-HP246	31080889
3,00	6,00	4,50	66	21,6	9,0	36,8	SCD581-0300-2-2-142HA-HP246	31080890

Dimensions in mm.
 For cutting data recommendations, see end of chapter.
 Special designs and other coatings available upon request.

MEGA-Deep-Drill-Steel

Solid carbide twist drill
SCD701 (15xD), internal coolant supply

Design:
 Drill diameter: 3.00 - 16.00 mm
 Bore tolerance: IT9 (available)
 Shank form: HA
 Cutting material: HP400
 Number of cutting edges: 2
 Tip angle: 137°
 Helix angle: 30°
 Special features: Head coating

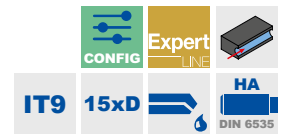
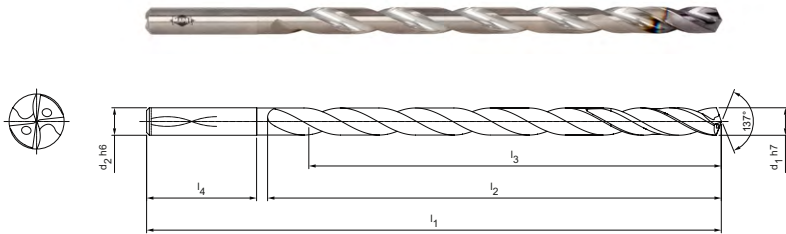

Preferred series available from stock

Dimensions						Shank form HA	
d ₁ h7	d ₂ h6	l ₁	l ₂	l ₃	l ₄	Specification	Order no.
3,00	4,00	90	58	52	28	SCD701-0300-2-4-137HA15-HP400	31459705
3,50	4,00	98	66	60	28	SCD701-0350-2-4-137HA15-HP400	31459706
4,00	4,00	98	66	60	28	SCD701-0400-2-4-137HA15-HP400	31459707
4,50	5,00	107	75	68	28	SCD701-0450-2-4-137HA15-HP400	31459708
5,00	5,00	115	83	75	28	SCD701-0500-2-4-137HA15-HP400	31459709
5,50	6,00	131	91	83	36	SCD701-0550-2-4-137HA15-HP400	31459720
6,00	6,00	139	99	90	36	SCD701-0600-2-4-137HA15-HP400	31459721
7,00	8,00	156	116	105	36	SCD701-0700-2-4-137HA15-HP400	31459722
8,00	8,00	172	132	120	36	SCD701-0800-2-4-137HA15-HP400	31459723
9,00	10,00	193	149	135	40	SCD701-0900-2-4-137HA15-HP400	31459724
9,50	10,00	209	165	150	40	SCD701-0950-2-4-137HA15-HP400	31459725
10,00	10,00	209	165	150	40	SCD701-1000-2-4-137HA15-HP400	31459726
11,00	12,00	231	182	165	45	SCD701-1100-2-4-137HA15-HP400	31459727
12,00	12,00	247	198	180	45	SCD701-1200-2-4-137HA15-HP400	31459728
13,00	14,00	264	215	195	45	SCD701-1300-2-4-137HA15-HP400	31459729
14,00	14,00	280	231	210	45	SCD701-1400-2-4-137HA15-HP400	31459730
15,00	16,00	300	248	225	48	SCD701-1500-2-4-137HA15-HP400	31459731
16,00	16,00	316	264	240	48	SCD701-1600-2-4-137HA15-HP400	31459732

Configurable features



Diameter:
Diameter in increments of 0.01 mm freely selectable



Specification:
SCD701-[diameter]-2-4-137HA15-HP400

Example:

SCD701-0735-2-4-137HA15-HP400

Tool diameter d₁ = 7.35 mm

Dimensions in mm.

For cutting data recommendations and coolant specifications, as well as information on the deep hole drilling process, see chapter "Technical Appendix".
 Special designs and other coatings available upon request.

Dimensions of configurable series h7

d ₁ min.	d ₁ max.	d ₂ h6	l ₁	l ₂	l ₃	l ₄
3,00	3,49	4,00	90	58	52	28
3,50	4,00	4,00	98	66	60	28
4,01	4,50	5,00	107	75	68	28
4,51	5,00	5,00	115	83	75	28
5,01	5,50	6,00	131	91	83	36
5,51	6,00	6,00	139	99	90	36
6,01	7,00	8,00	156	116	105	36
7,01	8,00	8,00	172	132	120	36
8,01	9,00	10,00	193	149	135	40
9,01	10,00	10,00	209	165	150	40
10,01	11,00	12,00	231	182	165	45
11,01	12,00	12,00	247	198	180	45
12,01	13,00	14,00	264	215	195	45
13,01	14,00	14,00	280	231	210	45
14,01	15,00	16,00	300	248	225	48
15,01	16,00	16,00	316	264	240	48

MICRO-Deep-Drill

Solid carbide twist drill
SCD171 (20xD), internal coolant supply

Design:
 Drill diameter: 1,00 – 2,99 mm
 Bore tolerance: ≥ IT 9
 Cutting material: HP246
 Number of cutting edges: 2
 Number of guiding chamfers: 4
 Tip angle: 135°
 Side rake angle: 30°

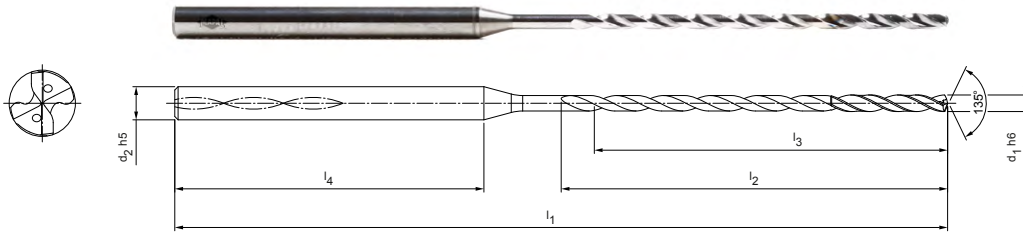

Dimensions							Shank form HA	
d ₁ h6	d ₂ h5	l ₁	l ₂	l ₃	L/d relation	l ₄	Specification	Order No.
1,00	3	62	27	25	25	28	SCD171-0100-2-4-135HA20-HP246	30998795
1,10	3	62	27	25	23	28	SCD171-0110-2-4-135HA20-HP246	30998796
1,20	3	62	27	25	21	28	SCD171-0120-2-4-135HA20-HP246	30998798
1,30	3	70	35	33	25	28	SCD171-0130-2-4-135HA20-HP246	30998799
1,40	3	70	35	32	23	28	SCD171-0140-2-4-135HA20-HP246	30998800
1,50	3	70	35	32	21	28	SCD171-0150-2-4-135HA20-HP246	30998801
1,60	3	75	41	38	24	28	SCD171-0160-2-4-135HA20-HP246	30998802
1,70	3	75	41	38	22	28	SCD171-0170-2-4-135HA20-HP246	30998803
1,80	3	75	41	38	21	28	SCD171-0180-2-4-135HA20-HP246	30998804
1,90	3	80	46	43	23	28	SCD171-0190-2-4-135HA20-HP246	30998805
2,00	3	80	46	43	22	28	SCD171-0200-2-4-135HA20-HP246	30998806
2,10	3	80	46	42	20	28	SCD171-0210-2-4-135HA20-HP246	30998807
2,20	3	90	55	51	23	28	SCD171-0220-2-4-135HA20-HP246	30998808
2,30	3	90	55	51	22	28	SCD171-0230-2-4-135HA20-HP246	30998809
2,40	3	90	55	51	21	28	SCD171-0240-2-4-135HA20-HP246	30998810
2,50	3	90	55	51	20	28	SCD171-0250-2-4-135HA20-HP246	30998811
2,60	3	100	66	62	24	28	SCD171-0260-2-4-135HA20-HP246	30998812
2,70	3	100	66	61	23	28	SCD171-0270-2-4-135HA20-HP246	30998813
2,80	3	100	66	61	22	28	SCD171-0280-2-4-135HA20-HP246	30998814
2,90	3	100	66	61	21	28	SCD171-0290-2-4-135HA20-HP246	30998815

MICRO-Deep-Drill | Solid carbide twist drill SCD171 (20xD), internal coolant supply

Configurable features



Diameter:
Diameter in increments of
0.01 mm freely selectable

**Specification:**

SCD171-[diameter]-2-4-135HA20-HP246

Example:

SCD171-0221-2-4-135HA20-HP246

Tool diameter $d_1 = 2.21$ mm

Dimensions of configurable series

d_1 h6	d_2 h5	l_1	l_2	l_3	l_4
1,00 - 1,20	3	62	27	25	28
1,21 - 1,50	3	70	35	32	28
1,51 - 1,80	3	75	41	38	28
1,81 - 2,10	3	80	46	42	28
2,11 - 2,50	3	90	55	51	28
2,51 - 2,99	3	100	66	61	28

Dimensions in mm.

For recommended cutting values, see page 12/13.

Special designs and other coatings on request.

MEGA-Deep-Drill-Steel

Solid carbide twist drill
SCD701 (20xD), internal coolant supply

Design:
 Drill diameter: 3.00 - 16.00 mm
 Bore tolerance: IT9 (available)
 Shank form: HA
 Cutting material: HP400
 Number of cutting edges: 2
 Tip angle: 137°
 Helix angle: 30°
 Special features: Head coating

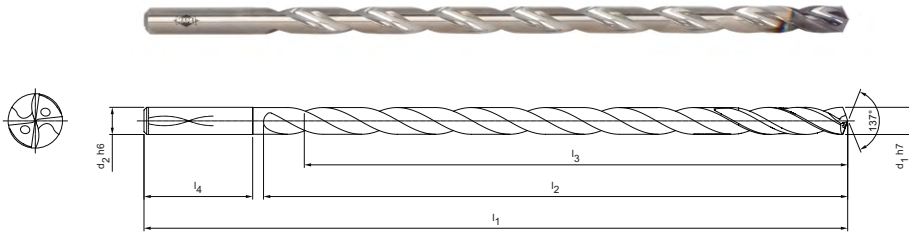

P
1
2
3
4
5
6
M
1
2
3
K
1
2
3
N
1
2
3
4
S
1
2
3
4
5
H
1
2
3

Preferred series available from stock

Dimensions						Shank form HA	
d ₁ h7	d ₂ h6	l ₁	l ₂	l ₃	l ₄	Specification	Order no.
3,00	4,00	108	76	70	28	SCD701-0300-2-4-137HA20-HP400	31459733
3,50	4,00	118	86	80	28	SCD701-0350-2-4-137HA20-HP400	31459734
4,00	4,00	118	86	80	28	SCD701-0400-2-4-137HA20-HP400	31459735
4,50	5,00	129	97	90	28	SCD701-0450-2-4-137HA20-HP400	31459736
5,00	5,00	140	108	100	28	SCD701-0500-2-4-137HA20-HP400	31459737
5,50	6,00	159	119	110	36	SCD701-0550-2-4-137HA20-HP400	31459738
6,00	6,00	169	129	120	36	SCD701-0600-2-4-137HA20-HP400	31459739
6,50	8,00	191	151	140	36	SCD701-0650-2-4-137HA20-HP400	31459740
7,00	8,00	191	151	140	36	SCD701-0700-2-4-137HA20-HP400	31459741
8,00	8,00	212	172	160	36	SCD701-0800-2-4-137HA20-HP400	31459742
9,00	10,00	238	194	180	40	SCD701-0900-2-4-137HA20-HP400	31459743
10,00	10,00	259	215	200	40	SCD701-1000-2-4-137HA20-HP400	31459744
11,00	12,00	286	237	220	45	SCD701-1100-2-4-137HA20-HP400	31459745
12,00	12,00	307	258	240	45	SCD701-1200-2-4-137HA20-HP400	31459746
13,00	14,00	329	280	260	45	SCD701-1300-2-4-137HA20-HP400	31459747
14,00	14,00	350	301	280	45	SCD701-1400-2-4-137HA20-HP400	31459748
15,00	16,00	375	323	300	48	SCD701-1500-2-4-137HA20-HP400	31459749
16,00	16,00	396	344	320	48	SCD701-1600-2-4-137HA20-HP400	31459750

Configurable features

Diameter:
Diameter in increments of 0.01 mm freely selectable

Specification:
SCD701-[diameter]-2-4-137HA20-HP400

Example:
SCD701-0735-2-4-137HA20-HP400

Tool diameter d₁ = 7.35 mm

Dimensions in mm.
 For cutting data recommendations and coolant specifications, as well as information on the deep hole drilling process, see chapter "Technical Appendix".
 Special designs and other coatings available upon request.

Dimensions of configurable series h7

d ₁ min.	d ₁ max.	d ₂ h6	l ₁	l ₂	l ₃	l ₄
3,00	3,49	4,00	108	76	70	28
3,50	4,00	4,00	118	86	80	28
4,01	4,50	5,00	129	97	90	28
4,51	5,00	5,00	140	108	100	28
5,01	5,50	6,00	159	119	110	36
5,51	6,00	6,00	169	129	120	36
6,01	7,00	8,00	191	151	140	36
7,01	8,00	8,00	212	172	160	36
8,01	9,00	10,00	238	194	180	40
9,01	10,00	10,00	259	215	200	40
10,01	11,00	12,00	286	237	220	45
11,01	12,00	12,00	307	258	240	45
12,01	13,00	14,00	329	280	260	45
13,01	14,00	14,00	350	301	280	45
14,01	15,00	16,00	375	323	300	48
15,01	16,00	16,00	396	344	320	48

MEGA-Deep-Drill-Steel

Solid carbide twist drill
SCD701 (25xD), internal coolant supply

Design:
 Drill diameter: 3.00 - 14.00 mm
 Bore tolerance: IT9 (available)
 Shank form: HA
 Cutting material: HP400
 Number of cutting edges: 2
 Tip angle: 137°
 Helix angle: 30°
 Special features: Head coating

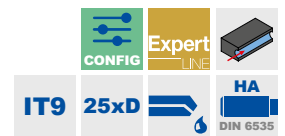
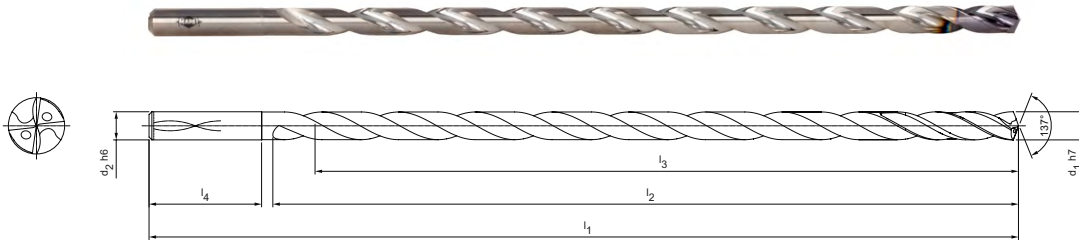

Preferred series available from stock

Dimensions						Shank form HA	
d ₁ h7	d ₂ h6	l ₁	l ₂	l ₃	l ₄	Specification	Order no.
3,00	4,00	125	93	87	28	SCD701-0300-2-4-137HA25-HP400	31459751
3,50	4,00	138	106	100	28	SCD701-0350-2-4-137HA25-HP400	31459752
4,00	4,00	138	106	100	28	SCD701-0400-2-4-137HA25-HP400	31459753
4,50	5,00	152	120	113	28	SCD701-0450-2-4-137HA25-HP400	31459754
5,00	5,00	165	133	125	28	SCD701-0500-2-4-137HA25-HP400	31459755
5,50	6,00	186	146	137	36	SCD701-0550-2-4-137HA25-HP400	31459756
6,00	6,00	199	159	150	36	SCD701-0600-2-4-137HA25-HP400	31459757
7,00	8,00	226	186	175	36	SCD701-0700-2-4-137HA25-HP400	31459758
8,00	8,00	252	212	200	36	SCD701-0800-2-4-137HA25-HP400	31459759
9,00	10,00	283	239	225	40	SCD701-0900-2-4-137HA25-HP400	31459760
10,00	10,00	309	265	250	40	SCD701-1000-2-4-137HA25-HP400	31459761
11,00	12,00	341	292	275	45	SCD701-1100-2-4-137HA25-HP400	31459762
12,00	12,00	367	318	300	45	SCD701-1200-2-4-137HA25-HP400	31459763
13,00	14,00	394	345	325	45	SCD701-1300-2-4-137HA25-HP400	31459764
14,00	14,00	420	371	350	45	SCD701-1400-2-4-137HA25-HP400	31459765

Configurable features



Diameter:
Diameter in increments of 0.01 mm freely selectable



Specification:
SCD701-[diameter]-2-4-137HA25-HP400

Example:
SCD701-0735-2-4-137HA25-HP400
 Tool diameter d₁ = 7.35 mm

Dimensions in mm.
 For cutting data recommendations and coolant specifications, as well as information on the deep hole drilling process, see chapter "Technical Appendix".
 Special designs and other coatings available upon request.

Dimensions of configurable series h7

d ₁ min.	d ₁ max.	d ₂ h6	l ₁	l ₂	l ₃	l ₄
3,00	3,49	4,00	125	93	87	28
3,50	4,00	4,00	138	106	100	28
4,01	4,50	5,00	152	120	113	28
4,51	5,00	5,00	165	133	125	28
5,01	5,50	6,00	186	146	138	36
5,51	6,00	6,00	199	159	150	36
6,01	7,00	8,00	226	186	175	36
7,01	8,00	8,00	252	212	200	36
8,01	9,00	10,00	283	239	225	40
9,01	10,00	10,00	309	265	250	40
10,01	11,00	12,00	341	292	275	45
11,01	12,00	12,00	367	318	300	45
12,01	13,00	14,00	394	345	325	45
13,01	14,00	14,00	420	371	350	45

MICRO-Deep-Drill

Solid carbide twist drill
SCD171 (30xD), internal coolant supply

Design:
 Drill diameter: 1,00 – 2,99 mm
 Bore tolerance: ≥ IT 9
 Cutting material: HP246
 Number of cutting edges: 2
 Number of guiding chamfers: 4
 Tip angle: 135°
 Side rake angle: 30°

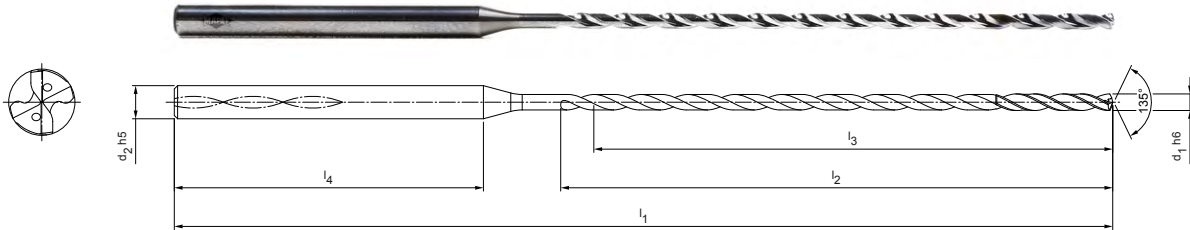

P
1
2
3
4
5
6
M
1
2
3
K
1
2
3
N
1
2
3
4
S
1
2
3
4
5
H
1
2
3









Dimensions							Shank form HA	
d ₁ h6	d ₂ h5	l ₁	l ₂	l ₃	L/d relation	l ₄	Specification	Order No.
1,00	3	75	38	36	36	28	SCD171-0100-2-4-135HA30-HP246	30998816
1,10	3	75	38	36	33	28	SCD171-0110-2-4-135HA30-HP246	30998817
1,20	3	75	38	36	30	28	SCD171-0120-2-4-135HA30-HP246	30998818
1,30	3	85	50	48	37	28	SCD171-0130-2-4-135HA30-HP246	30998819
1,40	3	85	50	47	34	28	SCD171-0140-2-4-135HA30-HP246	30998820
1,50	3	85	50	47	31	28	SCD171-0150-2-4-135HA30-HP246	30998821
1,60	3	95	59	56	35	28	SCD171-0160-2-4-135HA30-HP246	30998822
1,70	3	95	59	56	33	28	SCD171-0170-2-4-135HA30-HP246	30998823
1,80	3	95	59	56	31	28	SCD171-0180-2-4-135HA30-HP246	30998824
1,90	3	100	66	63	33	28	SCD171-0190-2-4-135HA30-HP246	30998825
2,00	3	100	66	63	32	28	SCD171-0200-2-4-135HA30-HP246	30998826
2,10	3	100	66	62	30	28	SCD171-0210-2-4-135HA30-HP246	30998827
2,20	3	115	80	76	35	28	SCD171-0220-2-4-135HA30-HP246	30998828
2,30	3	115	80	76	33	28	SCD171-0230-2-4-135HA30-HP246	30998829
2,40	3	115	80	76	32	28	SCD171-0240-2-4-135HA30-HP246	30998830
2,50	3	115	80	76	30	28	SCD171-0250-2-4-135HA30-HP245	30451572
2,60	3	130	96	92	35	28	SCD171-0260-2-4-135HA30-HP246	30998832
2,70	3	130	96	91	34	28	SCD171-0270-2-4-135HA30-HP246	30998833
2,80	3	130	96	91	33	28	SCD171-0280-2-4-135HA30-HP246	30998834
2,90	3	130	96	91	31	28	SCD171-0290-2-4-135HA30-HP246	30998835

MICRO-Deep-Drill | Solid carbide twist drill SCD171 (30xD), internal coolant supply

Configurable features



Diameter:
Diameter in increments of
0.01 mm freely selectable

**Specification:**

SCD171-[diameter]-2-4-135HA30-HP246

Example:

SCD171-0221-2-4-135HA30-HP246

Tool diameter $d_1 = 2.21$ mm

Dimensions of configurable series

d_1 h6	d_2 h5	l_1	l_2	l_3	l_4
1,00 - 1,20	3	75	38	36	28
1,21 - 1,50	3	85	50	47	28
1,51 - 1,80	3	95	59	56	28
1,81 - 2,10	3	100	66	62	28
2,11 - 2,50	3	115	80	76	28
2,51 - 2,99	3	130	96	91	28

Dimensions in mm.

For cutting data recommendations, see end of chapter.

Special designs and other coatings available upon request.

MEGA-Deep-Drill-Steel

Solid carbide twist drill
SCD701 (30xD), internal coolant supply

Design:
 Drill diameter: 3.00 - 12.00 mm
 Bore tolerance: IT9 (available)
 Shank form: HA
 Cutting material: HP400
 Number of cutting edges: 2
 Tip angle: 137°
 Helix angle: 30°
 Special features: Head coating

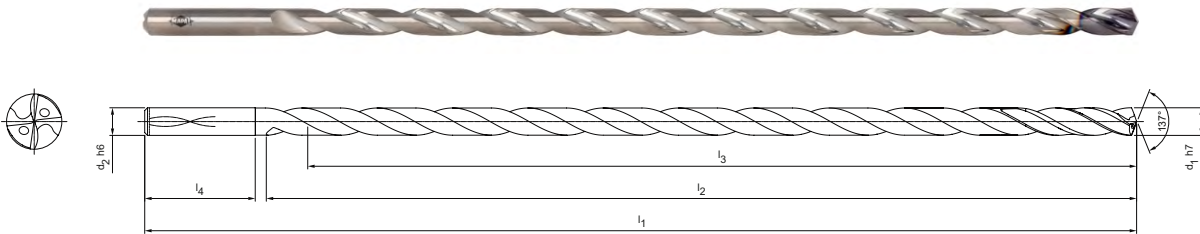

Product configuration bar: P 1 2 3 4 5 6 M 1 2 3 K 1 2 3 N 1 2 3 4 S 1 2 3 4 5 H 1 2 3

IT9 30xD HA DIN 6535

Preferred series available from stock

Dimensions						Shank form HA	
d ₁ h7	d ₂ h6	l ₁	l ₂	l ₃	l ₄	Specification	Order no.
3,00	4,00	143	111	105	28	SCD701-0300-2-4-137HA30-HP400	31459766
3,50	4,00	158	126	120	28	SCD701-0350-2-4-137HA30-HP400	31459767
4,00	4,00	158	126	120	28	SCD701-0400-2-4-137HA30-HP400	31459768
4,50	5,00	174	142	135	28	SCD701-0450-2-4-137HA30-HP400	31459769
5,00	5,00	190	158	150	28	SCD701-0500-2-4-137HA30-HP400	31459770
5,50	6,00	214	174	165	36	SCD701-0550-2-4-137HA30-HP400	31459771
6,00	6,00	229	189	180	36	SCD701-0600-2-4-137HA30-HP400	31459772
6,50	8,00	261	221	210	36	SCD701-0650-2-4-137HA30-HP400	31459773
7,00	8,00	261	221	210	36	SCD701-0700-2-4-137HA30-HP400	31459774
8,00	8,00	292	252	240	36	SCD701-0800-2-4-137HA30-HP400	31459775
9,00	10,00	328	284	270	40	SCD701-0900-2-4-137HA30-HP400	31459776
10,00	10,00	359	315	300	40	SCD701-1000-2-4-137HA30-HP400	31459777
11,00	12,00	396	347	330	45	SCD701-1100-2-4-137HA30-HP400	31459778
12,00	12,00	427	378	360	45	SCD701-1200-2-4-137HA30-HP400	31459779

Configurable features

Diameter:
Diameter in increments of 0.01 mm freely selectable

Specification:
SCD701-[diameter]-2-4-137HA30-HP400

Example:
SCD701-0735-2-4-137HA30-HP400
Tool diameter d₁ = 7.35 mm

Dimensions of configurable series h7

d ₁ min.	d ₁ max.	d ₂ h6	l ₁	l ₂	l ₃	l ₄
3,00	3,49	4,00	143	111	105	28
3,50	4,00	4,00	158	126	120	28
4,01	4,50	5,00	174	142	135	28
4,51	5,00	5,00	190	158	150	28
5,01	5,50	6,00	214	174	165	36
5,51	6,00	6,00	229	189	180	36
6,01	7,00	8,00	261	221	210	36
7,01	8,00	8,00	292	252	240	36
8,01	9,00	10,00	328	284	270	40
9,01	10,00	10,00	359	315	300	40
10,01	11,00	12,00	396	347	330	45
11,01	12,00	12,00	427	378	360	45

Dimensions in mm.
 For cutting data recommendations and coolant specifications, as well as information on the deep hole drilling process, see chapter "Technical Appendix".
 Special designs and other coatings available upon request.

MEGA-Deep-Drill-Steel

Solid carbide twist drill
SCD701 (40xD), internal coolant supply

Design:
 Drill diameter: 3.00 - 9.00 mm
 Bore tolerance: IT9 (available)
 Shank form: HA
 Cutting material: HP400
 Number of cutting edges: 2
 Tip angle: 134°
 Helix angle: 30°
 Special features: Head coating

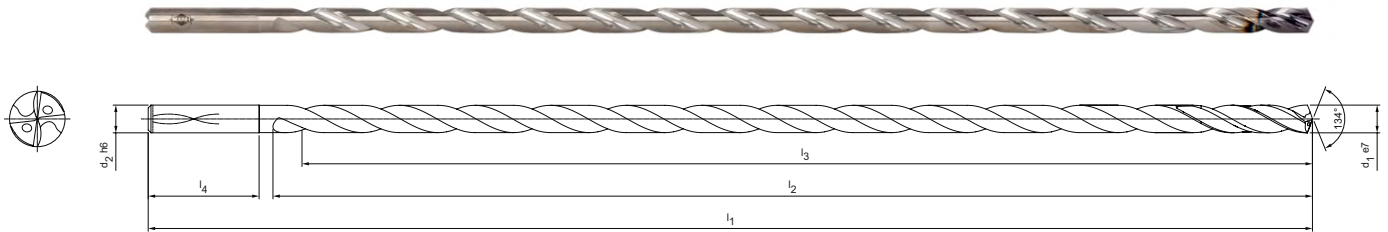

P
1
2
3
4
5
6
M
1
2
3
K
1
2
3
N
1
2
3
4
S
1
2
3
4
5
H
1
2
3

Preferred series available from stock

Dimensions						Shank form HA	
d ₁ e7	d ₂ h6	l ₁	l ₂	l ₃	l ₄	Specification	Order no.
3,00	4,00	178	146	140	28	SCD701-0300-2-4-134HA40-HP400	31459780
3,50	4,00	198	166	160	28	SCD701-0350-2-4-134HA40-HP400	31459781
4,00	4,00	198	166	160	28	SCD701-0400-2-4-134HA40-HP400	31459782
4,50	5,00	219	187	180	28	SCD701-0450-2-4-134HA40-HP400	31459783
5,00	5,00	240	208	200	28	SCD701-0500-2-4-134HA40-HP400	31459784
6,00	6,00	289	249	240	36	SCD701-0600-2-4-134HA40-HP400	31459785
7,00	8,00	331	291	280	36	SCD701-0700-2-4-134HA40-HP400	31459786
8,00	8,00	372	332	320	36	SCD701-0800-2-4-134HA40-HP400	31459787
9,00	10,00	418	374	360	40	SCD701-0900-2-4-134HA40-HP400	31459788

Configurable features

Diameter:
Diameter in increments of 0.01 mm freely selectable

Specification:
SCD701-[Diameter]-2-4-134HA40-HP400

Example:
SCD701-0735-2-4-134HA40-HP400
Tool diameter d₁ = 7.35 mm

Dimensions of configurable series e7

d ₁ min.	d ₁ max.	d ₂ h6	l ₁	l ₂	l ₃	l ₄
3,00	3,49	4,00	178	146	140	28
3,50	4,00	4,00	198	166	160	28
4,01	4,50	5,00	219	187	180	28
4,51	5,00	5,00	240	208	200	28
5,01	5,50	6,00	269	229	220	36
5,51	6,00	6,00	289	249	240	36
6,01	7,00	8,00	331	291	280	36
7,01	8,00	8,00	372	332	320	36
8,01	9,00	10,00	418	374	360	40

Dimensions in mm.
 For cutting data recommendations and coolant specifications, as well as information on the deep hole drilling process, see chapter "Technical Appendix".
 Special designs and other coatings available upon request.

MEGA-Drill-Reamer-Pyramid

Drill reamer

SDR201 (5xD), internal coolant supply, with pyramid tip

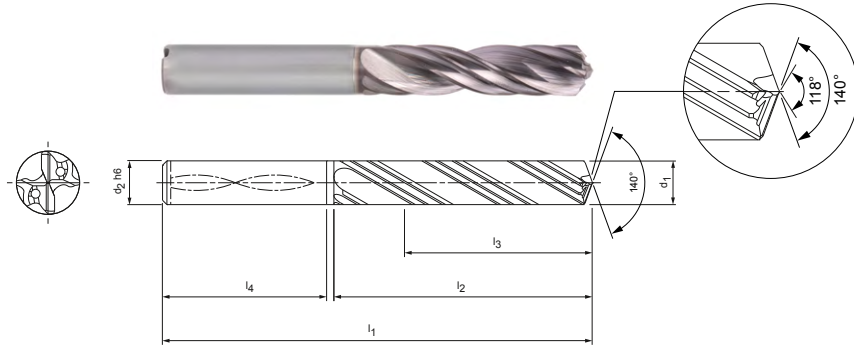

Design:

- Drill diameter: 3.970 - 16.050 mm
- Bore tolerance: ≥ IT 7
- Cutting material: HP358
- Number of cutting edges: 2
- Number of guiding chamfers: 4
- Point geometry: Specific lead geometry with pyramid
- Tip angle: 140°
- Helix angle: 30°
- Special features: With pyramid tip, inclined bore entrance up to max. 10°

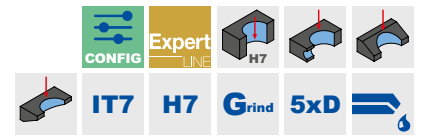

Stocked preferred series in shank form HA

Dimensions							Shank form HA	
d ₁ (±0.003)	Bore diameter * min. - max.	d ₂ h6	l ₁	l ₂	l ₃	l ₄	Specification	Order no.
5,98	5,975 - 5,993	6	91	53	43	36	SDR201G-5.980+3-3-HA05-HP835	31200031
6,00	5,995 - 6,013	6	91	53	43	36	SDR201G-6.000+3-3-HA05-HP835	31200033
6,01	6,005 - 6,023	6	91	53	43	36	SDR201G-6.010+3-3-HA05-HP835	31200034
6,02	6,015 - 6,033	6	91	53	43	36	SDR201G-6.020+3-3-HA05-HP835	31200035
7,98	7,975 - 7,993	8	91	53	43	36	SDR201G-7.980+3-3-HA05-HP835	31200043
8,00	7,995 - 8,013	8	91	53	43	36	SDR201G-8.000+3-3-HA05-HP835	31200045
8,01	8,005 - 8,023	8	91	53	43	36	SDR201G-8.010+3-3-HA05-HP835	31200046
8,02	8,015 - 8,033	8	91	53	43	36	SDR201G-8.020+3-3-HA05-HP835	31200047
9,54	9,535 - 9,553	10	103	61	49	40	SDR201G-9.540+3-3-HA05-HP835	31200053
10,00	9,995 - 10,013	10	103	61	49	40	SDR201G-10.000+3-3-HA05-HP835	31200057
10,01	10,005 - 10,023	10	103	61	49	40	SDR201G-10.010+3-3-HA05-HP835	31200058
10,02	10,015 - 10,033	10	103	61	49	40	SDR201G-10.020+3-3-HA05-HP835	31200059
11,98	11,974 - 11,993	12	118	71	56	45	SDR201G-11.980+3-3-HA05-HP835	31200061
11,99	11,984 - 12,003	12	118	71	56	45	SDR201G-11.990+3-3-HA05-HP835	31200062
12,00	11,994 - 12,013	12	118	71	56	45	SDR201G-12.000+3-3-HA05-HP835	31200063
12,01	12,004 - 12,023	12	118	71	56	45	SDR201G-12.010+3-3-HA05-HP835	31200064
12,02	12,014 - 12,033	12	118	71	56	45	SDR201G-12.020+3-3-HA05-HP835	31200065
12,70	12,694 - 12,713	14	124	77	60	45	SDR201G-12.700+3-3-HA05-HP835	31200069

* We can only guarantee the specified bore tolerances will be achieved under perfect operating conditions and with radial run-out errors of < 10 µm. Workpiece, workpiece material and cooling lubricants can also influence the bore diameter.

Drill reamers for standard drill holes with tolerance H7

Dimensions							Shank form HA	
d_1	Bore diameter min. - max.	d_2 h6	l_1	l_2	l_3	l_4	Specification	Order no.
4 ^{H7}	4,000 - 4,012	6	74	36	29	36	SDR201-4.000H7-HA05-HP358	31200072
5 ^{H7}	5,000 - 5,012	6	91	53	43	36	SDR201-5.000H7-HA05-HP358	31200073
6 ^{H7}	6,000 - 6,012	6	91	53	43	36	SDR201-6.000H7-HA05-HP835	31200074
7 ^{H7}	7,000 - 7,015	8	91	53	43	36	SDR201-7.000H7-HA05-HP835	31200075
8 ^{H7}	8,000 - 8,015	8	91	53	43	36	SDR201-8.000H7-HA05-HP835	31200076
9 ^{H7}	9,000 - 9,015	10	103	61	49	40	SDR201-9.000H7-HA05-HP835	31200077
10 ^{H7}	10,000 - 10,015	10	103	61	49	40	SDR201-10.000H7-HA05-HP835	31200078
12 ^{H7}	12,000 - 12,018	12	118	71	56	45	SDR201-12.000H7-HA05-HP358	31200079
14 ^{H7}	14,000 - 14,018	14	124	77	60	45	SDR201-14.000H7-HA05-HP835	31200080
16 ^{H7}	16,000 - 16,018	16	133	83	63	48	SDR201-16.000H7-HA05-HP835	31200081

Configurable features



Bore diameter tolerance \geq IT8:

- Diameter freely selectable in increments of 0.001 mm
- Can be ordered in tolerance \geq IT8



Specification:
SDR201-[Diameter][Tolerance]-HA05-HP835

G variants:

- Diameter freely selectable in increments of 0.001 mm
- Can be ordered from tolerances \geq 5 μ m

G variant specification:
SDR201-[Diameter][Tolerance]-HA05-HP835

Dimensions of configurable series IT7 and G variants

d_1	d_2 h6	l_1	l_1	l_3	l_4
3,970 - 4,800	6	74	36	29	36
4,801 - 6,050	6	91	53	43	36
6,051 - 8,050	8	91	53	43	36
8,051 - 10,050	10	103	61	49	40
10,051 - 12,050	12	118	71	56	45
12,051 - 14,050	14	124	77	60	45
14,051 - 16,050	16	133	83	63	48

IT8 tolerance example:

SDR201-11.530H8-HA05-HP835

Bore diameter $d_1 = 11.530$ H8

G variant example:

SDR201G-11.530+3-3-HA05-HP835

Special tool diameter $d_1 = 11.530 \pm 3 \mu$ m

Dimensions in mm.

For cutting data recommendations, see end of chapter.

Special designs and other coatings available upon request.

TRITAN-DRILL-REAMER

The most precise solution for drilling and reaming in one machining step

Combining several machining steps in one tool is a proven way to manufacture as economically as possible. For example, bores can be drilled and reamed simultaneously with the Tritan-Drill-Reamer from MAPAL.

MAPAL has developed the Tritan-Drill-Reamer in order to produce fitting bores even more accurately using just one tool.

With six margin lands for excellent guiding properties, precision-ground chip flutes with matching groove shapes for good chip removal and a self-centring chisel edge, the new Tritan-Drill-Reamer is thoroughly convincing.

The self-centring chisel edge ensures good positioning accuracy and improved tapping behaviour. Three cutting edges guarantee optimal roundness of the fit bore and highest performance. The guiding chamfers produce best-quality surfaces.

FEATURES

- Combination of drilling and reaming
- Length versions 3xD and 5xD
- Three cutting edges and six guiding chamfers
- With internal cooling
- Degree of tolerance ± 0.003 mm and H7

ADVANTAGES

- Reduced productive and non-productive times
- Best performance and highest levels of accuracy
- High degree of positional accuracy
- Optimal roundness

Tool features in detail

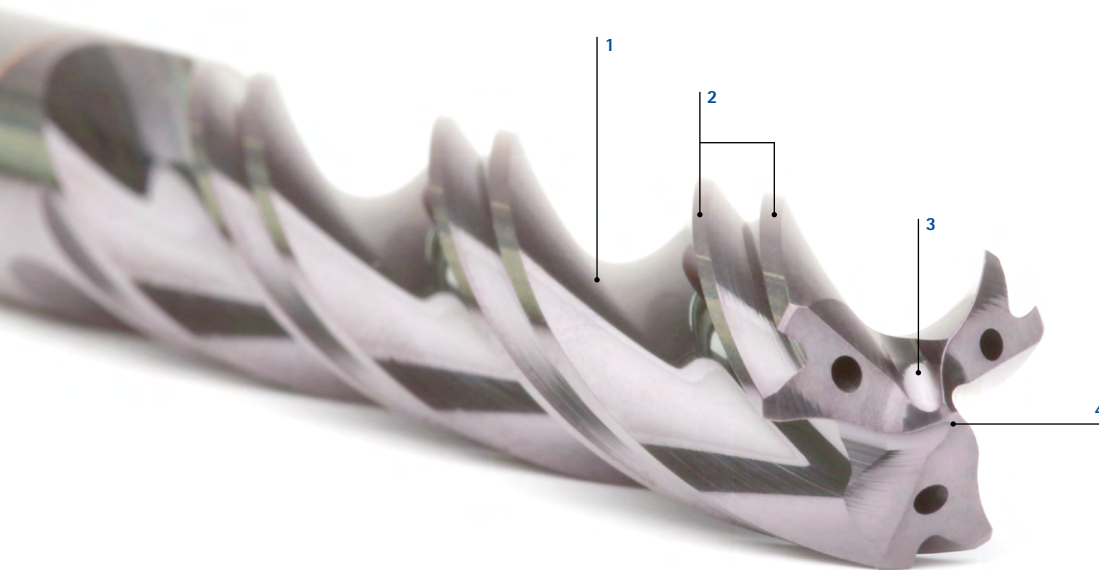

- 1 Finely ground groove profile
- 2 Six guiding chamfers
- 3 Innovative point thinning
- 4 Self-centring chisel edge



Six guiding chamfers

- For excellent guiding properties
- For the production of fitting bores using a single tool with maximum economic efficiency and accuracy



Innovative centre point

- Self-centring chisel edges for very good positional accuracy and improved tapping

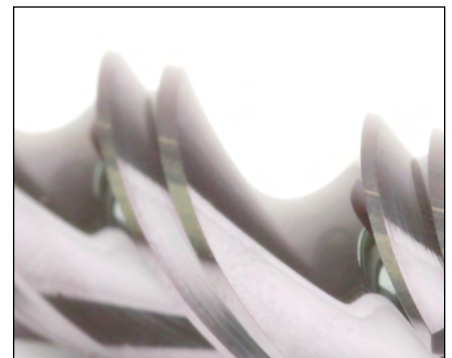

Finely ground groove profile

- Finely ground chip flutes with adapted groove shape for very good chip removal



Comparison Tritan-Drill-Reamer and double-edge solution

Diameter deviation over the tools entire diameter (42CrMoS4)

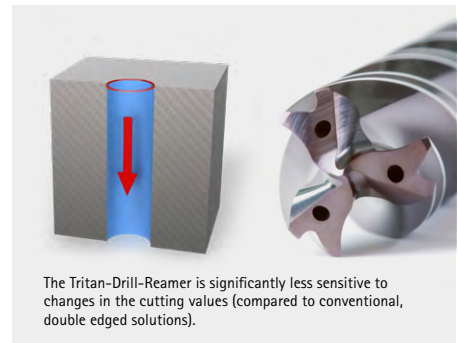
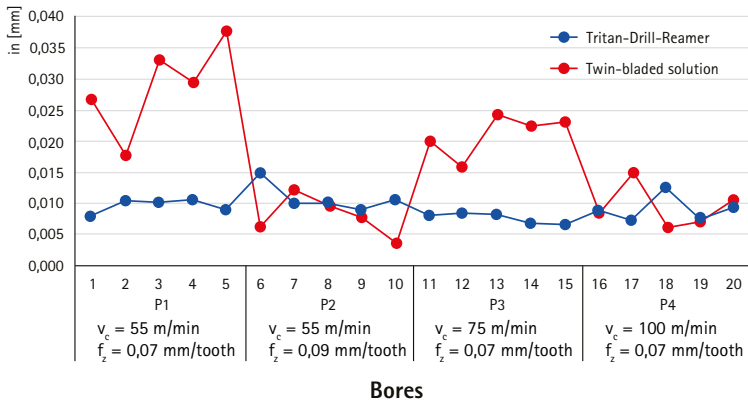

Circularity after 600 bores

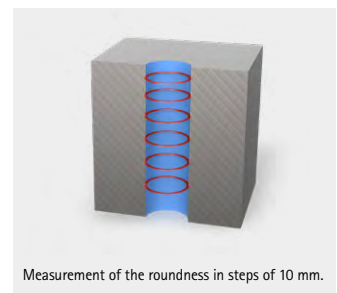
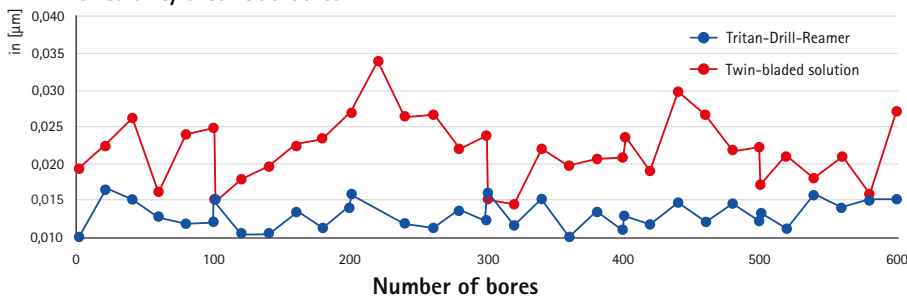

Tritan-Drill-Reamer

Drill reamer
SDR301G (3xD), internal coolant supply

Design:
 Drill diameter: 3.80 - 20.05 mm
 Bore tolerance: $\geq IT 7$
 Cutting material: HP358
 Number of cutting edges: 3
 Number of guiding chamfers: 6
 Tip angle: 140°
 Helix angle: 30°

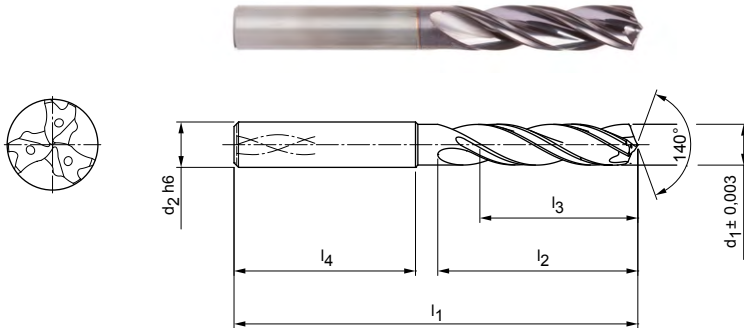

Stocked preferred series in shank form HA

Dimensions						Shank form HA	
$d_1 \pm 0.003$	$d_2 h6$	l_1	l_2	l_3	l_4	Specification	Order no.
3,99	6	66	24	17	36	SDR301G-3.990+3-3-HA03-HP358	31196569
4,00	6	66	24	17	36	SDR301G-4.000+3-3-HA03-HP358	31196570
4,01	6	66	24	17	36	SDR301G-4.010+3-3-HA03-HP358	31196571
4,99	6	66	28	20	36	SDR301G-4.990+3-3-HA03-HP358	31196575
5,00	6	66	28	20	36	SDR301G-5.000+3-3-HA03-HP358	31196576
5,01	6	66	28	20	36	SDR301G-5.010+3-3-HA03-HP358	31196577
5,02	6	66	28	20	36	SDR301G-5.020+3-3-HA03-HP358	31196578
5,99	6	66	28	20	36	SDR301G-5.990+3-3-HA03-HP358	31196581
6,00	6	66	28	20	36	SDR301G-6.000+3-3-HA03-HP358	31196582
6,01	6	66	28	20	36	SDR301G-6.010+3-3-HA03-HP358	31196583
7,99	8	79	41	29	36	SDR301G-7.990+3-3-HA03-HP358	31196587
8,00	8	79	41	29	36	SDR301G-8.000+3-3-HA03-HP358	31196588
8,01	8	79	41	29	36	SDR301G-8.010+3-3-HA03-HP358	31196589
9,99	10	89	47	35	40	SDR301G-9.990+3-3-HA03-HP358	31196593
10,00	10	89	47	35	40	SDR301G-10.000+3-3-HA03-HP358	31196594
10,01	10	89	47	35	40	SDR301G-10.010+3-3-HA03-HP358	31196595
10,02	10	89	47	35	40	SDR301G-10.020+3-3-HA03-HP358	31196596
11,99	12	102	55	40	45	SDR301G-11.990+3-3-HA03-HP358	31196599
12,00	12	102	55	40	45	SDR301G-12.000+3-3-HA03-HP358	31196600
12,01	12	102	55	40	45	SDR301G-12.010+3-3-HA03-HP358	31196601
13,99	14	107	60	43	45	SDR301G-13.990+3-3-HA03-HP358	31196605
14,00	14	107	60	43	45	SDR301G-14.000+3-3-HA03-HP358	31196606
14,01	14	107	60	43	45	SDR301G-14.010+3-3-HA03-HP358	31196607
15,99	16	115	65	45	48	SDR301G-15.990+3-3-HA03-HP358	31196611
16,00	16	115	65	45	48	SDR301G-16.000+3-3-HA03-HP358	31196612
16,01	16	115	65	45	48	SDR301G-16.010+3-3-HA03-HP358	31196613

Tritan-Drill-Reamer | Drill reamer SDR301G (3xD), internal coolant supply

Configurable features



Diameter:
Diameter in increments of
0.001 mm freely selectable

**Specification:**

SDR301G-[diameter]+3-3-HA03-HP358

Example:

SDR301G-4.001+3-3-HA03-HP358

Tool diameter $d_1 = 4.001$ mm

Dimensions of configurable series

d_1 min.	d_1 max.	d_2 h6	l_1	l_2	l_3	l_4
3,800	4,700	6	66	24	17	36
4,701	6,050	6	66	28	20	36
6,051	8,050	8	79	41	29	36
8,051	10,050	10	89	47	35	40
10,051	12,050	12	102	55	40	45
12,970	14,050	14	107	60	43	45
14,970	16,050	16	115	65	45	48
16,800	18,050	18	123	73	51	48
18,700	20,050	20	131	79	55	50

Dimensions in mm.

For tolerance class fit bores up to max. IT7, with sufficient machine stability and cooling.

For help in calculating the optimum nominal diameter for different fitting bores, please refer to the information field at the end of the chapter.

For cutting data recommendations, see end of chapter.

Special designs and other coatings available upon request.

Tritan-Drill-Reamer

Drill reamer
SDR301 (3xD), internal coolant supply

Design:
 Drill diameter: 4.00 - 16.00 mm
 Bore tolerance: \geq IT 7
 Cutting material: HP358
 Number of cutting edges: 3
 Number of guiding chamfers: 6
 Tip angle: 140°
 Helix angle: 30°

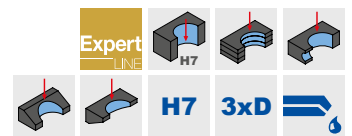
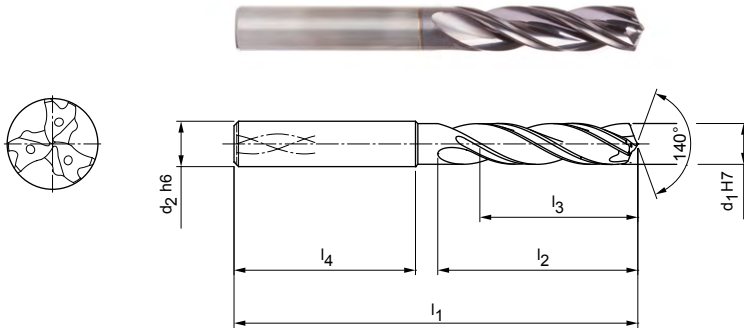

Stocked preferred series in shank form HA

Dimensions						Shank form HA	
d ₁ H7	d ₂ h6	l ₁	l ₂	l ₃	l ₄	Specification	Order no.
4,00	6	66	24	17	36	SDR301-4.000H7-HA03-HP358	31196337
5,00	6	66	28	20	36	SDR301-5.000H7-HA03-HP358	31196338
6,00	6	66	28	20	36	SDR301-6.000H7-HA03-HP358	31196339
8,00	8	79	41	29	36	SDR301-8.000H7-HA03-HP358	31196560
10,00	10	89	47	35	40	SDR301-10.000H7-HA03-HP358	31196561
12,00	12	102	55	40	45	SDR301-12.000H7-HA03-HP358	31196562
14,00	14	107	60	43	45	SDR301-14.000H7-HA03-HP358	31196563
16,00	16	115	65	45	48	SDR301-16.000H7-HA03-HP358	31196564

Dimensions in mm.
 For tolerance class fit bores of H7, with sufficient machine stability and cooling.
 For cutting data recommendations, see end of chapter.
 Special designs and other coatings available upon request.

Tritan-Drill-Reamer

Drill reamer
SDR301G (5xD), internal coolant supply

Design:
 Drill diameter: 3.80 - 20.05 mm
 Bore tolerance: $\geq IT 7$
 Cutting material: HP358
 Number of cutting edges: 3
 Number of guiding chamfers: 6
 Tip angle: 140°
 Helix angle: 30°

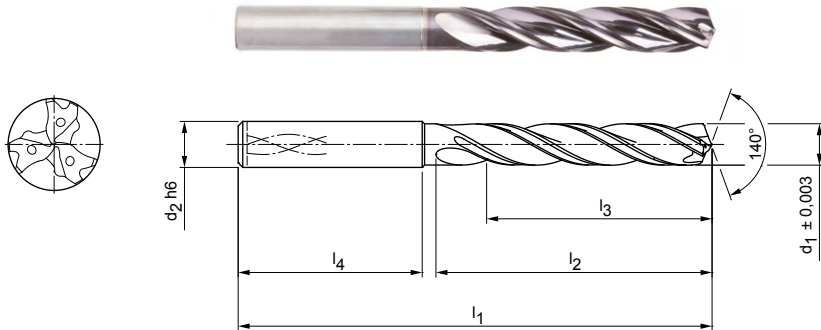

Stocked preferred series in shank form HA

Dimensions						Shank form HA	
$d_1 \pm 0.003$	$d_2 h6$	l_1	l_2	l_3	l_4	Specification	Order no.
3,99	6	74	36	29	36	SDR301G-3.990+3-3-HA05-HP358	31196639
4,00	6	74	36	29	36	SDR301G-4.000+3-3-HA05-HP358	31196640
4,01	6	74	36	29	36	SDR301G-4.010+3-3-HA05-HP358	31196641
4,02	6	74	36	29	36	SDR301G-4.020+3-3-HA05-HP358	31196642
4,99	6	82	44	35	36	SDR301G-4.990+3-3-HA05-HP358	31196645
5,00	6	82	44	35	36	SDR301G-5.000+3-3-HA05-HP358	31196646
5,01	6	82	44	35	36	SDR301G-5.010+3-3-HA05-HP358	31196647
5,99	6	82	44	35	36	SDR301G-5.990+3-3-HA05-HP358	31196651
6,00	6	82	44	35	36	SDR301G-6.000+3-3-HA05-HP358	31196652
6,01	6	82	44	35	36	SDR301G-6.010+3-3-HA05-HP358	31196653
7,99	8	91	53	43	36	SDR301G-7.990+3-3-HA05-HP358	31196658
8,00	8	91	53	43	36	SDR301G-8.000+3-3-HA05-HP358	31196659
8,01	8	91	53	43	36	SDR301G-8.010+3-3-HA05-HP358	31196660
8,02	8	91	53	43	36	SDR301G-8.020+3-3-HA05-HP358	31196661
9,99	10	103	61	49	40	SDR301G-9.990+3-3-HA05-HP358	31196664
10,00	10	103	61	49	40	SDR301G-10.000+3-3-HA05-HP358	31196665
10,01	10	103	61	49	40	SDR301G-10.010+3-3-HA05-HP358	31196666
11,99	12	118	71	59	45	SDR301G-11.990+3-3-HA05-HP358	31196670
12,00	12	118	71	59	45	SDR301G-12.000+3-3-HA05-HP358	31196671
12,01	12	118	71	59	45	SDR301G-12.010+3-3-HA05-HP358	31196672
13,99	14	124	77	60	45	SDR301G-13.990+3-3-HA05-HP358	31196676
14,00	14	124	77	60	45	SDR301G-14.000+3-3-HA05-HP358	31196677
14,01	14	124	77	60	45	SDR301G-14.010+3-3-HA05-HP358	31196678
15,99	16	133	83	63	48	SDR301G-15.990+3-3-HA05-HP358	31196682
16,00	16	133	83	63	48	SDR301G-16.000+3-3-HA05-HP358	31196683
16,01	16	133	83	63	48	SDR301G-16.010+3-3-HA05-HP358	31196684

Continued on next page.

Tritan-Drill-Reamer | Drill reamer SDR301G (5xD), internal coolant supply

Configurable features



Diameter:
Diameter in increments of 0.001 mm freely selectable



Specification:
SDR301G-[diameter]+3-3-HA05-HP358

Example:

SDR301G-04001+3-3-HA05-HP358

Tool diameter $d_1 = 4.001$ mm

Dimensions of configurable series

d_1 min.	d_1 max.	d_2 h6	l_1	l_2	l_3	l_4
3,800	4,700	6	74	36	29	36
4,701	6,050	6	82	44	35	36
6,051	8,050	8	91	53	43	36
8,051	10,050	10	103	61	49	40
10,051	12,050	12	118	71	56	45
12,970	14,050	14	124	77	60	45
14,970	16,050	16	133	83	63	48
16,800	18,050	18	143	93	71	48
18,700	20,050	20	153	101	77	50

Dimensions in mm.

For tolerance class fit bores up to max. IT7, with sufficient machine stability and cooling.

For help in calculating the optimum nominal diameter for different fitting bores, please refer to the information field at the end of the chapter.

For cutting data recommendations, see end of chapter.

Special designs and other coatings available upon request.

Tritan-Drill-Reamer

Drill reamer
SDR301 (5xD), internal coolant supply

Design:
 Drill diameter: 4.00 - 20.00 mm
 Bore tolerance: \geq IT 7
 Cutting material: HP358
 Number of cutting edges: 3
 Number of guiding chamfers: 6
 Tip angle: 140°
 Helix angle: 30°

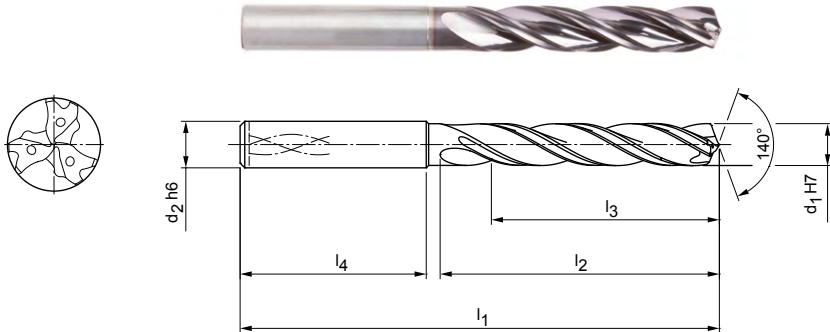

Stocked preferred series in shank form HA

Dimensions						Shank form HA	
d ₁ H7	d ₂ h6	l ₁	l ₂	l ₃	l ₄	Specification	Order no.
4,00	6	74	36	29	36	SDR301-4.000H7-HA05-HP358	31196627
5,00	6	82	44	35	36	SDR301-5.000H7-HA05-HP358	31196628
6,00	6	82	44	35	36	SDR301-6.000H7-HA05-HP358	31196629
8,00	8	91	53	43	36	SDR301-8.000H7-HA05-HP358	31196630
10,00	10	103	61	49	40	SDR301-10.000H7-HA05-HP358	31196631
12,00	12	118	71	56	45	SDR301-12.000H7-HA05-HP358	31196632
14,00	14	124	77	60	45	SDR301-14.000H7-HA05-HP358	31196633
16,00	16	133	83	63	48	SDR301-16.000H7-HA05-HP358	31196634
18,00	18	143	93	71	48	SDR301-18.000H7-HA05-HP358	31196635
20,00	20	153	101	77	50	SDR301-20.000H7-HA05-HP358	31196636

Dimensions in mm.
 For tolerance class fit bores of H7, with sufficient machine stability and cooling.
 For cutting data recommendations, see end of chapter.
 Special designs and other coatings available upon request.

QTD indexable inserts

Made from solid carbide, internal coolant supply
Type O1 - Steel

Design:
 Drill diameter: 9.00 - 50.00 mm
 Bore tolerance: $\geq IT 10$
 Cutting material: HP240
 Number of cutting edges: 2
 Number of guiding chamfers: 2
 Tip angle: 135°

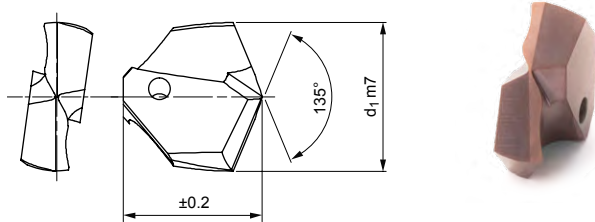

Preferred series in stock

d ₁ from 9.00 to 15.50			
d ₁ m7	Tool holder size D	Specification	Order no.
9,00	9	QTD-2F01-0900-HP240	30615635
9,50	9,5	QTD-2F01-0950-HP240	30615636
10,00	10	QTD-2F01-1000-HP240	30615638
10,20	10	QTD-2F01-1020-HP240	30646024
10,50	10,5	QTD-2F01-1050-HP240	30615639
10,70	10,5	QTD-2F01-1070-HP240	30615640
11,00	11	QTD-2F01-1100-HP240	30615641
11,50	11,5	QTD-2F01-1150-HP240	30615642
12,00	12	QTD-2F01-1200-HP240	30615644
12,50	12,5	QTD-2F01-1250-HP240	30615645
12,70	12,5	QTD-2F01-1270-HP240	30615646
12,80	12,5	QTD-2F01-1280-HP240	30646043
13,00	13	QTD-2F01-1300-HP240	30572990
13,10	13	QTD-2F01-1310-HP240	30646045
13,30	13	QTD-2F01-1330-HP240	30646047
13,40	13	QTD-2F01-1340-HP240	30646048
13,50	13,5	QTD-2F01-1350-HP240	30572991
13,80	13,5	QTD-2F01-1380-HP240	30646050
13,90	13,5	QTD-2F01-1390-HP240	30646051
14,00	14	QTD-2F01-1400-HP240	30572993
14,10	14	QTD-2F01-1410-HP240	30646052
14,20	14	QTD-2F01-1420-HP240	30646053
14,30	14	QTD-2F01-1430-HP240	30646055
14,50	14,5	QTD-2F01-1450-HP240	30572994
14,60	14,5	QTD-2F01-1460-HP240	30646057
14,70	14,5	QTD-2F01-1470-HP240	30572995
14,80	14,5	QTD-2F01-1480-HP240	30646058
14,90	14,5	QTD-2F01-1490-HP240	30646059
15,00	15	QTD-2F01-1500-HP240	30572997
15,10	15	QTD-2F01-1510-HP240	30646060
15,20	15	QTD-2F01-1520-HP240	30646061
15,25	15	QTD-2F01-1525-HP240	30572998
15,50	15	QTD-2F01-1550-HP240	30572999

d ₁ from 15.70 to 19.50			
d ₁ m7	Tool holder size D	Specification	Order no.
15,70	15	QTD-2F01-1570-HP240	30573000
15,80	15	QTD-2F01-1580-HP240	30646066
15,90	15	QTD-2F01-1590-HP240	30646068
16,00	16	QTD-2F01-1600-HP240	30573001
16,10	16	QTD-2F01-1610-HP240	30573003
16,20	16	QTD-2F01-1620-HP240	30646069
16,25	16	QTD-2F01-1625-HP240	30573004
16,30	16	QTD-2F01-1630-HP240	30610882
16,40	16	QTD-2F01-1640-HP240	30646071
16,50	16	QTD-2F01-1650-HP240	30573005
16,60	16	QTD-2F01-1660-HP240	30646072
16,70	16	QTD-2F01-1670-HP240	30573006
16,80	16	QTD-2F01-1680-HP240	30646074
16,90	16	QTD-2F01-1690-HP240	30646075
17,00	17	QTD-2F01-1700-HP240	30573009
17,10	17	QTD-2F01-1710-HP240	30646076
17,20	17	QTD-2F01-1720-HP240	30646077
17,30	17	QTD-2F01-1730-HP240	30646078
17,40	17	QTD-2F01-1740-HP240	30646079
17,50	17	QTD-2F01-1750-HP240	30573010
17,60	17	QTD-2F01-1760-HP240	30646081
17,70	17	QTD-2F01-1770-HP240	30573011
17,80	17	QTD-2F01-1780-HP240	30646082
17,90	17	QTD-2F01-1790-HP240	30646083
18,00	18	QTD-2F01-1800-HP240	30573012
18,10	18	QTD-2F01-1810-HP240	30646084
18,50	18	QTD-2F01-1850-HP240	30573014
18,60	18	QTD-2F01-1860-HP240	30646088
18,70	18	QTD-2F01-1870-HP240	30573015
18,80	18	QTD-2F01-1880-HP240	30646089
18,90	18	QTD-2F01-1890-HP240	30646090
19,00	19	QTD-2F01-1900-HP240	30573016
19,50	19	QTD-2F01-1905-HP240	30646091

Indexable inserts QTD made from solid carbide, internal coolant supply – Type 01

d ₁ from 19.10 to 24.70				d ₁ from 24.75 to 42.60			
d ₁ m7	Tool holder size D	Specification	Order no.	d ₁ m7	Tool holder size D	Specification	Order no.
19,10	19	QTD-2F01-1910-HP240	30646092	24,75	24	QTD-2F01-2475-HP240	30573046
19,20	19	QTD-2F01-1920-HP240	30573017	24,80	24	QTD-2F01-2480-HP240	30660662
19,25	19	QTD-2F01-1925-HP240	30573018	25,00	25	QTD-2F01-2500-HP240	30573047
19,30	19	QTD-2F01-1930-HP240	30646094	25,40	25	QTD-2F01-2540-HP240	30573048
19,50	19	QTD-2F01-1950-HP240	30573020	25,50	25	QTD-2F01-2550-HP240	30573049
19,60	19	QTD-2F01-1960-HP240	30646095	25,70	25	QTD-2F01-2570-HP240	30573050
19,70	19	QTD-2F01-1970-HP240	30573021	25,80	25	QTD-2F01-2580-HP240	30584730
19,75	19	QTD-2F01-1975-HP240	30573022	26,00	26	QTD-2F01-2600-HP240	30573051
19,80	19	QTD-2F01-1980-HP240	30646096	26,50	26	QTD-2F01-2650-HP240	30573052
19,90	19	QTD-2F01-1990-HP240	30646097	27,00	27	QTD-2F01-2700-HP240	30573053
20,00	20	QTD-2F01-2000-HP240	30573023	27,50	27	QTD-2F01-2750-HP240	30573054
20,40	20	QTD-2F01-2040-HP240	30573024	27,75	27	QTD-2F01-2775-HP240	30573055
20,50	20	QTD-2F01-2050-HP240	30573025	28,00	28	QTD-2F01-2800-HP240	30573056
20,70	20	QTD-2F01-2070-HP240	30573026	28,50	28	QTD-2F01-2850-HP240	30573058
20,75	20	QTD-2F01-2075-HP240	30573027	29,00	29	QTD-2F01-2900-HP240	30573059
21,00	21	QTD-2F01-2100-HP240	30573028	29,50	29	QTD-2F01-2950-HP240	30573060
21,50	21	QTD-2F01-2150-HP240	30573029	29,80	29	QTD-2F01-2980-HP240	30728319
21,70	21	QTD-2F01-2170-HP240	30573030	30,00	30	QTD-2F01-3000-HP240	30573062
22,00	22	QTD-2F01-2200-HP240	30573031	30,25	30	QTD-2F01-3025-HP240	30573063
22,25	22	QTD-2F01-2225-HP240	30573032	30,50	30	QTD-2F01-3050-HP240	30573064
22,50	22	QTD-2F01-2250-HP240	30573034	31,00	31	QTD-2F01-3100-HP240	30573066
22,70	22	QTD-2F01-2270-HP240	30573035	31,50	31	QTD-2F01-3150-HP240	30573067
22,75	22	QTD-2F01-2275-HP240	30573036	32,00	32	QTD-2F01-3200-HP240	30573068
23,00	23	QTD-2F01-2300-HP240	30573037	33,00	33	QTD-2F01-3300-HP240	30649656
23,25	23	QTD-2F01-2325-HP240	30573038	34,00	34	QTD-2F01-3400-HP240	30649657
23,50	23	QTD-2F01-2350-HP240	30573039	35,00	35	QTD-2F01-3500-HP240	30649658
23,75	23	QTD-2F01-2375-HP240	30573042	36,00	36	QTD-2F01-3600-HP240	30649659
24,00	24	QTD-2F01-2400-HP240	30573043	37,00	37	QTD-2F01-3700-HP240	30649660
24,30	24	QTD-2F01-2430-HP240	30646105	38,00	37	QTD-2F01-3800-HP240	30649661
24,50	24	QTD-2F01-2450-HP240	30573044	40,00	39	QTD-2F01-4000-HP240	30657233
24,70	24	QTD-2F01-2470-HP240	30573045	42,00	41	QTD-2F01-4200-HP240	30657235

Configurable features



Diameter:
Diameter in increments of
0.01 mm freely selectable



Specification:

QTD-2F01-[diameter]-HP240

Example:

QTD-2F01-0901-HP240

Tool diameter d₁ = 9.01 mm

Dimensions of configurable series

d ₁ min.	d ₁ max.
9,00	50,00

Dimensions in mm.

For cutting data recommendations, see end of chapter.

Special designs and other coatings available upon request.

QTS indexable insert holder

With prism mounting for QTD indexable inserts
QTS100S, internal coolant supply

Design:

For diameter:

9.00 - 50.99 mm

Shank form:

According to ISO 9766

Changing system:

Prism mounting, possible to replace cutting edges on the machine

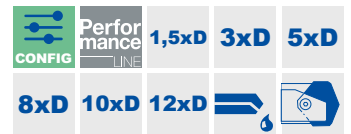
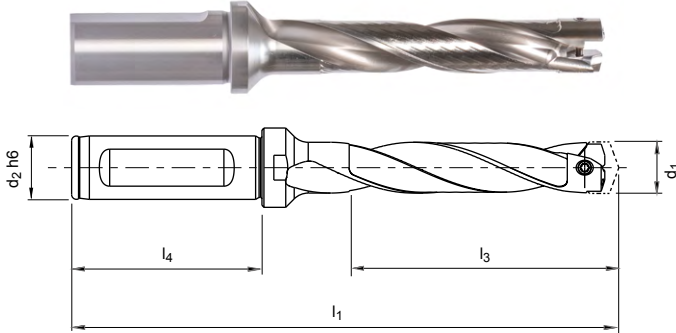

Preferred series in stock

Tool holder size D	Dimensions					Specification	Order no.
	Diameter range Indexable insert d ₁	d ₂ h6	l ₁	l ₃	l ₄		
9,00	9,00 - 9,49	12	110	48	45	QTS100S-0900-DR05-ZYL12-MN	30605484
9,50	9,50 - 9,99	12	113	50	45	QTS100S-0950-DR05-ZYL12-MN	30605485
10,00	10,00 - 10,49	16	99	32	48	QTS100S-1000-DR03-ZYL16-MN	30605476
10,00	10,00 - 10,49	16	120	53	48	QTS100S-1000-DR05-ZYL16-MN	30605486
10,50	10,50 - 10,99	16	122	55	48	QTS100S-1050-DR05-ZYL16-MN	30605487
11,00	11,00 - 11,49	16	126	58	48	QTS100S-1100-DR05-ZYL16-MN	30605488
11,00	11,00 - 11,49	16	160	92	48	QTS100S-1100-DR08-ZYL16-MN	30605498
11,50	11,50 - 11,99	16	105	36	48	QTS100S-1150-DR03-ZYL16-MN	30605479
12,00	12,00 - 12,49	16	107	38	48	QTS100S-1200-DR03-ZYL16-MN	30605480
12,00	12,00 - 12,49	16	132	63	48	QTS100S-1200-DR05-ZYL16-MN	30605490
12,00	12,00 - 12,49	16	169	100	48	QTS100S-1200-DR08-ZYL16-MN	30605500
12,50	12,50 - 12,99	16	109	39	48	QTS100S-1250-DR03-ZYL16-MN	30605481
12,50	12,50 - 12,99	16	135	65	48	QTS100S-1250-DR05-ZYL16-MN	30605491
12,50	12,50 - 12,99	16	174	104	48	QTS100S-1250-DR08-ZYL16-MN	30605501
13,00	13,00 - 13,49	16	112	41	48	QTS100S-1300-DR03-ZYL16-MN	30572922
13,00	13,00 - 13,49	16	138	68	48	QTS100S-1300-DR05-ZYL16-MN	30572945
13,00	13,00 - 13,49	16	178	108	48	QTS100S-1300-DR08-ZYL16-MN	30572967
13,00	13,00 - 13,49	16	232	162	48	QTS100S-1300-DR12-ZYL16-MN	30598728
13,50	13,50 - 13,99	16	211	140	48	QTS100S-1350-DR10-ZYL16-MN	30826051
13,50	13,50 - 13,99	16	239	168	48	QTS100S-1350-DR12-ZYL16-MN	30598729
14,00	14,00 - 14,49	16	116	44	48	QTS100S-1400-DR03-ZYL16-MN	30572924
14,00	14,00 - 14,49	16	144	73	48	QTS100S-1400-DR05-ZYL16-MN	30572947
14,00	14,00 - 14,49	16	187	116	48	QTS100S-1400-DR08-ZYL16-MN	30572970
14,00	14,00 - 14,49	16	245	174	48	QTS100S-1400-DR12-ZYL16-MN	30598730
14,50	14,50 - 14,99	16	95	23	48	QTS100S-1450-DR01-ZYL16-MN	30572903
14,50	14,50 - 14,99	16	147	75	48	QTS100S-1450-DR05-ZYL16-MN	30572948
15,00	15,00 - 15,99	20	124	48	50	QTS100S-1500-DR03-ZYL20-MN	30572926
15,00	15,00 - 15,99	20	155	80	50	QTS100S-1500-DR05-ZYL20-MN	30572949
15,00	15,00 - 15,99	20	203	128	50	QTS100S-1500-DR08-ZYL20-MN	30572972
15,00	15,00 - 15,99	20	237	162	50	QTS100S-1500-DR10-ZYL20-MN	30826054
15,00	15,00 - 15,99	20	267	192	50	QTS100S-1500-DR12-ZYL20-MN	30598732
16,00	16,00 - 16,99	20	102	26	50	QTS100S-1600-DR01-ZYL20-MN	30572905
16,00	16,00 - 16,99	20	128	51	50	QTS100S-1600-DR03-ZYL20-MN	30572927
16,00	16,00 - 16,99	20	161	85	50	QTS100S-1600-DR05-ZYL20-MN	30572950

QTS indexable insert holder | QTS100, internal coolant supply

Tool holder size D	Dimensions					Specification	Order no.
	Diameter range Indexable insert d ₁	d ₂ h6	l ₁	l ₃	l ₄		
16,00	16,00 - 16,99	20	212	136	50	QTS100S-1600-DR08-ZYL20-MN	30572973
16,00	16,00 - 16,99	20	246	170	50	QTS100S-1600-DR10-ZYL20-MN	30826055
17,00	17,00 - 17,99	20	105	27	50	QTS100S-1700-DR01-ZYL20-MN	30572906
17,00	17,00 - 17,99	20	132	54	50	QTS100S-1700-DR03-ZYL20-MN	30572928
17,00	17,00 - 17,99	20	168	90	50	QTS100S-1700-DR05-ZYL20-MN	30572951
17,00	17,00 - 17,99	20	222	144	50	QTS100S-1700-DR08-ZYL20-MN	30572974
17,00	17,00 - 17,99	20	258	180	50	QTS100S-1700-DR10-ZYL20-MN	30826056
17,00	17,00 - 17,99	20	294	216	50	QTS100S-1700-DR12-ZYL20-MN	30598734
18,00	18,00 - 18,99	25	142	57	56	QTS100S-1800-DR03-ZYL25-MN	30572929
18,00	18,00 - 18,99	25	180	95	56	QTS100S-1800-DR05-ZYL25-MN	30572952
18,00	18,00 - 18,99	25	237	152	56	QTS100S-1800-DR08-ZYL25-MN	30572975
18,00	18,00 - 18,99	25	313	228	56	QTS100S-1800-DR12-ZYL25-MN	30598735
19,00	19,00 - 19,99	25	116	30	56	QTS100S-1900-DR01-ZYL25-MN	30572908
19,00	19,00 - 19,99	25	146	60	56	QTS100S-1900-DR03-ZYL25-MN	30572930
19,00	19,00 - 19,99	25	186	100	56	QTS100S-1900-DR05-ZYL25-MN	30572953
19,00	19,00 - 19,99	25	246	160	56	QTS100S-1900-DR08-ZYL25-MN	30572976
20,00	20,00 - 20,99	25	151	63	56	QTS100S-2000-DR03-ZYL25-MN	30572931
20,00	20,00 - 20,99	25	192	105	56	QTS100S-2000-DR05-ZYL25-MN	30572954
20,00	20,00 - 20,99	25	255	168	56	QTS100S-2000-DR08-ZYL25-MN	30572977
20,00	20,00 - 20,99	25	297	210	56	QTS100S-2000-DR10-ZYL25-MN	30826059
20,00	20,00 - 20,99	25	339	252	56	QTS100S-2000-DR12-ZYL25-MN	30598737
21,00	21,00 - 21,99	25	121	33	56	QTS100S-2100-DR01-ZYL25-MN	30572910
21,00	21,00 - 21,99	25	155	66	56	QTS100S-2100-DR03-ZYL25-MN	30572932
21,00	21,00 - 21,99	25	198	110	56	QTS100S-2100-DR05-ZYL25-MN	30572955
21,00	21,00 - 21,99	25	264	176	56	QTS100S-2100-DR08-ZYL25-MN	30572978
21,00	21,00 - 21,99	25	308	220	56	QTS100S-2100-DR10-ZYL25-MN	30826060
22,00	22,00 - 22,99	25	125	35	56	QTS100S-2200-DR01-ZYL25-MN	30572911
22,00	22,00 - 22,99	25	159	69	56	QTS100S-2200-DR03-ZYL25-MN	30572933
22,00	22,00 - 22,99	25	205	115	56	QTS100S-2200-DR05-ZYL25-MN	30572956
22,00	22,00 - 22,99	25	274	184	56	QTS100S-2200-DR08-ZYL25-MN	30572979
23,00	23,00 - 23,99	25	127	36	56	QTS100S-2300-DR01-ZYL25-MN	30572912
23,00	23,00 - 23,99	25	211	120	56	QTS100S-2300-DR05-ZYL25-MN	30572957
23,00	23,00 - 23,99	25	379	288	56	QTS100S-2300-DR12-ZYL25-MN	30598740
24,00	24,00 - 24,99	32	171	75	60	QTS100S-2400-DR03-ZYL32-MN	30572935
24,00	24,00 - 24,99	32	221	125	60	QTS100S-2400-DR05-ZYL32-MN	30572958
24,00	24,00 - 24,99	32	296	200	60	QTS100S-2400-DR08-ZYL32-MN	30572981
24,00	24,00 - 24,99	32	396	300	60	QTS100S-2400-DR12-ZYL32-MN	30598741
25,00	25,00 - 25,99	32	136	39	60	QTS100S-2500-DR01-ZYL32-MN	30572914
25,00	25,00 - 25,99	32	176	78	60	QTS100S-2500-DR03-ZYL32-MN	30572937
25,00	25,00 - 25,99	32	227	130	60	QTS100S-2500-DR05-ZYL32-MN	30572959
25,00	25,00 - 25,99	32	305	208	60	QTS100S-2500-DR08-ZYL32-MN	30572982
25,00	25,00 - 25,99	32	409	312	60	QTS100S-2500-DR12-ZYL32-MN	30598742
26,00	26,00 - 26,99	32	139	41	60	QTS100S-2600-DR01-ZYL32-MN	30572915
26,00	26,00 - 26,99	32	180	41	60	QTS100S-2600-DR03-ZYL32-MN	30572938
26,00	26,00 - 26,99	32	233	81	60	QTS100S-2600-DR05-ZYL32-MN	30572960
26,00	26,00 - 26,99	32	314	216	60	QTS100S-2600-DR08-ZYL32-MN	30572983
26,00	26,00 - 26,99	32	368	270	60	QTS100S-2600-DR10-ZYL32-MN	30826065
27,00	27,00 - 27,99	32	184	84	60	QTS100S-2700-DR03-ZYL32-MN	30572939
27,00	27,00 - 27,99	32	324	224	60	QTS100S-2700-DR08-ZYL32-MN	30572984
28,00	28,00 - 28,99	32	188	87	60	QTS100S-2800-DR03-ZYL32-MN	30572940
28,00	28,00 - 28,99	32	246	145	60	QTS100S-2800-DR05-ZYL32-MN	30572962
28,00	28,00 - 28,99	32	449	348	60	QTS100S-2800-DR12-ZYL32-MN	30598745
29,00	29,00 - 29,99	32	402	300	60	QTS100S-2900-DR10-ZYL32-MN	30826068
30,00	30,00 - 30,99	32	197	93	60	QTS100S-3000-DR03-ZYL32-MN	30572942
30,00	30,00 - 30,99	32	351	248	60	QTS100S-3000-DR08-ZYL32-MN	30572987
30,00	30,00 - 30,99	32	413	310	60	QTS100S-3000-DR10-ZYL32-MN	30826069

Continued on next page.

QTS indexable insert holder | QTS100, internal coolant supply

Dimensions						Specification	Order no.
Tool holder size D	Diameter range Indexable insert d ₁	d ₂ h6	l ₁	l ₃	l ₄		
30,00	30,00 - 30,99	32	475	372	60	QTS100S-3000-DR12-ZYL32-MN	30598747
31,00	31,00 - 31,99	32	264	160	60	QTS100S-3100-DR05-ZYL32-MN	30572965
32,00	32,00 - 32,99	32	271	165	60	QTS100S-3200-DR05-ZYL32-MN	30572966
32,00	32,00 - 32,99	32	436	330	60	QTS100S-3200-DR10-ZYL32-MN	30826071
32,00	32,00 - 32,99	32	502	396	60	QTS100S-3200-DR12-ZYL32-MN	30598749
33,00	33,00 - 33,99	32	209	102	60	QTS100S-3300-DR03-ZYL32-MN	30639167
34,00	34,00 - 34,99	32	283	175	60	QTS100S-3400-DR05-ZYL32-MN	30639172
35,00	35,00 - 35,99	32	218	108	60	QTS100S-3500-DR03-ZYL32-MN	30639169
36,00	36,00 - 36,99	32	222	111	60	QTS100S-3600-DR03-ZYL32-MN	30639170
37,00	37,00 - 38,99	40	318	195	70	QTS100S-3700-DR05-ZYL40-MN	30650288
39,00	39,00 - 40,99	40	249	123	70	QTS100S-3900-DR03-ZYL40-MN	30650284
41,00	41,00 - 42,99	40	257	129	70	QTS100S-4100-DR03-ZYL40-MN	30650285

Configurable features

Length design:
DR01 | DR03 | DR05 | DR08 |
DR10 | DR12

Specification:
QTS100S-3500-[Length design]-ZYL32-MN

Example:
QTS100S-3500-DR10-ZYL32-MN

Length design 10xD

Dimensions of configurable series

Tool holder size D	Diameter range of indexable insert d ₁	d ₂ h6	l ₄	DR01		DR03		DR05		DR08		DR10		DR12		Specification
				l ₁	l ₃	l ₁	l ₃	l ₁	l ₃	l ₁	l ₃	l ₁	l ₃	l ₁	l ₃	
9	9.00 - 9.49	12	45	77	15	92	29	110	48	138	76	-	-	-	-	QTS100S-0900-[Length design]-ZYL12-MN
9.5	9.50 - 9.99	12	45	78	15	93	30	113	50	143	80	-	-	-	-	QTS100S-0950-[Length design]-ZYL12-MN
10	10.00 - 10.49	16	48	83	16	99	32	120	53	151	84	-	-	-	-	QTS100S-1000-[Length design]-ZYL16-MN
10.5	10.50 - 10.99	16	48	84	17	101	33	122	55	155	88	-	-	-	-	QTS100S-1050-[Length design]-ZYL16-MN
11	11.00 - 11.49	16	48	86	18	103	35	126	58	160	92	-	-	-	-	QTS100S-1100-[Length design]-ZYL16-MN
11.5	11.50 - 11.99	16	48	86	18	105	36	128	60	164	96	-	-	-	-	QTS100S-1150-[Length design]-ZYL16-MN
12	12.00 - 12.49	16	48	88	19	107	38	132	63	169	100	-	-	-	-	QTS100S-1200-[Length design]-ZYL16-MN
12.5	12.50 - 12.99	16	48	90	20	109	39	135	65	174	104	-	-	-	-	QTS100S-1250-[Length design]-ZYL16-MN
13	13.00 - 13.49	16	48	91	21	112	41	138	68	178	108	135	205	232	162	QTS100S-1300-[Length design]-ZYL16-MN
13.5	13.50 - 13.99	16	48	92	21	113	42	141	70	183	112	140	211	239	168	QTS100S-1350-[Length design]-ZYL16-MN
14	14.00 - 14.49	16	48	93	22	116	44	144	73	187	116	145	216	245	174	QTS100S-1400-[Length design]-ZYL16-MN
14.5	14.50 - 14.99	16	48	95	23	117	45	147	75	192	120	150	222	252	180	QTS100S-1450-[Length design]-ZYL16-MN
15	15.00 - 15.99	20	50	99	24	124	48	155	80	203	128	162	237	267	192	QTS100S-1500-[Length design]-ZYL20-MN
16	16.00 - 16.99	20	50	102	26	128	51	161	85	212	136	170	246	280	204	QTS100S-1600-[Length design]-ZYL20-MN
17	17.00 - 17.99	20	50	105	27	132	54	168	90	222	144	180	258	294	216	QTS100S-1700-[Length design]-ZYL20-MN
18	18.00 - 18.99	25	56	114	29	142	57	180	95	237	152	190	275	313	228	QTS100S-1800-[Length design]-ZYL25-MN
19	19.00 - 19.99	25	56	116	30	146	60	186	100	246	160	200	286	326	240	QTS100S-1900-[Length design]-ZYL25-MN
20	20.00 - 20.99	25	56	119	32	151	63	192	105	255	168	210	297	339	252	QTS100S-2000-[Length design]-ZYL25-MN
21	21.00 - 21.99	25	56	121	33	155	66	198	110	264	176	220	308	352	264	QTS100S-2100-[Length design]-ZYL25-MN
22	22.00 - 22.99	25	56	125	35	159	69	205	115	274	184	230	320	366	276	QTS100S-2200-[Length design]-ZYL25-MN
23	23.00 - 23.99	25	56	127	36	163	72	211	120	283	192	240	331	379	288	QTS100S-2300-[Length design]-ZYL25-MN
24	24.00 - 24.99	32	60	134	38	171	75	221	125	296	200	250	346	396	300	QTS100S-2400-[Length design]-ZYL32-MN
25	25.00 - 25.99	32	60	136	39	176	78	227	130	305	208	260	357	409	312	QTS100S-2500-[Length design]-ZYL32-MN
26	26.00 - 26.99	32	60	139	41	180	81	233	135	314	216	270	368	422	324	QTS100S-2600-[Length design]-ZYL32-MN
27	27.00 - 27.99	32	60	142	42	184	84	240	140	324	224	280	380	436	336	QTS100S-2700-[Length design]-ZYL32-MN

Dimensions of configurable series

Tool holder size D	Diameter range of indexable insert d ₁	d ₂ h ₆	l ₄	DR01		DR03		DR05		DR08		DR10		DR12		Specification
				l ₁	l ₃	l ₁	l ₃	l ₁	l ₃	l ₁	l ₃	l ₁	l ₃	l ₁	l ₃	
28	28.00 - 28.99	32	60	145	44	188	87	246	145	333	232	290	391	449	348	QTS100S-2800-[Length design]-ZYL32-MN
29	29.00 - 29.99	32	60	147	45	192	90	252	150	342	240	300	402	462	360	QTS100S-2900-[Length design]-ZYL32-MN
30	30.00 - 30.99	32	60	150	47	197	93	258	155	351	248	310	413	475	372	QTS100S-3000-[Length design]-ZYL32-MN
31	31.00 - 31.99	32	60	152	48	201	96	264	160	360	256	320	424	488	384	QTS100S-3100-[Length design]-ZYL32-MN
32	32.00 - 32.99	32	60	156	50	205	99	271	165	370	264	330	436	502	396	QTS100S-3200-[Length design]-ZYL32-MN
33	33.00 - 33.99	32	60	158	51	209	102	277	170	379	272	340	447	515	408	QTS100S-3300-[Length design]-ZYL32-MN
34	34.00 - 34.99	32	60	161	53	213	105	283	175	388	280	350	458	528	420	QTS100S-3400-[Length design]-ZYL32-MN
35	35.00 - 35.99	32	60	163	54	218	108	289	180	397	288	360	469	541	432	QTS100S-3500-[Length design]-ZYL32-MN
36	36.00 - 36.99	32	60	166	56	222	111	295	185	406	296	370	480	554	444	QTS100S-3600-[Length design]-ZYL32-MN
37	37.00 - 38.99	40	70	182	59	240	117	318	195	435	312	390	515	591	468	QTS100S-3700-[Length design]-ZYL40-MN
39	39.00 - 40.99	40	70	187	62	249	123	330	205	453	328	410	537	617	492	QTS100S-3900-[Length design]-ZYL40-MN
41	41.00 - 42.99	40	70	193	65	257	129	343	215	472	344	430	560	644	516	QTS100S-4100-[Length design]-ZYL40-MN
43	43.00 - 44.99	40	70	198	68	265	135	355	225	490	360	440	582	670	540	QTS100S-4300-[Length design]-ZYL40-MN
45	45.00 - 46.99	40	70	203	71	274	141	367	235	508	376	470	604	696	564	QTS100S-4500-[Length design]-ZYL40-MN
47	47.00 - 48.99	40	70	211	74	284	147	382	245	529	392	490	627	725	588	QTS100S-4700-[Length design]-ZYL40-MN
49	49.00 - 50.99	40	70	216	77	293	153	394	255	547	408	510	649	751	612	QTS100S-4900-[Length design]-ZYL40-MN

Dimensions in mm.

Special designs available upon request.



COUNTERSINKS WITH EXTREMELY UNEQUAL SPACING

Finally, it can be quiet, fast and accurate

Every machining process has latent potential for boosting productivity. There is significant potential for improvement even in machining operations that seem secondary. This is proven by the countersinks from MAPAL.

The countersinks operate with significantly reduced axial forces. Their cutting edges are unequally spaced. With the selected spacing, the axial force is reduced by more than 50 per cent and the radial force by 25 per cent, compared to conventional countersinks. The optimised operating conditions create significantly less vibration in the tool, allowing more accuracy and better surface finishes.

The level of precision now achieved by the countersinks directly improves the contact of the bolted and riveted joints, so the joints no longer settle under load after assembly. The reduced load on the machine also increases the tool life. As the tool runs smooth and stable, it can also be operated with higher cutting data. This results in significant time savings.



Tool features in detail

Radial force reduced by 25%

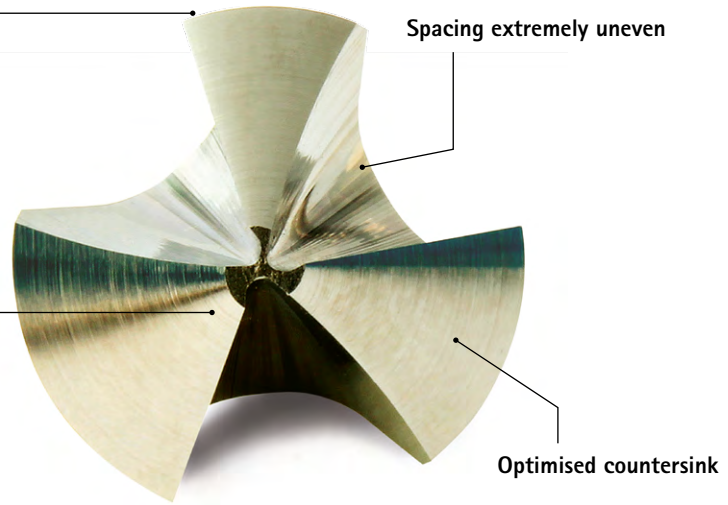
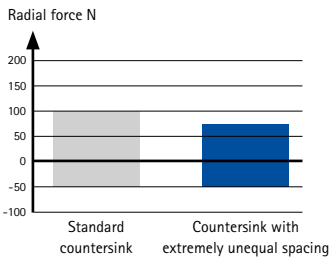

Axial force reduced by 50%

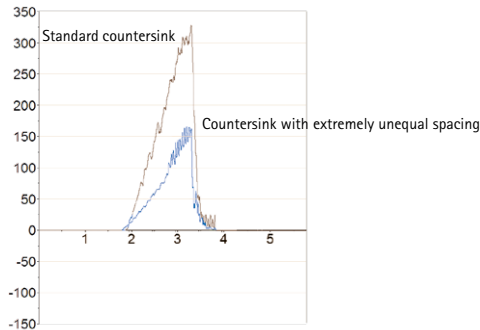

Countersink with extremely unequal spacing



Standard countersink

HSS design, coated



For all common workpiece materials (such as steel, stainless steel or aluminium), the countersinks in HSS design with high-performance coating are the tool of choice. The coating ensures a long tool life. The tools work safely and reliably, even at high cutting speeds. For more demanding workpiece materials, the solid carbide design is recommended.

Solid carbide design, coated



In addition to the high-performance-coated HSS designs of countersinks, MAPAL also offers selected diameters in a coated solid carbide version. Along with the advantages of unequal spacing, the solid carbide design offers additional added value during the machining of demanding workpiece materials, such as titanium, high-alloy cast iron, Inconel or CFRP. Longer tool lives and higher cutting speeds are reliably achieved, compared with the coated HSS design.

Special drill designs with countersink step



MAPAL offers the possibility of manufacturing a countersink step for almost all solid carbide drills as a special solution. In this way, both machining operations, drilling and countersinking, can be carried out using a single tool, which reduces downtimes. At MAPAL, the most up-to-date manufacturing technologies as well as flexible manufacturing make short delivery times for custom solutions possible worldwide.

90° countersink

HSS design, coated, extremely unequal spacing
COS110

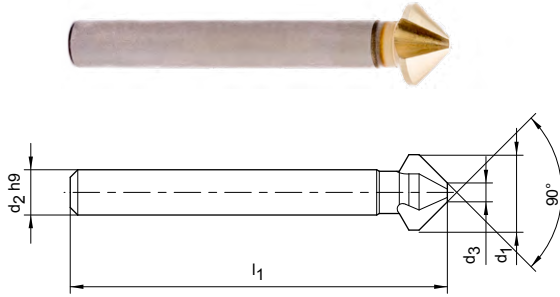

Dimensions					Specification	Order no.
d ₁	d ₂	d ₃	l ₁	z		
4.30	4	1.3	40	3	COS110-0430-335C-SP345	30662991
6.00	5	1.5	45	3	COS110-0600-335C-SP345	30662992
6.30	5	1.5	45	3	COS110-0630-335C-SP345	30633783
8.00	6	2.0	50	3	COS110-0800-335C-SP345	30662993
8.30	6	2.0	50	3	COS110-0830-335C-SP345	30662994
10.00	6	2.5	50	3	COS110-1000-335C-SP345	30662996
10.40	6	2.5	50	3	COS110-1040-335C-SP345	30633784
11.50	8	2.8	56	3	COS110-1150-335C-SP345	30662997
12.40	8	2.8	56	3	COS110-1240-335C-SP345	30662998
15.00	10	3.2	60	3	COS110-1500-335C-SP345	30662999
16.50	10	3.2	60	3	COS110-1650-335C-SP345	30633786
19.00	10	3.5	63	3	COS110-1900-335C-SP345	30663000
20.50	10	3.5	63	3	COS110-2050-335C-SP345	30633787
23.00	10	3.8	67	3	COS110-2300-335C-SP345	30663001
25.00	10	3.8	67	3	COS110-2500-335C-SP345	30633788
31.00	12	4.2	71	3	COS110-3100-335C-SP345	30663003



Countersink set

d ₁	Specification	Order no.
6,30 - 25,00	COS110-6.3-25-335C-SP345-SET Set consists of ø 6.30 mm ø 10.4 mm ø 16.5 mm ø 20.5 mm ø 25.0 mm	30634356

Dimensions in mm.

For cutting data recommendations, see end of chapter.

90° countersink

Solid carbide design, coated, extremely unequal spacing
COS110

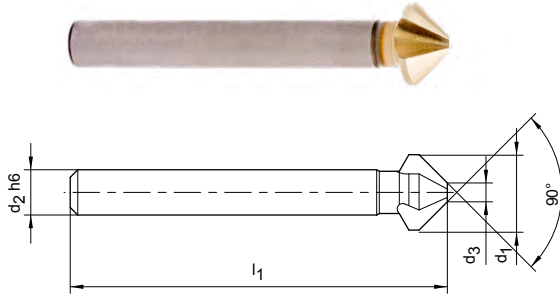

Dimensions					Specification	Order no.
d ₁	d ₂	d ₃	l ₁	z		
6.30	5	1.5	45	3	COS110-0630-335C-HP437	30799189
8.30	6	2.0	50	3	COS110-0830-335C-HP437	30799191
10.40	6	2.5	50	3	COS110-1040-335C-HP437	30799192
12.40	8	2.8	56	3	COS110-1240-335C-HP437	30799195
16.50	10	3.2	60	3	COS110-1650-335C-HP437	30799198
20.50	10	3.5	63	3	COS110-2050-335C-HP437	30799199
25.00	10	3.8	67	3	COS110-2500-335C-HP437	30799201
31.00	12	4.2	71	3	COS110-3100-335C-HP437	30799203

Dimensions in mm.

For cutting data recommendations, see end of chapter.

Spare parts

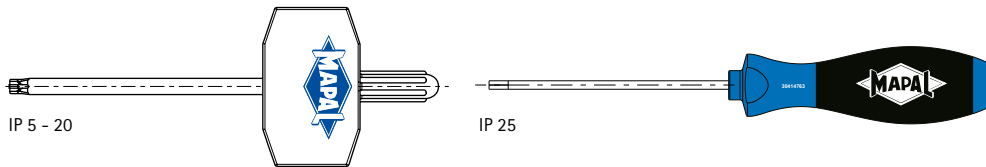

Screwdriver

Torx size TORX PLUS®	Order no.
5 IP	30584281
6 IP	30584282
7 IP	30584283
8 IP	30584284
9 IP	30584285
10 IP	30584286
15 IP	30584287
20 IP	30584288
25 IP	30414767

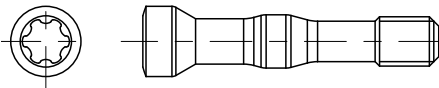

Clamping screw

ø area	TORX PLUS® size	Order no.	Specification	Tightening torque [Nm]
8,00 - 8,99	5 IP	30604440	M1.2X7.5-TX5-IP	0,2
9,00 - 10,99	5 IP	30546309	M1.2X8.5-TX5-IP	0,2
11,00 - 12,99	6 IP	30604180	M1.6X10.5-TX6-IP	0,4
13,00 - 13,99	7 IP	30510826	M2x12-TX7-IP	0,6
14,00 - 15,99	8 IP	30510827	M2.2x13-TX8-IP	0,9
16,00 - 18,99	8 IP	30495432	M2.5x15-TX8-IP	1,2
19,00 - 21,99	9 IP	30510829	M3x18-TX9-IP	2,2
22,00 - 24,99	10 IP	30510830	M3.5x21-TX10-IP	3,3
25,00 - 27,99	15 IP	30510831	M4x24-TX15-IP	5,0
28,00 - 30,99	15 IP	30510832	M4.5x27-TX15-IP	5,7
31,00 - 32,99	20 IP	30510833	M5x30-TX20-IP	7,5
33,00 - 36,99	20 IP	30651830	M5X32-TX20-IP	7,5
37,00 - 44,99	25 IP	30651399	M6X35-TX25-IP	15,0
45,00 - 50,99	25 IP	30651510	M6X43-TX25-IP	15,0

Instructions for using the QTD indexable insert drill

Easily change and set the QTD cutting edge

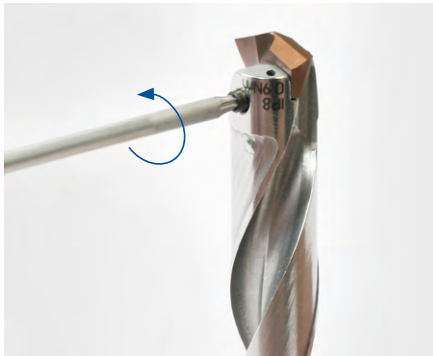

1. Undo the special clamping screw using the supplied TORX® PLUS wrench by turning it anticlockwise.



2. Remove the indexable insert from the insert seat.



3. Clean the insert seat using compressed air.

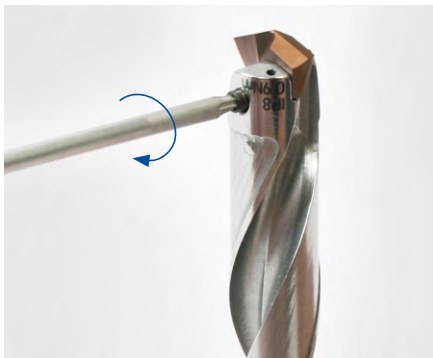

4. Fit the new indexable insert in the insert seat. Hand tighten the special clamping screw using the supplied TORX® PLUS wrench by turning it clockwise.



5. Tighten the special clamping screw to the specified tightening torque.

Note:

- Use original screws only!
- The special clamping screw must be replaced during the 5th drill head change at the latest.
- The applicable tightening torque is engraved on the tool itself.

Result:

The indexable insert has now been successfully changed and the tool can be used.



Deep drilling in three steps

1 Making a pilot bore

MEGA-Drill-Steel-Plus [SCD600, SCD601]

For general drilling conditions



MEGA-Step-Drill-Steel-Plus [SCD590, SCD591]

For general drilling conditions incl. 90° countersink



MEGA-Speed-Drill-Steel [SCD621]

For general drilling conditions



Info:

Select nominal \emptyset that is 0.02 mm larger.

Example:

Pilot tool; MEGA-Speed-Drill-Steel,
nominal \emptyset 5.02 mm

Subsequent tool: MEGA-Deep-Drill-Steel,
nominal \emptyset 5.00 mm

MEGA-180°-Drill [SCD231]

For difficult drilling conditions



2 Deep drilling up to 30xD

Entry into the pilot bore:

- Commissioning at max. 300 rpm and $v_f = 1,000$ mm/min
- Without coolant – up to 1 mm before the bottom of the bore of the pilot bore
- Switch on coolant
→ cooling lubricant = 10–40 bar/MQL
- Spot drilling with specified cutting data according to table

Info:

Further method for spot drilling with MEGA-Deep-Drill-Steel: Spot drilling with 50% feed, linear acceleration to 100% feed up to drilling depth of 4xD

- **Deep drilling up to 30xD in one process, without chip removal cycles**

Running out:

- Run out at max. 300 rpm and double the feed ($2x v_f$)
- Switch off coolant

3 Deep drilling up to 40xD

Entry into the 30xD bore:

- Commissioning at max. 300 rpm and $v_f = 1,000$ mm/min
- Without coolant – up to 1 mm before the bottom of the bore of the 30xD bore
- Switch on coolant
→ cooling lubricant = 10–40 bar/MQL
- Spot drilling with specified cutting data according to table

Info:

Further method for spot drilling with MEGA-Deep-Drill-Steel: Spot drilling with 50% feed, linear acceleration to 100% feed up to drilling depth of 32xD

- **Deep drilling up to 40xD in one go, without chip removal cycles**

Running out:

- Run out at max. 300 rpm and double the feed ($2x v_f$)
- Switch off coolant

Selecting the suitable pilot drill

- The nominal diameter of the pilot drill must match the nominal diameter of the MEGA-Deep-Drill-Steel.
- The point angle and diameter tolerances are matched for optimal functionality as well as for the interaction of pilot drill and deep drill.

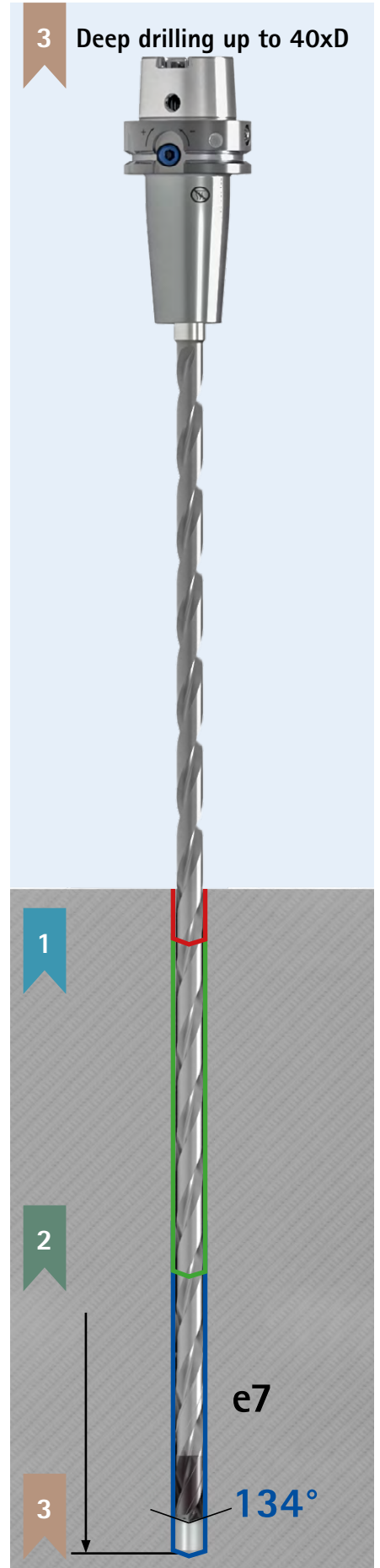
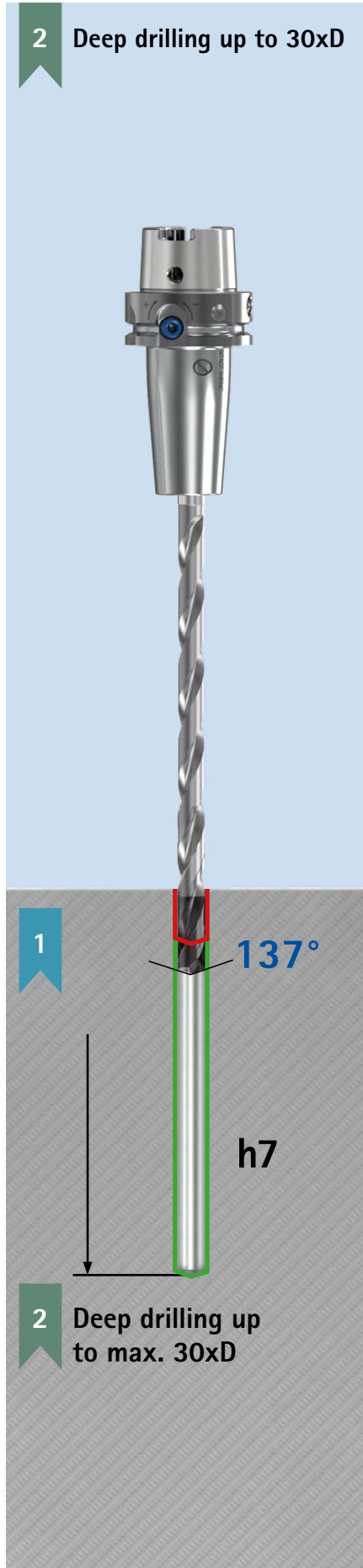
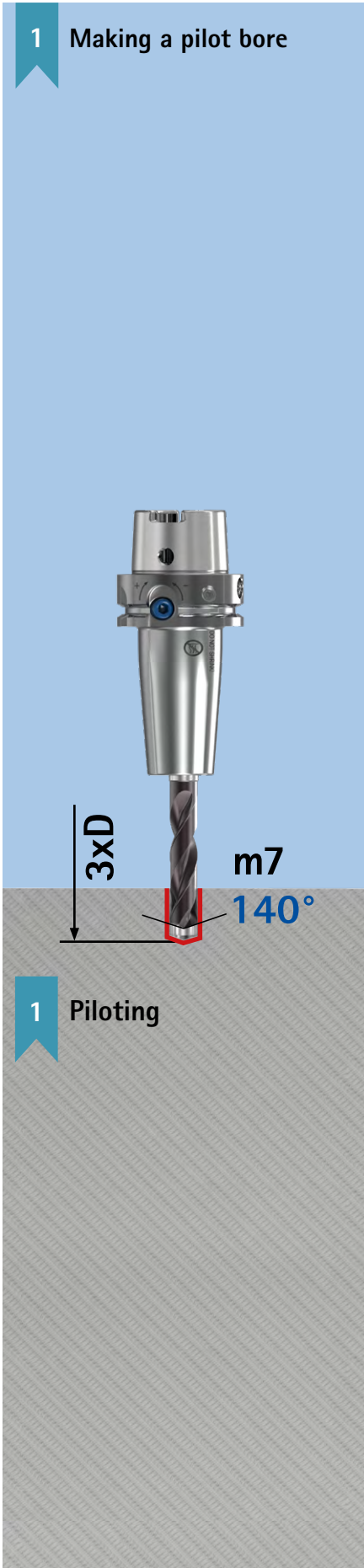

Cutting data recommendations for solid carbide drills

Feed and cutting speed

MICRO-Drill-Steel | SCD371

MMG*		Workpiece material	Strength/hardness [N/mm ²] [HRC]
P	P1	P1.1 Structural, machining, case hardened and tempering steels, unalloyed	< 700
		P1.2 Structural, machining, case hardened and tempering steels, unalloyed	< 1,200
	P2	P2.1 Nitriding, hardening and tempering steels, alloyed	< 900
		P2.2 Nitriding, hardening and tempering steels, alloyed	< 1,400
	P3	P3.1 Tool, bearing, spring and high-speed steels**	< 800
		P3.2 Tool, bearing, spring and high-speed steels**	< 1,000
		P3.3 Tool, bearing, spring and high-speed steels**	< 1,500
	P5	P5.1 Cast steel	
M	M1	M1.1 Stainless steels, austenitic	< 700
		M1.2 Stainless steels, ferritic/austenitic (duplex)	< 1,000
K	K1	K1.1 Cast iron with lamellar graphite (grey cast iron), GJL	< 300
		K2.1 Cast iron with spheroidal graphite, GJS	< 500
	K2	K2.2 Cast iron with spheroidal graphite, GJS	≤ 800
		K2.3 Cast iron with spheroidal graphite, GJS	> 800
	K3	K3.1 Cast iron with vermicular graphite, GJV; malleable cast iron, GJM	< 500
		K3.2 Cast iron with vermicular graphite, GJV; malleable cast iron, GJM	> 500

ECU-Drill-Steel | SCD361

MMG*		Workpiece material	Strength/hardness [N/mm ²] [HRC]
P	P1	P1.1 Structural, machining, case hardened and tempering steels, unalloyed	< 700
		P1.2 Structural, machining, case hardened and tempering steels, unalloyed	< 1,200
	P2	P2.1 Nitriding, hardening and tempering steels, alloyed	< 900
		P2.2 Nitriding, hardening and tempering steels, alloyed	< 1,400
	P3	P3.1 Tool, bearing, spring and high-speed steels**	< 800
		P3.2 Tool, bearing, spring and high-speed steels**	< 1,000
		P3.3 Tool, bearing, spring and high-speed steels**	< 1,500
	P5	P5.1 Cast steel	
P6	P6.1 Stainless cast steels, ferritic and martensitic		
K	K1	K1.1 Cast iron with lamellar graphite (grey cast iron), GJL	< 300
		K2.1 Cast iron with spheroidal graphite, GJS	< 500
	K2	K2.2 Cast iron with spheroidal graphite, GJS	≤ 800
		K2.3 Cast iron with spheroidal graphite, GJS	> 800
	K3	K3.1 Cast iron with vermicular graphite, GJV; malleable cast iron, GJM	< 500
		K3.2 Cast iron with vermicular graphite, GJV; malleable cast iron, GJM	> 500

* MAPAL Machining Groups

** If the alloy parts Cr, Mo, Ni, V, W in total > 8%, then select the next highest MAPAL machining group.

	Cutting speed v_c [m/min]				Feed f [mm] for drill diameter					
	Internal cooling	External cooling	MQL	Air	4.00	5.50	7.50	10.50	14.50	20.00
	80	70	70		0.04	0.04	0.05	0.06	0.07	0.08
	70	60	60		0.04	0.05	0.06	0.07	0.08	0.10
	80	70	70		0.04	0.05	0.06	0.07	0.08	0.09
	55	50	50		0.04	0.05	0.05	0.06	0.07	0.08
	60	50	50		0.04	0.04	0.05	0.06	0.07	0.08
	50	45	45		0.04	0.04	0.04	0.05	0.06	0.07
	50	35	40		0.03	0.04	0.04	0.05	0.05	0.06
	80	70	70		0.04	0.05	0.06	0.07	0.08	0.09
	40	25	25		0.03	0.03	0.03	0.04	0.05	0.06
	95	70	70	70	0.03	0.04	0.05	0.06	0.08	0.11
	130	80	95	95	0.04	0.05	0.06	0.07	0.09	0.11
	80	60	60		0.04	0.05	0.05	0.07	0.08	0.10
	70	65	65		0.04	0.05	0.06	0.07	0.09	0.11
	65	55	55		0.04	0.05	0.06	0.07	0.08	0.09

	Cutting speed v_c [m/min]				Feed f [mm] for drill diameter					
	Internal cooling	External cooling	MQL	Air	1.00	1.80	3.30	6.00	11.00	20.00
	75	70	70		0.05	0.06	0.09	0.13	0.19	0.27
	70	55	55		0.06	0.08	0.11	0.16	0.24	0.34
	75	65	65		0.06	0.07	0.10	0.15	0.23	0.32
	55	45	45		0.05	0.07	0.09	0.12	0.18	0.25
	55	50	50		0.05	0.07	0.09	0.14	0.20	0.29
	45	40	40		0.05	0.06	0.08	0.11	0.17	0.23
	45	35	40		0.04	0.05	0.07	0.09	0.13	0.18
	75	65	65		0.06	0.07	0.10	0.15	0.23	0.32
	45	35	40		0.03	0.04	0.06	0.09	0.13	0.19
	80	60	60	60	0.05	0.08	0.12	0.19	0.31	0.45
	110	70	80	80	0.06	0.08	0.12	0.19	0.29	0.41
	70	50	50		0.06	0.08	0.11	0.16	0.25	0.36
	60	55	55		0.06	0.08	0.12	0.18	0.27	0.38
	55	50	50		0.06	0.07	0.10	0.15	0.22	0.30

The specified cutting data are guide values.

The optimum data for the respective machining task should be determined during the test or machining.

Cutting data recommendations for solid carbide drills

Feed and cutting speed

MEGA-Drill-Steel-Plus | SCD600, 601

MMG*	Workpiece material		Strength/hardness [N/mm ²] [HRC]
P	P1	P1.1 Structural, machining, case hardened and tempering steels, unalloyed	< 700
		P1.2 Structural, machining, case hardened and tempering steels, unalloyed	< 1,200
	P2	P2.1 Nitriding, hardening and tempering steels, alloyed	< 900
		P2.2 Nitriding, hardening and tempering steels, alloyed	< 1,400
	P3	P3.1 Tool, bearing, spring and high-speed steels**	< 800
		P3.2 Tool, bearing, spring and high-speed steels**	< 1,000
		P3.3 Tool, bearing, spring and high-speed steels**	< 1,500
	P4	P4.1 Stainless steels, ferritic and martensitic	
	P5	P5.1 Cast steel	
	P6	P6.1 Stainless cast steels, ferritic and martensitic	
K	K1	K1.1 Cast iron with lamellar graphite (grey cast iron), GJL	< 300
		K2.1 Cast iron with spheroidal graphite, GJS	< 500
	K2	K2.2 Cast iron with spheroidal graphite, GJS	≤ 800
		K2.3 Cast iron with spheroidal graphite, GJS	> 800
	K3	K3.1 Cast iron with vermicular graphite, GJV; malleable cast iron, GJM	< 500
		K3.2 Cast iron with vermicular graphite, GJV; malleable cast iron, GJM	> 500
H	H1	H1.1 Hardened steel / cast steel	< 44 HRC
		H1.2 Hardened steel / cast steel	< 55 HRC

MEGA-Drill-Hardened | SCD140

MMG*	Workpiece material		Strength/hardness [N/mm ²] [HRC]
H	H1	H1.1 Hardened steel / cast steel	< 44 HRC
		H1.2 Hardened steel / cast steel	< 55 HRC
	H2	H2.1 Hardened steel / cast steel	< 60 HRC
		H2.2 Hardened steel / cast steel	< 65 HRC
		H2.3 Hardened steel / cast steel	< 68 HRC

* MAPAL Machining Groups

** If the alloy parts Cr, Mo, Ni, V, W in total > 8%, then select the next highest MAPAL machining group.

	Cutting speed v_c [m/min]				Feed f [mm] for drill diameter					
	Internal cooling	External cooling	MQL	Air	3.00	4.50	6.50	9.50	14.00	20.00
	110	100	100		0.10	0.13	0.16	0.21	0.27	0.33
	100	85	85		0.13	0.16	0.21	0.27	0.34	0.41
	110	95	95		0.12	0.15	0.19	0.25	0.32	0.39
	75	65	65		0.10	0.13	0.16	0.20	0.26	0.31
	85	70	70		0.11	0.14	0.17	0.23	0.29	0.35
	65	60	60		0.09	0.12	0.15	0.19	0.24	0.29
	65	50	55		0.08	0.09	0.12	0.15	0.18	0.22
	65	50	55		0.07	0.09	0.12	0.15	0.19	0.23
	110	95	95		0.12	0.15	0.19	0.25	0.32	0.39
	65	50	55		0.07	0.09	0.12	0.15	0.19	0.23
	120	85	85	85	0.14	0.19	0.25	0.34	0.45	0.55
	160	100	120	120	0.14	0.18	0.24	0.32	0.41	0.51
	100	75	75		0.12	0.16	0.21	0.28	0.36	0.43
	90	80	80		0.13	0.18	0.23	0.30	0.38	0.47
	80	70	70		0.12	0.15	0.19	0.24	0.31	0.37
	90	90	90		0.09	0.12	0.15	0.19	0.24	0.29
	25	25	25		0.05	0.06	0.08	0.10	0.13	0.16

	Cutting speed v_c [m/min]				Feed f [mm] for drill diameter [mm]					
	Internal cooling	External cooling	MQL	Air	2.50	3.60	5.30	7.60	11.00	16.00
	30	30	30		0.05	0.06	0.08	0.10	0.13	0.16
		30	30		0.04	0.05	0.06	0.08	0.11	0.13
		20	20		0.03	0.04	0.05	0.06	0.07	0.09

The specified cutting data are guide values.

The optimum data for the respective machining task should be determined during the test or machining.

Cutting data recommendations for solid carbide drills

Feed and cutting speed

Tritan-Drill-Steel | SCD661

MMG*		Workpiece material	Strength/hardness [N/mm ²] [HRC]
P	P1	P1.1 Structural, machining, case hardened and tempering steels, unalloyed	< 700
		P1.2 Structural, machining, case hardened and tempering steels, unalloyed	< 1,200
	P2	P2.1 Nitriding, hardening and tempering steels, alloyed	< 900
		P2.2 Nitriding, hardening and tempering steels, alloyed	< 1,400
	P3	P3.1 Tool, bearing, spring and high-speed steels**	< 800
		P3.2 Tool, bearing, spring and high-speed steels**	< 1,000
		P3.3 Tool, bearing, spring and high-speed steels**	< 1,500
	P5	P5.1 Cast steel	
M	M1	M1.1 Stainless steels, austenitic	< 700
		M1.2 Stainless steels, ferritic/austenitic (duplex)	< 1,000
K	K1	K1.1 Cast iron with lamellar graphite (grey cast iron), GJL	< 300
		K2.1 Cast iron with spheroidal graphite, GJS	< 500
	K2	K2.2 Cast iron with spheroidal graphite, GJS	≤ 800
		K2.3 Cast iron with spheroidal graphite, GJS	> 800
	K3	K3.1 Cast iron with vermicular graphite, GJV; malleable cast iron, GJM	< 500
		K3.2 Cast iron with vermicular graphite, GJV; malleable cast iron, GJM	> 500

MEGA-180°-Drill | SCD231

MMG*		Workpiece material	Strength/hardness [N/mm ²] [HRC]
P	P1	P1.1 Structural, machining, case hardened and tempering steels, unalloyed	< 700
		P1.2 Structural, machining, case hardened and tempering steels, unalloyed	< 1,200
	P2	P2.1 Nitriding, hardening and tempering steels, alloyed	< 900
		P2.2 Nitriding, hardening and tempering steels, alloyed	< 1,400
	P3	P3.1 Tool, bearing, spring and high-speed steels**	< 800
		P3.2 Tool, bearing, spring and high-speed steels**	< 1,000
		P3.3 Tool, bearing, spring and high-speed steels**	< 1,500
	P5	P5.1 Cast steel	
K	K1	K1.1 Cast iron with lamellar graphite (grey cast iron), GJL	< 300
		K2.1 Cast iron with spheroidal graphite, GJS	< 500
	K2	K2.2 Cast iron with spheroidal graphite, GJS	≤ 800
		K2.3 Cast iron with spheroidal graphite, GJS	> 800
	K3	K3.1 Cast iron with vermicular graphite, GJV; malleable cast iron, GJM	< 500
		K3.2 Cast iron with vermicular graphite, GJV; malleable cast iron, GJM	> 500

* MAPAL Machining Groups

** If the alloy parts Cr, Mo, Ni, V, W in total > 8%, then select the next highest MAPAL machining group.

	Cutting speed v_c [m/min]				Feed f [mm] for drill diameter					
	Internal cooling	External cooling	MQL	Air	4.00	5.50	7.50	10.50	14.50	20.00
	115	105	105		0.24	0.30	0.37	0.46	0.56	0.65
	105	85	85		0.30	0.37	0.46	0.58	0.70	0.81
	115	100	100		0.28	0.35	0.44	0.55	0.66	0.77
	80	70	70		0.24	0.29	0.36	0.44	0.53	0.61
	85	75	75		0.25	0.31	0.39	0.49	0.60	0.69
	70	65	65		0.21	0.26	0.33	0.41	0.49	0.56
	70	50	60		0.18	0.21	0.26	0.32	0.38	0.43
	115	100	100		0.28	0.35	0.44	0.55	0.66	0.77
	55	35	35		0.11	0.14	0.18	0.22	0.27	0.31
	140	100	100	100	0.34	0.45	0.58	0.75	0.92	1.08
	185	115	140	140	0.34	0.43	0.55	0.70	0.85	1.00
	115	85	85		0.30	0.38	0.48	0.61	0.74	0.86
	70	45	60		0.16	0.20	0.25	0.31	0.38	0.44
	105	90	90		0.32	0.41	0.52	0.65	0.79	0.92
	90	80	80		0.27	0.34	0.42	0.52	0.63	0.73

	Cutting speed v_c [m/min]				Feed f [mm] for drill diameter					
	Internal cooling	External cooling	MQL	Air	3.00	4.50	6.50	9.50	14.00	20.00
	80	70	70		0.07	0.09	0.12	0.16	0.20	0.24
	70	60	60		0.09	0.12	0.15	0.20	0.25	0.30
	80	70	70		0.08	0.11	0.14	0.19	0.24	0.28
	55	50	50		0.07	0.09	0.12	0.15	0.19	0.22
	60	50	50		0.07	0.10	0.13	0.17	0.21	0.25
	50	45	45		0.06	0.08	0.11	0.14	0.17	0.21
	50	35	40		0.05	0.07	0.09	0.11	0.14	0.16
	80	70	70		0.08	0.11	0.14	0.19	0.24	0.28
	95	70	70	70	0.09	0.14	0.19	0.25	0.33	0.39
	130	80	95	95	0.10	0.13	0.18	0.24	0.30	0.36
	80	60	60		0.09	0.12	0.16	0.21	0.26	0.31
	50	30	40		0.06	0.08	0.11	0.14	0.17	0.21
	70	65	65		0.09	0.13	0.17	0.22	0.28	0.33
	65	55	55		0.08	0.11	0.14	0.18	0.22	0.26

The specified cutting data are guide values.

The optimum data for the respective machining task should be determined during the test or machining.

Cutting data recommendations for pilot drills

Feed and cutting speed

Tritan-Spot-Drill-Steel | SCD670

MMG*		Workpiece material	Strength/hardness [N/mm ²] [HRC]
P	P1	P1.1 Structural, machining, case hardened and tempering steels, unalloyed	< 700
		P1.2 Structural, machining, case hardened and tempering steels, unalloyed	< 1,200
	P2	P2.1 Nitriding, hardening and tempering steels, alloyed	< 900
		P2.2 Nitriding, hardening and tempering steels, alloyed	< 1,400
	P3	P3.1 Tool, bearing, spring and high-speed steels**	< 800
		P3.2 Tool, bearing, spring and high-speed steels**	< 1,000
		P3.3 Tool, bearing, spring and high-speed steels**	< 1,500
P5	P5.1 Cast steel		
M	M1	M1.1 Stainless steels, austenitic	< 700
		M1.2 Stainless steels, ferritic/austenitic (duplex)	< 1,000
	M2	M2.1 Stainless cast steel, austenitic	< 700
	M3	M3.1 Stainless cast steel, ferritic/austenitic (duplex)	< 1,000
K	K1	K1.1 Cast iron with lamellar graphite (grey cast iron), GJL	< 300
		K2.1 Cast iron with spheroidal graphite, GJS	< 500
	K2	K2.2 Cast iron with spheroidal graphite, GJS	≤ 800
		K2.3 Cast iron with spheroidal graphite, GJS	> 800
	K3	K3.1 Cast iron with vermicular graphite, GJV; malleable cast iron, GJM	< 500
		K3.2 Cast iron with vermicular graphite, GJV; malleable cast iron, GJM	> 500
N	N1	N1.1 Aluminium, unalloyed and alloyed < 3% Si	
		N1.2 Aluminium, alloyed ≤ 7% Si	
		N1.3 Aluminium, alloyed > 7-12% Si	
		N1.4 Aluminium, alloyed > 12% Si	
	N2	N2.1 Copper, unalloyed and low alloyed	< 300
		N2.2 Copper, alloyed	> 300
		N2.3 Brass, bronze, gunmetal	< 1,200
	N4	N4.1 Plastic, thermoplastics	
		N4.2 Plastic, duroplastics	
		N4.3 Plastic, foam materials	
S	S1	S1.1 Titanium, titanium alloys	< 400
		S2.1 Titanium, titanium alloys	< 1,200
	S2	S2.2 Titanium, titanium alloys	> 1,200
		S3.1 Nickel, unalloyed and alloyed	< 900
	S3	S3.2 Nickel, unalloyed and alloyed	> 900
		S4.1 High-temperature super alloy, Ni-, Co-, and Fe-based	
	S5	S5.1 Molybdenum and tungsten alloys	
H	H1	H1.1 Hardened steel/cast steel	< 44
		H1.2 Hardened steel/cast steel	< 55

* MAPAL Machining Groups

** If the alloy parts Cr, Mo, Ni, V, W in total > 8%, then select the next highest MAPAL machining group.

	Cutting speed v_c [m/min]				Feed f [mm] for drill diameter					
	Internal cooling	External cooling	MQL	Air	4.00	5.50	7.50	10.50	14.50	20.00
	175	160	160		0.09	0.10	0.11	0.13	0.14	0.15
	160	130	130		0.11	0.12	0.14	0.16	0.17	0.18
	170	145	145		0.10	0.12	0.13	0.15	0.16	0.17
	120	100	100		0.08	0.09	0.11	0.12	0.13	0.14
	110	95	95		0.09	0.11	0.12	0.13	0.15	0.16
	90	85	85		0.08	0.09	0.10	0.11	0.12	0.13
	90	70	75		0.06	0.07	0.08	0.08	0.09	0.10
	110	95	95		0.10	0.12	0.13	0.15	0.16	0.17
	70	45	45		0.06	0.07	0.08	0.09	0.10	0.10
	75	50	50		0.06	0.07	0.08	0.09	0.10	0.10
	245	175	175	175	0.17	0.19	0.22	0.25	0.27	0.30
	225	140	170	170	0.16	0.18	0.20	0.23	0.25	0.27
	170	130	130		0.14	0.15	0.18	0.20	0.22	0.23
	100	70	85		0.09	0.10	0.12	0.13	0.14	0.15
	155	135	135		0.15	0.17	0.19	0.21	0.23	0.25
	135	120	120		0.12	0.13	0.15	0.17	0.19	0.20
	300	200	250		0.11	0.12	0.13	0.15	0.17	0.18
	250	180	200		0.14	0.15	0.18	0.20	0.22	0.23
	220	150	180		0.14	0.15	0.18	0.20	0.22	0.23
	180	120	150		0.14	0.15	0.18	0.20	0.22	0.23
	140	100			0.11	0.12	0.13	0.15	0.17	0.18
	120	90			0.14	0.15	0.18	0.20	0.22	0.23
	200	160	160	120	0.17	0.19	0.22	0.25	0.27	0.30
		60		50	0.09	0.10	0.12	0.13	0.14	0.15
		65		40	0.07	0.08	0.09	0.11	0.12	0.12
			400	0.07	0.08	0.09	0.11	0.12	0.12	
	40	25			0.062	0.069	0.078	0.088	0.097	0.104
	30	20			0.053	0.059	0.067	0.075	0.083	0.089
	25	15			0.044	0.050	0.056	0.063	0.069	0.074
	20	15			0.035	0.040	0.045	0.050	0.055	0.059
	15	10			0.044	0.050	0.056	0.063	0.069	0.074
	15	10			0.035	0.040	0.045	0.050	0.055	0.059
	15	10			0.035	0.040	0.045	0.050	0.055	0.059
	80	80	80		0.078	0.087	0.098	0.109	0.120	0.128
	30	30	30		0.053	0.059	0.067	0.075	0.083	0.089

The specified cutting data are guide values.

The optimum data for the respective machining task should be determined during the test or machining.

Cutting data recommendation for pilot drills and deep drills

Feed and cutting speed

MICRO-Step-Drill-Steel | SCD581

MMG*		Workpiece material	Strength/hardness [N/mm ²] [HRC]
P	P1	P1.1 Structural, machining, case hardened and tempering steels, unalloyed	< 700
		P1.2 Structural, machining, case hardened and tempering steels, unalloyed	< 1,200
	P2	P2.1 Nitriding, hardening and tempering steels, alloyed	< 900
		P2.2 Nitriding, hardening and tempering steels, alloyed	< 1,400
	P3	P3.1 Tool, bearing, spring and high-speed steels**	< 800
		P3.2 Tool, bearing, spring and high-speed steels**	< 1,000
		P3.3 Tool, bearing, spring and high-speed steels**	< 1,500
	P5	P5.1 Cast steel	
M	M1	M1.1 Stainless steels, austenitic	< 700
		M1.2 Stainless steels, ferritic/austenitic (duplex)	< 1,000
K	K1	K1.1 Cast iron with lamellar graphite (grey cast iron), GJL	< 300
		K2.1 Cast iron with spheroidal graphite, GJS	< 500
	K2	K2.2 Cast iron with spheroidal graphite, GJS	≤ 800
		K2.3 Cast iron with spheroidal graphite, GJS	> 800
	K3	K3.1 Cast iron with vermicular graphite, GJV; malleable cast iron, GJM	< 500
		K3.2 Cast iron with vermicular graphite, GJV; malleable cast iron, GJM	> 500

MICRO-Deep-Drill | SCD171

MMG*		Workpiece material	Strength/hardness [N/mm ²] [HRC]
P	P1	P1.1 Structural, machining, case hardened and tempering steels, unalloyed	< 700
		P1.2 Structural, machining, case hardened and tempering steels, unalloyed	< 1,200
	P2	P2.1 Nitriding, hardening and tempering steels, alloyed	< 900
		P2.2 Nitriding, hardening and tempering steels, alloyed	< 1,400
	P3	P3.1 Tool, bearing, spring and high-speed steels**	< 800
		P3.2 Tool, bearing, spring and high-speed steels**	< 1,000
		P3.3 Tool, bearing, spring and high-speed steels**	< 1,500
	P5	P5.1 Cast steel	
K	K1	K1.1 Cast iron with lamellar graphite (grey cast iron), GJL	< 300
		K2.1 Cast iron with spheroidal graphite, GJS	< 500
	K2	K2.2 Cast iron with spheroidal graphite, GJS	≤ 800
		K2.3 Cast iron with spheroidal graphite, GJS	> 800
	K3	K3.1 Cast iron with vermicular graphite, GJV; malleable cast iron, GJM	< 500
		K3.2 Cast iron with vermicular graphite, GJV; malleable cast iron, GJM	> 500

* MAPAL Machining Groups

** If the alloy parts Cr, Mo, Ni, V, W in total > 8%, then select the next highest MAPAL machining group.

	Cutting speed v_c [m/min]				Feed f [mm] for drill diameter					
	Internal cooling	External cooling	MQL	Air	1.00	1.20	1.60	1.90	2.40	3.00
	80	70	70		0.05	0.06	0.06	0.07	0.08	0.09
	70	60	60		0.07	0.07	0.08	0.09	0.10	0.11
	80	70	70		0.06	0.07	0.08	0.08	0.10	0.11
	55	50	50		0.06	0.06	0.07	0.07	0.08	0.09
	60	50	50		0.06	0.06	0.07	0.07	0.08	0.10
	50	45	45		0.05	0.05	0.06	0.07	0.07	0.08
	50	35	40		0.05	0.05	0.05	0.06	0.06	0.07
	80	70	70		0.06	0.07	0.08	0.08	0.10	0.11
	45	30	30		0.04	0.04	0.05	0.05	0.06	0.06
	95	70	70	70	0.06	0.07	0.08	0.09	0.10	0.12
	130	80	95	95	0.07	0.07	0.08	0.09	0.11	0.13
	80	60	60		0.06	0.07	0.08	0.09	0.10	0.11
	70	65	65		0.07	0.08	0.08	0.09	0.11	0.12
	65	55	55		0.06	0.07	0.08	0.08	0.09	0.11

	Cutting speed v_c [m/min]			Feed f [mm] for drill diameter					
	Internal cooling	MQL	Air	1.00	2.00	4.00	6.00	9.00	16.00
	90	80		0.04	0.06	0.09	0.13	0.19	0.27
	80	70		0.06	0.08	0.11	0.16	0.24	0.34
	90	75		0.05	0.07	0.10	0.16	0.23	0.32
	65	55		0.05	0.07	0.09	0.13	0.18	0.25
	70	60		0.05	0.06	0.09	0.14	0.21	0.29
	55	50		0.04	0.06	0.08	0.12	0.17	0.23
	55	45		0.04	0.05	0.07	0.09	0.13	0.18
	90	75		0.05	0.07	0.10	0.16	0.23	0.32
	110	75	75	0.14	0.18	0.25	0.32	0.41	0.53
	145	110	110	0.14	0.18	0.24	0.30	0.38	0.49
	90	70		0.13	0.16	0.21	0.26	0.33	0.42
	55	45		0.10	0.12	0.14	0.18	0.22	0.28
	80	70		0.14	0.18	0.22	0.28	0.36	0.46
	70	65		0.12	0.15	0.18	0.23	0.29	0.36

The specified cutting data are guide values.

The optimum data for the respective machining task should be determined during the test or machining.

Cutting data recommendations for drill reamer

Feed and cutting speed

MEGA-Drill-Reamer-Pyramid | SCD651

MMG*		Workpiece material	Strength/hardness [N/mm ²] [HRC]
P	P1	P1.1 Structural, machining, case hardened and tempering steels, unalloyed	< 700
		P1.2 Structural, machining, case hardened and tempering steels, unalloyed	< 1,200
	P2	P2.1 Nitriding, hardening and tempering steels, alloyed	< 900
		P2.2 Nitriding, hardening and tempering steels, alloyed	< 1,400
	P3	P3.1 Tool, bearing, spring and high-speed steels**	< 800
		P3.2 Tool, bearing, spring and high-speed steels**	< 1,000
		P3.3 Tool, bearing, spring and high-speed steels**	< 1,500
	P4	P4.1 Stainless steels, ferritic and martensitic	
	P5	P5.1 Cast steel	
	P6	P6.1 Stainless cast steels, ferritic and martensitic	
K	K1	K1.1 Cast iron with lamellar graphite (grey cast iron), GJL	< 300
		K2.1 Cast iron with spheroidal graphite, GJS	< 500
	K2	K2.2 Cast iron with spheroidal graphite, GJS	≤ 800
		K2.3 Cast iron with spheroidal graphite, GJS	> 800
	K3	K3.1 Cast iron with vermicular graphite, GJV; malleable cast iron, GJM	< 500
		K3.2 Cast iron with vermicular graphite, GJV; malleable cast iron, GJM	> 500

* MAPAL Machining Groups

** If the alloy parts Cr, Mo, Ni, V, W in total > 8%, then select the next highest MAPAL machining group.

	Cutting speed v_c [m/min]				Feed f [mm] for drill diameter					
	Internal cooling	External cooling	MQL	Air	3.00	4.50	6.50	9.50	14.00	20.00
	80	70	70		0.11	0.13	0.14	0.15	0.17	0.19
	70	60	60		0.14	0.16	0.17	0.19	0.21	0.23
	80	70	70		0.13	0.15	0.16	0.18	0.20	0.22
	55	50	50		0.11	0.12	0.13	0.15	0.16	0.18
	60	50	50		0.12	0.13	0.15	0.16	0.18	0.20
	50	45	45		0.10	0.11	0.12	0.14	0.15	0.16
	80	70	70		0.13	0.15	0.16	0.18	0.20	0.22
	95	70	70	70	0.17	0.19	0.22	0.25	0.27	0.30
	130	80	95	95	0.16	0.19	0.20	0.23	0.26	0.28
	80	60	60		0.14	0.16	0.18	0.20	0.22	0.24
	70	65	65		0.16	0.17	0.19	0.22	0.24	0.26
	65	55	55		0.13	0.14	0.16	0.17	0.19	0.21

The specified cutting data are guide values.

The optimum data for the respective machining task should be determined during the test or machining.

Cutting data recommendations for drill reamer

Feed and cutting speed

Tritan-Drill-Reamer | SDR301

MMG*		Workpiece material	Strength/hardness [N/mm ²] [HRC]
P	P1	P1.1 Structural, machining, case hardened and tempering steels, unalloyed	< 700
		P1.2 Structural, machining, case hardened and tempering steels, unalloyed	< 1,200
	P2	P2.1 Nitriding, hardening and tempering steels, alloyed	< 900
		P2.2 Nitriding, hardening and tempering steels, alloyed	< 1,400
	P3	P3.1 Tool, bearing, spring and high-speed steels**	< 800
		P3.2 Tool, bearing, spring and high-speed steels**	< 1,000
		P3.3 Tool, bearing, spring and high-speed steels**	< 1,500
	P5	P5.1 Cast steel	
K	K1	K1.1 Cast iron with lamellar graphite (grey cast iron), GJL	< 300
		K1.2 Cast iron with spheroidal graphite, GJS	< 500
	K2	K2.2 Cast iron with spheroidal graphite, GJS	≤ 800
		K2.3 Cast iron with spheroidal graphite, GJS	> 800
	K3	K3.1 Cast iron with vermicular graphite, GJV; malleable cast iron, GJM	< 500
		K3.2 Cast iron with vermicular graphite, GJV; malleable cast iron, GJM	> 500

EXAMPLE CALCULATION

Please note that the result may be influenced by additional parameters such as the machine tool or tool clamping.

Formula for calculating the optimum nominal tool diameter:

$$(G_{OB} + G_{UB}) / 2$$

Example:

- Fitting bore: \varnothing 10 F7
- Maximum bore dimension G_{OB} : 10.028 mm
- Minimum bore dimension G_{UB} : 10.013 mm

$$\rightarrow (10.028 \text{ mm} + 10.013 \text{ mm}) / 2 = 10.021 \text{ mm} = \text{selection of tool nominal diameter } 10.021 \text{ mm}$$

* MAPAL Machining Groups

** If the alloy parts Cr, Mo, Ni, V, W in total > 8%, then select the next highest MAPAL machining group.

	Cutting speed v_c [m/min]				Feed f [mm] for drill diameter					
	Internal cooling	External cooling	MQL	Air	4.00	5.50	7.50	10.50	14.50	20.00
	70	65	65		0.17	0.22	0.27	0.34	0.41	0.47
	65	55	55		0.22	0.27	0.34	0.42	0.51	0.59
	70	60	60		0.20	0.26	0.32	0.40	0.48	0.56
	50	40	40		0.17	0.21	0.26	0.32	0.38	0.44
	55	45	45		0.18	0.23	0.29	0.36	0.43	0.50
	40	40	40		0.15	0.19	0.24	0.30	0.36	0.41
	40	30	35		0.13	0.16	0.19	0.23	0.28	0.32
	70	60	60		0.20	0.26	0.32	0.40	0.48	0.56
	100	70	70	70	0.25	0.33	0.42	0.55	0.67	0.79
	135	85	100	100	0.24	0.32	0.40	0.51	0.62	0.72
	85	65	65		0.22	0.28	0.35	0.44	0.54	0.62
	50	35	45		0.11	0.13	0.16	0.20	0.24	0.28
	75	70	70		0.23	0.30	0.38	0.47	0.58	0.67
	70	60	60		0.20	0.25	0.31	0.38	0.46	0.53

The specified cutting data are guide values.

The optimum data for the respective machining task should be determined during the test or machining.

Cutting data recommendations for QTD indexable inserts

Feed and cutting speed

QTD - Type 01 - Steel

MMG*		Workpiece material	Strength/hardness [N/mm ²] [HRC]
P	P1	P1.1 Structural, machining, case hardened and tempering steels, unalloyed	< 700
		P1.2 Structural, machining, case hardened and tempering steels, unalloyed	< 1,200
	P2	P2.1 Nitriding, hardening and tempering steels, alloyed	< 900
		P2.2 Nitriding, hardening and tempering steels, alloyed	< 1,400
	P3	P3.1 Tool, bearing, spring and high-speed steels**	< 800
		P3.2 Tool, bearing, spring and high-speed steels**	< 1,000
		P3.3 Tool, bearing, spring and high-speed steels**	< 1,500
	P4	P4.1 Stainless steels, ferritic and martensitic	
	P5	P5.1 Cast steel	
	P6	P6.1 Stainless cast steels, ferritic and martensitic	
K	K1	K1.1 Cast iron with lamellar graphite (grey cast iron), GJL	< 300
		K2.1 Cast iron with spheroidal graphite, GJS	< 500
	K2	K2.2 Cast iron with spheroidal graphite, GJS	≤ 800
		K2.3 Cast iron with spheroidal graphite, GJS	> 800

* MAPAL Machining Groups

** If the alloy parts Cr, Mo, Ni, V, W in total > 8%, then select the next highest MAPAL machining group.

	Cutting speed v_c [m/min]				Feed f [mm] for drill diameter					
	Internal cooling	External cooling	MQL	Air	8.00	11.50	16.50	24.00	34.50	50.00
	100	90	90		0.20	0.26	0.31	0.36	0.38	0.39
	90	75	75		0.25	0.32	0.39	0.45	0.47	0.49
	100	85	85		0.24	0.30	0.37	0.43	0.45	0.46
	70	60	60		0.19	0.24	0.29	0.34	0.35	0.36
	75	65	65		0.22	0.27	0.33	0.38	0.40	0.42
	60	55	55		0.18	0.22	0.27	0.31	0.33	0.34
	60	45	50		0.14	0.18	0.21	0.24	0.25	0.26
	60	45	50		0.14	0.18	0.22	0.25	0.27	0.27
	100	85	85		0.24	0.30	0.37	0.43	0.45	0.46
	60	45	50		0.14	0.18	0.22	0.25	0.27	0.27
	95	70	70	70	0.25	0.33	0.41	0.47	0.49	0.51
	130	80	95	95	0.24	0.30	0.37	0.43	0.46	0.47
	80	60	60		0.21	0.26	0.32	0.37	0.39	0.40

The specified cutting data are guide values.

The optimum data for the respective machining task should be determined during the test or machining.

Cutting data recommendations for countersinks

Feed and cutting speed

COS110 | HSS-coated

MMG*	Workpiece material	Strength/hardness [N/mm ²] [HRC]
P	P1.1 Structural, machining, case hardened and tempering steels, unalloyed	< 700
	P1.2 Structural, machining, case hardened and tempering steels, unalloyed	< 1,200
	P2.1 Nitriding, hardening and tempering steels, alloyed	< 900
	P2.2 Nitriding, hardening and tempering steels, alloyed	< 1,400
	P3.1 Tool, bearing, spring and high-speed steels**	< 800
	P3.2 Tool, bearing, spring and high-speed steels**	< 1,000
	P3.3 Tool, bearing, spring and high-speed steels**	< 1,500
	P4.1 Stainless steels, ferritic and martensitic	
P5.1 Cast steel		
P6.1 Stainless cast steel, ferritic and martensitic		
M	M1.1 Stainless steels, austenitic	< 700
	M1.2 Stainless steels, ferritic/austenitic (duplex)	< 1,000
	M2.1 Stainless cast steel, austenitic	< 700
	M3.1 Stainless cast steel, ferritic/austenitic (duplex)	< 1,000
K	K1.1 Cast iron with lamellar graphite (grey cast iron), GJL	< 300
	K2.1 Cast iron with spheroidal graphite, GJS	< 500
	K2.2 Cast iron with spheroidal graphite, GJS	≤ 800
	K2.3 Cast iron with spheroidal graphite, GJS	> 800
	K3.1 Cast iron with vermicular graphite, GJV; malleable cast iron, GJM	< 500
	K3.2 Cast iron with vermicular graphite, GJV; malleable cast iron, GJM	> 500
N	N1.1 Aluminium, unalloyed and alloyed < 3 % Si	
	N1.2 Aluminium, alloyed ≤ 7 % Si	
	N1.3 Aluminium, alloyed > 7-12 % Si	
	N1.4 Aluminium, alloyed > 12 % Si	
	N2.1 Copper, unalloyed and low alloyed	< 300
	N2.2 Copper, alloyed	> 300
	N2.3 Brass, bronze, gunmetal	< 1,200
	N4.1 Plastic, thermoplastics	
	N4.2 Plastic, duroplastics	
	N4.3 Plastic, foam materials	
S	S1.1 Titanium, titanium alloys	< 400
	S2.1 Titanium, titanium alloys	< 1,200
	S2.2 Titanium, titanium alloys	> 1,200
	S3.1 Nickel, unalloyed and alloyed	< 900
	S3.2 Nickel, unalloyed and alloyed	> 900
	S4.1 High-temperature super alloy, Ni-, Co-, and Fe-based	
S5.1 Molybdenum and tungsten alloys		
H	H1.1 Hardened steel / cast steel	< 44 HRC
	H1.2 Hardened steel / cast steel	< 55 HRC

* MAPAL Machining Groups

** If the alloy parts Cr, Mo, Ni, V, W in total > 8%, then select the next highest MAPAL machining group.

Next page:
Solid carbide version

	ø < 5 [mm]		ø < 5-8 [mm]		ø < 8-12 [mm]		ø < 12-16 [mm]		ø < 16-20 [mm]		ø < 20-25 [mm]		ø < 25-31 [mm]	
	v _c [m/min]	f [mm/U]	v _c [m/min]	f [mm/U]	v _c [m/min]	f [mm/U]	v _c [m/min]	f [mm/U]	v _c [m/min]	f [mm/U]	v _c [m/min]	f [mm/U]	v _c [m/min]	f [mm/U]
	40	0.06	40	0.08	40	0.10	40	0.12	40	0.14	40	0.18	40	0.22
	30	0.04	30	0.06	30	0.08	30	0.10	30	0.12	30	0.14	30	0.18
	30	0.04	30	0.06	30	0.08	30	0.10	30	0.12	30	0.14	30	0.18
	12	0.03	12	0.04	12	0.05	12	0.06	12	0.08	12	0.10	12	0.12
	30	0.04	30	0.06	30	0.08	30	0.10	30	0.12	30	0.14	30	0.18
	12	0.03	12	0.04	12	0.05	12	0.06	12	0.08	12	0.10	12	0.12
	15	0.04	15	0.05	15	0.06	15	0.07	15	0.08	15	0.09	15	0.12
	30	0.04	30	0.06	30	0.08	30	0.10	30	0.12	30	0.14	30	0.18
	15	0.04	15	0.05	15	0.06	15	0.07	15	0.08	15	0.09	15	0.12
	15	0.04	15	0.05	15	0.06	15	0.07	15	0.08	15	0.09	15	0.12
	10	0.04	10	0.05	10	0.06	10	0.07	10	0.08	10	0.09	10	0.12
	15	0.04	15	0.05	15	0.06	15	0.07	15	0.08	15	0.09	15	0.12
	20	0.06	20	0.10	20	0.12	20	0.14	20	0.18	20	0.20	20	0.25
	20	0.06	20	0.10	20	0.12	20	0.14	20	0.18	20	0.20	20	0.25
	20	0.06	20	0.10	20	0.12	20	0.14	20	0.18	20	0.20	20	0.25
	20	0.06	20	0.10	20	0.12	20	0.14	20	0.18	20	0.20	20	0.25
	20	0.06	20	0.10	20	0.12	20	0.14	20	0.18	20	0.20	20	0.25
	20	0.06	20	0.10	20	0.12	20	0.14	20	0.18	20	0.20	20	0.25
	50	0.08	50	0.10	50	0.12	50	0.14	50	0.18	50	0.22	50	0.26
	50	0.08	50	0.10	50	0.12	50	0.14	50	0.18	50	0.22	50	0.26
	40	0.08	40	0.10	40	0.12	40	0.14	40	0.18	40	0.22	40	0.26
	40	0.08	40	0.10	40	0.12	40	0.14	40	0.18	40	0.22	40	0.26
	40	0.10	40	0.12	40	0.14	40	0.18	40	0.20	40	0.24	40	0.30
	40	0.10	40	0.12	40	0.14	40	0.18	40	0.20	40	0.24	40	0.30
	40	0.10	40	0.12	40	0.14	40	0.18	40	0.20	40	0.24	40	0.30
	40	0.10	40	0.12	40	0.14	40	0.18	40	0.20	40	0.24	40	0.30
	40	0.10	40	0.12	40	0.14	40	0.18	40	0.20	40	0.24	40	0.30
	10	0.04	10	0.05	10	0.06	10	0.07	10	0.08	10	0.09	10	0.12
	10	0.04	10	0.05	10	0.06	10	0.07	10	0.08	10	0.09	10	0.12
	10	0.04	10	0.05	10	0.06	10	0.07	10	0.08	10	0.09	10	0.12
	10	0.04	10	0.05	10	0.06	10	0.07	10	0.08	10	0.09	10	0.12
	10	0.04	10	0.05	10	0.06	10	0.07	10	0.08	10	0.09	10	0.12
	10	0.04	10	0.05	10	0.06	10	0.07	10	0.08	10	0.09	10	0.12
	10	0.04	10	0.05	10	0.06	10	0.07	10	0.08	10	0.09	10	0.12
	6	0.04	6	0.05	6	0.06	6	0.08	6	0.08	6	0.10		
	6	0.04	6	0.05	6	0.06	6	0.08	6	0.08	6	0.10		

The specified cutting data are guide values.
The optimum data for the respective machining task should be determined during the test or machining.

Cutting data recommendations for countersinks

Feed and cutting speed

COS110 | Solid-carbide coated

MMG*		Workpiece material	Strength/hardness [N/mm ²] [HRC]	
P	P1	P1.1 Structural, machining, case hardened and tempering steels, unalloyed	< 700	
		P1.2 Structural, machining, case hardened and tempering steels, unalloyed	< 1,200	
	P2	P2.1 Nitriding, hardening and tempering steels, alloyed	< 900	
		P2.2 Nitriding, hardening and tempering steels, alloyed	< 1,400	
	P3	P3.1 Tool, bearing, spring and high-speed steels**	< 800	
		P3.2 Tool, bearing, spring and high-speed steels**	< 1,000	
P3.3 Tool, bearing, spring and high-speed steels**		< 1,500		
P4	P4.1 Stainless steels, ferritic and martensitic			
P5	P5.1 Cast steel			
P6	P6.1 Stainless cast steel, ferritic and martensitic			
M	M1	M1.1 Stainless steels, austenitic	< 700	
		M1.2 Stainless steels, ferritic/austenitic (duplex)	< 1,000	
	M2	M2.1 Stainless cast steel, austenitic	< 700	
	M3	M3.1 Stainless cast steel, ferritic/austenitic (duplex)	< 1,000	
K	K1	K1.1 Cast iron with lamellar graphite (grey cast iron), GJL	< 300	
		K2.1 Cast iron with spheroidal graphite, GJS	< 500	
		K2.2 Cast iron with spheroidal graphite, GJS	≤ 800	
	K2	K2.3 Cast iron with spheroidal graphite, GJS	> 800	
		K3	K3.1 Cast iron with vermicular graphite, GJV; malleable cast iron, GJM	< 500
			K3.2 Cast iron with vermicular graphite, GJV; malleable cast iron, GJM	> 500
N	N1	N1.1 Aluminium, unalloyed and alloyed < 3 % Si		
		N1.2 Aluminium, alloyed ≤ 7 % Si		
		N1.3 Aluminium, alloyed > 7-12 % Si		
		N1.4 Aluminium, alloyed > 12 % Si		
	N2	N2.1 Copper, unalloyed and low alloyed	< 300	
		N2.2 Copper, alloyed	> 300	
		N2.3 Brass, bronze, gunmetal	< 1,200	
	N3	N3.1 Graphite > 8 µm		
		N3.2 Graphite < 8 µm		
	N4	N4.1 Plastic, thermoplastics		
		N4.2 Plastic, duroplastics		
		N4.3 Plastic, foam materials		
	C	C1	C1.1 Plastic range, reinforced with aramid fibre (AFK)	
			C1.2 Plastic range (duroplastic), CFK/GFK	
C1.3 Plastic range (thermoplastic), CFK/GFK				
C2		C2.1 Carbon range, reinforced with carbon fibre (CFC)		
		C3	C3.1 Metal matrix (MMC)	
			C4.1 Sandwich construction, honeycomb core made from paper	
			C4.2 Sandwich construction, honeycomb core made from aluminium	
C4		C4.3 Sandwich construction, honeycomb core made from plastic and fibre composite material		
		C4.4 Sandwich construction, core made from rigid foam sheets		
		C5	C5.1 Stack (hybrid structure), CFK aluminium	
C5.2 Stack (hybrid structure), CFK titanium/stainless steel				
S	S1	S1.1 Titanium, titanium alloys	< 400	
		S2.1 Titanium, titanium alloys	< 1,200	
	S2	S2.2 Titanium, titanium alloys	> 1,200	
		S3	S3.1 Nickel, unalloyed and alloyed	< 900
	S3.2 Nickel, unalloyed and alloyed		> 900	
	S4	S4.1 High-temperature super alloy, Ni-, Co-, and Fe-based		
S5	S5.1 Molybdenum and tungsten alloys			
H	H1	H1.1 Hardened steel / cast steel	< 44 HRC	
		H1.2 Hardened steel / cast steel	< 55 HRC	
		H2.1 Hardened steel / cast steel	< 60 HRC	
	H2	H2.2 Hardened steel / cast steel	< 65 HRC	
		H2.3 Hardened steel / cast steel	< 68 HRC	
H3	H3.1 Wear-resistant cast/chill casting, GJN			

* MAPAL Machining Groups

** If the alloy parts Cr, Mo, Ni, V, W in total > 8%, then select the next highest MAPAL machining group.

	ø < 5 [mm]		ø < 5-8 [mm]		ø < 8-12 [mm]		ø < 12-16 [mm]		ø < 16-20 [mm]		ø < 20-25 [mm]		ø < 25-31 [mm]	
	v _c [m/min]	f [mm/U]	v _c [m/min]	f [mm/U]	v _c [m/min]	f [mm/U]	v _c [m/min]	f [mm/U]	v _c [m/min]	f [mm/U]	v _c [m/min]	f [mm/U]	v _c [m/min]	f [mm/U]
	60	0.06	60	0.08	60	0.10	60	0.12	60	0.14	60	0.18	60	0.22
	50	0.04	50	0.06	50	0.08	50	0.10	50	0.12	50	0.14	50	0.18
	50	0.04	50	0.06	50	0.08	50	0.10	50	0.12	50	0.14	50	0.18
	40	0.03	40	0.04	40	0.05	40	0.06	40	0.08	40	0.10	40	0.12
	50	0.04	50	0.06	50	0.08	50	0.10	50	0.12	50	0.14	50	0.18
	40	0.03	40	0.04	40	0.05	40	0.06	40	0.08	40	0.10	40	0.12
	30	0.04	30	0.05	30	0.06	30	0.07	30	0.08	30	0.09	30	0.12
	50	0.04	50	0.06	50	0.08	50	0.10	50	0.12	50	0.14	50	0.18
	30	0.04	30	0.05	30	0.06	30	0.07	30	0.08	30	0.09	30	0.12
	30	0.04	30	0.05	30	0.06	30	0.07	30	0.08	30	0.09	30	0.12
	25	0.04	25	0.05	25	0.06	25	0.07	25	0.08	25	0.09	25	0.12
	30	0.04	30	0.05	30	0.06	30	0.07	30	0.08	30	0.09	30	0.12
	25	0.04	25	0.05	25	0.06	25	0.07	25	0.08	25	0.09	25	0.12
	50	0.06	50	0.10	50	0.12	50	0.14	50	0.18	50	0.20	50	0.25
	45	0.06	45	0.10	45	0.12	45	0.14	45	0.18	45	0.20	45	0.25
	45	0.06	45	0.10	45	0.12	45	0.14	45	0.18	45	0.20	45	0.25
	45	0.06	45	0.10	45	0.12	45	0.14	45	0.18	45	0.20	45	0.25
	35	0.06	35	0.10	35	0.12	35	0.14	35	0.18	35	0.20	35	0.25
	35	0.06	35	0.10	35	0.12	35	0.14	35	0.18	35	0.20	35	0.25
	80	0.08	80	0.10	80	0.12	80	0.14	80	0.18	80	0.22	80	0.26
	80	0.08	80	0.10	80	0.12	80	0.14	80	0.18	80	0.22	80	0.26
	60	0.08	60	0.10	60	0.12	60	0.14	60	0.18	60	0.22	60	0.26
	60	0.08	60	0.10	60	0.12	60	0.14	60	0.18	60	0.22	60	0.26
	70	0.10	70	0.12	70	0.14	70	0.18	70	0.20	70	0.24	70	0.30
	70	0.10	70	0.12	70	0.14	70	0.18	70	0.20	70	0.24	70	0.30
	70	0.10	70	0.12	70	0.14	70	0.18	70	0.20	70	0.24	70	0.30
	25	0.06	25	0.10	25	0.12	25	0.14	25	0.18	25	0.20	25	0.25
	25	0.06	25	0.10	25	0.12	25	0.14	25	0.18	25	0.20	25	0.25
	70	0.10	70	0.12	70	0.14	70	0.18	70	0.20	70	0.24	70	0.30
	70	0.10	70	0.12	70	0.14	70	0.18	70	0.20	70	0.24	70	0.30
	70	0.10	70	0.12	70	0.14	70	0.18	70	0.20	70	0.24	70	0.30
	25	0.06	25	0.10	25	0.12	25	0.14	25	0.18	25	0.20	25	0.25
	25	0.06	25	0.10	25	0.12	25	0.14	25	0.18	25	0.20	25	0.25
	25	0.06	25	0.10	25	0.12	25	0.14	25	0.18	25	0.20	25	0.25
	25	0.06	25	0.10	25	0.12	25	0.14	25	0.18	25	0.20	25	0.25
	25	0.06	25	0.10	25	0.12	25	0.14	25	0.18	25	0.20	25	0.25
	25	0.06	25	0.10	25	0.12	25	0.14	25	0.18	25	0.20	25	0.25
	25	0.06	25	0.10	25	0.12	25	0.14	25	0.18	25	0.20	25	0.25
	25	0.06	25	0.10	25	0.12	25	0.14	25	0.18	25	0.20	25	0.25
	25	0.06	25	0.10	25	0.12	25	0.14	25	0.18	25	0.20	25	0.25
	15	0.04	15	0.05	15	0.06	15	0.07	15	0.08	15	0.09	15	0.12
	15	0.04	15	0.05	15	0.06	15	0.07	15	0.08	15	0.09	15	0.12
	15	0.04	15	0.05	15	0.06	15	0.07	15	0.08	15	0.09	15	0.12
	15	0.04	15	0.05	15	0.06	15	0.07	15	0.08	15	0.09	15	0.12
	15	0.04	15	0.05	15	0.06	15	0.07	15	0.08	15	0.09	15	0.12
	15	0.04	15	0.05	15	0.06	15	0.07	15	0.08	15	0.09	15	0.12
	12	0.04	12	0.05	12	0.06	12	0.08	12	0.08	12	0.10		
	12	0.04	12	0.05	12	0.06	12	0.08	12	0.08	12	0.10		
	8	0.04	8	0.05	8	0.06	8	0.08	8	0.08	8	0.10		
	8	0.04	8	0.05	8	0.06	8	0.08	8	0.08	8	0.10		
	12	0.04	12	0.05	12	0.06	12	0.08	12	0.08	12	0.10		

The specified cutting data are guide values.
 The optimum data for the respective machining task should be determined during the test or machining.



REAMING

Fixed multi-bladed reamers and tools with guide pads.

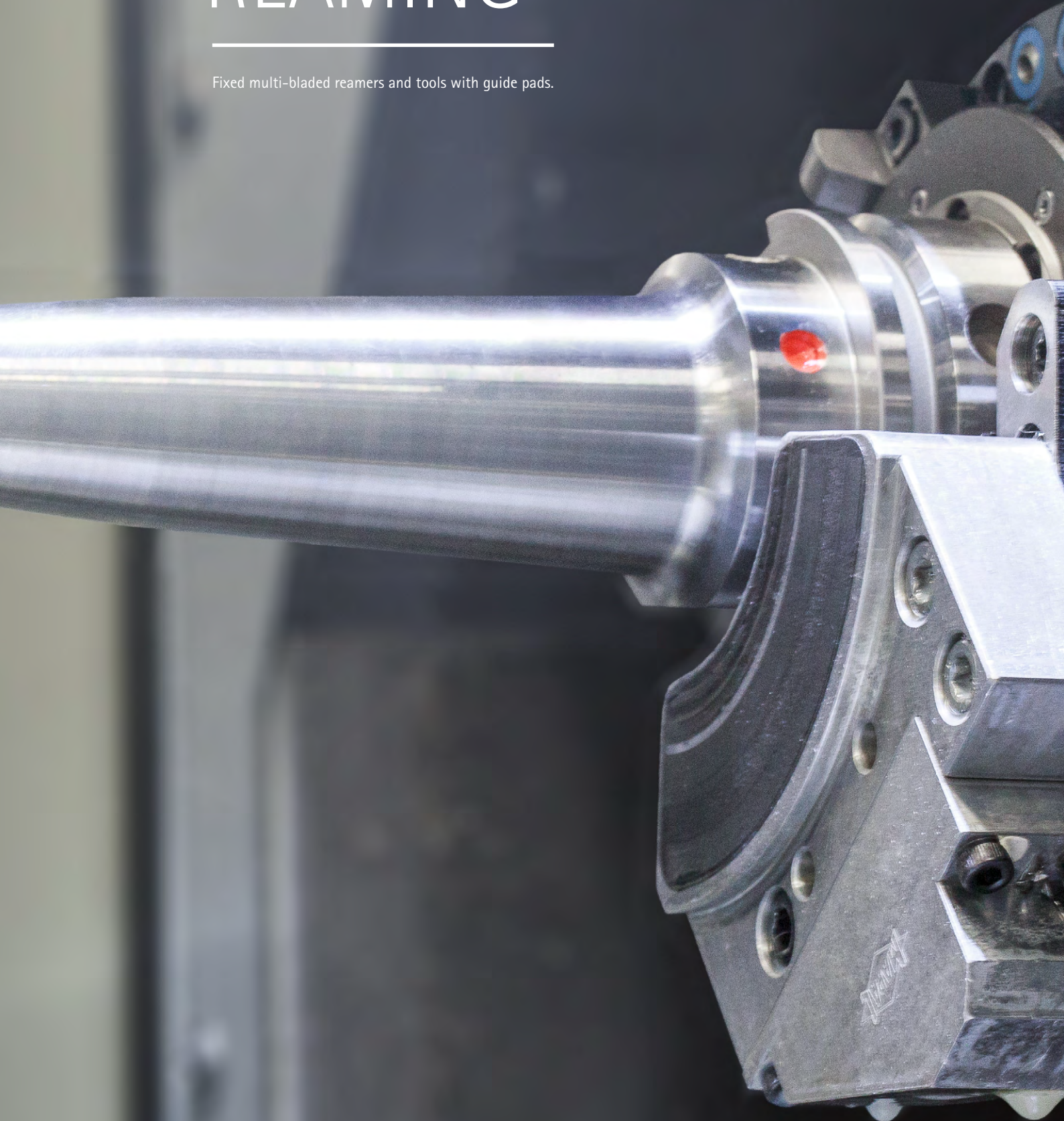

PRODUCT OVERVIEW

Reaming

The FixReam high-performance reamer series made of solid carbide covers a wide range of applications and has already proved itself many times in steel and cast machining.

Depending on the diameter, the high-performance reamers made of solid carbide have between four and eight cutting edges with internal cooling and achieve correspondingly high feed rates.

All tools have an internal coolant supply. Through and blind bores can be machined economically and reliably.

The preferred series in H7 is available from stock. If the desired dimension is not available, the reamers can be configured individually using the specified configuration key.



Fixed multi-bladed reamers



FixReam - FXR

- High-performance reamers with a cylindrical shank
- Reliable machining of the contour in IT7 tolerances
- No setting effort
- High feed rates
- Short cycle times
- Straight fluted for through and blind bore
- Left-hand fluted for through bores
- Internal cooling
- Preferred series available from stock in H7

Ø area: 2.800 - 20.200 mm



COMPETENCE IN REAMING AND FINE BORING



Thanks to decades of experience and the continuous further development and optimisation of tool solutions, MAPAL is today pleased to offer a varied standard range of tools for reaming and fine boring in addition to tailor-made special solutions.



You can find the complete MAPAL portfolio in our catalogue
"BORE MACHINING"

Can now be browsed and downloaded
as a PDF at www.mapal.com



Product ID codes

Fixed multi-bladed reamers

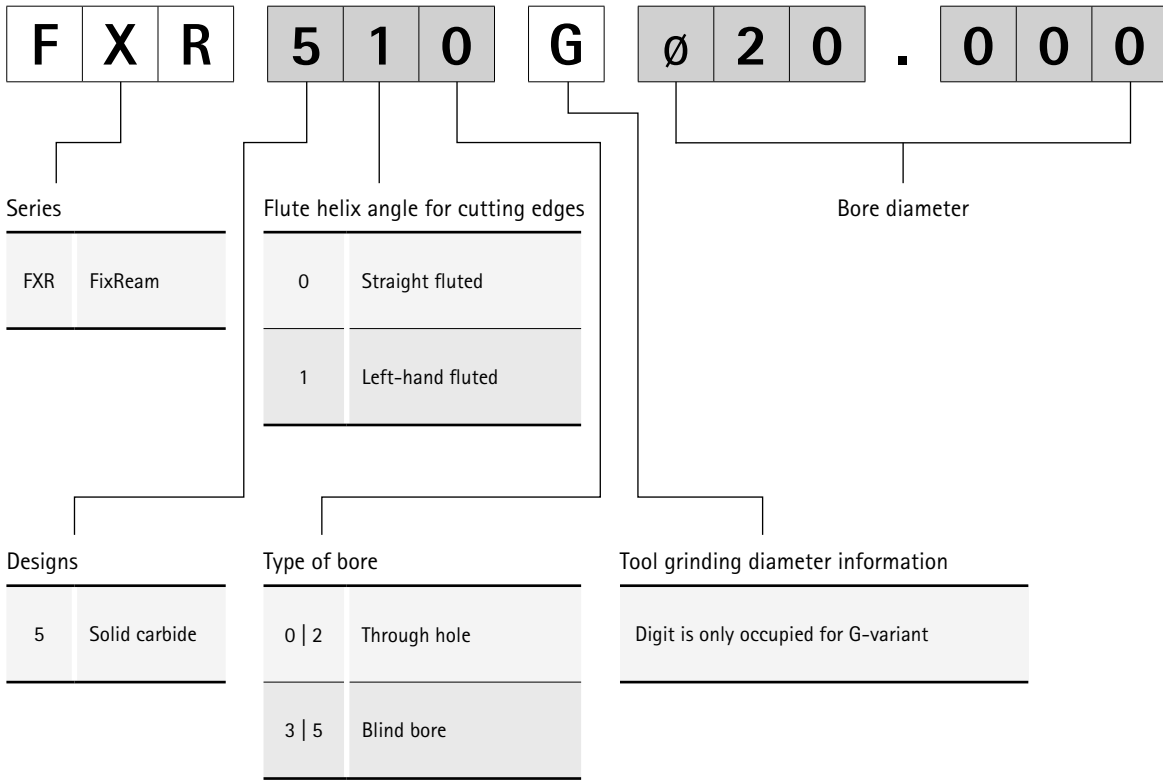

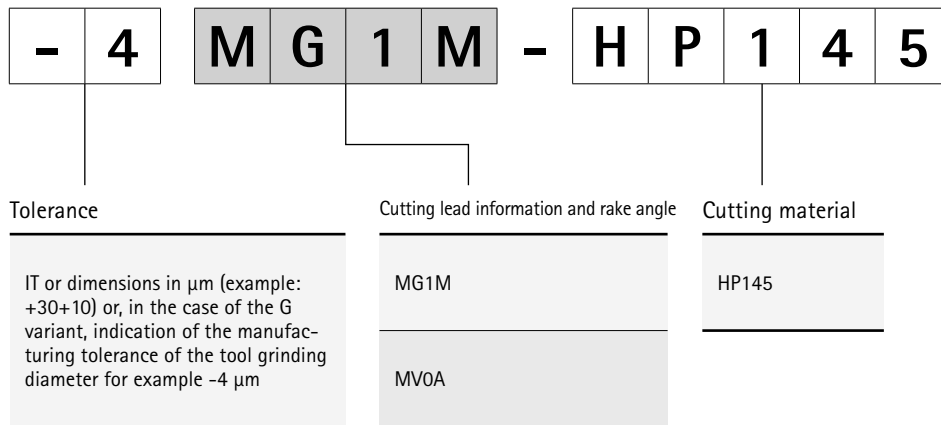

Tolerances for the G variant/fixed variant FXR5XX:

Cutting material	Diameter range
Coated (layer thickness 2-4 μm)	-0.005
HP141	

Explanation of the G variant FXR

Permissible workpiece tolerances for selecting the tool diameter.

G variant design:

The G variant indicates the tool diameter of the reamer with our manufacturing tolerances. The manufacturing tolerances depend on the cutting material; see permissible smallest tolerances for the G variant.



REAMING

High-performance reamers - FixReam

FXR510, for through bore 438

FXR505, for blind bore 440

Technical appendix

Cutting data recommendations 442

FixReam

Fixed design, left-hand fluted, for through bore FXR510

Design:

Reamer diameter: 2.800 - 20.200 mm
 Lead: MG1M
 Cutting material: HP145 Carbide
 PVD-coated

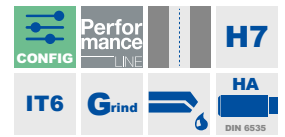
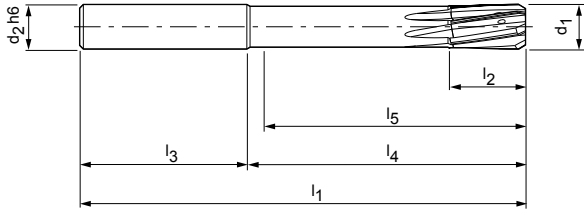

Preferred series in H7

d ₁ H7	Dimensions						z	Specification	Order no.
	d ₂ h6	l ₁	l ₂	l ₃	l ₄	l ₅			
4,000	6	75	12	36	39	34	4	FXR510Ø4.000H7MG1M-HP145	30570722
5,000	6	75	12	36	39	35	4	FXR510Ø5.000H7MG1M-HP145	30570724
6,000	6	75	12	36	39	35	4	FXR510Ø6.000H7MG1M-HP145	30570726
7,000	8	100	16	36	64	59	6	FXR510Ø7.000H7MG1M-HP145	30570728
8,000	8	100	16	36	64	60	6	FXR510Ø8.000H7MG1M-HP145	30570730
9,000	10	100	20	40	60	55	6	FXR510Ø9.000H7MG1M-HP145	30570732
10,000	10	120	20	40	80	76	6	FXR510Ø10.000H7MG1M-HP145	30570734
11,000	12	120	20	45	75	70	6	FXR510Ø11.000H7MG1M-HP145	30570736
12,000	12	120	20	45	75	71	6	FXR510Ø12.000H7MG1M-HP145	30570738
13,000	14	130	22	45	85	80	6	FXR510Ø13.000H7MG1M-HP145	30570739
14,000	14	130	22	45	85	80	6	FXR510Ø14.000H7MG1M-HP145	30570740
15,000	16	130	22	48	82	77	6	FXR510Ø15.000H7MG1M-HP145	30570741
16,000	16	150	25	48	102	97	6	FXR510Ø16.000H7MG1M-HP145	30570742
17,000	18	150	25	48	102	97	8	FXR510Ø17.000H7MG1M-HP145	30570743
18,000	18	150	25	48	102	97	8	FXR510Ø18.000H7MG1M-HP145	30570744
19,000	20	150	25	50	100	95	8	FXR510Ø19.000H7MG1M-HP145	30570745

FXR510 | Fixed design, left-hand fluted, for through bore

Configurable features

**Bore diameter tolerance \geq IT6:**

- Diameter in increments of 0.001 mm freely selectable
- Can be ordered in tolerance \geq IT6

**Specification:**

FXR510Ø[diameter][tolerance]MG1M-HP145

G variants:

- Diameter in increments of 0.001 mm freely selectable
- Can be ordered from tolerances $\geq 4 \mu\text{m}$ (G variant, see page 435)

G variant specification:

FXR510GØ[diameter][tolerance]MG1M-HP145

Dimensions of configurable series IT6

d_1	d_2	l_1	l_2	l_3	l_4	l_5	z
2,800 - 3,700	4	65	12	28	37	34	4
3,701 - 4,700	6	75	12	36	39	34	4
4,701 - 6,200	6	75	12	36	39	35	4
6,201 - 7,200	8	100	16	36	64	59	6
7,201 - 8,200	8	100	16	36	64	60	6
8,201 - 9,200	10	100	20	40	60	55	6
9,201 - 10,200	10	120	20	40	80	76	6
10,201 - 11,200	12	120	20	45	75	70	6
11,201 - 12,200	12	120	20	45	75	71	6
12,201 - 14,200	14	130	22	45	85	80	6
14,201 - 15,200	16	130	22	48	82	77	6
15,201 - 16,200	16	150	25	48	102	97	6
16,201 - 18,200	18	150	25	48	102	97	8
18,201 - 20,200	20	150	25	50	100	95	8

IT6 tolerance example:

FXR510Ø16.350H6MG1M-HP145

Bore diameter $d_1 = 16.350 \text{ H6}$ **G variant example:**

FXR510GØ16.350-4MG1M-HP145

Special tool diameter $d_1 = 16.350 - 4 \mu\text{m}$

FixReam

Fixed design, straight fluted, for blind bore FXR505

Design:

Reamer diameter: 2.800 - 20.200 mm
 Lead: MV0A
 Cutting material: HP145 Carbide
 PVD-coated

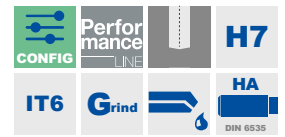
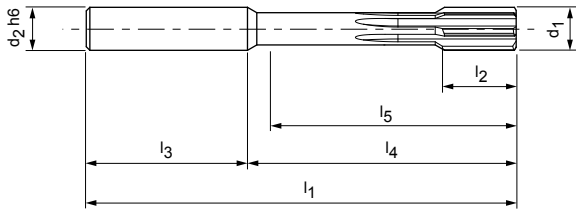

Preferred series in H7

d ₁ H7	Dimensions						z	Specification	Order no.
	d ₂ h6	l ₁	l ₂	l ₃	l ₄	l ₅			
4,000	6	75	12	36	39	34	4	FXR505Ø4.000H7MV0A-HP145	30570747
5,000	6	75	12	36	39	34	4	FXR505Ø5.000H7MV0A-HP145	30570749
6,000	6	75	12	36	39	34	4	FXR505Ø6.000H7MV0A-HP145	30570751
7,000	8	100	16	36	64	58	6	FXR505Ø7.000H7MV0A-HP145	30570753
8,000	8	100	16	36	64	58	6	FXR505Ø8.000H7MV0A-HP145	30570755
9,000	10	100	20	40	60	54	6	FXR505Ø9.000H7MV0A-HP145	30570757
10,000	10	120	20	40	80	74	6	FXR505Ø10.000H7MV0A-HP145	30570759
11,000	12	120	20	45	75	68	6	FXR505Ø11.000H7MV0A-HP145	30570761
12,000	12	120	20	45	75	68	6	FXR505Ø12.000H7MV0A-HP145	30570763
13,000	14	130	22	45	85	78	6	FXR505Ø13.000H7MV0A-HP145	30570764
14,000	14	130	22	45	85	78	6	FXR505Ø14.000H7MV0A-HP145	30570765
15,000	16	130	22	48	82	75	6	FXR505Ø15.000H7MV0A-HP145	30570766
16,000	16	150	25	48	102	95	6	FXR505Ø16.000H7MV0A-HP145	30570767
17,000	18	150	25	48	102	95	6	FXR505Ø17.000H7MV0A-HP145	30570768
18,000	18	150	25	48	102	95	6	FXR505Ø18.000H7MV0A-HP145	30570769
19,000	20	150	25	50	100	92	6	FXR505Ø19.000H7MV0A-HP145	30570770

FXR505 | Fixed design, straight fluted, for blind bore

Configurable features

**Bore diameter tolerance \geq IT6:**

- Diameter in increments of 0.001 mm freely selectable
- Can be ordered in tolerance \geq IT6

**Specification:**

FXR505Ø[diameter][tolerance]MV0A-HP145

G variants:

- Diameter in increments of 0.001 mm freely selectable
- Can be ordered from tolerances $\geq 4 \mu\text{m}$ (G variant, see page 435)

G variant specification:

FXR505GØ[diameter][tolerance]MV0A-HP145

Dimensions of configurable series IT6

d_1	d_2	l_1	l_2	l_3	l_4	l_5	z
2,800 - 3,350	4	65	12	37	28	33	4
3,351 - 3,700	4	65	12	28	37	33	4
3,701 - 6,200	6	75	12	36	39	34	4
6,201 - 8,200	8	100	16	36	64	58	6
8,201 - 9,200	10	100	20	40	60	54	6
9,201 - 10,200	10	120	20	40	80	74	6
10,201 - 12,200	12	120	20	45	75	68	6
12,201 - 14,200	14	130	22	45	85	78	6
14,201 - 15,200	16	130	22	48	82	75	6
15,201 - 16,200	16	150	25	48	102	95	6
16,201 - 18,200	18	150	25	48	102	95	6
18,201 - 20,200	20	150	25	50	100	92	6

IT6 tolerance example:

FXR505Ø16.350H6MV0A-HP145

Bore diameter $d_1 = 16.350 \text{ H6}$ **G variant example:**

FXR505GØ16.350-4MV0A-HP145

Special tool diameter $d_1 = 16.350 -4 \mu\text{m}$

Cutting data recommendations for FixReam FXR

Feed and cutting speed

FXR510 | FXR505

Cutting material: HP145 | Lead: MG1M | MVOA

MMG*		Workpiece material	Strength/ hardness [N/mm ²] [HRC]	Cutting speed v _c (m/min)			
				Internal cooling	External cooling	MQL	
P	P1	P1.1	Structural, machining, case hardened and tempering steels, unalloyed	< 700	180	90	150
		P1.2	Structural, machining, case hardened and tempering steels, unalloyed	< 1,200	140	70	115
	P2	P2.1	Nitriding, hardening and tempering steels, alloyed	< 900	180	90	150
		P2.2	Nitriding, hardening and tempering steels, alloyed	< 1,400	140	70	115
	P3	P3.1	Tool, bearing, spring and high-speed steels**	< 800	180	90	150
		P3.2	Tool, bearing, spring and high-speed steels**	< 1,000	140	70	110
		P3.3	Tool, bearing, spring and high-speed steels**	< 1,500	120	60	90
	P5	P5.1	Cast steel		140	75	100
K	K1	K1.1	Cast iron with lamellar graphite (grey cast iron), GJL	< 300	120	100	100
		K2.1	Cast iron with spheroidal graphite, GJS	< 500	150	105	130
	K2	K2.2	Cast iron with spheroidal graphite, GJS	≤ 800	120	85	98
		K2.3	Cast iron with spheroidal graphite, GJS	> 800	90	55	70
	K3	K3.1	Cast iron with vermicular graphite, GJV; malleable cast iron, GJM	< 500	90	55	70
		K3.2	Cast iron with vermicular graphite, GJV; malleable cast iron, GJM	> 500	90	55	70

* MAPAL Machining Groups

** If the alloy parts Cr, Mo, Ni, V, W in total > 8%, then select the next highest MAPAL machining group.

	Feed f_z (mm/U) with drill diameter						
	z 4	z 4	z 6	z 6	z 6	z 6	z 8
	< 5.000	> 5.000 - 6.200	> 6.200 - 8.000	> 8.000 - 12.000	> 12.000 - 16.000	> 16.000 - 16.200	> 16.200 - 20.200
	0.050	0.080	0.080	0.140	0.180	0.180	0.190
	0.050	0.080	0.080	0.140	0.180	0.180	0.190
	0.050	0.080	0.080	0.140	0.180	0.180	0.190
	0.050	0.080	0.080	0.140	0.180	0.180	0.190
	0.050	0.080	0.080	0.140	0.180	0.180	0.190
	0.050	0.080	0.080	0.140	0.180	0.180	0.190
	0.050	0.080	0.080	0.140	0.180	0.180	0.190
	0.050	0.080	0.080	0.140	0.180	0.180	0.190
	0.080	0.100	0.100	0.170	0.220	0.220	0.230
	0.080	0.100	0.100	0.170	0.220	0.220	0.230
	0.080	0.100	0.100	0.170	0.220	0.220	0.230
	0.080	0.100	0.100	0.170	0.220	0.220	0.230
	0.080	0.100	0.100	0.170	0.220	0.220	0.230
	0.080	0.100	0.100	0.170	0.220	0.220	0.230

The specified cutting data are guide values.

The optimum data for the respective machining task should be determined during the test or machining.

CLAMPING

Hydraulic, thermal and mechanical chucks for reliable tool clamping and optimum machining results. Extensions, reducers and adapters enhance the possibilities.



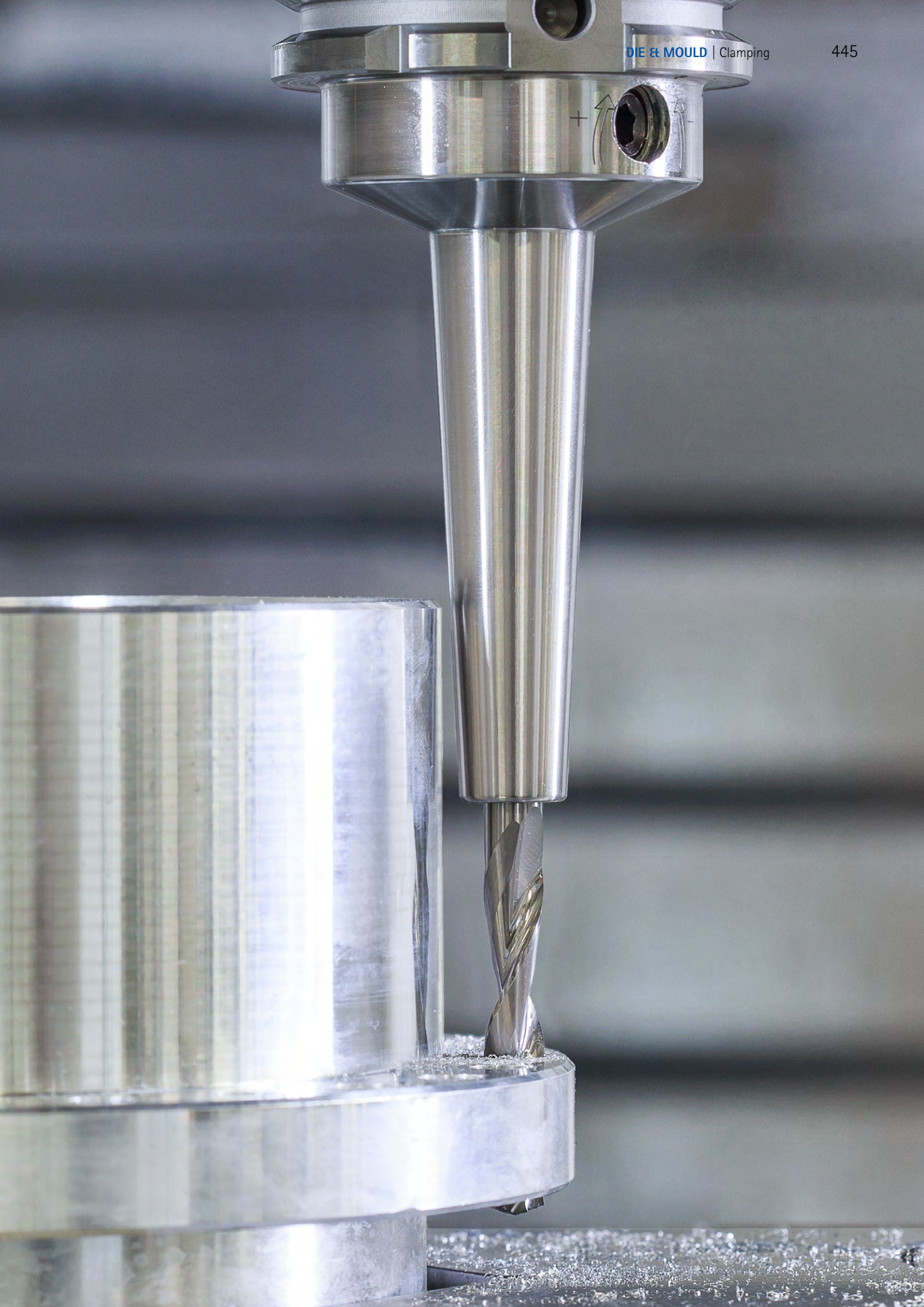

PRODUCT OVERVIEW

Clamping

MAPAL's clamping technology range guarantees performance and process reliability – as well as radial run-out and changeover accuracy – in every application. Manufactured using the most modern technologies, our specialists are continuously developing our chucks further.

The standard range covers the requirements and circumstances of customers with a large variety of systems: from hydraulic expansion and shrink chucks to mechanical clamping systems for HB shanks and adapters.

Reliable tool clamping and optimal milling results with indexable inserts are achieved by the milling cutter arbors and milling head holders. For quiet and stable machining, especially when using tools with long projections, milling cutter arbors with integrated vibration dampening are available.



Hydraulic clamping technology:

- High level of torque transmission
- Tool change in seconds without peripheral devices
- Extended tool life due to maximum radial run-out and repetition accuracy
- High flexibility when using reducing sleeves







Shrinking technology:

- High level of torque transmission and radial rigidity
- Long tool life through the use of high-temperature tool steel



Mechanical tool clamping technology:

- Simpler construction
- Easy handling
- High flexibility

Hydraulic clamping technology	Shrinking technology	Mechanical tool clamping technology	
			
<p>UNIQ Chuck</p> <p>Both hydraulic chuck series – UNIQ Mill Chuck and UNIQ DReaM Chuck – clearly combine the performance promise of quality and function in their new design. This is achieved through an optimal interplay of geometric and functional properties.</p> <ul style="list-style-type: none"> - UNIQ Mill Chuck: Temperature resistant up to 80 °C even with very long milling cycles (over 240 minutes) - UNIQ DReaM Chuck: Hydraulic chuck with the original dimensions of a shrink chuck (DIN contour with 4.5°) 	<p>HighTorque Chuck – HTC</p> <p>The HighTorque-Chuck hydraulic chuck impresses with its high level of torque transmission, its ideal damping properties, the outstanding rigidity of the entire system and a radial run-out accuracy of < 3 µm.</p> <ul style="list-style-type: none"> - 3° slim design with a back taper of three degrees to avoid tool restrictions - Short heavy design with resealable cooling channel bores and optimum damping properties for a long tool life 	<p>ThermoChuck – MTC</p> <p>With the ThermoChuck shrink chuck, tools for almost all milling operations can be clamped precisely. The high level of torque transmission and radial rigidity sets this chuck apart from the rest.</p> <ul style="list-style-type: none"> - Long tool life through the use of high-temperature-resistant tool steel - Wide range of possible combinations of shrink chucks and extensions - Precision balanced as standard - MQL-suitable - With and without axial tool length adjustment 	<p>Mill Chuck, HB</p> <p>The Mill Chuck is an impressive option with strong clamping ability, easy handling and a very good radial run-out.</p> <ul style="list-style-type: none"> - Easy to handle thanks to a differential screw - Maximum economic efficiency and precision - Axial tool positioning can be defined using spring system - Decentralised coolant outlets for maximum process reliability
<p>Page 452</p>	<p>Page 464</p>	<p>Page 474</p>	<p>Page 494</p>



Mechanical tool clamping technology

Adapter



Precision-DrillChuck - MPC

MAPAL's Precision-DrillChuck convinces with its simple design and easy, straight-forward handling. The clamping is reliably guaranteed independent of the direction of rotation, even at high spindle speeds.

- Simple construction, straightforward to handle
- Safe clamping independent of direction of rotation
- High degree of spindle speed strength
- Modular design allows drill chuck heads to be used with all tool connections



Milling cutter arbor - MDA / MCA

- **Vibration damped (MDA):** System for vibration dampening in tools with long projections directly in the tool shank. Adapted to the rigidity of all common machine types. Smooth, stable running despite long projections delivers better surface qualities.
- **Milling cutter arbor (MCA) with enlarged face connection:** Ideally suited for roughing and pre-finishing operations in large diameter ranges. High flexibility through different lengths. Highest stability guaranteed by avoiding unnecessary connections.



MFS milling head holder

The screw-in holders with a metric thread ensure maximum stability and rigidity through the exact interaction between the taper and face connection.

- Clamping screw-in milling cutters directly into the machine is simple and quick, ensuring shorter set-up times and lower tool costs
- Universally deployable for roughing and finishing operations
- Highly precise radial run-out accuracy due to μm -precise manufacturing of tightening thread and taper face section
- Highest stability guaranteed by avoiding unnecessary connections



Extensions

- Wide range of options for modular tool systems
- Tool extensions for thermal expanding chucks

Product ID codes

Chuck specification



Type

HTC	HighTorque Chuck
MTC	Shrink chuck (ThermoChuck)
MWC	Chuck for shank form HB
MCA	Milling cutter arbor
MDA	Milling cutter arbor, vibration-dampened
MPC	Precision drill chuck (Precision-DrillChuck)

Locating shank

HSK-A	Hollow shank taper Form A
HSK-E	Hollow shank taper Form E
ZYL	Cylindrical shank
Steep taper	Taper shank in form A according to ISO
BT	Taper shank in form J according to ISO

Specification, MFS milling head holder



Holder type

MFS	Milling head holder for metric fitting system
-----	---

Series

10	Cylindrical design
20	Conical design

Coolant supply

0	External coolant supply
1	Internal coolant supply

Design

N	Standard design
---	-----------------

MFS connection size

M08	Metric ISO M8 thread (example)
-----	--------------------------------

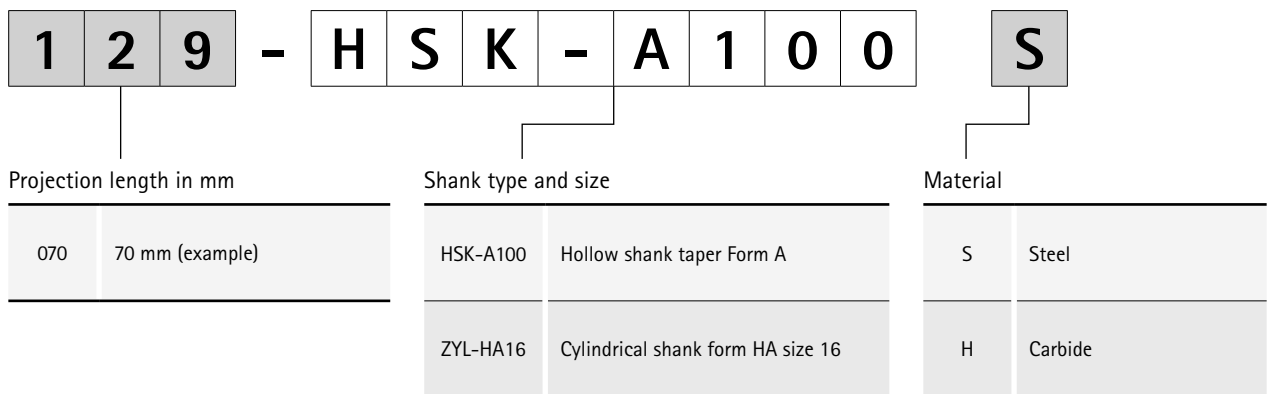
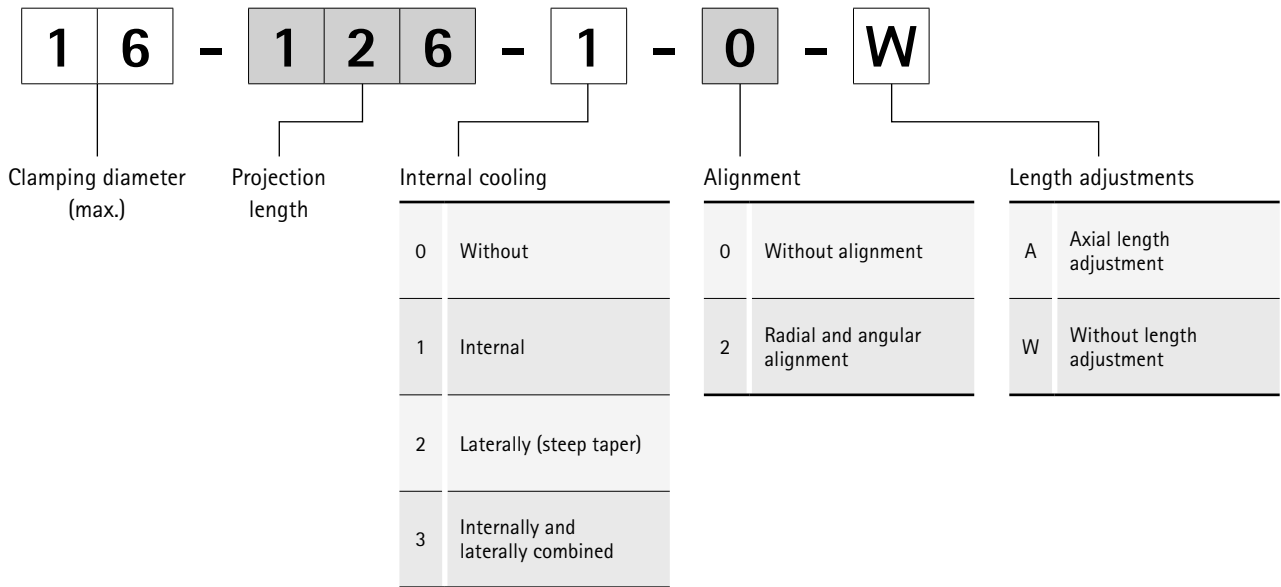



CLAMPING

Chucks

Hydraulic clamping technology

Technology – UNIQ Chuck	452
UNIQ Mill Chuck, HA	454
UNIQ DReaM Chuck, 4.5°	458
Technology – Additive hydraulic chuck	462
HighTorqueChuck HTC, slim design 3°	464
HighTorqueChuck HTC, short heavy design	471
HydroChuck MHC, ultra-short design	473

Shrinking technology

ThermoChuck MTC	474
-----------------------	-----

Mechanical tool clamping technology

Technology – Mill Chuck, HB	494
Mill Chuck MWC, HB	496
Precision-DrillChuck MPC	498
Technology – Milling cutter arbor, vibration-dampened	502
Milling cutter arbor MDA, vibration-dampened	504
Milling cutter arbor MCA, with enlarged face connection diameter	506
MFS milling head holder	510

Adapter

Extensions	515
------------------	-----

Accessories and spare parts

Coolant tubes, blind screws	517
Pull studs for steep taper adapter	518
Spare parts for milling cutter arbors	519
Reducing sleeves for hydraulic chucks	520

Technical appendix

Instructions for use	522
Technical information – Hydraulic expansion and shrinking technology	526
Standards	530



INDUSTRIAL DESIGN WITH ADDED VALUE – UNIQ® CHUCK

The newly-developed hydraulic expansion clamping system enables high machining parameters through excellent stability and accuracy. It minimises self-excited vibration so that clamped tools are not exposed to micro-vibration. This in turn leads to a reduced spindle load of up to 5 per cent, enables significantly longer tool life and guarantees optimal surface quality.

In addition, the brilliant surface which MAPAL creates using a specially developed polishing process ensures that the chucks are more resistant to dirt and corrosion. Users can safely clamp the tool in the holder with little force. This is ensured by "foolproof handling", i.e. simple and self-explanatory handling of the chucks. A lot of time is saved compared to other clamping mechanisms, especially with the UNIQ Hydro DReaM Chuck 4.5°.



Design features in detail:

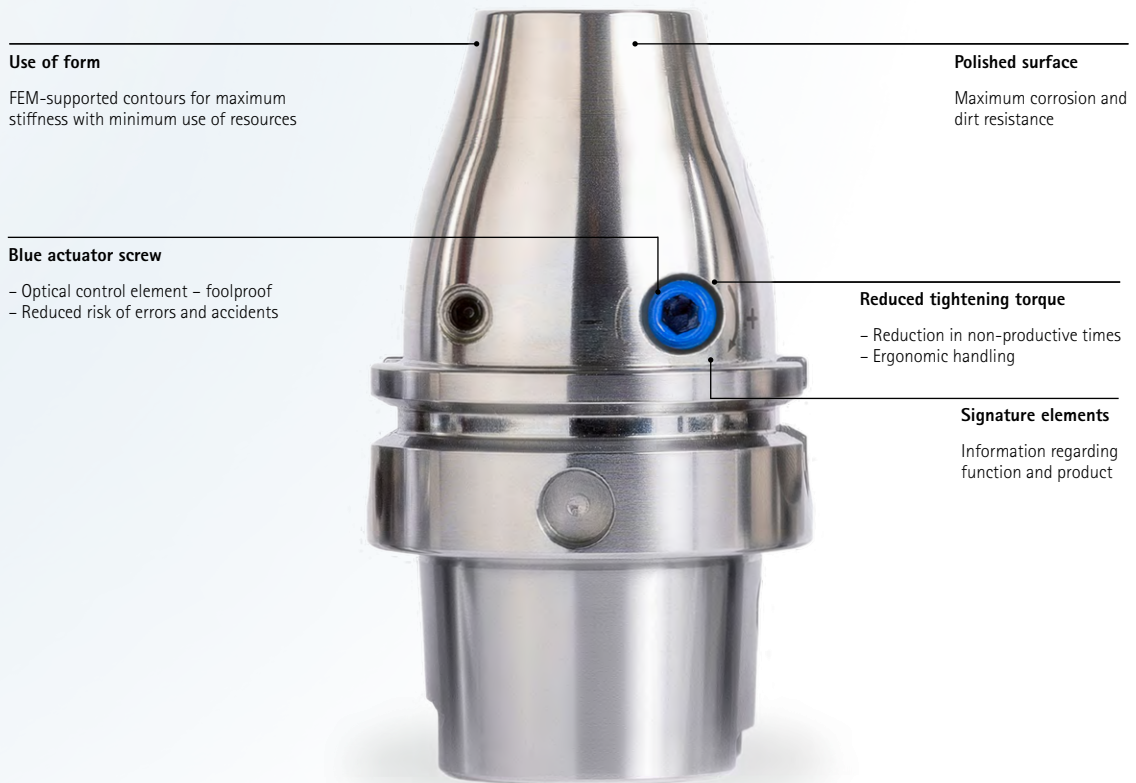

Use of form

FEM-supported contours for maximum stiffness with minimum use of resources

Polished surface

Maximum corrosion and dirt resistance

Blue actuator screw

- Optical control element - foolproof
- Reduced risk of errors and accidents

Reduced tightening torque

- Reduction in non-productive times
- Ergonomic handling

Signature elements

Information regarding function and product



Use of form | Bionic contours

- Higher stability and accuracy of the overall system
- Less displacement of the tool
- The tool cutting edge is constantly engaged
- Less weight through minimal use of resources
- Sits well in the hand when setting up the tool magazine
- Self-excited vibrations are minimised
- The tools are not exposed to micro-vibrations

Polished surfaces

- Dirt resistance (corrosion resistance) increased
- Highest balancing qualities due to compacted surfaces

Blue actuator screw | Signature elements

- Clear assignment of the operating screw and easier actuation through reduction of the tightening torque of the actuator screw by up to 70%
- Clear arrangement on the product, important functional and product information immediately available

UNIQ® Mill Chuck, HA

With axial tool length adjustment

HSK-A (hollow shank taper form A) shank according to DIN 69893-1

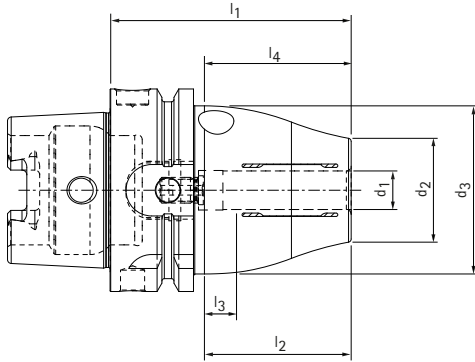

HSK-A	Dimensions							G	Torque * [Nm]	Specification	Order no.
	d ₁	d ₂	d ₃	l ₁	l ₂	l ₃	l ₄				
63	6,0	26,0	50,0	65,0	37,0	10,0	35,2	M5	22	MHC-HSK-A063-06-065-1-0-A	31270591
63	8,0	28,0	50,0	65,0	37,0	10,0	35,2	M6	47	MHC-HSK-A063-08-065-1-0-A	31270593
63	10,0	30,0	50,0	75,0	41,0	10,0	45,2	M8x1	85	MHC-HSK-A063-10-075-1-0-A	31270595
63	12,0	32,0	52,5	75,0	46,0	10,0	45,2	M8x1	130	MHC-HSK-A063-12-075-1-0-A	31229418
63	14,0	34,0	52,5	75,0	46,0	10,0	45,2	M8x1	240	MHC-HSK-A063-14-075-1-0-A	31374670
63	16,0	38,0	52,5	79,0	49,0	10,0	49,2	M8x1	350	MHC-HSK-A063-16-079-1-0-A	31270598
63	18,0	38,0	52,5	79,0	49,0	10,0	49,2	M8x1	430	MHC-HSK-A063-18-079-1-0-A	31374671
63	20,0	38,0	52,5	79,0	51,0	10,0	49,2	M8x1	520	MHC-HSK-A063-20-079-1-0-A	31229438
100	6,0	26,0	50,0	73,0	37,0	10,0	40,2	M5	22	MHC-HSK-A100-06-073-1-0-A	31345192
100	8,0	28,0	50,0	73,0	37,0	10,0	40,2	M6	47	MHC-HSK-A100-08-073-1-0-A	31345193
100	10,0	30,0	50,0	83,0	41,0	10,0	50,2	M8x1	85	MHC-HSK-A100-10-083-1-0-A	31345194
100	12,0	32,0	52,5	83,0	46,0	10,0	50,2	M8x1	130	MHC-HSK-A100-12-083-1-0-A	31345195
100	14,0	34,0	52,5	83,0	46,0	10,0	50,2	M8x1	240	MHC-HSK-A100-14-083-1-0-A	31345196
100	16,0	38,0	52,5	87,0	49,0	10,0	54,2	M8x1	350	MHC-HSK-A100-16-087-1-0-A	31345197
100	18,0	38,0	52,5	87,0	49,0	10,0	54,2	M8x1	430	MHC-HSK-A100-18-087-1-0-A	31345198
100	20,0	38,0	52,5	87,0	51,0	10,0	54,2	M8x1	520	MHC-HSK-A100-20-087-1-0-A	31345199

* Permissible transferable torque.

Dimensions in mm.

Use: For clamping tools with smooth cylindrical shanks according to DIN 1835 form A, DIN 6535 form HA as well as with recesses according to DIN 1835 form B, E and DIN 6535 form HB, HE directly and with reducing sleeve in the clamping diameter. The clamping diameter is designed for a shank tolerance of h6.

Scope of delivery: With length adjustment screw, without coolant tube.

Design: Highest tool life and production quality when using smooth cylindrical shanks according to DIN 1835 form A and DIN 6535 form HA. With a projection length of 2.5xD (max. 50 mm) radial run-out accuracy 3 µm. When using cylindrical shanks with an in-

clined clamping surface (form E and form HE), the accuracy may be impaired. Torque transmission perfectly tailored to your application.

Note: Coolant supply via central through hole. Coolant tubes, code carrier, reducing sleeve for reducing the clamping diameter (on the usage of the reducing sleeve the accuracy may be degraded) see section "Accessories, spare parts and measuring equipment". Length adjustment screws available on request.

Balancing quality: G 2.5 with 25,000 rpm in delivery status.

UNIQ® Mill Chuck, HA

With axial tool length adjustment

SK shank according to ISO 7388-1 Form AD/AF

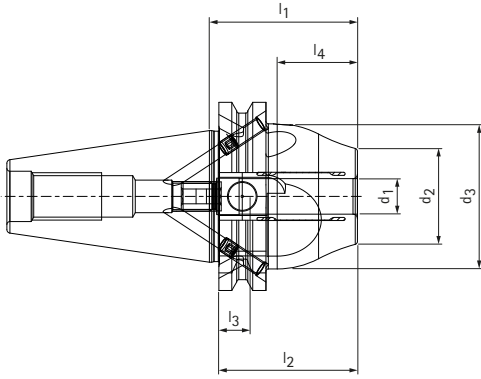

Steep taper	Dimensions							G	Torque * [Nm]	Specification	Order no.
	d ₁	d ₂	d ₃	l ₁	l ₂	l ₃	l ₄				
40	6,0	26,0	42,0	50,0	37,0	10,0	27,1	M5	22	MHC-SK040-06-050-3-0-A	31345212
40	8,0	28,0	42,0	50,0	37,0	10,0	27,1	M6	47	MHC-SK040-08-050-3-0-A	31345213
40	10,0	30,0	42,0	50,0	41,0	10,0	27,1	M8x1	85	MHC-SK040-10-050-3-0-A	31345214
40	12,0	32,0	49,0	50,0	46,0	10,0	27,1	M10x1	130	MHC-SK040-12-050-3-0-A	31345215
40	14,0	34,0	49,0	50,0	46,0	10,0	27,1	M10x1	240	MHC-SK040-14-050-3-0-A	31374686
40	16,0	38,0	49,0	64,5	49,0	10,0	41,6	M12x1	350	MHC-SK040-16-065-3-0-A	31345216
40	18,0	38,0	49,0	64,5	49,0	10,0	41,6	M12x1	430	MHC-SK040-18-065-3-0-A	31374687
40	20,0	38,0	49,0	64,5	51,0	10,0	41,6	M16x1	520	MHC-SK040-20-065-3-0-A	31345217

* Permissible transferable torque.

Dimensions in mm.

Use: For clamping tools with smooth cylindrical shanks according to DIN 1835 form A, DIN 6535 form HA as well as with recesses according to DIN 1835 form B, E and DIN 6535 form HB, HE directly and with reducing sleeve in the clamping diameter. The clamping diameter is designed for a shank tolerance of h6.

Scope of delivery: With length adjustment screw, without pull stud.

Design: Highest tool life and production quality when using smooth cylindrical shanks according to DIN 1835 form A and DIN 6535 form HA. With a projection length of 2.5xD (max. 50 mm) radial run-out accuracy 3 µm. When using cylindrical shanks with an in-

clined clamping surface (form E and form HE), the accuracy may be impaired. Torque transmission perfectly tailored to your application.

Note: Coolant supply via central through hole. Pull stud, reducing sleeves to reduce the clamping diameter (if the reducing sleeve is used, the accuracy may be impaired), see section "Accessories and spare parts". Length adjustment screws available on request.

Balancing quality: G 2.5 with 25,000 rpm in delivery status.

UNIQ® Mill Chuck, HA

With axial tool length adjustment

Shank BT according to ISO 7388-2 Form JD/JF (JIS B 6339)

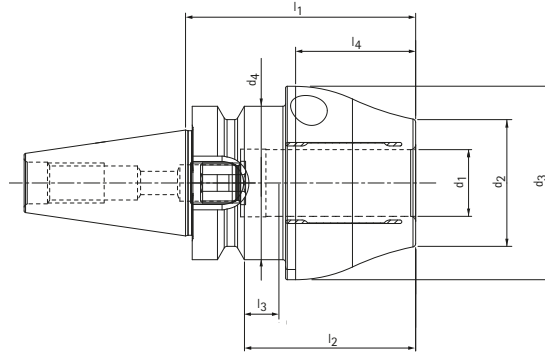
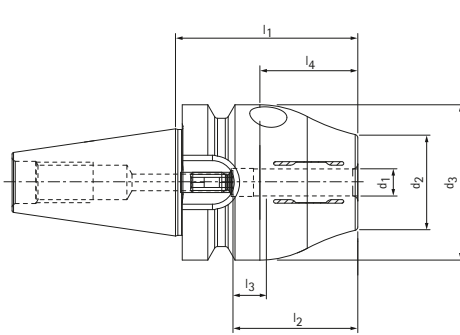

BT	Dimensions								G	Torque * [Nm]	Specification	Order no.
	d ₁	d ₂	d ₃	d ₄	l ₁	l ₂	l ₃	l ₄				
30**	6,0	26,0	46,0	-	54,0	37,0	10,0	29	M5	22	MHC-BT030-06-054-1-0-A	31280342
30**	8,0	28,0	46,0	-	54,0	37,0	10,0	29	M6	47	MHC-BT030-08-054-1-0-A	31280343
30**	10,0	30,0	50,0	46,0	54,0	41,0	10,0	23,5	M8x1	85	MHC-BT030-10-054-1-0-A	31280344
30**	12,0	32,0	50,0	46,0	54,0	46,0	10,0	23,5	M10x1	130	MHC-BT030-12-054-1-0-A	31280345
30**	14,0	38,0	52,0	46,0	54,0	46,0	10,0	21,0	M10x1	240	MHC-BT030-14-054-1-0-A	31374678
30**	16,0	38,0	55,0	46,0	69,0	49,0	10,0	38,5	M12x1	350	MHC-BT030-16-069-1-0-A	31280346
30**	18,0	38,0	55,0	46,0	69,0	49,0	10,0	36,0	M12x1	430	MHC-BT030-18-069-1-0-A	31374679
30**	20,0	38,0	58,0	46,0	69,0	51,0	10,0	38,5	M12x1	520	MHC-BT030-20-069-1-0-A	31280347

* Permissible transferable torque.

** Design: Taper shank size is not available in the JD/JF combination design.

Dimensions in mm.

Use: For clamping tools with smooth cylindrical shanks according to DIN 1835 form A, DIN 6535 form HA as well as with recesses according to DIN 1835 form B, E and DIN 6535 form HB, HE directly and with reducing sleeve in the clamping diameter. The clamping diameter is designed for a shank tolerance of h6.

Scope of delivery: With length adjustment screw, without pull stud.

Design: Highest tool life and production quality when using smooth cylindrical shanks according to DIN 1835 form A and DIN 6535 form HA. With a projection length of 2.5xD (max. 50 mm) radial run-out accuracy 3 µm. When using cylindrical shanks with an in-

clined clamping surface (form E and form HE), the accuracy may be impaired. Torque transmission perfectly tailored to your application.

Note: Coolant supply via central through hole. Pull stud, reducing sleeves to reduce the clamping diameter (if the reducing sleeve is used, the accuracy may be impaired), see section "Accessories and spare parts". Length adjustment screws available on request.

Balancing quality: G 2.5 with 25,000 rpm in delivery status.

UNIQ® Mill Chuck, HA

With axial tool length adjustment

"CAT" shank in accordance with ASME B5.50-1994

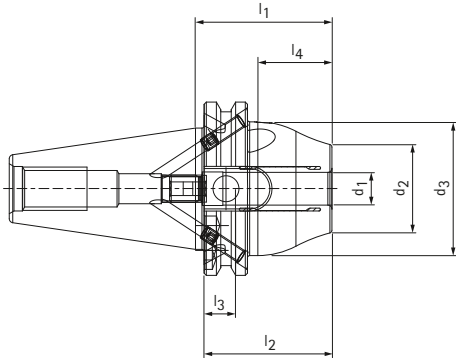

CAT	Dimensions							G	Torque * [Nm]	Specification	Order no.
	d_1	d_2	d_3	l_1	l_2	l_3	l_4				
40	6,0	26,0	42,0	50,0	37,0	10,0	27,1	M5	22	MHC-CAT040-06-050-3-0-A	31345224
40	8,0	28,0	42,0	50,0	37,0	10,0	27,1	M6	47	MHC-CAT040-08-050-3-0-A	31345225
40	10,0	30,0	42,0	50,0	41,0	10,0	27,1	M8x1	85	MHC-CAT040-10-050-3-0-A	31345226
40	12,0	32,0	49,0	50,0	46,0	10,0	27,1	M10x1	130	MHC-CAT040-12-050-3-0-A	31345227
40	14,0	32,0	49,0	50,0	46,0	10,0	27,1	M10x1	240	MHC-CAT040-14-050-3-0-A	31374694
40	16,0	38,0	49,0	64,5	49,0	10,0	41,6	M12x1	350	MHC-CAT040-16-065-3-0-A	31345228
40	18,0	38,0	49,0	64,5	49,0	10,0	41,6	M12x1	430	MHC-CAT040-18-065-3-0-A	31374695
40	20,0	38,0	49,0	64,5	51,0	10,0	41,6	M16x1	520	MHC-CAT040-20-065-3-0-A	31345229

* Permissible transferable torque.

Dimensions in mm.

Use: For clamping tools with smooth cylindrical shanks according to DIN 1835 form A, DIN 6535 form HA as well as with recesses according to DIN 1835 form B, E and DIN 6535 form HB, HE directly and with reducing sleeve in the clamping diameter. The clamping diameter is designed for a shank tolerance of h6.

Scope of delivery: With length adjustment screw, without pull stud.

Design: Highest tool life and production quality when using smooth cylindrical shanks according to DIN 1835 form A and DIN 6535 form HA. With a projection length of 2.5xD (max. 50 mm) radial run-out accuracy 3 μ m. When using cylindrical shanks with an in-

clined clamping surface (form E and form HE), the accuracy may be impaired. Torque transmission perfectly tailored to your application.

Note: Coolant supply via central through hole. Pull stud, reducing sleeves to reduce the clamping diameter (if the reducing sleeve is used, the accuracy may be impaired), see section "Accessories and spare parts". Length adjustment screws available on request.

Balancing quality: G 2.5 with 25,000 rpm in delivery status.

UNIQ® DReaM Chuck, 4.5°

With axial tool length adjustment, clamping initiation in collar HSK-A (hollow shank taper form A) shank according to DIN 69893-1

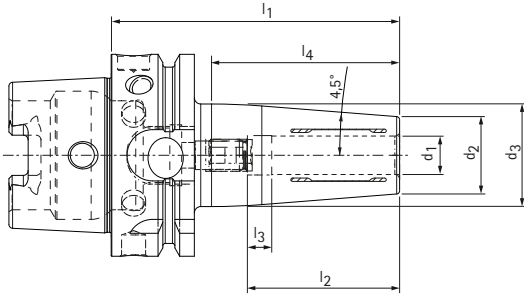

HSK-A	Dimensions							G	Torque * [Nm]	Specification	Order no.
	d ₁	d ₂	d ₃	l ₁	l ₂	l ₃	l ₄				
63	6,0	21,0	27,0	80,0	37,0	10,0	48,9	M5	18	MHC-HSK-A063-06-080-1-0-A	31270515
63	8,0	21,0	27,0	80,0	37,0	10,0	48,9	M6	35	MHC-HSK-A063-08-080-1-0-A	31270525
63	10,0	24,0	32,0	85,0	41,0	10,0	53,7	M8x1	60	MHC-HSK-A063-10-085-1-0-A	31270550
63	12,0	24,0	32,0	90,0	46,0	10,0	58,6	M10x1	90	MHC-HSK-A063-12-090-1-0-A	31229439
63	14,0	27,0	34,0	90,0	46,0	10,0	57,2	M10x1	130	MHC-HSK-A063-14-090-1-0-A	31375071
63	16,0	27,0	34,0	95,0	49,0	10,0	63,1	M12x1	200	MHC-HSK-A063-16-095-1-0-A	31270555
63	18,0	33,0	42,0	95,0	49,0	10,0	63,0	M12x1	250	MHC-HSK-A063-18-095-1-0-A	31375072
63	20,0	33,0	42,0	100,0	51,0	10,0	68,9	M16x1	330	MHC-HSK-A063-20-100-1-0-A	31229440
100	6,0	21,0	27,0	85,0	37,0	10,0	38,7	M5	18	MHC-HSK-A100-06-085-1-0-A	31344789
100	8,0	21,0	27,0	85,0	37,0	10,0	38,7	M6	35	MHC-HSK-A100-08-085-1-0-A	31344860
100	10,0	24,0	32,0	90,0	41,0	10,0	53,7	M8x1	60	MHC-HSK-A100-10-090-1-0-A	31344862
100	12,0	24,0	32,0	95,0	46,0	10,0	58,6	M10x1	90	MHC-HSK-A100-12-095-1-0-A	31344863
100	14,0	27,0	34,0	95,0	46,0	10,0	57,2	M10x1	130	MHC-HSK-A100-14-095-1-0-A	31344864
100	16,0	27,0	34,0	100,0	49,0	10,0	63,1	M12x1	200	MHC-HSK-A100-16-100-1-0-A	31344865
100	18,0	33,0	42,0	100,0	49,0	10,0	63,0	M12x1	250	MHC-HSK-A100-18-100-1-0-A	31344866
100	20,0	33,0	42,0	105,0	51,0	10,0	68,9	M16x1	330	MHC-HSK-A100-20-105-1-0-A	31344867

* Permissible transferable torque.

Dimensions in mm.

Use: For clamping tools with smooth cylindrical shanks according to DIN 1835 form A, DIN 6535 form HA as well as with recesses according to DIN 1835 form B, E and DIN 6535 form HB, HE directly and with reducing sleeve in the clamping diameter. The clamping diameter is designed for a shank tolerance of h6.

Scope of delivery: With length adjustment screw, without coolant tube.

Design: Highest tool life and production quality when using smooth cylindrical shanks according to DIN 1835 form A and DIN 6535 form HA. With a projection length of 2.5xD (max. 50 mm) radial run-out accuracy 3 µm. When using cylindrical shanks with an in-

clined clamping surface (form E and form HE), the accuracy may be impaired. Torque transmission perfectly tailored to your application.

Note: Coolant supply via central through hole. Coolant tubes, code carrier, reducing sleeve for reducing the clamping diameter (on the usage of the reducing sleeve the accuracy may be degraded) see section "Accessories, spare parts and measuring equipment". Length adjustment screws available on request.

Balancing quality: G 2.5 with 25,000 rpm in delivery status.

UNIQ® DReaM Chuck, 4.5°

With axial tool length adjustment, clamping initiation in collar SK shank according to ISO 7388-1 Form AD/AF

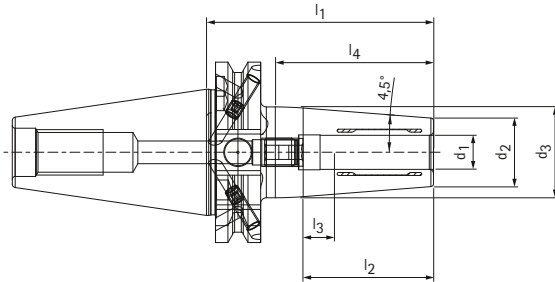

Steep taper	Dimensions							G	Torque * [Nm]	Specification	Order no.
	d ₁	d ₂	d ₃	l ₁	l ₂	l ₃	l ₄				
40	6,0	21,0	27,0	80,0	37,0	10,0	55,7	M5	18	MHC-SK040-06-080-3-0-A	31344880
40	8,0	21,0	27,0	80,0	37,0	10,0	55,7	M6	35	MHC-SK040-08-080-3-0-A	31344881
40	10,0	24,0	32,0	80,0	41,0	10,0	55,7	M8x1	60	MHC-SK040-10-080-3-0-A	31344882
40	12,0	24,0	32,0	80,0	46,0	10,0	55,7	M10x1	90	MHC-SK040-12-080-3-0-A	31344883
40	14,0	27,0	34,0	80,0	46,0	10,0	55,8	M10x1	130	MHC-SK040-14-080-3-0-A	31375087
40	16,0	27,0	34,0	80,0	49,0	10,0	55,8	M12x1	200	MHC-SK040-16-080-3-0-A	31344884
40	18,0	33,0	42,0	80,0	49,0	10,0	57,2	M12x1	250	MHC-SK040-18-080-3-0-A	31375088
40	20,0	33,0	42,0	80,0	51,0	10,0	57,2	M16x1	330	MHC-SK040-20-080-3-0-A	31344885

* Permissible transferable torque.

Dimensions in mm.

Use: For clamping tools with smooth cylindrical shanks according to DIN 1835 form A, DIN 6535 form HA as well as with recesses according to DIN 1835 form B, E and DIN 6535 form HB, HE directly and with reducing sleeve in the clamping diameter. The clamping diameter is designed for a shank tolerance of h6.

Scope of delivery: With length adjustment screw, without pull stud.

Design: Highest tool life and production quality when using smooth cylindrical shanks according to DIN 1835 form A and DIN 6535 form HA. With a projection length of 2.5xD (max. 50 mm) radial run-out accuracy 3 µm. When using cylindrical shanks with an in-

clined clamping surface (form E and form HE), the accuracy may be impaired. Torque transmission perfectly tailored to your application.

Note: Coolant supply via central through hole. Pull stud, reducing sleeves to reduce the clamping diameter (if the reducing sleeve is used, the accuracy may be impaired), see section "Accessories and spare parts". Length adjustment screws available on request.

Balancing quality: G 2.5 with 25,000 rpm in delivery status.

UNIQ® DReaM Chuck, 4.5°

With axial tool length adjustment, clamping initiation in collar
Shank BT according to ISO 7388-2 Form JD/JF (JIS B 6339)

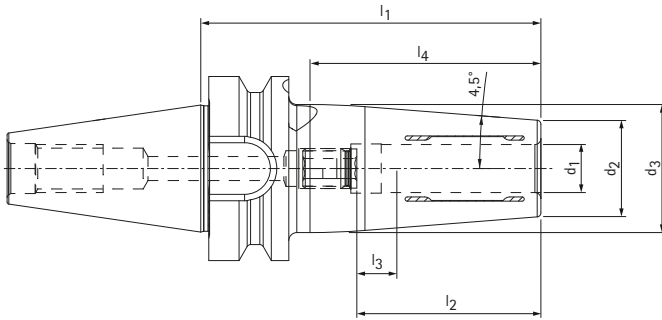

BT	Dimensions							G	Torque * [Nm]	Specification	Order no.
	d ₁	d ₂	d ₃	l ₁	l ₂	l ₃	l ₄				
30**	6,0	21,0	27,0	85,0	37,0	10,0	57,7	M5	18	MHC-BT030-06-085-1-0-A	31280360
30**	8,0	21,0	27,0	85,0	37,0	10,0	57,7	M6	35	MHC-BT030-08-085-1-0-A	31280361
30**	10,0	24,0	32,0	85,0	41,0	10,0	57,7	M8x1	60	MHC-BT030-10-085-1-0-A	31280362
30**	12,0	24,0	32,0	85,0	46,0	10,0	57,7	M10x1	90	MHC-BT030-12-085-1-0-A	31280365
30**	14,0	27,0	34,0	85,0	46,0	10,0	57,2	M10x1	130	MHC-BT030-14-085-1-0-A	31375079
30**	16,0	27,0	34,0	85,0	49,0	10,0	57,2	M10x1	200	MHC-BT030-16-085-1-0-A	31280366
30**	18,0	33,0	42,0	85,0	49,0	10,0	57,5	M12x1	250	MHC-BT030-18-085-1-0-A	31375080
30**	20,0	33,0	42,0	85,0	51,0	10,0	57,5	M10x1	330	MHC-BT030-20-085-1-0-A	31280367

* Permissible transferable torque.

** Design: Taper shank size is not available in the JD/JF combination design.

Dimensions in mm.

Use: For clamping tools with smooth cylindrical shanks according to DIN 1835 form A, DIN 6535 form HA as well as with recesses according to DIN 1835 form B, E and DIN 6535 form HB, HE directly and with reducing sleeve in the clamping diameter. The clamping diameter is designed for a shank tolerance of h6.

Scope of delivery: With length adjustment screw, without pull stud.

Design: Highest tool life and production quality when using smooth cylindrical shanks according to DIN 1835 form A and DIN 6535 form HA. With a projection length of 2.5xD (max. 50 mm) radial run-out accuracy 3 µm. When using cylindrical shanks with an in-

clined clamping surface (form E and form HE), the accuracy may be impaired. Torque transmission perfectly tailored to your application.

Note: Coolant supply via central through hole. Pull stud, reducing sleeves to reduce the clamping diameter. (If the reducing sleeve is used, the accuracy may be impaired), see section "Accessories and spare parts". Length adjustment screws available on request.

Balancing quality: G 2.5 with 25,000 rpm in delivery status.

UNIQ® DReaM Chuck, 4.5°

With axial tool length adjustment, clamping initiation in collar "CAT" shank in accordance with ASME B5.50-1994

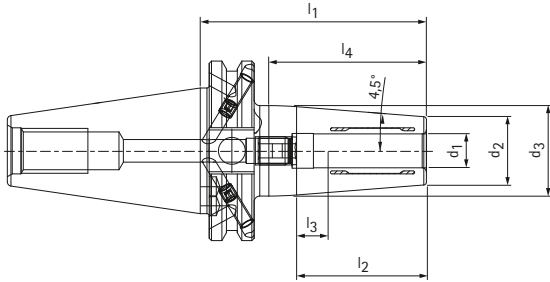

Steep taper	Dimensions							G	Torque * [Nm]	Specification	Order no.
	d ₁	d ₂	d ₃	l ₁	l ₂	l ₃	l ₄				
40	6,0	21,0	27,0	80,0	37,0	10,0	55,7	M5	18	MHC-CAT040-06-080-3-0-A	31344892
40	8,0	21,0	27,0	80,0	37,0	10,0	55,7	M6	35	MHC-CAT040-08-080-3-0-A	31344893
40	10,0	24,0	32,0	80,0	41,0	10,0	55,7	M8x1	60	MHC-CAT040-10-080-3-0-A	31344894
40	12,0	24,0	32,0	80,0	46,0	10,0	55,7	M10x1	90	MHC-CAT040-12-080-3-0-A	31344895
40	14,0	27,0	34,0	80,0	46,0	10,0	55,8	M10x1	130	MHC-CAT040-14-080-3-0-A	31375095
40	16,0	27,0	34,0	80,0	49,0	10,0	55,8	M12x1	200	MHC-CAT040-16-080-3-0-A	31344896
40	18,0	33,0	42,0	80,0	49,0	10,0	57,2	M12x1	250	MHC-CAT040-18-080-3-0-A	31375096
40	20,0	33,0	42,0	80,0	51,0	10,0	57,2	M16x1	330	MHC-CAT040-20-080-3-0-A	31344897

* Permissible transferable torque.

Dimensions in mm.

Use: For clamping tools with smooth cylindrical shanks according to DIN 1835 form A, DIN 6535 form HA as well as with recesses according to DIN 1835 form B, E and DIN 6535 form HB, HE directly and with reducing sleeve in the clamping diameter. The clamping diameter is designed for a shank tolerance of h6.

Scope of delivery: With length adjustment screw, without pull stud.

Design: Highest tool life and production quality when using smooth cylindrical shanks according to DIN 1835 form A and DIN 6535 form HA. With a projection length of 2.5xD (max. 50 mm) radial run-out accuracy 3 µm. When using cylindrical shanks with an in-

clined clamping surface (form E and form HE), the accuracy may be impaired. Torque transmission perfectly tailored to your application.

Note: Coolant supply via central through hole. Pull stud, reducing sleeves to reduce the clamping diameter (if the reducing sleeve is used, the accuracy may be impaired), see section "Accessories and spare parts". Length adjustment screws available on request.

Balancing quality: G 2.5 with 25,000 rpm in delivery status.

ADDITIVE MANUFACTURING PUSHES THE LIMITS OF HYDRAULIC EXPANSION TECHNOLOGY

Accuracy, process reliability, flexibility and easy handling are essential requirements for chucks. Of the available solutions, hydraulic chucks give the greatest consideration to the factor of accuracy. Up until now, however, the brazed connection in hydraulic chucks has been a limiting factor for thermal stability and torque transmission. Additive manufacturing pushes this limit by producing the chuck "from a single cast" and making the technology usable for a much wider range of applications.

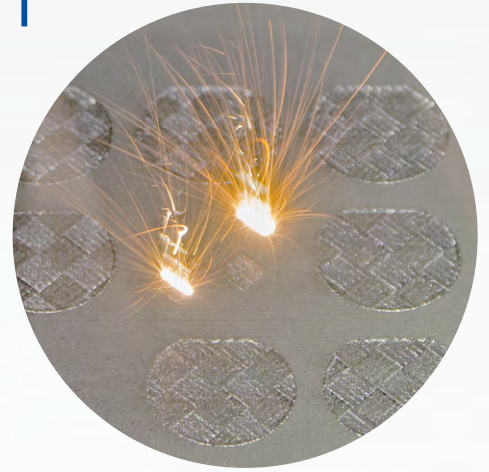

Advantages of additive-manufactured hydraulic expansion technology in detail

- 1 Optimal radial run-out as the clamping range is located close to the chuck tip
- 2 High torque transmission and thermal stability
- 3 Back taper of 3° in the outer contour enables machining in the contour-critical area
- 4 All-in-one casting – no brazed connection between sleeve and tool body
- 5 High flexural strength despite slender design
- 6 Quick and simple clamping thanks to hexagon head screw

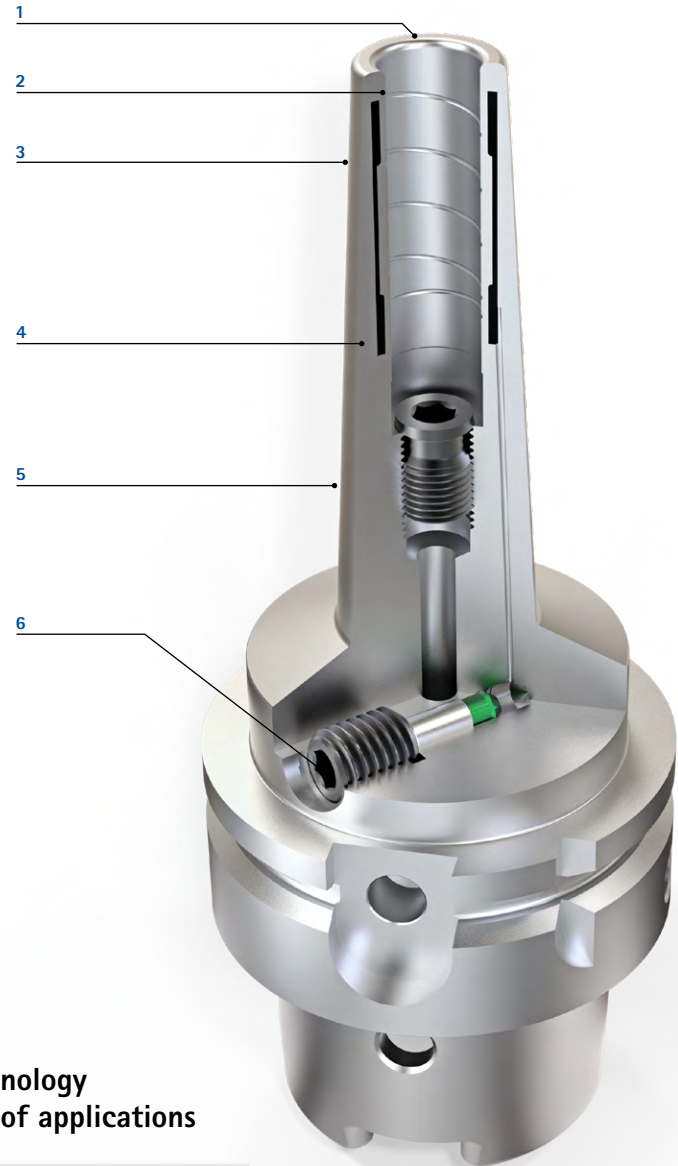

Additive-manufactured hydraulic expansion technology with minimum tool restrictions for a wide range of applications

ADVANTAGES

- Wide range of applications including in the mould sector and automotive and aerospace field
- Machining in the contour-critical area
- Reliable clamping even at temperatures of up to 120 °C as there is no brazed connection between sleeve and tool body
- Optimum radial run-out accuracy of 3 µm with a projection length of 2.5xD
- Better surface finishes with longer tool life
- Shorter set-up times and lower tool costs
- No peripheral devices necessary

PERFORMANCE FEATURES

- Slim contour with back taper of 3 degrees
- High torque transmission and bending resistance
- Simple and fast clamping directly in the machine
- Balancing quality of G 2.5 at 25,000 rpm
- ø area 3–32 mm
- Available with hollow shank taper and steep taper shanks
- RFID optionally available

HighTorque Chuck HTC

With axial tool length adjustment

HSK-A (hollow shank taper form A) shank according to DIN 69893-1

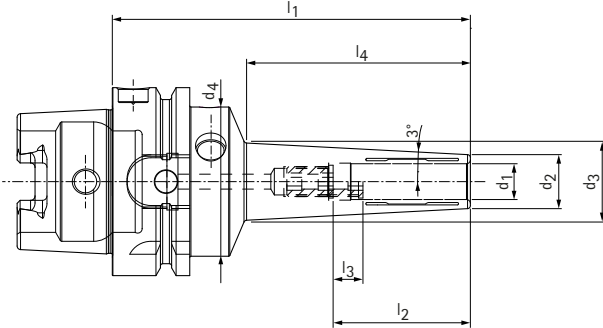

3° slim design

HSK-A	Dimensions								G	Specification	Order no.
	d ₁	d ₂	d ₃	d ₄	l ₁	l ₂	l ₃	l ₄			
40	3,0	9,0	13,8	33,5	85,0	28,0	16,0	45,0	M2,5	HTC-HSK-A040-03-85-1-0-A	30817979
40	4,0	10,0	14,8	33,5	85,0	28,0	12,0	45,0	M2,5	HTC-HSK-A040-04-85-1-0-A	30817980
40	5,0	11,0	15,8	33,5	85,0	28,0	8,0	45,0	M2,5	HTC-HSK-A040-05-85-1-0-A	30817981
40	6,0	12,0	16,9	33,5	85,0	37,0	10,0	46,0	M5	HTC-HSK-A040-06-85-1-0-A	30817982
40	8,0	14,0	18,9	33,5	85,0	37,0	10,0	46,0	M6	HTC-HSK-A040-08-85-1-0-A	30817983
40	10,0	16,0	21,0	33,5	85,0	41,0	10,0	47,0	M5	HTC-HSK-A040-10-85-1-0-A	30817984
40	12,0	18,0	23,0	33,5	85,0	46,0	10,0	47,0	M5	HTC-HSK-A040-12-85-1-0-A	30817985
63	3,0	9,0	16,7	50,0	120,0	28,0	16,0	73,0	M2,5	HTC-HSK-A063-03-120-1-0-A	30639848
63	4,0	10,0	17,7	50,0	120,0	28,0	12,0	73,0	M2,5	HTC-HSK-A063-04-120-1-0-A	30702807
63	5,0	11,0	18,7	50,0	120,0	28,0	8,0	73,0	M2,5	HTC-HSK-A063-05-120-1-0-A	30702808
63	6,0	12,0	19,8	50,0	120,0	37,0	10,0	74,0	M5	HTC-HSK-A063-06-120-1-0-A	30639849
63	7,0	13,0	20,8	50,0	120,0	37,0	10,0	74,0	M5	HTC-HSK-A063-07-120-1-0-A	30856736
63	8,0	14,0	21,8	50,0	120,0	37,0	10,0	74,0	M6	HTC-HSK-A063-08-120-1-0-A	30639851
63	9,0	15,0	22,8	50,0	120,0	37,0	10,0	74,0	M6	HTC-HSK-A063-09-120-1-0-A	30856737
63	10,0	16,0	23,8	50,0	120,0	41,0	10,0	74,0	M8x1	HTC-HSK-A063-10-120-1-0-A	30639852
63	11,0	17,0	24,8	50,0	120,0	41,0	10,0	74,0	M8x1	HTC-HSK-A063-11-120-1-0-A	30856738
63	12,0	18,0	25,9	50,0	120,0	46,0	10,0	75,0	M10x1	HTC-HSK-A063-12-120-1-0-A	30639853
63	13,0	20,0	27,9	50,0	120,0	46,0	10,0	75,0	M10x1	HTC-HSK-A063-13-120-1-0-A	30856739
63	14,0	22,0	29,5	50,0	120,0	46,0	10,0	71,0	M10x1	HTC-HSK-A063-14-120-1-0-A	30782686
63	16,0	24,0	31,5	50,0	120,0	49,0	10,0	71,5	M12x1	HTC-HSK-A063-16-120-1-0-A	30699883
63	18,0	26,0	33,6	50,0	120,0	49,0	10,0	72,0	M12x1	HTC-HSK-A063-18-120-1-0-A	30699886
63	20,0	28,0	35,6	50,0	120,0	51,0	10,0	72,0	M16x1	HTC-HSK-A063-20-120-1-0-A	30699888
100	3,0	9,0	16,4	50,0	120,0	28,0	16,0	70,0	M2,5	HTC-HSK-A100-03-120-1-0-A	30856740
100	4,0	10,0	17,4	50,0	120,0	28,0	12,0	70,0	M2,5	HTC-HSK-A100-04-120-1-0-A	30856741
100	5,0	11,0	18,4	50,0	120,0	28,0	8,0	70,0	M2,5	HTC-HSK-A100-05-120-1-0-A	30856742
100	6,0	12,0	19,4	50,0	120,0	37,0	10,0	70,0	M5	HTC-HSK-A100-06-120-1-0-A	30856743
100	8,0	14,0	21,5	50,0	120,0	37,0	10,0	71,0	M6	HTC-HSK-A100-08-120-1-0-A	30856745
100	10,0	16,0	23,5	50,0	120,0	41,0	10,0	71,0	M8x1	HTC-HSK-A100-10-120-1-0-A	30856747
100	12,0	18,0	25,6	50,0	120,0	46,0	10,0	72,0	M10x1	HTC-HSK-A100-12-120-1-0-A	30856749
100	14,0	22,0	29,2	50,0	120,0	46,0	10,0	68,0	M10x1	HTC-HSK-A100-14-120-1-0-A	30856751
100	16,0	24,0	31,2	50,0	120,0	49,0	10,0	68,0	M12x1	HTC-HSK-A100-16-120-1-0-A	30856752
100	18,0	26,0	33,3	50,0	120,0	49,0	10,0	69,0	M12x1	HTC-HSK-A100-18-120-1-0-A	30856753
100	20,0	28,0	35,3	50,0	120,0	51,0	10,0	69,0	M16x1	HTC-HSK-A100-20-120-1-0-A	30856754

Dimensions in mm.

Additional dimensions available upon request.

For information on use, scope of delivery and design as well as additional information on the product, see the following page.

HighTorque Chuck HTC

With axial tool length adjustment

HSK-A (hollow shank taper form A) shank according to DIN 69893-1

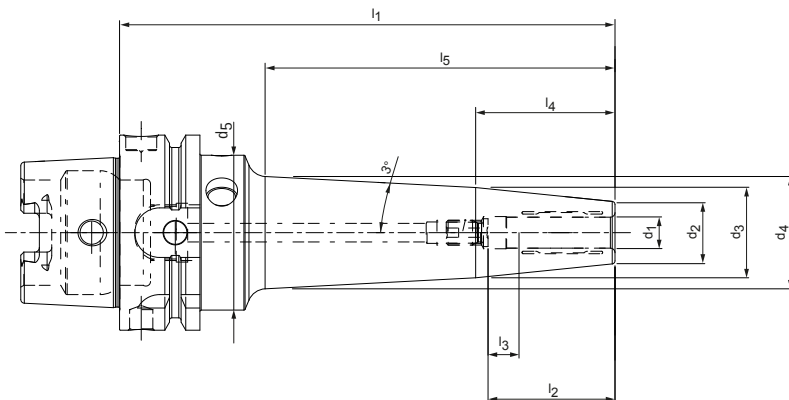

Narrow design 3°, optimised contour for maximum bending resistance

HSK-A	Dimensions										G	Specification	Order no.
	d ₁	d ₂	d ₃	d ₄	d ₅	l ₁	l ₂	l ₃	l ₄	l ₅			
63	3,0	13,0	27,3	31,5	50,0	160,0	28,0	16,0	70,0	110,0	M2,5	HTC-HSK-A063-03-160-1-0-A	30858322
63	3,0	13,0	27,3	35,8	50,0	200,0	28,0	16,0	70,0	151,0	M2,5	HTC-HSK-A063-03-200-1-0-A	30858329
63	4,0	14,0	28,3	32,5	50,0	160,0	28,0	12,0	70,0	110,0	M2,5	HTC-HSK-A063-04-160-1-0-A	30858323
63	4,0	14,0	28,3	36,8	50,0	200,0	28,0	12,0	70,0	151,0	M2,5	HTC-HSK-A063-04-200-1-0-A	30858330
63	5,0	15,0	29,3	33,5	50,0	160,0	28,0	8,0	70,0	110,0	M2,5	HTC-HSK-A063-05-160-1-0-A	30858324
63	5,0	15,0	29,3	37,8	50,0	200,0	28,0	8,0	70,0	151,0	M2,5	HTC-HSK-A063-05-200-1-0-A	30858331
63	6,0	16,0	28,2	33,6	50,0	160,0	37,0	10,0	60,0	111,0	M5	HTC-HSK-A063-06-160-1-0-A	30727647
63	6,0	16,0	28,2	37,9	50,0	200,0	37,0	10,0	60,0	152,0	M5	HTC-HSK-A063-06-200-1-0-A	30720812
63	8,0	18,0	28,2	34,6	50,0	160,0	37,0	10,0	50,0	111,0	M6	HTC-HSK-A063-08-160-1-0-A	30727648
63	8,0	18,0	28,2	38,9	50,0	200,0	37,0	10,0	50,0	152,0	M6	HTC-HSK-A063-08-200-1-0-A	30720815
63	10,0	20,0	29,2	36,3	50,0	160,0	41,0	10,0	45,0	113,0	M8x1	HTC-HSK-A063-10-160-1-0-A	30727650
63	10,0	20,0	29,2	40,6	50,0	200,0	41,0	10,0	45,0	154,0	M8x1	HTC-HSK-A063-10-200-1-0-A	30720816
63	12,0	22,0	30,2	37,8	50,0	160,0	46,0	10,0	40,0	113,0	M10x1	HTC-HSK-A063-12-160-1-0-A	30727651
63	12,0	22,0	30,2	42,1	50,0	200,0	46,0	10,0	40,0	154,0	M10x1	HTC-HSK-A063-12-200-1-0-A	30720817
63	14,0	26,0	34,2	41,8	50,0	160,0	46,0	10,0	40,0	113,0	M10x1	HTC-HSK-A063-14-160-1-0-A	30858325
63	14,0	26,0	34,2	46,1	50,0	200,0	46,0	10,0	40,0	154,0	M10x1	HTC-HSK-A063-14-200-1-0-A	30858332
63	16,0	28,0	36,2	43,8	50,0	160,0	49,0	10,0	40,0	113,0	M12x1	HTC-HSK-A063-16-160-1-0-A	30858326
63	16,0	28,0	36,2	48,1	50,0	200,0	49,0	10,0	40,0	154,0	M12x1	HTC-HSK-A063-16-200-1-0-A	30858333
63	18,0	30,0	36,1	45,1	50,0	160,0	49,0	10,0	30,0	115,0	M12x1	HTC-HSK-A063-18-160-1-0-A	30858327
63	18,0	30,0	36,1	49,4	50,0	200,0	49,0	10,0	30,0	156,0	M12x1	HTC-HSK-A063-18-200-1-0-A	30858334
63	20,0	32,0	38,1	47,1	50,0	160,0	51,0	10,0	30,0	115,0	M16x1	HTC-HSK-A063-20-160-1-0-A	30858328
63	20,0	32,0	38,1	49,1	50,0	200,0	51,0	10,0	30,0	156,0	M16x1	HTC-HSK-A063-20-200-1-0-A	30858335

Dimensions in mm.

Additional dimensions available upon request.

Use: For clamping tools with smooth cylindrical shanks according to DIN 1835 form A, DIN 6535 form HA as well as with recesses according to DIN 1835 form B, E and DIN 6535 form HB, HE directly and with reducing sleeve in the clamping diameter. The clamping diameter is designed for a shank tolerance of h6.

Scope of delivery: With length adjustment screw, without coolant tube.

Design: Highest tool life and production quality when using smooth cylindrical shanks according to DIN 1835 form A and DIN 6535 form HA. With a projection length of 2.5xD (max. 50 mm) radial run-out accuracy 3 µm. When using cylindrical shanks with an in-

clined clamping surface (form E and form HE), the accuracy may be impaired.

Note: Coolant supply via central through hole. Coolant tubes, code carrier, reducing sleeves to reduce the clamping diameter (if the reducing sleeve is used, the accuracy may be impaired), see section "Accessories, spare parts and measuring equipment". Length adjustment screws available on request.

Balancing quality: G 2.5 with 25,000 rpm in delivery status.

HighTorque Chuck HTC

With axial tool length adjustment

SK shank according to ISO 7388-1 Form AD/AF

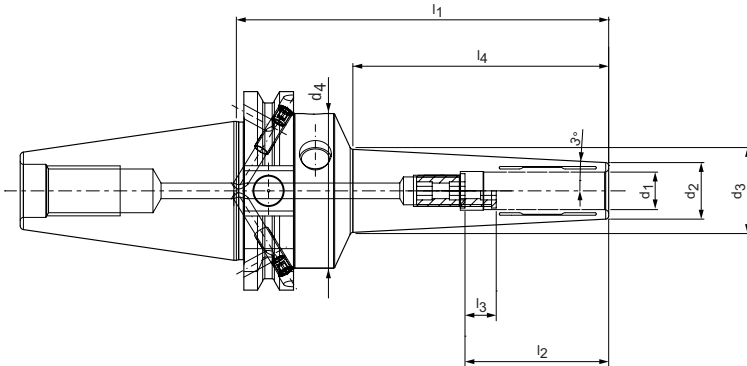

3° slim design

Steep taper	Dimensions								G	Specification	Order no.
	d_1	d_2	d_3	d_4	l_1	l_2	l_3	l_4			
30*	3,0	9,0	13,2	40,0	80,0	28,0	16,0	40,0	M2,5	HTC-SK030-03-80-1-0-A	30817986
30*	4,0	10,0	14,2	40,0	80,0	28,0	12,0	40,0	M2,5	HTC-SK030-04-80-1-0-A	30817987
30*	5,0	11,0	15,3	40,0	80,0	28,0	8,0	41,0	M2,5	HTC-SK030-05-80-1-0-A	30817988
30*	6,0	12,0	16,3	40,0	80,0	37,0	10,0	41,0	M5	HTC-SK030-06-80-1-0-A	30817989
30*	8,0	14,0	18,3	40,0	80,0	37,0	10,0	41,0	M6	HTC-SK030-08-80-1-0-A	30817990
30*	10,0	16,0	20,5	40,0	80,0	41,0	10,0	42,0	M8x1	HTC-SK030-10-80-1-0-A	30817991
30*	12,0	18,0	22,5	40,0	80,0	46,0	10,0	42,0	M8x1	HTC-SK030-12-80-1-0-A	30817992
40	3,0	9,0	17,4	49,5	120,0	28,0	16,0	80,0	M2,5	HTC-SK040-03-120-3-0-A	30781267
40	4,0	10,0	18,4	49,5	120,0	28,0	12,0	80,0	M2,5	HTC-SK040-04-120-3-0-A	30781270
40	5,0	11,0	19,4	49,5	120,0	28,0	8,0	80,0	M2,5	HTC-SK040-05-120-3-0-A	30781273
40	6,0	12,0	20,4	49,5	120,0	37,0	10,0	80,0	M5	HTC-SK040-06-120-3-0-A	30655457
40	8,0	14,0	22,4	49,5	120,0	37,0	10,0	80,0	M6	HTC-SK040-08-120-3-0-A	30655458
40	10,0	16,0	24,5	49,5	120,0	41,0	10,0	81,0	M8x1	HTC-SK040-10-120-3-0-A	30655459
40	12,0	18,0	26,6	49,5	120,0	46,0	10,0	82,0	M10x1	HTC-SK040-12-120-3-0-A	30655460
40	14,0	22,0	30,3	49,5	120,0	46,0	10,0	79,0	M10x1	HTC-SK040-14-120-3-0-A	30782699
40	16,0	24,0	32,3	49,5	120,0	49,0	10,0	79,0	M12x1	HTC-SK040-16-120-3-0-A	30782702
40	18,0	26,0	34,4	49,5	120,0	49,0	10,0	80,0	M12x1	HTC-SK040-18-120-3-0-A	30782708
40	20,0	28,0	36,4	49,5	120,0	51,0	10,0	80,0	M16x1	HTC-SK040-20-120-3-0-A	30782712

* Design: Taper shank size is not available in the AD/AF combination design.

Dimensions in mm.

Additional dimensions available upon request.

Use: For clamping tools with smooth cylindrical shanks according to DIN 1835 form A, DIN 6535 form HA as well as with recesses according to DIN 1835 form B, E and DIN 6535 form HB, HE directly and with reducing sleeve in the clamping diameter. The clamping diameter is designed for a shank tolerance of h6.

Scope of delivery: With length adjustment screw, without pull stud.

Design: Highest tool life and production quality when using smooth cylindrical shanks according to DIN 1835 form A and DIN 6535 form HA. With a projection length of 2.5xD (max. 50 mm) radial run-out accuracy 3 μ m. When using cylindrical shanks with an inclined clamp

ing surface (form E and form HE), the accuracy may be impaired. Basic setting Form AD, if Form AF is required, please specify this when placing your order.

Note: Coolant supply via central through hole. Pull stud, reducing sleeves to reduce the clamping diameter (if the reducing sleeve is used, the accuracy may be impaired), see section "Accessories, spare parts and measuring equipment". Length adjustment screws available on request.

Balancing quality: G 2.5 with 25,000 rpm in delivery status.

HighTorque Chuck HTC

With axial tool length adjustment

SK shank according to ISO 7388-1 Form AD/AF

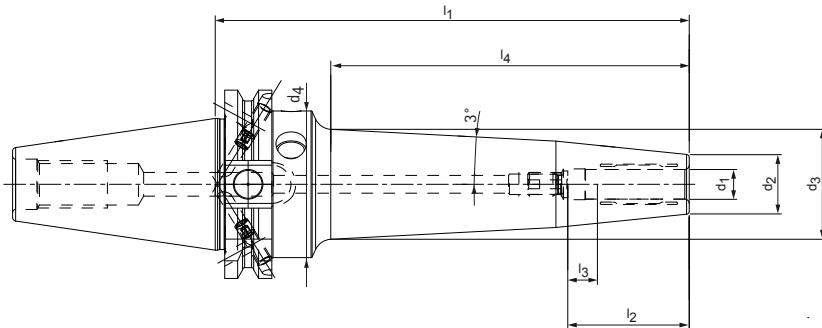

Narrow design 3°, optimised contour for maximum bending resistance

Steep taper	Dimensions								G	Specification	Order no.
	d ₁	d ₂	d ₃	d ₄	l ₁	l ₂	l ₃	l ₄			
40	3,0	13,0	32,2	49,5	160,0	28,0	16,0	117,0	M2,5	HTC-SK040-03-160-3-0-A	30858308
40	3,0	13,0	36,5	49,5	200,0	28,0	16,0	158,0	M2,5	HTC-SK040-03-200-3-0-A	30858315
40	4,0	14,0	33,2	49,5	160,0	28,0	12,0	117,0	M2,5	HTC-SK040-04-160-3-0-A	30858309
40	4,0	14,0	37,5	49,5	200,0	28,0	12,0	158,0	M2,5	HTC-SK040-04-200-3-0-A	30858316
40	5,0	15,0	34,2	49,5	160,0	28,0	8,0	117,0	M2,5	HTC-SK040-05-160-3-0-A	30858310
40	5,0	15,0	38,5	49,5	200,0	28,0	8,0	158,0	M2,5	HTC-SK040-05-200-3-0-A	30858317
40	6,0	16,0	34,4	49,5	160,0	37,0	10,0	119,0	M5	HTC-SK040-06-160-3-0-A	30817993
40	6,0	16,0	38,8	49,5	200,0	37,0	10,0	160,5	M5	HTC-SK040-06-200-3-0-A	30817997
40	8,0	18,0	35,5	49,5	160,0	37,0	10,0	119,5	M6	HTC-SK040-08-160-3-0-A	30817994
40	8,0	18,0	39,8	49,5	200,0	37,0	10,0	160,5	M6	HTC-SK040-08-200-3-0-A	30817998
40	10,0	20,0	37,2	49,5	160,0	41,0	10,0	121,0	M8x1	HTC-SK040-10-160-3-0-A	30817995
40	10,0	20,0	41,5	49,5	200,0	41,0	10,0	162,0	M8x1	HTC-SK040-10-200-3-0-A	30817999
40	12,0	22,0	38,8	49,5	160,0	46,0	10,0	122,0	M10x1	HTC-SK040-12-160-3-0-A	30817996
40	12,0	22,0	43,1	49,5	200,0	46,0	10,0	163,0	M10x1	HTC-SK040-12-200-3-0-A	30818000
40	14,0	26,0	42,7	49,5	160,0	46,0	10,0	121,0	M10x1	HTC-SK040-14-160-3-0-A	30858311
40	14,0	26,0	47,0	49,5	200,0	46,0	10,0	162,0	M10x1	HTC-SK040-14-200-3-0-A	30858318
40	16,0	28,0	44,7	49,5	160,0	49,0	10,0	121,0	M12x1	HTC-SK040-16-160-3-0-A	30858312
40	16,0	28,0	46,8	49,5	200,0	49,0	10,0	162,0	M12x1	HTC-SK040-16-200-3-0-A	30858319
40	18,0	30,0	45,7	49,5	160,0	49,0	10,0	122,0	M12x1	HTC-SK040-18-160-3-0-A	30858313
40	18,0	30,0	47,8	49,5	200,0	49,0	10,0	163,0	M12x1	HTC-SK040-18-200-3-0-A	30858320
40	20,0	32,0	47,8	49,5	160,0	51,0	10,0	122,0	M16x1	HTC-SK040-20-160-3-0-A	30858314
40	20,0	32,0	47,4	49,5	200,0	51,0	10,0	163,0	M16x1	HTC-SK040-20-200-3-0-A	30858321

Dimensions in mm.

Additional dimensions available upon request.

Use: For clamping tools with smooth cylindrical shanks according to DIN 1835 form A, DIN 6535 form HA as well as with recesses according to DIN 1835 form B, E and DIN 6535 form HB, HE directly and with reducing sleeve in the clamping diameter. The clamping diameter is designed for a shank tolerance of h6.

Scope of delivery: With length adjustment screw, without pull stud.

Design: Highest tool life and production quality when using smooth cylindrical shanks according to DIN 1835 form A and DIN 6535 form HA. With a projection length of 2.5xD (max. 50 mm) radial run-out accuracy 3 µm. When using cylindrical shanks with an in-

clined clamping surface (form E and form HE), the accuracy may be impaired. Basic setting Form AD; if Form AF is required, please specify this when placing your order.

Note: Coolant supply via central through hole. Pull stud, reducing sleeves to reduce the clamping diameter (if the reducing sleeve is used, the accuracy may be impaired), see section "Accessories, spare parts and measuring equipment". Length adjustment screws available on request.

Balancing quality: G 2.5 with 25,000 rpm in delivery status.

HighTorque Chuck HTC

With axial tool length adjustment

Shank BT according to ISO 7388-2 Form JD/JS (JIS B 6339)

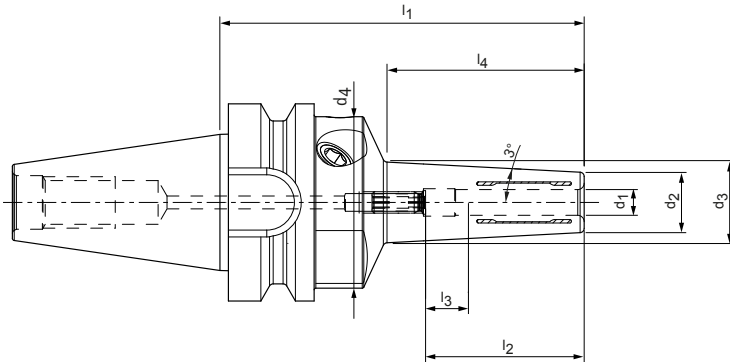

3° slim design

BT	Dimensions								G	Specification	Order no.
	d ₁	d ₂	d ₃	d ₄	l ₁	l ₂	l ₃	l ₄			
30*	3,0	10,0	14,8	40,0	85,0	28,0	16,0	45,0	M2,5	HTC-BT030-03-85-1-0-A	30819403
30*	4,0	12,0	16,8	40,0	85,0	28,0	12,0	45,0	M2,5	HTC-BT030-04-85-1-0-A	30819404
30*	5,0	13,0	17,8	40,0	85,0	28,0	8,0	45,0	M2,5	HTC-BT030-05-85-1-0-A	30819405
30*	6,0	14,0	18,9	40,0	85,0	37,0	10,0	46,0	M5	HTC-BT030-06-85-1-0-A	30819406
30*	8,0	16,0	20,9	40,0	85,0	37,0	10,0	46,0	M6	HTC-BT030-08-85-1-0-A	30819407
30*	10,0	18,0	23,0	40,0	85,0	41,0	10,0	47,0	M8x1	HTC-BT030-10-85-1-0-A	30819408
30*	12,0	20,0	25,0	40,0	85,0	46,0	10,0	47,0	M8x1	HTC-BT030-12-85-1-0-A	30819409
30*	14,0	24,0	29,0	40,0	85,0	46,0	10,0	47,0	M8x1	HTC-BT030-14-85-1-0-A	30819410
30*	16,0	26,0	31,1	40,0	85,0	49,0	10,0	48,0	M8x1	HTC-BT030-16-85-1-0-A	30819411
30*	18,0	28,0	33,1	40,0	85,0	49,0	10,0	48,0	M8x1	HTC-BT030-18-85-1-0-A	30819412
30*	20,0	30,0	35,2	40,0	85,0	51,0	10,0	49,0	M8x1	HTC-BT030-20-85-1-0-A	30819413
40	3,0	9,0	16,6	49,5	120,0	28,0	16,0	72,0	M2,5	HTC-BT040-03-120-3-0-A	30781286
40	4,0	10,0	17,6	49,5	120,0	28,0	12,0	72,0	M2,5	HTC-BT040-04-120-3-0-A	30781287
40	5,0	11,0	18,6	49,5	120,0	28,0	8,0	72,0	M2,5	HTC-BT040-05-120-3-0-A	30781290
40	6,0	12,0	19,6	49,5	120,0	37,0	10,0	72,0	M5	HTC-BT040-06-120-3-0-A	30757078
40	8,0	14,0	21,6	49,5	120,0	37,0	10,0	72,0	M6	HTC-BT040-08-120-3-0-A	30757080
40	10,0	16,0	23,7	49,5	120,0	41,0	10,0	73,0	M8x1	HTC-BT040-10-120-3-0-A	30757081
40	12,0	18,0	25,8	49,5	120,0	46,0	10,0	74,0	M10x1	HTC-BT040-12-120-3-0-A	30757082
40	14,0	22,0	29,5	49,5	120,0	46,0	10,0	71,0	M10x1	HTC-BT040-14-120-3-0-A	30858267
40	16,0	24,0	31,5	49,5	120,0	49,0	10,0	71,0	M12x1	HTC-BT040-16-120-3-0-A	30858268
40	18,0	26,0	33,6	49,5	120,0	49,0	10,0	72,0	M12x1	HTC-BT040-18-120-3-0-A	30858269
40	20,0	28,0	35,6	49,5	120,0	51,0	10,0	72,0	M16x1	HTC-BT040-20-120-3-0-A	30858270

* Design: Taper shank size is not available in the JD/JF combination design.

Dimensions in mm.

Additional dimensions available upon request.

Use: For clamping tools with smooth cylindrical shanks according to DIN 1835 form A, DIN 6535 form HA as well as with recesses according to DIN 1835 form B, E and DIN 6535 form HB, HE directly and with reducing sleeve in the clamping diameter. The clamping diameter is designed for a shank tolerance of h6.

Scope of delivery: With length adjustment screw, without pull stud.

Design: Highest tool life and production quality when using smooth cylindrical shanks according to DIN 1835 form A and DIN 6535 form HA. With a projection length of 2.5xD (max. 50 mm) radial run-out accuracy 3 µm. When using cylindrical shanks with an inclined clamp

ing surface (form E and form HE), the accuracy may be impaired. Basic setting Form JD; if Form JF is required, please state with the order.

Note: Coolant supply via central through hole. Pull stud, reducing sleeves to reduce the clamping diameter (if the reducing sleeve is used, the accuracy may be impaired), see section "Accessories, spare parts and measuring equipment". Length adjustment screws available on request.

Balancing quality: G 2.5 with 25,000 rpm in delivery status.

HighTorque Chuck HTC

With axial tool length adjustment

Shank BT according to ISO 7388-2 Form JD/JS (JIS B 6339)

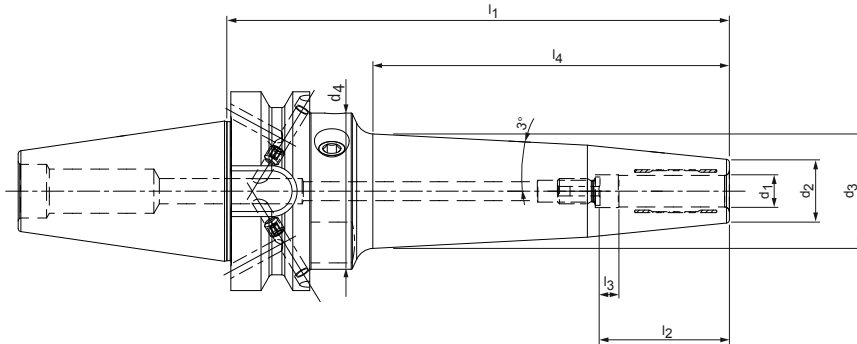

Narrow design 3°, optimised contour for maximum bending resistance

BT	Dimensions								G	Specification	Order no.
	d ₁	d ₂	d ₃	d ₄	l ₁	l ₂	l ₃	l ₄			
40	3,0	13,0	31,4	49,5	160,0	28,0	16,0	109,0	M2,5	HTC-BT040-03-160-3-0-A	30858271
40	3,0	13,0	35,7	49,5	200,0	28,0	16,0	150,0	M2,5	HTC-BT040-03-200-3-0-A	30858283
40	4,0	14,0	32,4	49,5	160,0	28,0	12,0	109,0	M2,5	HTC-BT040-04-160-3-0-A	30858272
40	4,0	14,0	36,7	49,5	200,0	28,0	12,0	150,0	M2,5	HTC-BT040-04-200-3-0-A	30858284
40	5,0	15,0	33,4	49,5	160,0	28,0	8,0	109,0	M2,5	HTC-BT040-05-160-3-0-A	30858273
40	5,0	15,0	37,7	49,5	200,0	28,0	8,0	150,0	M2,5	HTC-BT040-05-200-3-0-A	30858285
40	6,0	16,0	33,6	49,5	160,0	37,0	10,0	111,0	M5	HTC-BT040-06-160-3-0-A	30858274
40	6,0	16,0	37,9	49,5	200,0	37,0	10,0	152,5	M5	HTC-BT040-06-200-3-0-A	30858286
40	8,0	18,0	34,7	49,5	160,0	37,0	10,0	111,5	M6	HTC-BT040-08-160-3-0-A	30858275
40	8,0	18,0	39,0	49,5	200,0	37,0	10,0	152,5	M6	HTC-BT040-08-200-3-0-A	30858287
40	10,0	20,0	36,3	49,5	160,0	41,0	10,0	113,0	M8x1	HTC-BT040-10-160-3-0-A	30858277
40	10,0	20,0	40,6	49,5	200,0	41,0	10,0	154,0	M8x1	HTC-BT040-10-200-3-0-A	30858288
40	12,0	22,0	37,9	49,5	160,0	46,0	10,0	114,0	M10x1	HTC-BT040-12-160-3-0-A	30858278
40	12,0	22,0	42,2	49,5	200,0	46,0	10,0	155,0	M10x1	HTC-BT040-12-200-3-0-A	30858289
40	14,0	26,0	41,8	49,5	160,0	46,0	10,0	113,0	M10x1	HTC-BT040-14-160-3-0-A	30858279
40	14,0	26,0	46,1	49,5	200,0	46,0	10,0	154,0	M10x1	HTC-BT040-14-200-3-0-A	30858290
40	16,0	28,0	43,8	49,5	160,0	49,0	10,0	113,0	M12x1	HTC-BT040-16-160-3-0-A	30858280
40	16,0	28,0	46,1	49,5	200,0	49,0	10,0	154,0	M12x1	HTC-BT040-16-200-3-0-A	30858291
40	18,0	30,0	44,9	49,5	160,0	49,0	10,0	114,0	M12x1	HTC-BT040-18-160-3-0-A	30858281
40	18,0	30,0	47,1	49,5	200,0	49,0	10,0	155,0	M12x1	HTC-BT040-18-200-3-0-A	30858292
40	20,0	32,0	46,9	49,5	160,0	51,0	10,0	114,0	M16x1	HTC-BT040-20-160-3-0-A	30858282
40	20,0	32,0	46,9	49,5	200,0	51,0	10,0	155,0	M16x1	HTC-BT040-20-200-3-0-A	30858293

Dimensions in mm.

Additional dimensions available upon request.

Use: For clamping tools with smooth cylindrical shanks according to DIN 1835 form A, DIN 6535 form HA as well as with recesses according to DIN 1835 form B, E and DIN 6535 form HB, HE directly and with reducing sleeve in the clamping diameter. The clamping diameter is designed for a shank tolerance of h6.

Scope of delivery: With length adjustment screw, without pull stud.

Design: Highest tool life and production quality when using smooth cylindrical shanks according to DIN 1835 form A and DIN 6535 form HA. With a projection length of 2.5xD (max. 50 mm) radial run-out accuracy 3 µm. When using cylindrical shanks with an in-

clined clamping surface (form E and form HE), the accuracy may be impaired.

Basic setting Form JD; if Form JF is required, please state with the order.

Note: Coolant supply via central through hole. Pull stud, reducing sleeves to reduce the clamping diameter (if the reducing sleeve is used, the accuracy may be impaired), see section "Accessories, spare parts and measuring equipment". Length adjustment screws available on request.

Balancing quality: G 2.5 with 25,000 rpm in delivery status.

HighTorque Chuck HTC

With axial tool length adjustment

Shank hollow shank taper E according to DIN 69893-5

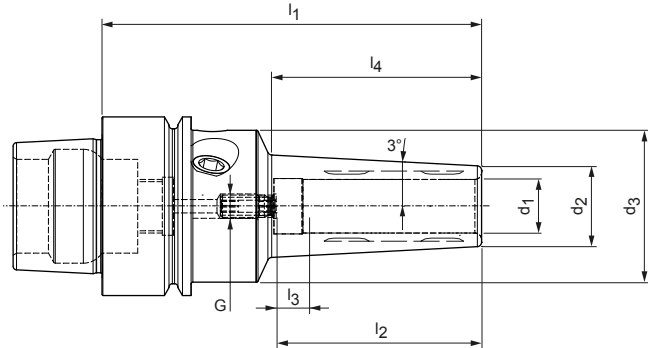

Slim design 3° | Available upon request

HSK-E	Dimensions							G	Specification	Order no.
	d ₁	d ₂	d ₃	l ₁	l ₂	l ₃	l ₄			
40	3,0	9,0	34,0	85,0	28,0	16,0	45,0	M2.5	HTC-HSK-E040-03-85-1-0-A	30817965
40	4,0	10,0	34,0	85,0	28,0	12,0	45,0	M2.5	HTC-HSK-E040-04-85-1-0-A	30817966
40	5,0	11,0	34,0	85,0	28,0	8,0	45,0	M2.5	HTC-HSK-E040-05-85-1-0-A	30817967
40	6,0	12,0	34,0	85,0	37,0	10,0	46,0	M5	HTC-HSK-E040-06-85-1-0-A	30817968
40	8,0	14,0	34,0	85,0	37,0	10,0	46,0	M6	HTC-HSK-E040-08-85-1-0-A	30817969
40	10,0	16,0	34,0	85,0	41,0	10,0	47,0	M5	HTC-HSK-E040-10-85-1-0-A	30817970
40	12,0	18,0	34,0	85,0	46,0	10,0	47,0	M5	HTC-HSK-E040-12-85-1-0-A	30817971
50	3,0	9,0	42,0	85,0	28,0	16,0	37,0	M2.5	HTC-HSK-E050-03-85-1-0-A	30817972
50	4,0	10,0	42,0	85,0	28,0	12,0	37,0	M2.5	HTC-HSK-E050-04-85-1-0-A	30817973
50	5,0	11,0	42,0	85,0	28,0	8,0	37,0	M2.5	HTC-HSK-E050-05-85-1-0-A	30817974
50	6,0	12,0	42,0	85,0	37,0	10,0	38,0	M5	HTC-HSK-E050-06-85-1-0-A	30817975
50	8,0	14,0	42,0	85,0	37,0	10,0	38,0	M6	HTC-HSK-E050-08-85-1-0-A	30817976
50	10,0	16,0	42,0	85,0	41,0	10,0	39,0	M8x1	HTC-HSK-E050-10-85-1-0-A	30817977
50	12,0	18,0	42,0	85,0	46,0	10,0	39,0	M8x1	HTC-HSK-E050-12-85-1-0-A	30817978

Dimensions in mm.

Use: For clamping tools with smooth cylindrical shanks according to DIN 1835 form A, DIN 6535 form HA up to clamping diameter $d_1 = 12$ mm as well as with recesses according to DIN 1835 form B, E and DIN 6535 form HB, HE directly and without reducing sleeve in the clamping diameter. The clamping diameter is designed for a shank tolerance of h6.

Scope of delivery: With length adjustment screw, without coolant tube.

Design: Highest tool life and production quality when using smooth cylindrical shanks ac

ording to DIN 1835 form A and DIN 6535 form HA. With a projection length of $2.5 \times D$ (max. 50 mm) radial run-out accuracy $3 \mu\text{m}$. When using cylindrical shanks with an inclined clamping surface (form E and form HE), the accuracy may be impaired.

Note: Chuck with axial tool length adjustment. Coolant supply via central through hole.

Balancing quality: G 2.5 with 25,000 rpm in delivery status.

HighTorque Chuck HTC

With axial tool length adjustment

HSK-A (hollow shank taper form A) shank according to DIN 69893-1

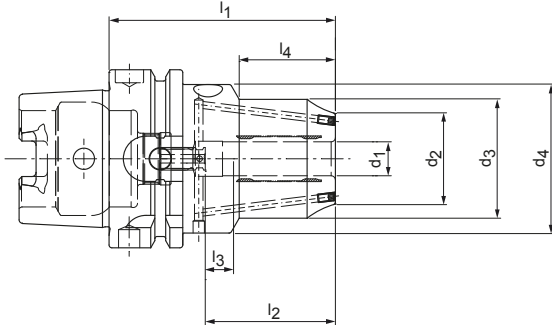

Short heavy design with two cooling channel bores, resealable

HSK-A	Dimensions								G	Specification	Order no.
	d ₁	d ₂	d ₃	d ₄	l ₁	l ₂	l ₃	l ₄			
63	12,0	32,0	42,0	52,5	80,0	46,0	10,0	34,0	M8x1	HTC-HSK-A063-12-080-1-0-A	30655666
63	16,0	38,0	46,0	52,5	80,0	49,0	10,0	35,0	M8x1	HTC-HSK-A063-16-080-1-0-A	30655667
63	20,0	41,0	49,0	52,5	80,0	51,0	10,0	36,0	M8x1	HTC-HSK-A063-20-080-1-0-A	30655668
100	12,0	32,0	42,0	52,5	90,0	46,0	10,0	34,0	M8x1	HTC-HSK-A100-12-090-1-0-A	31038802
100	20,0	41,0	49,0	52,5	90,0	51,0	10,0	36,0	M8x1	HTC-HSK-A100-20-090-1-0-A	31038803
100	32,0	57,0	68,0	72,0	105,0	61,0	10,0	42,0	M8x1	HTC-HSK-A100-32-105-1-0-A	31038804

Dimensions in mm.

Additional dimensions available upon request.

Use: For clamping tools with smooth cylindrical shanks according to DIN 1835 form A, DIN 6535 form HA as well as with recesses according to DIN 1835 form B, E and DIN 6535 form HB, HE directly and with reducing sleeve in the clamping diameter. The clamping diameter is designed for a shank tolerance of h6.

Scope of delivery: With length adjustment screw, without coolant tube.

Design: Highest tool life and production quality when using smooth cylindrical shanks according to DIN 1835 form A and DIN 6535 form HA. With a projection length of 2.5xD (max. 50 mm) radial run-out accuracy 3 µm. When using cylindrical shanks with an inclined clamp

ing surface (form E and form HE), the accuracy may be impaired.

Note: Coolant supply via central through hole. Coolant tubes, code carrier, reducing sleeves to reduce the clamping diameter (if the reducing sleeve is used, the accuracy may be impaired), see section "Accessories, spare parts and measuring equipment". Length adjustment screws available on request.

Balancing quality: G 2.5 with 25,000 rpm in delivery status.

HighTorque Chuck HTC

With axial tool length adjustment

Shank SK according to ISO 7388-1 Form AD/AF

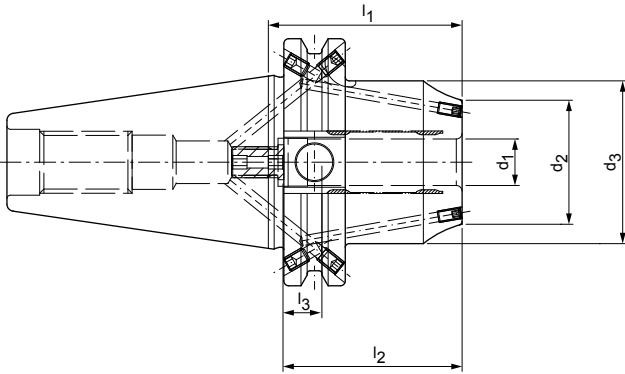

Short heavy design with two cooling channel bores, resealable

Steep taper	Dimensions						G	Specification	Order no.
	d_1	d_2	d_3	l_1	l_2	l_3			
40	12,0	32,0	42,0	50,0	46,0	10,0	M8x1	HTC-SK040-12-050-3-0-A	30655663
40	16,0	38,0	46,0	64,5	49,0	10,0	M12x1	HTC-SK040-16-065-3-0-A	30655664
40	20,0	41,0	49,0	64,5	51,0	10,0	M16x1	HTC-SK040-20-065-3-0-A	30655665

Dimensions in mm.

Additional dimensions available upon request.

Use: For clamping tools with smooth cylindrical shanks according to DIN 1835 form A, DIN 6535 form HA as well as with recesses according to DIN 1835 form B, E and DIN 6535 form HB, HE directly and with reducing sleeve in the clamping diameter. The clamping diameter is designed for a shank tolerance of h6.

Scope of delivery: With length adjustment screw, without pull stud.

Design: Highest tool life and production quality when using smooth cylindrical shanks according to DIN 1835 form A and DIN 6535 form HA. With a projection length of 2.5xD (max. 50 mm) radial run-out accuracy 3 μ m. When using cylindrical shanks with an inclined clamp

ing surface (form E and form HE), the accuracy may be impaired. Basic setting Form AD, if Form AF is required, please specify this when placing your order.

Note: Coolant supply via central through hole. Pull stud, reducing sleeves to reduce the clamping diameter (if the reducing sleeve is used, the accuracy may be impaired), see section "Accessories, spare parts and measuring equipment". Length adjustment screws available on request.

Balancing quality: G 2.5 with 25,000 rpm in delivery status.

HydroChuck

With axial tool length adjustment

Shank SK according to ISO 7388-1 Form AD

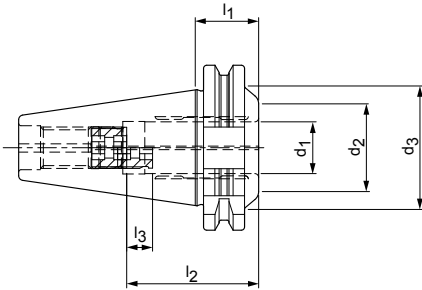

Ultra-short design

Steep taper	Dimensions						G	Specification	Order no.
	d_1	d_2	d_3	l_1	l_2	l_3			
40	20,0	34,0	48,0	24,5	51,0	10,0	M16x1	MHC-SK040-20-025-1-0-A	30524709

Dimensions in mm.

Additional dimensions available upon request.

Use: For clamping tools with smooth cylindrical shanks according to DIN 1835 form A, DIN 6535 form HA as well as with recesses according to DIN 1835 form B, E and DIN 6535 form HB, HE directly and with reducing sleeve in the clamping diameter. The clamping diameter is designed for a shank tolerance of h6.

Scope of delivery: With length adjustment screw, without pull stud.

Design: Highest tool life and production quality when using smooth cylindrical shanks according to DIN 1835 form A and DIN 6535 form HA. With a projection length of 2.5xD (max. 50 mm) radial run-out accuracy 3 μ m. When using cylindrical shanks with an inclined clamp

ing surface (form E and form HE), the accuracy may be impaired. Basic setting Form AD, if Form AF is required, please specify this when placing your order.

Note: Coolant supply via central through hole. Pull stud, reducing sleeves to reduce the clamping diameter (if the reducing sleeve is used, the accuracy may be impaired), see section "Accessories, spare parts and measuring equipment". Length adjustment screws available on request.

Balancing quality: G 2.5 with 25,000 rpm in delivery status.

ThermoChuck

With axial tool length adjustment

HSK-A (hollow shank taper form A) shank according to DIN 69893-1

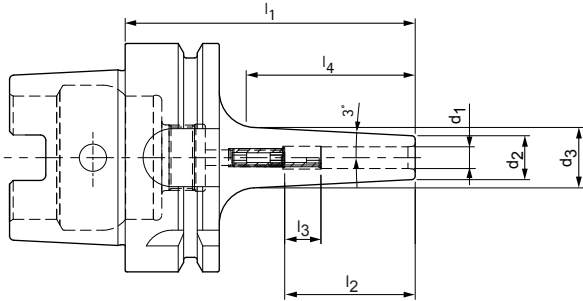

3° slim design

HSK-A	Dimensions							G	Specification	Order no.
	d_1	d_2	d_3	l_1	l_2	l_3	l_4			
63	3,0	9,0	13,7	80,0	28,0	16,0	44,5	M6	MTC-HSK-A063-03-080-1-0-A	30385147
63*	3,0	9,0	16,0	120,0	12,0	-	66,7	.	MTC-HSK-A063-03-120-1-0-W	30385148
63	4,0	10,0	14,7	80,0	28,0	12,0	44,5	M6	MTC-HSK-A063-04-080-1-0-A	30385150
63*	4,0	10,0	17,0	120,0	16,0	-	66,7	.	MTC-HSK-A063-04-120-1-0-W	30385151
63	5,0	11,0	15,7	80,0	30,0	10,0	44,5	M6	MTC-HSK-A063-05-080-1-0-A	30385153
63*	5,0	11,0	18,0	120,0	20,0	-	66,7	.	MTC-HSK-A063-05-120-1-0-W	30385154
63	6,0	12,0	16,7	80,0	36,0	10,0	44,5	M5	MTC-HSK-A063-06-080-1-0-A	30385156
63	6,0	12,0	20,9	120,0	36,0	10,0	84,5	M5	MTC-HSK-A063-06-120-1-0-A	30385157
63	6,0	12,0	24,0	160,0	36,0	10,0	114,4	M5	MTC-HSK-A063-06-160-1-0-A	30385158
63	6,0	12,0	24,0	200,0	36,0	10,0	114,4	M5	MTC-HSK-A063-06-200-1-0-A	30782721
63	8,0	14,0	18,7	80,0	36,0	10,0	44,5	M6	MTC-HSK-A063-08-080-1-0-A	30385159
63	8,0	14,0	22,9	120,0	36,0	10,0	84,5	M6	MTC-HSK-A063-08-120-1-0-A	30385160
63	8,0	14,0	26,0	160,0	36,0	10,0	114,4	M6	MTC-HSK-A063-08-160-1-0-A	30385161
63	8,0	14,0	26,0	200,0	36,0	10,0	114,4	M6	MTC-HSK-A063-08-200-1-0-A	30782722
63	10,0	16,0	21,2	85,0	41,0	10,0	49,5	M8x1	MTC-HSK-A063-10-085-1-0-A	30385162
63	10,0	16,0	24,9	120,0	41,0	10,0	84,5	M8x1	MTC-HSK-A063-10-120-1-0-A	30385163
63	10,0	16,0	28,0	160,0	41,0	10,0	114,4	M8x1	MTC-HSK-A063-10-160-1-0-A	30385164
63	10,0	16,0	28,0	200,0	41,0	10,0	114,4	M8x1	MTC-HSK-A063-10-200-1-0-A	30782723
63	12,0	18,0	23,8	90,0	47,0	10,0	54,5	M10x1	MTC-HSK-A063-12-090-1-0-A	30385165
63	12,0	18,0	26,9	120,0	47,0	10,0	84,5	M10x1	MTC-HSK-A063-12-120-1-0-A	30385166
63	12,0	18,0	30,0	160,0	47,0	10,0	114,4	M10x1	MTC-HSK-A063-12-160-1-0-A	30385167
63	12,0	18,0	30,0	200,0	47,0	10,0	114,4	M10x1	MTC-HSK-A063-12-200-1-0-A	30782724
63	14,0	20,0	25,8	90,0	47,0	10,0	54,5	M10x1	MTC-HSK-A063-14-090-1-0-A	30385168
63	14,0	20,0	28,9	120,0	47,0	10,0	84,5	M10x1	MTC-HSK-A063-14-120-1-0-A	30385169
63	14,0	20,0	32,0	160,0	47,0	10,0	114,4	M10x1	MTC-HSK-A063-14-160-1-0-A	30385170
63	14,0	20,0	32,0	200,0	47,0	10,0	114,4	M10x1	MTC-HSK-A063-14-200-1-0-A	30782725
63	16,0	22,0	28,5	95,0	50,0	10,0	61,9	M12x1	MTC-HSK-A063-16-095-1-0-A	30385171
63	16,0	22,0	31,2	120,0	50,0	10,0	86,9	M12x1	MTC-HSK-A063-16-120-1-0-A	30385172
63	16,0	22,0	34,0	160,0	50,0	10,0	114,4	M12x1	MTC-HSK-A063-16-160-1-0-A	30385173
63	16,0	22,0	34,0	200,0	50,0	10,0	114,4	M12x1	MTC-HSK-A063-16-200-1-0-A	30774763
63	18,0	24,0	30,5	95,0	50,0	10,0	61,9	M12x1	MTC-HSK-A063-18-095-1-0-A	30385174
63	18,0	24,0	33,2	120,0	50,0	10,0	86,9	M12x1	MTC-HSK-A063-18-120-1-0-A	30385175
63	18,0	24,0	36,0	160,0	50,0	10,0	114,4	M12x1	MTC-HSK-A063-18-160-1-0-A	30385176
63	18,0	24,0	36,0	200,0	50,0	10,0	114,4	M12x1	MTC-HSK-A063-18-200-1-0-A	30782726

ThermoChuck | Hollow shank taper form A shank as per DIN 69893-1 | With axial tool length adjustment | 3° slim design

HSK-A	Dimensions							G	Specification	Order no.
	d ₁	d ₂	d ₃	l ₁	l ₂	l ₃	l ₄			
63	20,0	26,0	33,1	100,0	52,0	10,0	66,9	M16x1	MTC-HSK-A063-20-100-1-0-A	30385177
63	20,0	26,0	35,2	120,0	52,0	10,0	86,9	M16x1	MTC-HSK-A063-20-120-1-0-A	30385178
63	20,0	26,0	38,0	160,0	52,0	10,0	114,4	M16x1	MTC-HSK-A063-20-160-1-0-A	30385179
63	20,0	26,0	38,0	200,0	52,0	10,0	114,4	M16x1	MTC-HSK-A063-20-200-1-0-A	30782727

* Without axial tool length adjustment.

Available on request

100	6,0	12,0	17,0	85,0	36,0	10,0	41,8	M5	MTC-HSK-A100-06-085-1-0-A	30611985
100	6,0	12,0	20,0	120,0	36,0	10,0	76,8	M5	MTC-HSK-A100-06-120-1-0-A	30611986
100	6,0	12,0	23,0	160,0	36,0	10,0	104,9	M5	MTC-HSK-A100-06-160-1-0-A	30611987
100	6,0	12,0	27,0	200,0	36,0	10,0	143,1	M5	MTC-HSK-A100-06-200-1-0-A	30611988
100	8,0	14,0	19,0	85,0	36,0	10,0	41,8	M6	MTC-HSK-A100-08-085-1-0-A	30611989
100	8,0	14,0	22,0	120,0	36,0	10,0	76,8	M6	MTC-HSK-A100-08-120-1-0-A	30611990
100	8,0	14,0	25,0	160,0	36,0	10,0	104,9	M6	MTC-HSK-A100-08-160-1-0-A	30611991
100	8,0	14,0	27,0	200,0	36,0	10,0	124,0	M6	MTC-HSK-A100-08-200-1-0-A	30611992
100	10,0	16,0	21,0	90,0	41,0	10,0	46,8	M8x1	MTC-HSK-A100-10-090-1-0-A	30611993
100	10,0	16,0	24,0	120,0	41,0	10,0	76,8	M8x1	MTC-HSK-A100-10-120-1-0-A	30611994
100	10,0	16,0	27,0	160,0	41,0	10,0	104,9	M8x1	MTC-HSK-A100-10-160-1-0-A	30611995
100	10,0	16,0	31,0	200,0	41,0	10,0	143,1	M8x1	MTC-HSK-A100-10-200-1-0-A	30611996
100	12,0	18,0	24,0	95,0	47,0	10,0	51,8	M10x1	MTC-HSK-A100-12-095-1-0-A	30611997
100	12,0	18,0	27,0	120,0	47,0	10,0	76,8	M10x1	MTC-HSK-A100-12-120-1-0-A	30611998
100	12,0	18,0	29,0	160,0	47,0	10,0	104,9	M10x1	MTC-HSK-A100-12-160-1-0-A	30611999
100	12,0	18,0	32,0	200,0	47,0	10,0	133,5	M10x1	MTC-HSK-A100-12-200-1-0-A	30612000
100	14,0	20,0	26,0	95,0	47,0	10,0	51,8	M10x1	MTC-HSK-A100-14-095-1-0-A	30612001
100	14,0	20,0	28,0	120,0	47,0	10,0	76,8	M10x1	MTC-HSK-A100-14-120-1-0-A	30612002
100	14,0	20,0	30,0	160,0	47,0	10,0	95,4	M10x1	MTC-HSK-A100-14-160-1-0-A	30612003
100	14,0	20,0	34,0	200,0	47,0	10,0	133,5	M10x1	MTC-HSK-A100-14-200-1-0-A	30612004
100	16,0	22,0	28,0	100,0	50,0	10,0	56,8	M12x1	MTC-HSK-A100-16-100-1-0-A	30612005
100	16,0	22,0	30,0	120,0	50,0	10,0	76,8	M12x1	MTC-HSK-A100-16-120-1-0-A	30612006
100	16,0	22,0	32,0	160,0	50,0	10,0	95,4	M12x1	MTC-HSK-A100-16-160-1-0-A	30612007
100	16,0	22,0	34,0	200,0	50,0	10,0	114,4	M12x1	MTC-HSK-A100-16-200-1-0-A	30612008
100	18,0	24,0	30,0	100,0	50,0	10,0	56,8	M12x1	MTC-HSK-A100-18-100-1-0-A	30612009
100	18,0	24,0	32,0	120,0	50,0	10,0	76,8	M12x1	MTC-HSK-A100-18-120-1-0-A	30612010
100	18,0	24,0	36,0	160,0	50,0	10,0	114,4	M12x1	MTC-HSK-A100-18-160-1-0-A	30612011
100	18,0	24,0	40,0	200,0	50,0	10,0	152,6	M12x1	MTC-HSK-A100-18-200-1-0-A	30612012
100	20,0	27,0	34,0	105,0	52,0	10,0	61,8	M16x1	MTC-HSK-A100-20-105-1-0-A	30612013
100	20,0	27,0	35,0	120,0	52,0	10,0	76,8	M16x1	MTC-HSK-A100-20-120-1-0-A	30612014
100	20,0	27,0	42,0	160,0	52,0	10,0	104,9	M16x1	MTC-HSK-A100-20-160-1-0-A	30612015
100	20,0	27,0	42,0	200,0	52,0	10,0	143,1	M16x1	MTC-HSK-A100-20-200-1-0-A	30612016

Dimensions in mm.

Additional dimensions available upon request.

Scope of delivery: With built-in, drilled through length adjustment screw. Without fine balancing screws and coolant tube.

Design: Permissible run-out variation of the hollow taper shank to the clamping diameter d₁ = 3 µm. The clamping diameter is designed for a shank tolerance of h6.

Note: Coolant tube and code carrier, see section "Accessories, spare parts and measuring equipment". Length adjustment screws and fine balancing screws available on request.

For notes on coding system, see chapter "Technical appendix".

Balancing quality: G 2.5 with 25,000 rpm in delivery status.

ThermoChuck

With axial tool length adjustment

SK shank according to ISO 7388-1 Form AD/AF

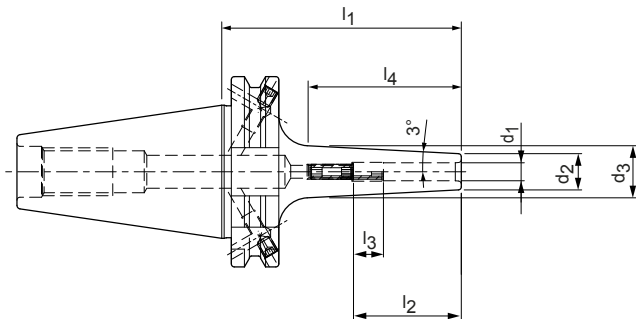

3° slim design

Steep taper	Dimensions							G	Specification	Order no.
	d ₁	d ₂	d ₃	l ₁	l ₂	l ₃	l ₄			
40	3,0	9,0	14,4	80,0	28,0	16,0	51,4	M6	MTC-SK040-03-080-3-0-A	30385180
40*	3,0	9,0	16,0	120,0	12,0	-	66,7	-	MTC-SK040-03-120-3-0-W	30385181
40	4,0	10,0	15,4	80,0	28,0	12,0	51,4	M6	MTC-SK040-04-080-3-0-A	30385183
40*	4,0	10,0	17,0	120,0	16,0	-	66,7	-	MTC-SK040-04-120-3-0-W	30385184
40	5,0	11,0	16,4	80,0	30,0	10,0	51,4	M6	MTC-SK040-05-080-3-0-A	30385186
40*	5,0	11,0	18,0	120,0	20,0	-	66,7	-	MTC-SK040-05-120-3-0-W	30385187
40	6,0	12,0	17,4	80,0	36,0	10,0	51,4	M5	MTC-SK040-06-080-3-0-A	30385189
40	6,0	12,0	21,6	120,0	36,0	10,0	91,4	M5	MTC-SK040-06-120-3-0-A	30385190
40	6,0	12,0	24,0	160,0	36,0	10,0	114,4	M5	MTC-SK040-06-160-3-0-A	30385191
40	6,0	12,0	24,0	200,0	36,0	10,0	114,4	M5	MTC-SK040-06-200-3-0-A	30797077
40	8,0	14,0	19,4	80,0	36,0	10,0	51,4	M6	MTC-SK040-08-080-3-0-A	30385192
40	8,0	14,0	23,6	120,0	36,0	10,0	91,4	M6	MTC-SK040-08-120-3-0-A	30385193
40	8,0	14,0	26,0	160,0	36,0	10,0	114,4	M6	MTC-SK040-08-160-3-0-A	30385194
40	8,0	14,0	26,0	200,0	36,0	10,0	114,4	M6	MTC-SK040-08-200-3-0-A	30797078
40	10,0	16,0	21,4	80,0	41,0	10,0	51,4	M8x1	MTC-SK040-10-080-3-0-A	30385195
40	10,0	16,0	25,6	120,0	41,0	10,0	91,4	M8x1	MTC-SK040-10-120-3-0-A	30385196
40	10,0	16,0	28,0	160,0	41,0	10,0	114,4	M8x1	MTC-SK040-10-160-3-0-A	30385197
40	10,0	16,0	28,0	200,0	41,0	10,0	114,4	M8x1	MTC-SK040-10-200-3-0-A	30797080
40	12,0	18,0	23,4	80,0	47,0	10,0	51,4	M10x1	MTC-SK040-12-080-3-0-A	30385198
40	12,0	18,0	27,9	120,0	47,0	10,0	93,8	M10x1	MTC-SK040-12-120-3-0-A	30385199
40	12,0	18,0	30,0	160,0	47,0	10,0	114,4	M10x1	MTC-SK040-12-160-3-0-A	30385200
40	12,0	18,0	30,0	200,0	47,0	10,0	114,4	M10x1	MTC-SK040-12-200-3-0-A	30797081
40	14,0	20,0	25,7	80,0	47,0	10,0	53,8	M10x1	MTC-SK040-14-080-3-0-A	30385201
40	14,0	20,0	30,1	120,0	47,0	10,0	96,2	M10x1	MTC-SK040-14-120-3-0-A	30385202
40	14,0	20,0	32,0	160,0	47,0	10,0	114,4	M10x1	MTC-SK040-14-160-3-0-A	30385203
40	14,0	20,0	32,0	200,0	47,0	10,0	114,4	M10x1	MTC-SK040-14-200-3-0-A	30797082
40	16,0	22,0	27,7	80,0	50,0	10,0	53,8	M12x1	MTC-SK040-16-080-3-0-A	30385204
40	16,0	22,0	32,1	120,0	50,0	10,0	96,2	M12x1	MTC-SK040-16-120-3-0-A	30385205
40	16,0	22,0	34,0	160,0	50,0	10,0	114,4	M12x1	MTC-SK040-16-160-3-0-A	30385206
40	16,0	22,0	34,0	200,0	50,0	10,0	114,4	M12x1	MTC-SK040-16-200-3-0-A	30797083
40	18,0	24,0	29,7	80,0	50,0	10,0	53,8	M12x1	MTC-SK040-18-080-3-0-A	30385207
40	18,0	24,0	34,4	120,0	50,0	10,0	98,5	M12x1	MTC-SK040-18-120-3-0-A	30385208
40	18,0	24,0	36,0	160,0	50,0	10,0	114,4	M12x1	MTC-SK040-18-160-3-0-A	30385209
40	18,0	24,0	36,0	200,0	50,0	10,0	114,4	M12x1	MTC-SK040-18-200-3-0-A	30797086

ThermoChuck | SK shank in accordance with ISO 7388-1 Form AD/AF | with axial tool length adjustment | 3° slim design

Steep taper	Dimensions							G	Specification	Order no.
	d ₁	d ₂	d ₃	l ₁	l ₂	l ₃	l ₄			
40	20,0	26,0	31,9	80,0	52,0	10,0	56,2	M16x1	MTC-SK040-20-080-3-0-A	30385210
40	20,0	26,0	36,4	120,0	52,0	10,0	98,5	M16x1	MTC-SK040-20-120-3-0-A	30385211
40	20,0	26,0	38,0	160,0	52,0	10,0	114,4	M16x1	MTC-SK040-20-160-3-0-A	30385212
40	20,0	26,0	38,0	200,0	52,0	10,0	114,4	M16x1	MTC-SK040-20-200-3-0-A	30797087

* Without axial tool length adjustment.

Dimensions in mm.

Additional dimensions available upon request.

Scope of delivery: With built-in, drilled through length adjustment screw. Without fine balancing screws or pull studs.

Design: Permissible run-out variation on the taper shank in relation to the clamping diameter d₁ = 3 µm. The clamping diameter is designed for a shank tolerance of h6. Basic set-

ting Form AD, if Form AF is required, please specify this when placing your order.

Note: For pull stud, see section "Accessories, spare parts and measuring equipment".

Length adjustment screws and fine balancing screws available on request.

Balancing quality: G 2.5 with 25,000 rpm in delivery status.

ThermoChuck

With axial tool length adjustment

Shank BT according to ISO 7388-2 Form JD/JF (JIS B 6339)

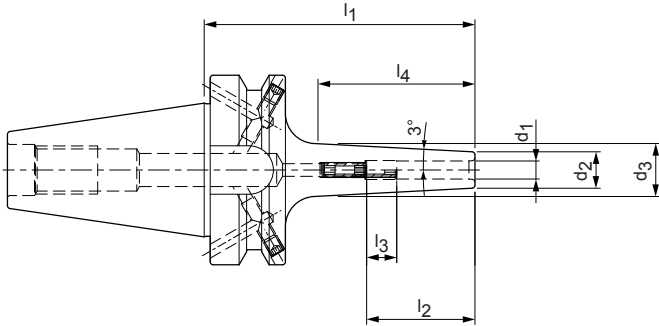

3° slim design

BT	Dimensions							G	Specification	Order no.
	d ₁	d ₂	d ₃	l ₁	l ₂	l ₃	l ₄			
40	3,0	9,0	14,7	90,0	28,0	16,0	53,5	M6	MTC-BT040-03-090-3-0-A	30385213
40*	3,0	9,0	16,0	120,0	12,0	-	66,7	-	MTC-BT040-03-120-3-0-W	30385214
40	4,0	10,0	15,7	90,0	28,0	12,0	53,5	M6	MTC-BT040-04-090-3-0-A	30385216
40*	4,0	10,0	17,0	120,0	16,0	-	66,7	-	MTC-BT040-04-120-3-0-W	30385217
40*	5,0	11,0	16,7	90,0	30,0	10,0	53,5	M6	MTC-BT040-05-090-3-0-A	30385219
40*	5,0	11,0	18,0	120,0	20,0	-	66,7	-	MTC-BT040-05-120-3-0-W	30385220
40	6,0	12,0	17,7	90,0	36,0	10,0	53,5	M5	MTC-BT040-06-090-3-0-A	30385222
40	6,0	12,0	20,8	120,0	36,0	10,0	83,5	M5	MTC-BT040-06-120-3-0-A	30385223
40	6,0	12,0	24,0	160,0	36,0	10,0	114,4	M5	MTC-BT040-06-160-3-0-A	30385224
40	6,0	12,0	24,0	200,0	36,0	10,0	114,4	M5	MTC-BT040-06-200-3-0-A	30654918
40	8,0	14,0	19,7	90,0	36,0	10,0	53,5	M6	MTC-BT040-08-090-3-0-A	30385225
40	8,0	14,0	22,8	120,0	36,0	10,0	83,5	M6	MTC-BT040-08-120-3-0-A	30385226
40	8,0	14,0	26,0	160,0	36,0	10,0	114,4	M6	MTC-BT040-08-160-3-0-A	30385227
40	8,0	14,0	26,0	200,0	36,0	10,0	114,4	M6	MTC-BT040-08-200-3-0-A	30654919
40	10,0	16,0	21,7	90,0	41,0	10,0	53,5	M8x1	MTC-BT040-10-090-3-0-A	30385228
40	10,0	16,0	24,8	120,0	41,0	10,0	83,5	M8x1	MTC-BT040-10-120-3-0-A	30385229
40	10,0	16,0	28,0	160,0	41,0	10,0	114,4	M8x1	MTC-BT040-10-160-3-0-A	30385230
40	10,0	16,0	28,0	200,0	41,0	10,0	114,4	M8x1	MTC-BT040-10-200-3-0-A	30654920
40	12,0	18,0	23,7	90,0	47,0	10,0	53,5	M10x1	MTC-BT040-12-090-3-0-A	30385231
40	12,0	18,0	27,0	120,0	47,0	10,0	85,8	M10x1	MTC-BT040-12-120-3-0-A	30385232
40	12,0	18,0	30,0	160,0	47,0	10,0	114,4	M10x1	MTC-BT040-12-160-3-0-A	30385233
40	12,0	18,0	30,0	200,0	47,0	10,0	114,4	M10x1	MTC-BT040-12-200-3-0-A	30654921
40	14,0	20,0	25,9	90,0	47,0	10,0	55,8	M10x1	MTC-BT040-14-090-3-0-A	30385234
40	14,0	20,0	29,3	120,0	47,0	10,0	88,2	M10x1	MTC-BT040-14-120-3-0-A	30385235
40	14,0	20,0	32,0	160,0	47,0	10,0	114,4	M10x1	MTC-BT040-14-160-3-0-A	30385236
40	14,0	20,0	32,0	200,0	47,0	10,0	114,4	M10x1	MTC-BT040-14-200-3-0-A	30654922
40	16,0	22,0	27,9	90,0	50,0	10,0	55,8	M12x1	MTC-BT040-16-090-3-0-A	30385237
40	16,0	22,0	31,3	120,0	50,0	10,0	88,2	M12x1	MTC-BT040-16-120-3-0-A	30385238
40	16,0	22,0	34,0	160,0	50,0	10,0	114,4	M12x1	MTC-BT040-16-160-3-0-A	30385239
40	16,0	22,0	34,0	200,0	50,0	10,0	114,4	M12x1	MTC-BT040-16-200-3-0-A	30654923
40	18,0	24,0	29,9	90,0	50,0	10,0	55,8	M12x1	MTC-BT040-18-090-3-0-A	30385240
40	18,0	24,0	33,5	120,0	50,0	10,0	90,6	M12x1	MTC-BT040-18-120-3-0-A	30385241
40	18,0	24,0	36,0	160,0	50,0	10,0	114,4	M12x1	MTC-BT040-18-160-3-0-A	30385242
40	18,0	24,0	36,0	200,0	50,0	10,0	114,4	M12x1	MTC-BT040-18-200-3-0-A	30654924

ThermoChuck | With axial tool length adjustment | BT shank as per ISO 7388-2 Form JD/JF (JIS B 6339)

BT	Dimensions							G	Specification	Order no.
	d ₁	d ₂	d ₃	l ₁	l ₂	l ₃	l ₄			
40	20,0	26,0	32,2	90,0	52,0	10,0	58,2	M16x1	MTC-BT040-20-090-3-0-A	30385243
40	20,0	26,0	35,5	120,0	52,0	10,0	90,6	M16x1	MTC-BT040-20-120-3-0-A	30385244
40	20,0	26,0	38,0	160,0	52,0	10,0	114,4	M16x1	MTC-BT040-20-160-3-0-A	30385245
40	20,0	26,0	38,0	200,0	52,0	10,0	114,4	M16x1	MTC-BT040-20-200-3-0-A	30654925

* Without axial tool length adjustment.

Dimensions in mm.

Additional dimensions available upon request.

Scope of delivery: With built-in, drilled through length adjustment screw. Without fine balancing screws or pull studs.

Design: Permissible run-out variation on the taper shank in relation to the clamping diameter d₁ = 3 µm. The clamping diameter is designed for a shank tolerance of h6. Basic set-

ting Form JD; if Form JF is required, please state with the order.

Note: For pull stud, see section "Accessories, spare parts and measuring equipment".

Length adjustment screws and fine balancing screws available on request.

Balancing quality: G 2.5 with 25,000 rpm in delivery status.

Shrink chuck ThermoChuck

With axial tool length adjustment

Shank hollow shank taper E according to DIN 69893-5

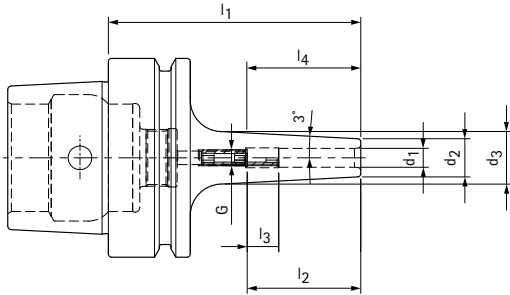

Available upon request | Slim design 3°

HSK-E	Dimensions							G	Specification	Order no.
	d_1	d_2	d_3	l_1	l_2	l_3	l_4			
40	3,0	9,0	13,0	60,0	28,0	16,0	39,1	M6	MTC-HSK-E040-03-060-1-0-A	30551131
40	4,0	10,0	14,0	60,0	28,0	12,0	39,1	M6	MTC-HSK-E040-04-060-1-0-A	30551134
40	5,0	11,0	15,0	60,0	30,0	10,0	39,1	M6	MTC-HSK-E040-05-060-1-0-A	30551137
40	6,0	12,0	16,0	60,0	36,0	10,0	39,1	M5	MTC-HSK-E040-06-060-1-0-A	30551140
40	8,0	14,0	18,0	60,0	36,0	10,0	39,1	M5	MTC-HSK-E040-08-060-1-0-A	30551143
40	10,0	16,0	20,0	60,0	38,0	7,0	39,1	M5	MTC-HSK-E040-10-060-1-0-A	30551146
40	12,0	18,0	22,0	60,0	40,0	3,0	39,1	M5	MTC-HSK-E040-12-060-1-0-A	30551149
50	3,0	9,0	14,0	70,0	28,0	16,0	43,1	M6	MTC-HSK-E050-03-070-1-0-A	30551152
50	4,0	10,0	15,0	70,0	28,0	12,0	43,1	M6	MTC-HSK-E050-04-070-1-0-A	30551155
50	5,0	11,0	16,0	70,0	30,0	10,0	43,1	M6	MTC-HSK-E050-05-070-1-0-A	30551158
50	6,0	12,0	17,0	70,0	36,0	10,0	43,1	M5	MTC-HSK-E050-06-070-1-0-A	30551161
50	8,0	14,0	19,0	70,0	36,0	10,0	43,1	M5	MTC-HSK-E050-08-070-1-0-A	30551164
50	10,0	16,0	21,0	70,0	41,0	10,0	43,1	M5	MTC-HSK-E050-10-070-1-0-A	30551167
50	12,0	18,0	23,0	70,0	44,0	7,0	43,1	M5	MTC-HSK-E050-12-070-1-0-A	30551170

Dimensions in mm.

Scope of delivery: With built-in, drilled through length adjustment screw. Without fine balancing screws and coolant tube.

Design: Permissible run-out variation on the hollow taper shank in relation to the clamping diameter $d_1 = 3 \mu\text{m}$. The clamping diameter is designed for a shank tolerance of h6.

Note: You will find tool extensions in the section "Chucks with cylindrical shank".

Fine balancing screws on request. You will find information on the coding system in the "Technical appendix".

Balancing quality: G 2.5 with 25,000 rpm in delivery status.

ThermoChuck

In accordance with DIN 69882-8 with axial tool length adjustment
 HSK-A (hollow shank taper form A) shank according to DIN 69893-1

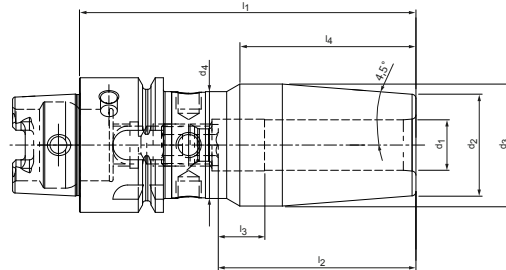
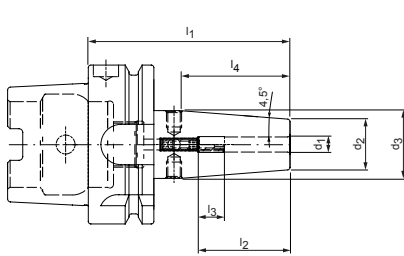

HSK-A	Dimensions								G	Specification	Order no.
	d ₁	d ₂	d ₃	d ₄	l ₁	l ₂	l ₃	l ₄			
32	3,0	10,0	15,0	-	60,0	28,0	16,0	31,7	M5	MTC-HSK-A032-03-060-1-0-A	30261650
32	4,0	10,0	15,0	-	60,0	28,0	12,0	31,7	M5	MTC-HSK-A032-04-060-1-0-A	30261651
32	5,0	10,0	15,0	-	60,0	30,0	10,0	31,7	M6	MTC-HSK-A032-05-060-1-0-A	30261652
32	6,0	21,0	25,0	-	70,0	36,0	10,0	25,4	M5	MTC-HSK-A032-06-070-1-0-A	30261653
32	8,0	21,0	25,0	-	70,0	36,0	10,0	25,4	M6	MTC-HSK-A032-08-070-1-0-A	30261654
32	10,0	24,0	29,0	25,4	75,0	41,0	10,0	37,0	M8x1	MTC-HSK-A032-10-075-1-0-A	30261655
32	12,0	24,0	29,0	25,4	80,0	47,0	10,0	42,0	M10x1	MTC-HSK-A032-12-080-1-0-A	30261656
40	3,0	10,0	15,0	-	60,0	28,0	16,0	39,1	M6	MTC-HSK-A040-03-060-1-0-A	30261657
40	4,0	10,0	15,0	-	60,0	28,0	12,0	39,1	M6	MTC-HSK-A040-04-060-1-0-A	30258468
40	5,0	10,0	15,0	-	60,0	30,0	10,0	39,1	M6	MTC-HSK-A040-05-060-1-0-A	30261663
40	6,0	21,0	27,0	-	80,0	36,0	10,0	38,1	M5	MTC-HSK-A040-06-080-1-0-A	30261666
40	8,0	21,0	27,0	-	80,0	36,0	10,0	38,1	M6	MTC-HSK-A040-08-080-1-0-A	30261669
40	10,0	24,0	32,0	-	80,0	41,0	10,0	50,0	M8x1	MTC-HSK-A040-10-080-1-0-A	30261672
40	12,0	24,0	32,0	-	90,0	47,0	10,0	50,8	M10x1	MTC-HSK-A040-12-090-1-0-A	30261675
40	14,0	27,0	33,5	-	90,0	47,0	10,0	41,2	M10x1	MTC-HSK-A040-14-090-1-0-A	30261678
40	16,0	27,0	33,5	-	90,0	50,0	10,0	41,2	M12x1	MTC-HSK-A040-16-090-1-0-A	30261681
50	3,0	10,0	15,0	-	80,0	28,0	16,0	31,7	M6	MTC-HSK-A050-03-080-1-0-A	30261684
50	4,0	15,0	22,0	-	80,0	28,0	12,0	44,4	M6	MTC-HSK-A050-04-080-1-0-A	30261687
50	5,0	15,0	22,0	-	80,0	30,0	10,0	44,4	M6	MTC-HSK-A050-05-080-1-0-A	30261690
50	6,0	21,0	27,0	-	80,0	36,0	10,0	38,1	M5	MTC-HSK-A050-06-080-1-0-A	30259972
50	8,0	21,0	27,0	-	80,0	36,0	10,0	38,1	M6	MTC-HSK-A050-08-080-1-0-A	30261696
50	10,0	24,0	32,0	-	85,0	41,0	10,0	50,8	M8x1	MTC-HSK-A050-10-085-1-0-A	30261699
50	12,0	24,0	32,0	-	90,0	47,0	10,0	50,8	M10x1	MTC-HSK-A050-12-090-1-0-A	30261702
50	14,0	27,0	34,0	-	90,0	47,0	10,0	44,4	M10x1	MTC-HSK-A050-14-090-1-0-A	30261705
50	16,0	27,0	34,0	-	95,0	50,0	10,0	44,4	M12x1	MTC-HSK-A050-16-095-1-0-A	30261708
50	18,0	33,0	41,5	-	95,0	50,0	10,0	54,0	M12x1	MTC-HSK-A050-18-095-1-0-A	30261712
50	20,0	33,0	41,5	-	100,0	52,0	10,0	54,0	M16x1	MTC-HSK-A050-20-100-1-0-A	30261715
63	3,0	10,0	15,0	-	80,0	28,0	16,0	31,7	M6	MTC-HSK-A063-03-080-1-0-A	30261718
63*	3,0	10,0	20,0	-	120,0	12,0	-	63,5	-	MTC-HSK-A063-03-120-1-0-W	30261731
63*	3,0	10,0	20,0	-	130,0	12,0	-	63,5	-	MTC-HSK-A063-03-130-1-0-W	30872496
63	4,0	15,0	22,0	-	80,0	28,0	12,0	44,4	M6	MTC-HSK-A063-04-080-1-0-A	30260639
63*	4,0	15,0	22,0	-	120,0	16,0	-	44,4	-	MTC-HSK-A063-04-120-1-0-W	30261733
63*	4,0	15,0	22,0	-	130,0	16,0	-	44,4	-	MTC-HSK-A063-04-130-1-0-W	30872497
63	5,0	15,0	22,0	-	80,0	30,0	10,0	44,4	M6	MTC-HSK-A063-05-080-1-0-A	30261720
63*	5,0	15,0	22,0	-	120,0	20,0	-	44,4	-	MTC-HSK-A063-05-120-1-0-W	30261735
63*	5,0	15,0	22,0	-	130,0	20,0	-	44,4	-	MTC-HSK-A063-05-130-1-0-W	30872498
63	6,0	21,0	27,0	-	80,0	36,0	10,0	38,1	M5	MTC-HSK-A063-06-080-1-0-A	30261721
63	6,0	21,0	27,0	-	120,0	36,0	10,0	38,1	M5	MTC-HSK-A063-06-120-1-0-A	30261737
63	6,0	21,0	27,0	-	130,0	36,0	10,0	38,1	M5	MTC-HSK-A063-06-130-1-0-A	30872499

Continued on next page.

ThermoChuck | as per DIN 69882-8 | with axial tool length adjustment | Hollow shank taper form A shank as per DIN 69893-1

HSK-A	Dimensions								G	Specification	Order no.
	d ₁	d ₂	d ₃	d ₄	l ₁	l ₂	l ₃	l ₄			
63	6,0	21,0	27,0	-	160,0	36,0	10,0	38,1	M5	MTC-HSK-A063-06-160-1-0-A	30261738
63	6,0	21,0	27,0	-	200,0	36,0	10,0	38,1	M5	MTC-HSK-A063-06-200-1-0-A	30529026
63	8,0	21,0	27,0	-	80,0	36,0	10,0	38,1	M6	MTC-HSK-A063-08-080-1-0-A	30261722
63	8,0	21,0	27,0	-	120,0	36,0	10,0	38,1	M6	MTC-HSK-A063-08-120-1-0-A	30261739
63	8,0	21,0	27,0	-	130,0	36,0	10,0	38,1	M6	MTC-HSK-A063-08-130-1-0-A	30872500
63	8,0	21,0	27,0	-	160,0	36,0	10,0	38,1	M6	MTC-HSK-A063-08-160-1-0-A	30261740
63	8,0	21,0	27,0	-	200,0	36,0	10,0	38,1	M6	MTC-HSK-A063-08-200-1-0-A	30488595
63	10,0	24,0	32,0	-	85,0	41,0	10,0	50,8	M8x1	MTC-HSK-A063-10-085-1-0-A	30261723
63	10,0	24,0	32,0	-	120,0	41,0	10,0	50,8	M8x1	MTC-HSK-A063-10-120-1-0-A	30261741
63	10,0	24,0	32,0	-	130,0	41,0	10,0	50,8	M8x1	MTC-HSK-A063-10-130-1-0-A	30872501
63	10,0	24,0	32,0	-	160,0	41,0	10,0	50,8	M8x1	MTC-HSK-A063-10-160-1-0-A	30261742
63	10,0	24,0	32,0	-	200,0	41,0	10,0	50,8	M8x1	MTC-HSK-A063-10-200-1-0-A	30529032
63	12,0	24,0	32,0	-	90,0	47,0	10,0	50,8	M10x1	MTC-HSK-A063-12-090-1-0-A	30261724
63	12,0	24,0	32,0	-	120,0	47,0	10,0	50,8	M10x1	MTC-HSK-A063-12-120-1-0-A	30261743
63	12,0	24,0	32,0	-	130,0	47,0	10,0	50,8	M10x1	MTC-HSK-A063-12-130-1-0-A	30872502
63	12,0	24,0	32,0	-	160,0	47,0	10,0	50,8	M10x1	MTC-HSK-A063-12-160-1-0-A	30259973
63	12,0	24,0	32,0	-	200,0	47,0	10,0	50,8	M10x1	MTC-HSK-A063-12-200-1-0-A	30529033
63	14,0	27,0	34,0	-	90,0	47,0	10,0	44,4	M10x1	MTC-HSK-A063-14-090-1-0-A	30261725
63	14,0	27,0	34,0	-	120,0	47,0	10,0	44,4	M10x1	MTC-HSK-A063-14-120-1-0-A	30261745
63	14,0	27,0	34,0	-	130,0	47,0	10,0	44,4	M10x1	MTC-HSK-A063-14-130-1-0-A	30872503
63	14,0	27,0	34,0	-	160,0	47,0	10,0	44,4	M10x1	MTC-HSK-A063-14-160-1-0-A	30261746
63	14,0	27,0	34,0	-	200,0	47,0	10,0	44,4	M10x1	MTC-HSK-A063-14-200-1-0-A	30529043
63	16,0	27,0	34,0	-	95,0	50,0	10,0	44,4	M12x1	MTC-HSK-A063-16-095-1-0-A	30261726
63	16,0	27,0	34,0	-	120,0	50,0	10,0	44,4	M12x1	MTC-HSK-A063-16-120-1-0-A	30261747
63	16,0	27,0	34,0	-	130,0	50,0	10,0	44,4	M12x1	MTC-HSK-A063-16-130-1-0-A	30872504
63	16,0	27,0	34,0	-	160,0	50,0	10,0	44,4	M12x1	MTC-HSK-A063-16-160-1-0-A	30261748
63	16,0	27,0	34,0	-	200,0	50,0	10,0	44,4	M12x1	MTC-HSK-A063-16-200-1-0-A	30529044
63	18,0	33,0	42,0	-	95,0	50,0	10,0	57,1	M12x1	MTC-HSK-A063-18-095-1-0-A	30261727
63	18,0	33,0	42,0	-	120,0	50,0	10,0	57,1	M12x1	MTC-HSK-A063-18-120-1-0-A	30261749
63	18,0	33,0	42,0	-	130,0	50,0	10,0	57,1	M12x1	MTC-HSK-A063-18-130-1-0-A	30872505
63	18,0	33,0	42,0	-	160,0	50,0	10,0	57,1	M12x1	MTC-HSK-A063-18-160-1-0-A	30261750
63	18,0	33,0	42,0	-	200,0	50,0	10,0	57,1	M12x1	MTC-HSK-A063-18-200-1-0-A	30529045
63	20,0	33,0	42,0	-	100,0	52,0	10,0	57,1	M16x1	MTC-HSK-A063-20-100-1-0-A	30261728
63	20,0	33,0	42,0	-	120,0	52,0	10,0	57,1	M16x1	MTC-HSK-A063-20-120-1-0-A	30261751
63	20,0	33,0	42,0	-	130,0	52,0	10,0	57,1	M16x1	MTC-HSK-A063-20-130-1-0-A	30872506
63	20,0	33,0	42,0	-	160,0	52,0	10,0	57,1	M16x1	MTC-HSK-A063-20-160-1-0-A	30261752
63	20,0	33,0	42,0	-	200,0	52,0	10,0	57,1	M16x1	MTC-HSK-A063-20-200-1-0-A	30529046
63	25,0	44,0	52,5	-	115,0	58,0	10,0	54,0	M16x1	MTC-HSK-A063-25-115-1-0-A	30261729
63	25,0	44,0	52,5	-	120,0	58,0	10,0	54,0	M16x1	MTC-HSK-A063-25-120-1-0-A	30261753
63	25,0	44,0	52,5	-	130,0	58,0	10,0	54,0	M16x1	MTC-HSK-A063-25-130-1-0-A	30872507
63	25,0	44,0	52,5	-	160,0	58,0	10,0	54,0	M16x1	MTC-HSK-A063-25-160-1-0-A	30261754
63	25,0	44,0	52,5	-	200,0	58,0	10,0	54,0	M16x1	MTC-HSK-A063-25-200-1-0-A	30529047
63	32,0	44,0	52,5	-	120,0	62,0	10,0	54,0	M16x1	MTC-HSK-A063-32-120-1-0-A	30261730
63	32,0	44,0	52,5	-	130,0	62,0	10,0	54,0	M16x1	MTC-HSK-A063-32-130-1-0-A	30872508
63	32,0	44,0	52,5	-	160,0	62,0	10,0	54,0	M16x1	MTC-HSK-A063-32-160-1-0-A	30261755
63	32,0	44,0	52,5	-	200,0	62,0	10,0	54,0	M16x1	MTC-HSK-A063-32-200-1-0-A	30529048
80	6,0	21,0	27,0	-	85,0	36,0	10,0	38,1	M5	MTC-HSK-A080-06-085-1-0-A	30261756
80	8,0	21,0	27,0	-	85,0	36,0	10,0	38,1	M6	MTC-HSK-A080-08-085-1-0-A	30261759
80	10,0	24,0	32,0	-	90,0	41,0	10,0	49,3	M8x1	MTC-HSK-A080-10-090-1-0-A	30261762
80	12,0	24,0	32,0	-	95,0	47,0	10,0	50,8	M10x1	MTC-HSK-A080-12-095-1-0-A	30261765
80	14,0	27,0	34,0	-	95,0	47,0	10,0	44,4	M10x1	MTC-HSK-A080-14-095-1-0-A	30261768
80	16,0	27,0	34,0	-	100,0	50,0	10,0	44,4	M12x1	MTC-HSK-A080-16-100-1-0-A	30261771
80	18,0	33,0	42,0	-	100,0	50,0	10,0	57,1	M12x1	MTC-HSK-A080-18-100-1-0-A	30261774
80	20,0	33,0	42,0	-	105,0	52,0	10,0	57,1	M16x1	MTC-HSK-A080-20-105-1-0-A	30261777
80	25,0	44,0	53,0	-	115,0	58,0	10,0	57,1	M16x1	MTC-HSK-A080-25-115-1-0-A	30261780
80	32,0	44,0	53,0	-	120,0	62,0	10,0	57,1	M16x1	MTC-HSK-A080-32-120-1-0-A	30261783
100	6,0	21,0	27,0	-	85,0	36,0	10,0	38,1	M5	MTC-HSK-A100-06-085-1-0-A	30261785

ThermoChuck | as per DIN 69882-8 | with axial tool length adjustment | Hollow shank taper form A shank as per DIN 69893-1

HSK-A	Dimensions								G	Specification	Order no.
	d ₁	d ₂	d ₃	d ₄	l ₁	l ₂	l ₃	l ₄			
100	6,0	21,0	27,0	-	120,0	36,0	10,0	38,1	M5	MTC-HSK-A100-06-120-1-0-A	30261786
100	6,0	21,0	27,0	-	130,0	36,0	10,0	38,1	M5	MTC-HSK-A100-06-130-1-0-A	30872509
100	6,0	21,0	27,0	-	160,0	36,0	10,0	38,1	M5	MTC-HSK-A100-06-160-1-0-A	30261787
100	6,0	21,0	27,0	-	200,0	36,0	10,0	38,1	M5	MTC-HSK-A100-06-200-1-0-A	30558360
100	8,0	21,0	27,0	-	85,0	36,0	10,0	38,1	M6	MTC-HSK-A100-08-085-1-0-A	30261788
100	8,0	21,0	27,0	-	120,0	36,0	10,0	38,1	M6	MTC-HSK-A100-08-120-1-0-A	30261789
100	8,0	21,0	27,0	-	130,0	36,0	10,0	38,1	M6	MTC-HSK-A100-08-130-1-0-A	30872510
100	8,0	21,0	27,0	-	160,0	36,0	10,0	38,1	M6	MTC-HSK-A100-08-160-1-0-A	30261790
100	8,0	21,0	27,0	-	200,0	36,0	10,0	38,1	M6	MTC-HSK-A100-08-200-1-0-A	30558361
100	10,0	24,0	32,0	-	90,0	41,0	10,0	48,9	M8x1	MTC-HSK-A100-10-090-1-0-A	30261791
100	10,0	24,0	32,0	-	120,0	41,0	10,0	50,8	M8x1	MTC-HSK-A100-10-120-1-0-A	30261792
100	10,0	24,0	32,0	-	130,0	41,0	10,0	50,8	M8x1	MTC-HSK-A100-10-130-1-0-A	30872511
100	10,0	24,0	32,0	-	160,0	41,0	10,0	50,8	M8x1	MTC-HSK-A100-10-160-1-0-A	30261793
100	10,0	24,0	32,0	-	200,0	41,0	10,0	50,8	M8x1	MTC-HSK-A100-10-200-1-0-A	30558363
100	12,0	24,0	32,0	-	95,0	47,0	10,0	50,6	M10x1	MTC-HSK-A100-12-095-1-0-A	30261794
100	12,0	24,0	32,0	-	120,0	47,0	10,0	50,8	M10x1	MTC-HSK-A100-12-120-1-0-A	30261795
100	12,0	24,0	32,0	-	130,0	47,0	10,0	50,8	M10x1	MTC-HSK-A100-12-130-1-0-A	30872512
100	12,0	24,0	32,0	-	160,0	47,0	10,0	50,8	M10x1	MTC-HSK-A100-12-160-1-0-A	30261796
100	12,0	24,0	32,0	-	200,0	47,0	10,0	50,8	M10x1	MTC-HSK-A100-12-200-1-0-A	30558364
100	14,0	27,0	34,0	-	95,0	47,0	10,0	44,4	M10x1	MTC-HSK-A100-14-095-1-0-A	30261797
100	14,0	27,0	34,0	-	120,0	47,0	10,0	44,4	M10x1	MTC-HSK-A100-14-120-1-0-A	30261798
100	14,0	27,0	34,0	-	130,0	47,0	10,0	44,4	M10x1	MTC-HSK-A100-14-130-1-0-A	30872513
100	14,0	27,0	34,0	-	160,0	47,0	10,0	44,4	M10x1	MTC-HSK-A100-14-160-1-0-A	30261799
100	14,0	27,0	34,0	-	200,0	47,0	10,0	44,4	M10x1	MTC-HSK-A100-14-200-1-0-A	30558366
100	16,0	27,0	34,0	-	100,0	50,0	10,0	44,4	M12x1	MTC-HSK-A100-16-100-1-0-A	30261800
100	16,0	27,0	34,0	-	120,0	50,0	10,0	44,4	M12x1	MTC-HSK-A100-16-120-1-0-A	30261801
100	16,0	27,0	34,0	-	130,0	50,0	10,0	44,4	M12x1	MTC-HSK-A100-16-130-1-0-A	30872514
100	16,0	27,0	34,0	-	160,0	50,0	10,0	44,4	M12x1	MTC-HSK-A100-16-160-1-0-A	30261802
100	16,0	27,0	34,0	-	200,0	50,0	10,0	44,4	M12x1	MTC-HSK-A100-16-200-1-0-A	30558367
100	18,0	33,0	42,0	-	100,0	50,0	10,0	55,2	M12x1	MTC-HSK-A100-18-100-1-0-A	30261803
100	18,0	33,0	42,0	-	120,0	50,0	10,0	57,1	M12x1	MTC-HSK-A100-18-120-1-0-A	30261804
100	18,0	33,0	42,0	-	130,0	50,0	10,0	57,1	M12x1	MTC-HSK-A100-18-130-1-0-A	30872515
100	18,0	33,0	42,0	-	160,0	50,0	10,0	57,1	M12x1	MTC-HSK-A100-18-160-1-0-A	30261805
100	18,0	33,0	42,0	-	200,0	50,0	10,0	57,1	M12x1	MTC-HSK-A100-18-200-1-0-A	30558368
100	20,0	33,0	42,0	-	105,0	52,0	10,0	57,1	M16x1	MTC-HSK-A100-20-105-1-0-A	30259975
100	20,0	33,0	42,0	-	120,0	52,0	10,0	57,1	M16x1	MTC-HSK-A100-20-120-1-0-A	30261807
100	20,0	33,0	42,0	-	130,0	52,0	10,0	57,1	M16x1	MTC-HSK-A100-20-130-1-0-A	30872516
100	20,0	33,0	42,0	-	160,0	52,0	10,0	57,1	M16x1	MTC-HSK-A100-20-160-1-0-A	30261808
100	20,0	33,0	42,0	-	200,0	52,0	10,0	57,1	M16x1	MTC-HSK-A100-20-200-1-0-A	30558369
100	25,0	44,0	53,0	-	115,0	58,0	10,0	57,1	M16x1	MTC-HSK-A100-25-115-1-0-A	30261809
100	25,0	44,0	53,0	-	120,0	58,0	10,0	57,1	M16x1	MTC-HSK-A100-25-120-1-0-A	30261810
100	25,0	44,0	53,0	-	130,0	58,0	10,0	57,1	M16x1	MTC-HSK-A100-25-130-1-0-A	30872517
100	25,0	44,0	53,0	-	160,0	58,0	10,0	57,1	M16x1	MTC-HSK-A100-25-160-1-0-A	30261811
100	25,0	44,0	53,0	-	200,0	58,0	10,0	57,1	M16x1	MTC-HSK-A100-25-200-1-0-A	30558371
100	32,0	44,0	53,0	-	120,0	62,0	10,0	57,1	M16x1	MTC-HSK-A100-32-120-1-0-A	30261812
100	32,0	44,0	53,0	-	130,0	62,0	10,0	57,1	M16x1	MTC-HSK-A100-32-130-1-0-A	30872518
100	32,0	44,0	53,0	-	160,0	62,0	10,0	57,1	M16x1	MTC-HSK-A100-32-160-1-0-A	30261813
100	32,0	44,0	53,0	-	200,0	62,0	10,0	57,1	M16x1	MTC-HSK-A100-32-200-1-0-A	30558372

* Without axial tool length adjustment.

Dimensions in mm.

Additional dimensions available upon request.

Scope of delivery: With built-in, drilled through length adjustment screw. Without fine balancing screws and coolant tube.

Design: Permissible run-out variation of the hollow taper shank to the clamping diameter $d_1 = 3 \mu\text{m}$. The clamping diameter is designed for a shank tolerance of h6.

Note: Coolant tube and code carrier, see section "Accessories, spare parts and measuring equipment". Length adjustment screws and fine balancing screws available on request.

For notes on coding system, see section "Technical appendix".

Balancing quality: G 2.5 with 25,000 rpm in delivery status.

ThermoChuck

With axial tool length adjustment

SK shank according to ISO 7388-1 Form AD/AF

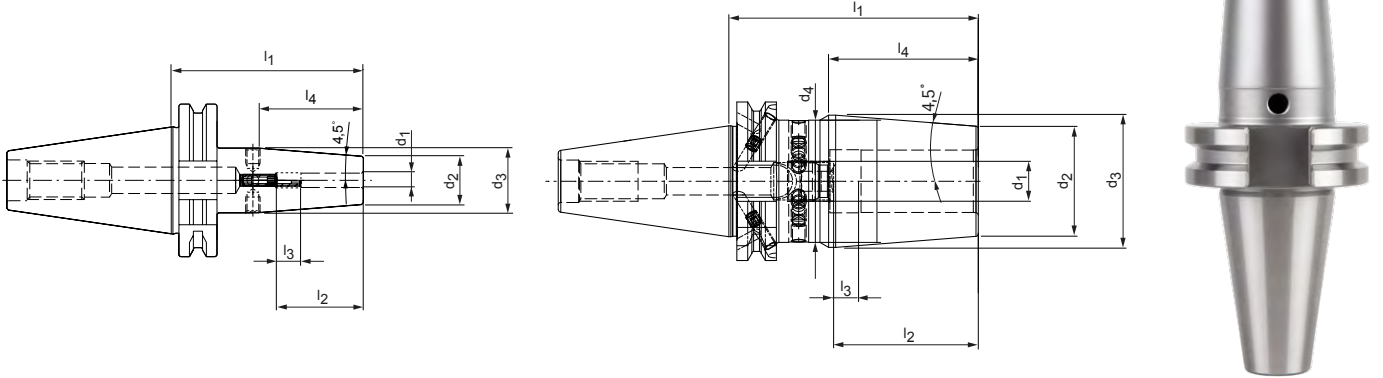

Steep taper	Dimensions								G	Specification	Order no.
	d ₁	d ₂	d ₃	d ₄	l ₁	l ₂	l ₃	l ₄			
30*	3,0	10,0	17,0	-	80,0	28,0	16,0	44,4	M6	MTC-SK030-03-080-1-0-A	30261560
30*	4,0	15,0	22,0	-	80,0	28,0	12,0	44,4	M6	MTC-SK030-04-080-1-0-A	30261561
30*	5,0	15,0	22,0	-	80,0	30,0	10,0	44,4	M6	MTC-SK030-05-080-1-0-A	30261562
30*	6,0	21,0	27,0	-	80,0	36,0	10,0	38,1	M5	MTC-SK030-06-080-1-0-A	30261563
30*	8,0	21,0	27,0	-	80,0	36,0	10,0	38,1	M6	MTC-SK030-08-080-1-0-A	30261564
30*	10,0	24,0	32,0	-	80,0	41,0	10,0	50,8	M8x1	MTC-SK030-10-080-1-0-A	30261565
30*	12,0	24,0	32,0	-	80,0	47,0	10,0	50,8	M10x1	MTC-SK030-12-080-1-0-A	30261566
30*	14,0	27,0	34,0	-	80,0	47,0	10,0	44,4	M10x1	MTC-SK030-14-080-1-0-A	30261567
30*	16,0	27,0	34,0	-	80,0	50,0	10,0	44,4	M12x1	MTC-SK030-16-080-1-0-A	30261568
30*	18,0	33,0	42,0	-	80,0	50,0	10,0	55,2	M12x1	MTC-SK030-18-080-1-0-A	30261569
30*	20,0	33,0	42,0	-	80,0	52,0	10,0	55,2	M16x1	MTC-SK030-20-080-1-0-A	30261570
40	3,0	10,0	17,0	-	80,0	28,0	16,0	44,4	M6	MTC-SK040-03-080-3-0-A	30261571
40**	3,0	10,0	20,0	-	120,0	12,0	-	63,5	-	MTC-SK040-03-120-3-0-W	30261584
40**	3,0	10,0	20,0	-	130,0	12,0	-	63,5	-	MTC-SK040-03-130-3-0-W	30872519
40	4,0	15,0	22,0	-	80,0	28,0	12,0	44,4	M6	MTC-SK040-04-080-3-0-A	30261572
40**	4,0	15,0	22,0	-	120,0	16,0	-	44,4	-	MTC-SK040-04-120-3-0-W	30261586
40**	4,0	15,0	22,0	-	130,0	16,0	-	44,4	-	MTC-SK040-04-130-3-0-W	30872520
40	5,0	15,0	22,0	-	80,0	30,0	10,0	44,4	M6	MTC-SK040-05-080-3-0-A	30261573
40**	5,0	15,0	22,0	-	120,0	20,0	-	44,4	-	MTC-SK040-05-120-3-0-W	30261588
40	5,0	15,0	22,0	-	130,0	20,0	0,0	44,4	-	MTC-SK040-05-130-3-0-W	30872521
40	6,0	21,0	27,0	-	80,0	36,0	10,0	38,1	M5	MTC-SK040-06-080-3-0-A	30261574
40	6,0	21,0	27,0	-	120,0	36,0	10,0	38,1	M5	MTC-SK040-06-120-3-0-A	30261590
40	6,0	21,0	27,0	-	130,0	36,0	10,0	38,1	M5	MTC-SK040-06-130-3-0-A	30872522
40	6,0	21,0	27,0	-	160,0	36,0	10,0	38,1	M5	MTC-SK040-06-160-3-0-A	30261591
40	6,0	21,0	27,0	-	200,0	36,0	10,0	38,1	M5	MTC-SK040-06-200-3-0-A	30655715
40	8,0	21,0	27,0	-	80,0	36,0	10,0	38,1	M6	MTC-SK040-08-080-3-0-A	30261575
40	8,0	21,0	27,0	-	120,0	36,0	10,0	38,1	M6	MTC-SK040-08-120-3-0-A	30261592
40	8,0	21,0	27,0	-	130,0	36,0	10,0	38,1	M6	MTC-SK040-08-130-3-0-A	30872523
40	8,0	21,0	27,0	-	160,0	36,0	10,0	38,1	M6	MTC-SK040-08-160-3-0-A	30261593
40	8,0	21,0	27,0	-	200,0	36,0	10,0	38,1	M6	MTC-SK040-08-200-3-0-A	30655716
40	10,0	24,0	32,0	-	80,0	41,0	10,0	50,8	M8x1	MTC-SK040-10-080-3-0-A	30261576
40	10,0	24,0	32,0	-	120,0	41,0	10,0	50,8	M8x1	MTC-SK040-10-120-3-0-A	30261594
40	10,0	24,0	32,0	-	130,0	41,0	10,0	50,8	M8x1	MTC-SK040-10-130-3-0-A	30872524
40	10,0	24,0	32,0	-	160,0	41,0	10,0	50,8	M8x1	MTC-SK040-10-160-3-0-A	30261595
40	10,0	24,0	32,0	-	200,0	41,0	10,0	50,8	M8x1	MTC-SK040-10-200-3-0-A	30655717
40	12,0	24,0	32,0	-	80,0	47,0	10,0	50,8	M10x1	MTC-SK040-12-080-3-0-A	30261577
40	12,0	24,0	32,0	-	120,0	47,0	10,0	50,8	M10x1	MTC-SK040-12-120-3-0-A	30261596
40	12,0	24,0	32,0	-	130,0	47,0	10,0	50,8	M10x1	MTC-SK040-12-130-3-0-A	30872525
40	12,0	24,0	32,0	-	160,0	47,0	10,0	50,8	M10x1	MTC-SK040-12-160-3-0-A	30261597

ThermoChuck | With axial tool length adjustment | SK shank in accordance ISO 7388-1 Form AD/AF

Steep taper	Dimensions								G	Specification	Order no.
	d ₁	d ₂	d ₃	d ₄	l ₁	l ₂	l ₃	l ₄			
40	12,0	24,0	32,0	-	200,0	47,0	10,0	50,8	M10x1	MTC-SK040-12-200-3-0-A	30655711
40	14,0	27,0	34,0	-	80,0	47,0	10,0	44,4	M10x1	MTC-SK040-14-080-3-0-A	30261578
40	14,0	27,0	34,0	-	120,0	47,0	10,0	44,4	M10x1	MTC-SK040-14-120-3-0-A	30261598
40	14,0	27,0	34,0	-	130,0	47,0	10,0	44,4	M10x1	MTC-SK040-14-130-3-0-A	30872526
40	14,0	27,0	34,0	-	160,0	47,0	10,0	44,4	M10x1	MTC-SK040-14-160-3-0-A	30261599
40	14,0	27,0	34,0	-	200,0	47,0	10,0	44,4	M10x1	MTC-SK040-14-200-3-0-A	30655718
40	16,0	27,0	34,0	-	80,0	50,0	10,0	44,4	M12x1	MTC-SK040-16-080-3-0-A	30261579
40	16,0	27,0	34,0	-	120,0	50,0	10,0	44,4	M12x1	MTC-SK040-16-120-3-0-A	30261600
40	16,0	27,0	34,0	-	130,0	50,0	10,0	44,4	M12x1	MTC-SK040-16-130-3-0-A	30872527
40	16,0	27,0	34,0	-	160,0	50,0	10,0	44,4	M12x1	MTC-SK040-16-160-3-0-A	30261601
40	16,0	27,0	34,0	-	200,0	50,0	10,0	44,4	M12x1	MTC-SK040-16-200-3-0-A	30655719
40	18,0	33,0	42,0	-	80,0	50,0	10,0	58,9	M12x1	MTC-SK040-18-080-3-0-A	30260195
40	18,0	33,0	42,0	-	120,0	50,0	10,0	57,1	M12x1	MTC-SK040-18-120-3-0-A	30261602
40	18,0	33,0	42,0	-	130,0	50,0	10,0	57,1	M12x1	MTC-SK040-18-130-3-0-A	30872528
40	18,0	33,0	42,0	-	160,0	50,0	10,0	57,1	M12x1	MTC-SK040-18-160-3-0-A	30261603
40	18,0	33,0	42,0	-	200,0	50,0	10,0	57,1	M12x1	MTC-SK040-18-200-3-0-A	30655720
40	20,0	33,0	42,0	-	80,0	52,0	10,0	57,2	M16x1	MTC-SK040-20-080-3-0-A	30261581
40	20,0	33,0	42,0	-	120,0	52,0	10,0	57,1	M16x1	MTC-SK040-20-120-3-0-A	30261604
40	20,0	33,0	42,0	-	130,0	52,0	10,0	57,1	M16x1	MTC-SK040-20-130-3-0-A	30872529
40	20,0	33,0	42,0	-	160,0	52,0	10,0	57,1	M16x1	MTC-SK040-20-160-3-0-A	30261605
40	20,0	33,0	42,0	-	200,0	52,0	10,0	57,1	M16x1	MTC-SK040-20-200-3-0-A	30655721
40	25,0	44,0	49,0	53,0	100,0	58,0	10,0	60,0	M16x1	MTC-SK040-25-100-3-0-A	30261582
40	25,0	44,0	53,0	49,0	120,0	58,0	10,0	60,0	M16x1	MTC-SK040-25-120-3-0-A	30261606
40	25,0	44,0	53,0	49,0	130,0	58,0	10,0	70,0	M16x1	MTC-SK040-25-130-3-0-A	30872530
40	25,0	44,0	53,0	49,0	160,0	58,0	10,0	60,0	M16x1	MTC-SK040-25-160-3-0-A	30261607
40	25,0	44,0	53,0	49,0	200,0	58,0	10,0	60,0	M16x1	MTC-SK040-25-200-3-0-A	30655722
40	32,0	44,0	49,0	53,0	100,0	62,0	10,0	60,0	M16x1	MTC-SK040-32-100-3-0-A	30261583
40	32,0	44,0	53,0	49,0	120,0	62,0	10,0	60,0	M16x1	MTC-SK040-32-120-3-0-A	30261608
40	32,0	44,0	53,0	49,0	130,0	62,0	10,0	70,0	M16x1	MTC-SK040-32-130-3-0-A	30872532
40	32,0	44,0	53,0	49,0	160,0	62,0	10,0	60,0	M16x1	MTC-SK040-32-160-3-0-A	30261610
40	32,0	44,0	53,0	49,0	200,0	62,0	10,0	60,0	M16x1	MTC-SK040-32-200-3-0-A	30655723
50**	3,0	10,0	17,0	-	80,0	12,0	-	44,4	-	MTC-SK050-03-080-3-0-W	30261611
50**	3,0	10,0	20,0	-	120,0	12,0	-	63,5	-	MTC-SK050-03-120-3-0-W	30261612
50**	4,0	15,0	22,0	-	80,0	16,0	-	44,4	-	MTC-SK050-04-080-3-0-W	30261614
50**	4,0	15,0	22,0	-	120,0	16,0	-	44,4	-	MTC-SK050-04-120-3-0-W	30261615
50**	5,0	15,0	22,0	-	80,0	20,0	-	44,4	-	MTC-SK050-05-080-3-0-W	30261617
50**	5,0	15,0	22,0	-	120,0	20,0	-	44,4	-	MTC-SK050-05-120-3-0-W	30261618
50	6,0	21,0	27,0	-	80,0	36,0	10,0	38,1	M5	MTC-SK050-06-080-3-0-A	30261620
50	6,0	21,0	27,0	-	120,0	36,0	10,0	38,1	M5	MTC-SK050-06-120-3-0-A	30261621
50	6,0	21,0	27,0	-	160,0	36,0	10,0	38,1	M5	MTC-SK050-06-160-3-0-A	30261622
50	8,0	21,0	27,0	-	80,0	36,0	10,0	38,1	M6	MTC-SK050-08-080-3-0-A	30261623
50	8,0	21,0	27,0	-	120,0	36,0	10,0	38,1	M6	MTC-SK050-08-120-3-0-A	30261624
50	8,0	21,0	27,0	-	160,0	36,0	10,0	38,1	M6	MTC-SK050-08-160-3-0-A	30261625
50	10,0	24,0	32,0	-	80,0	41,0	10,0	50,8	M8x1	MTC-SK050-10-080-3-0-A	30261626
50	10,0	24,0	32,0	-	120,0	41,0	10,0	50,8	M8x1	MTC-SK050-10-120-3-0-A	30261627
50	10,0	24,0	32,0	-	160,0	41,0	10,0	50,8	M8x1	MTC-SK050-10-160-3-0-A	30261628
50	12,0	24,0	32,0	-	80,0	47,0	10,0	50,8	M10x1	MTC-SK050-12-080-3-0-A	30261629
50	12,0	24,0	32,0	-	120,0	47,0	10,0	50,8	M10x1	MTC-SK050-12-120-3-0-A	30261630
50	12,0	24,0	32,0	-	160,0	47,0	10,0	50,8	M10x1	MTC-SK050-12-160-3-0-A	30261631
50	14,0	27,0	34,0	-	80,0	47,0	10,0	44,4	M10x1	MTC-SK050-14-080-3-0-A	30261632
50	14,0	27,0	34,0	-	120,0	47,0	10,0	44,4	M10x1	MTC-SK050-14-120-3-0-A	30261633
50	14,0	27,0	34,0	-	160,0	47,0	10,0	44,4	M10x1	MTC-SK050-14-160-3-0-A	30261634
50	16,0	27,0	34,0	-	80,0	50,0	10,0	44,4	M12x1	MTC-SK050-16-080-3-0-A	30261635
50	16,0	27,0	34,0	-	120,0	50,0	10,0	44,4	M12x1	MTC-SK050-16-120-3-0-A	30261636
50	16,0	27,0	34,0	-	160,0	50,0	10,0	44,4	M12x1	MTC-SK050-16-160-3-0-A	30261637
50	18,0	33,0	42,0	-	80,0	50,0	10,0	55,2	M12x1	MTC-SK050-18-080-3-0-A	30261638
50	18,0	33,0	42,0	-	120,0	50,0	10,0	57,1	M12x1	MTC-SK050-18-120-3-0-A	30261639

Continued on next page.

ThermoChuck | With axial tool length adjustment | SK shank in accordance ISO 7388-1 Form AD/AF

Steep taper	Dimensions								G	Specification	Order no.
	d ₁	d ₂	d ₃	d ₄	l ₁	l ₂	l ₃	l ₄			
50	18,0	33,0	42,0	-	130,0	50,0	10,0	57,1	M12x1	MTC-SK050-18-130-3-0-A	30872533
50	18,0	33,0	42,0	-	160,0	50,0	10,0	57,1	M12x1	MTC-SK050-18-160-3-0-A	30261640
50	20,0	33,0	42,0	-	80,0	52,0	10,0	55,2	M16x1	MTC-SK050-20-080-3-0-A	30261641
50	20,0	33,0	42,0	-	120,0	52,0	10,0	57,1	M16x1	MTC-SK050-20-120-3-0-A	30261642
50	20,0	33,0	42,0	-	130,0	52,0	10,0	57,1	M16x1	MTC-SK050-20-130-3-0-A	30872534
50	20,0	33,0	42,0	-	160,0	52,0	10,0	57,1	M16x1	MTC-SK050-20-160-3-0-A	30261643
50	25,0	44,0	53,0	-	100,0	58,0	10,0	57,1	M16x1	MTC-SK050-25-100-3-0-A	30261644
50	25,0	44,0	53,0	-	120,0	58,0	10,0	57,1	M16x1	MTC-SK050-25-120-3-0-A	30261645
50	25,0	44,0	53,0	-	130,0	58,0	10,0	57,1	M16x1	MTC-SK050-25-130-3-0-A	30872535
50	25,0	44,0	53,0	-	160,0	58,0	10,0	57,1	M16x1	MTC-SK050-25-160-3-0-A	30261646
50	32,0	44,0	53,0	-	100,0	62,0	10,0	57,1	M16x1	MTC-SK050-32-100-3-0-A	30261647
50	32,0	44,0	53,0	-	120,0	62,0	10,0	57,1	M16x1	MTC-SK050-32-120-3-0-A	30261648
50	32,0	44,0	53,0	-	130,0	62,0	10,0	57,1	M16x1	MTC-SK050-32-130-3-0-A	30872536
50	32,0	44,0	53,0	-	160,0	62,0	10,0	57,1	M16x1	MTC-SK050-32-160-3-0-A	30261649

* Design: Taper shank size is not available in the AD/AF combination design.

** Without axial tool length adjustment.

Dimensions in mm.

Additional dimensions available upon request.

Scope of delivery: With built-in, drilled through length adjustment screw. Without fine balancing screws or pull studs.

Design: Permissible run-out variation on the taper shank in relation to the clamping diameter d₁ = 3 µm. The clamping diameter is designed for a shank tolerance of h6. Basic set-

ting Form AD, if Form AF is required, please specify this when placing your order.

Note: For pull stud, see section "Accessories, spare parts and measuring equipment".

Length adjustment screws and fine balancing screws available on request.

Balancing quality: G 2.5 with 25,000 rpm in delivery status.

ThermoChuck

With axial tool length adjustment

Shank BT according to ISO 7388-2 Form JD/JF (JIS B 6339)

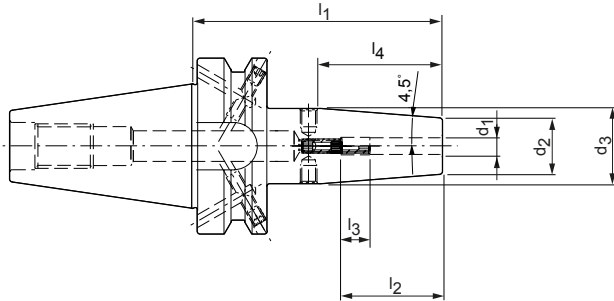

BT	Dimensions							G	Specification	Order no.
	d_1	d_2	d_3	l_1	l_2	l_3	l_4			
30*	3,0	10,0	17,0	85,0	28,0	16,0	44,4	M6	MTC-BT030-03-085-1-0-A	30329402
30*	4,0	15,0	22,0	85,0	28,0	12,0	44,4	M6	MTC-BT030-04-085-1-0-A	30329453
30*	5,0	15,0	22,0	85,0	30,0	10,0	44,4	M6	MTC-BT030-05-085-1-0-A	30329454
30*	6,0	21,0	27,0	85,0	36,0	10,0	38,1	M5	MTC-BT030-06-085-1-0-A	30329455
30*	8,0	21,0	27,0	85,0	36,0	10,0	38,1	M6	MTC-BT030-08-085-1-0-A	30308274
30*	10,0	24,0	32,0	85,0	41,0	10,0	50,8	M8x1	MTC-BT030-10-085-1-0-A	30308275
30*	12,0	24,0	32,0	85,0	47,0	10,0	50,8	M10x1	MTC-BT030-12-085-1-0-A	30325011
30*	14,0	27,0	34,0	85,0	47,0	10,0	44,4	M10x1	MTC-BT030-14-085-1-0-A	30329458
30*	16,0	27,0	34,0	85,0	50,0	10,0	44,4	M12x1	MTC-BT030-16-085-1-0-A	30329447
30*	18,0	33,0	42,0	85,0	50,0	10,0	57,1	M12x1	MTC-BT030-18-085-1-0-A	30329460
30*	20,0	33,0	42,0	85,0	52,0	10,0	57,1	M16x1	MTC-BT030-20-085-1-0-A	30300170
40	3,0	10,0	17,0	90,0	28,0	16,0	44,4	M6	MTC-BT040-03-090-3-0-A	30261814
40**	3,0	10,0	20,0	120,0	12,0	-	63,5	-	MTC-BT040-03-120-3-0-W	30261815
40	4,0	15,0	22,0	90,0	28,0	12,0	44,4	M6	MTC-BT040-04-090-3-0-A	30261817
40**	4,0	15,0	22,0	120,0	16,0	-	44,4	-	MTC-BT040-04-120-3-0-W	30261818
40	5,0	15,0	22,0	90,0	30,0	10,0	44,4	M6	MTC-BT040-05-090-3-0-A	30261820
40**	5,0	15,0	22,0	120,0	20,0	-	44,4	-	MTC-BT040-05-120-3-0-W	30261821
40	6,0	21,0	27,0	90,0	36,0	10,0	38,1	M5	MTC-BT040-06-090-3-0-A	30261823
40	6,0	21,0	27,0	120,0	36,0	10,0	38,1	M5	MTC-BT040-06-120-3-0-A	30261824
40	6,0	21,0	27,0	160,0	36,0	10,0	38,1	M5	MTC-BT040-06-160-3-0-A	30261825
40	8,0	21,0	27,0	90,0	36,0	10,0	38,1	M6	MTC-BT040-08-090-3-0-A	30261826
40	8,0	21,0	27,0	120,0	36,0	10,0	38,1	M6	MTC-BT040-08-120-3-0-A	30261827
40	8,0	21,0	27,0	160,0	36,0	10,0	38,1	M6	MTC-BT040-08-160-3-0-A	30261828
40	10,0	24,0	32,0	90,0	41,0	10,0	50,8	M8x1	MTC-BT040-10-090-3-0-A	30261829
40	10,0	24,0	32,0	120,0	41,0	10,0	50,8	M8x1	MTC-BT040-10-120-3-0-A	30261830
40	10,0	24,0	32,0	160,0	41,0	10,0	50,8	M8x1	MTC-BT040-10-160-3-0-A	30261831
40	12,0	24,0	32,0	90,0	47,0	10,0	50,8	M10x1	MTC-BT040-12-090-3-0-A	30261832
40	12,0	24,0	32,0	120,0	47,0	10,0	44,4	M10x1	MTC-BT040-12-120-3-0-A	30261833
40	12,0	24,0	32,0	160,0	47,0	10,0	44,4	M10x1	MTC-BT040-12-160-3-0-A	30261834
40	14,0	27,0	34,0	90,0	47,0	10,0	44,4	M10x1	MTC-BT040-14-090-3-0-A	30261835
40	14,0	27,0	34,0	120,0	47,0	10,0	44,4	M10x1	MTC-BT040-14-120-3-0-A	30261836
40	14,0	27,0	34,0	160,0	47,0	10,0	44,4	M10x1	MTC-BT040-14-160-3-0-A	30261837
40	16,0	27,0	34,0	90,0	50,0	10,0	44,4	M12x1	MTC-BT040-16-090-3-0-A	30261838
40	16,0	27,0	34,0	120,0	50,0	10,0	44,4	M12x1	MTC-BT040-16-120-3-0-A	30261839
40	16,0	27,0	34,0	160,0	50,0	10,0	44,4	M12x1	MTC-BT040-16-160-3-0-A	30261840
40	18,0	33,0	42,0	90,0	50,0	10,0	55,2	M12x1	MTC-BT040-18-090-3-0-A	30261841
40	18,0	33,0	42,0	120,0	50,0	10,0	57,1	M12x1	MTC-BT040-18-120-3-0-A	30261842
40	18,0	33,0	42,0	160,0	50,0	10,0	57,1	M12x1	MTC-BT040-18-160-3-0-A	30261843
40	20,0	33,0	42,0	90,0	52,0	10,0	55,2	M16x1	MTC-BT040-20-090-3-0-A	30261844

Continued on next page.

ThermoChuck | With axial tool length adjustment | BT shank as per ISO 7388-2 Form JD/JF (JIS B 6339)

BT	Dimensions							G	Specification	Order no.
	d ₁	d ₂	d ₃	l ₁	l ₂	l ₃	l ₄			
40	20,0	33,0	42,0	120,0	52,0	10,0	57,1	M16x1	MTC-BT040-20-120-3-0-A	30261845
40	20,0	33,0	42,0	160,0	52,0	10,0	57,1	M16x1	MTC-BT040-20-160-3-0-A	30261846
40	25,0	44,0	53,0	100,0	58,0	10,0	57,1	M16x1	MTC-BT040-25-100-3-0-A	30261847
40	25,0	44,0	53,0	120,0	58,0	10,0	57,1	M16x1	MTC-BT040-25-120-3-0-A	30261848
40	25,0	44,0	53,0	160,0	58,0	10,0	57,1	M16x1	MTC-BT040-25-160-3-0-A	30261849
40	32,0	44,0	53,0	100,0	62,0	10,0	57,1	M16x1	MTC-BT040-32-100-3-0-A	30261850
40	32,0	44,0	53,0	120,0	62,0	10,0	57,1	M16x1	MTC-BT040-32-120-3-0-A	30261851
40	32,0	44,0	53,0	160,0	62,0	10,0	57,1	M16x1	MTC-BT040-32-160-3-0-A	30261852
50	6,0	21,0	27,0	100,0	36,0	10,0	38,1	M5	MTC-BT050-06-100-3-0-A	30261862
50	8,0	21,0	27,0	100,0	36,0	10,0	38,1	M6	MTC-BT050-08-100-3-0-A	30261865
50	10,0	24,0	32,0	100,0	41,0	10,0	50,8	M8x1	MTC-BT050-10-100-3-0-A	30261868
50	12,0	24,0	32,0	100,0	47,0	10,0	50,8	M10x1	MTC-BT050-12-100-3-0-A	30261871
50	14,0	27,0	34,0	100,0	47,0	10,0	44,4	M10x1	MTC-BT050-14-100-3-0-A	30261874
50	16,0	27,0	34,0	100,0	50,0	10,0	44,4	M12x1	MTC-BT050-16-100-3-0-A	30259977
50	18,0	33,0	42,0	100,0	50,0	10,0	55,2	M12x1	MTC-BT050-18-100-3-0-A	30261880
50	20,0	33,0	42,0	100,0	52,0	10,0	55,2	M16x1	MTC-BT050-20-100-3-0-A	30261883
50	25,0	44,0	53,0	110,0	58,0	10,0	57,1	M16x1	MTC-BT050-25-110-3-0-A	30261886
50	32,0	44,0	53,0	110,0	62,0	10,0	57,1	M16x1	MTC-BT050-32-110-3-0-A	30261889

* Design: Taper shank size BT30 is not available in the JD/JF combination design.

** Without axial tool length adjustment.

Dimensions in mm.

Additional dimensions available upon request.

Scope of delivery: With built-in, drilled through length adjustment screw. Without fine balancing screws or pull studs.

Design: Permissible run-out variation on the taper shank in relation to the clamping diameter d₁ = 3 µm. The clamping diameter is designed for a shank tolerance of h6. Basic set-

ting Form JD; if Form JF is required, please state with the order.

Note: For pull stud, see section "Accessories, spare parts and measuring equipment".

Length adjustment screws and fine balancing screws available on request.

Balancing quality: G 2.5 with 25,000 rpm in delivery status.

ThermoChuck

With axial tool length adjustment
Shank similar to ISO 7388-2 Form JD
(with face connection)

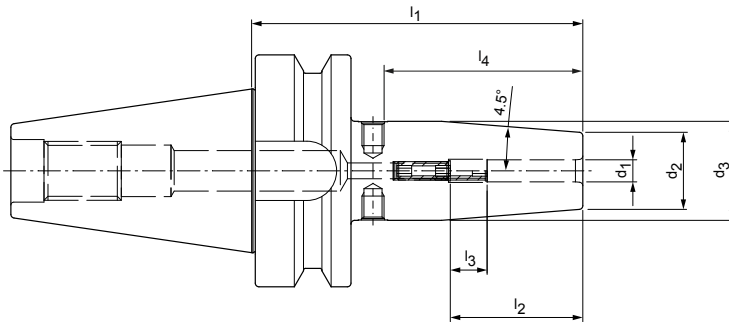

BT-FC	Dimensions							G	Specification	Order no.
	d ₁	d ₂	d ₃	l ₁	l ₂	l ₃	l ₄			
30	3,0	10,0	17,0	85,0	28,0	16,0	44,4	M6X14	MTC-JD-FC030-03-085-1-0-A	30660218
30	4,0	15,0	22,0	85,0	28,0	12,0	44,4	M6X14	MTC-JD-FC030-04-085-1-0-A	30660219
30	5,0	15,0	22,0	85,0	30,0	10,0	44,4	M6X14	MTC-JD-FC030-05-085-1-0-A	30660220
30	6,0	21,0	27,0	85,0	36,0	10,0	38,1	M5	MTC-JD-FC030-06-085-1-0-A	30660221
30	8,0	21,0	27,0	85,0	36,0	10,0	38,1	M6	MTC-JD-FC030-08-085-1-0-A	30660222
30	10,0	24,0	32,0	85,0	41,0	10,0	50,8	M8x1	MTC-JD-FC030-10-085-1-0-A	30660223
30	12,0	24,0	32,0	85,0	47,0	10,0	50,8	M10x1	MTC-JD-FC030-12-085-1-0-A	30660224
30	14,0	27,0	34,0	85,0	47,0	10,0	44,4	M10x1	MTC-JD-FC030-14-085-1-0-A	30660225
30	16,0	27,0	34,0	85,0	50,0	10,0	44,4	M12x1	MTC-JD-FC030-16-085-1-0-A	30660226
30	18,0	33,0	42,0	85,0	50,0	10,0	44,4	M12x1	MTC-JD-FC030-18-085-1-0-A	30660227
30	20,0	33,0	42,0	85,0	52,0	10,0	44,4	M16x1	MTC-JD-FC030-20-085-1-0-A	30660228
40	3,0	10,0	17,0	90,0	28,0	16,0	44,4	M6X14	MTC-JD-FC040-03-090-1-0-A	30660229
40	4,0	15,0	22,0	90,0	28,0	12,0	44,4	M6X14	MTC-JD-FC040-04-090-1-0-A	30660230
40	5,0	15,0	22,0	90,0	30,0	10,0	44,4	M6X14	MTC-JD-FC040-05-090-1-0-A	30660231
40	6,0	21,0	27,0	90,0	36,0	10,0	38,1	M5	MTC-JD-FC040-06-090-1-0-A	30660232
40	8,0	21,0	27,0	90,0	36,0	10,0	38,1	M6	MTC-JD-FC040-08-090-1-0-A	30660233
40	10,0	24,0	32,0	90,0	41,0	10,0	50,8	M8x1	MTC-JD-FC040-10-090-1-0-A	30660234
40	12,0	24,0	32,0	90,0	47,0	10,0	50,8	M10x1	MTC-JD-FC040-12-090-1-0-A	30660235
40	14,0	27,0	34,0	90,0	47,0	10,0	44,4	M10x1	MTC-JD-FC040-14-090-1-0-A	30660236
40	16,0	27,0	34,0	90,0	50,0	10,0	44,4	M12x1	MTC-JD-FC040-16-090-1-0-A	30660237
40	18,0	33,0	42,0	90,0	50,0	10,0	55,2	M12x1	MTC-JD-FC040-18-090-1-0-A	30660238
40	20,0	33,0	42,0	90,0	52,0	10,0	55,2	M16x1	MTC-JD-FC040-20-090-1-0-A	30660239
40	25,0	44,0	53,0	100,0	58,0	10,0	57,1	M16x1	MTC-JD-FC040-25-100-1-0-A	30660240
40	32,0	44,0	53,0	100,0	62,0	10,0	57,1	M16x1	MTC-JD-FC040-32-100-1-0-A	30660241

Dimensions in mm.

Additional dimensions available upon request.

Scope of delivery: With built-in, drilled through length adjustment screw. Without fine balancing screws or pull studs.

Design: Permissible run-out variation on the taper shank in relation to the clamping diameter $d_1 = 3 \mu\text{m}$. The clamping diameter is designed for a shank tolerance of h6.

Note: For pull stud, see section "Accessories, spare parts and measuring equipment".

Length adjustment screws and fine balancing screws available on request.

Balancing quality: G 2.5 with 25,000 rpm in delivery status.

ThermoChuck

Similar to DIN 69882-8 with axial tool length adjustment
 HSK-A (hollow shank taper form A) shank according to DIN 69893-1

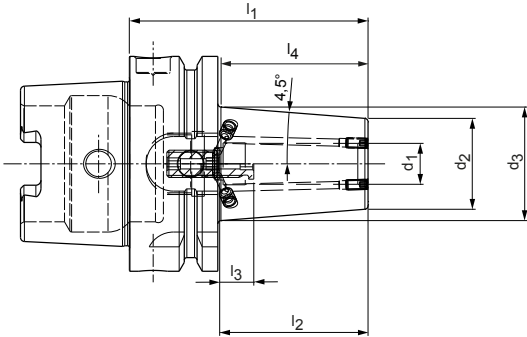

Design with two cooling channel bores, resealable

HSK-A	Dimensions							G	Specification	Order no.
	d ₁	d ₂	d ₃	l ₁	l ₂	l ₃	l ₄			
63	3,0	10,0	15,0	80,0	28,0	16,0	31,7	M6	MTC-HSK-A063-03-080-1-0-A	30654272
63*	3,0	10,0	20,0	120,0	12,0	-	63,5	-	MTC-HSK-A063-03-120-1-0-W	30654273
63	4,0	15,0	22,0	80,0	28,0	12,0	44,4	M6	MTC-HSK-A063-04-080-1-0-A	30654274
63*	4,0	15,0	22,0	120,0	16,0	-	44,4	-	MTC-HSK-A063-04-120-1-0-W	30654275
63	5,0	15,0	22,0	80,0	30,0	10,0	44,4	M6	MTC-HSK-A063-05-080-1-0-A	30654277
63*	5,0	15,0	22,0	120,0	20,0	-	44,4	-	MTC-HSK-A063-05-120-1-0-W	30654279
63	6,0	21,0	27,0	80,0	36,0	10,0	38,1	M5	MTC-HSK-A063-06-080-1-0-A	30654280
63	6,0	21,0	27,0	120,0	36,0	10,0	38,1	M5	MTC-HSK-A063-06-120-1-0-A	30654281
63	8,0	21,0	27,0	80,0	36,0	10,0	38,1	M6	MTC-HSK-A063-08-080-1-0-A	30654282
63	8,0	21,0	27,0	120,0	36,0	10,0	38,1	M6	MTC-HSK-A063-08-120-1-0-A	30654283
63	10,0	24,0	32,0	85,0	41,0	10,0	49,0	M8x1	MTC-HSK-A063-10-085-1-0-A	30654284
63	10,0	24,0	32,0	120,0	41,0	10,0	50,8	M8x1	MTC-HSK-A063-10-120-1-0-A	30654285
63	12,0	24,0	32,0	90,0	47,0	10,0	50,8	M10x1	MTC-HSK-A063-12-090-1-0-A	30654286
63	12,0	24,0	32,0	120,0	47,0	10,0	50,8	M10x1	MTC-HSK-A063-12-120-1-0-A	30654287
63	14,0	27,0	34,0	90,0	47,0	10,0	44,4	M10x1	MTC-HSK-A063-14-090-1-0-A	30654288
63	14,0	27,0	34,0	120,0	47,0	10,0	44,4	M10x1	MTC-HSK-A063-14-120-1-0-A	30654289
63	16,0	27,0	34,0	95,0	50,0	10,0	44,4	M12x1	MTC-HSK-A063-16-095-1-0-A	30654290
63	16,0	27,0	34,0	120,0	50,0	10,0	44,4	M12x1	MTC-HSK-A063-16-120-1-0-A	30654291
63	18,0	33,0	42,0	95,0	50,0	10,0	57,1	M12x1	MTC-HSK-A063-18-095-1-0-A	30654293
63	18,0	33,0	42,0	120,0	50,0	10,0	57,1	M12x1	MTC-HSK-A063-18-120-1-0-A	30654295
63	20,0	33,0	42,0	100,0	52,0	10,0	57,1	M16x1	MTC-HSK-A063-20-100-1-0-A	30654296
63	20,0	33,0	42,0	120,0	52,0	10,0	57,1	M16x1	MTC-HSK-A063-20-120-1-0-A	30654297
63	25,0	44,0	52,5	115,0	58,0	10,0	54,0	M16x1	MTC-HSK-A063-25-115-1-0-A	30654298
63	25,0	44,0	52,5	120,0	58,0	10,0	54,0	M16x1	MTC-HSK-A063-25-120-1-0-A	30654299
63	32,0	44,0	52,5	120,0	62,0	10,0	54,0	M16x1	MTC-HSK-A063-32-120-1-0-A	30654300

* Without axial tool length adjustment.

Dimensions in mm.

Additional dimensions available upon request.

Scope of delivery: With length adjustment screw with through hole fitted, screws for sealing the cooling channel bores. Without fine balancing screws and coolant tube.

Design: Permissible run-out variation of the hollow taper shank to the clamping diameter $d_1 = 3 \mu\text{m}$. The clamping diameter is designed for a shank tolerance of h6. Standard design with two cooling channel bores. Other cooling channel bores on request.

Note: Coolant tube and code carrier, see section "Accessories, spare parts and measuring equipment". Length adjustment screws and fine balancing screws available on request.

For notes on coding system, see section "Technical appendix".

Balancing quality: G 2.5 with 25,000 rpm in delivery status.

ThermoChuck

With axial tool length adjustment

SK shank according to ISO 7388-1 Form AD/AF

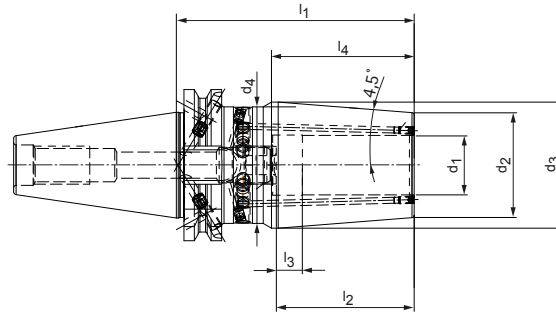
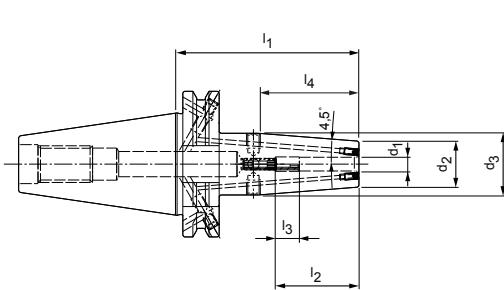

Design with two cooling channel bores, resealable

Steep taper	Dimensions								G	Specification	Order no.
	d ₁	d ₂	d ₃	d ₄	l ₁	l ₂	l ₃	l ₄			
40	3,0	10,0	17,0	-	80,0	28,0	16,0	44,4	M6	MTC-SK040-03-080-3-0-A	30655352
40*	3,0	10,0	20,0	-	120,0	12,0	-	63,5	-	MTC-SK040-03-120-3-0-W	30655355
40	4,0	15,0	22,0	-	80,0	28,0	12,0	44,4	M6	MTC-SK040-04-080-3-0-A	30655353
40*	4,0	15,0	22,0	-	120,0	16,0	-	44,4	-	MTC-SK040-04-120-3-0-W	30655356
40	5,0	15,0	22,0	-	80,0	30,0	10,0	44,4	M6	MTC-SK040-05-080-3-0-A	30655354
40*	5,0	15,0	22,0	-	120,0	20,0	-	44,4	-	MTC-SK040-05-120-3-0-W	30655357
40	6,0	21,0	27,0	-	80,0	36,0	10,0	38,1	M5	MTC-SK040-06-080-3-0-A	30655332
40	6,0	21,0	27,0	-	120,0	36,0	10,0	38,1	M5	MTC-SK040-06-120-3-0-A	30655342
40	8,0	21,0	27,0	-	80,0	36,0	10,0	38,1	M6	MTC-SK040-08-080-3-0-A	30655333
40	8,0	21,0	27,0	-	120,0	36,0	10,0	38,1	M6	MTC-SK040-08-120-3-0-A	30655343
40	10,0	24,0	32,0	-	80,0	41,0	10,0	50,8	M8x1	MTC-SK040-10-080-3-0-A	30655334
40	10,0	24,0	32,0	-	120,0	41,0	10,0	50,8	M8x1	MTC-SK040-10-120-3-0-A	30655344
40	12,0	24,0	32,0	-	80,0	47,0	10,0	50,8	M10x1	MTC-SK040-12-080-3-0-A	30655335
40	12,0	24,0	32,0	-	120,0	47,0	10,0	50,8	M10x1	MTC-SK040-12-120-3-0-A	30655345
40	14,0	27,0	34,0	-	80,0	47,0	10,0	44,4	M10x1	MTC-SK040-14-080-3-0-A	30655336
40	14,0	27,0	34,0	-	120,0	47,0	10,0	44,4	M10x1	MTC-SK040-14-120-3-0-A	30655346
40	16,0	27,0	34,0	-	80,0	50,0	10,0	44,4	M12x1	MTC-SK040-16-080-3-0-A	30655337
40	16,0	27,0	34,0	-	120,0	50,0	10,0	44,4	M12x1	MTC-SK040-16-120-3-0-A	30655347
40	18,0	33,0	42,0	-	80,0	50,0	10,0	57,1	M12x1	MTC-SK040-18-080-3-0-A	30655338
40	18,0	33,0	42,0	-	120,0	50,0	10,0	57,1	M12x1	MTC-SK040-18-120-3-0-A	30655348
40	20,0	33,0	42,0	-	80,0	52,0	10,0	57,1	M16x1	MTC-SK040-20-080-3-0-A	30655339
40	20,0	33,0	42,0	-	120,0	52,0	10,0	57,1	M16x1	MTC-SK040-20-120-3-0-A	30655349
40	25,0	44,0	53,0	49,0	100,0	58,0	10,0	57,1	M16x1	MTC-SK040-25-100-3-0-A	30655340
40	25,0	44,0	53,0	49,0	120,0	58,0	10,0	57,1	M16x1	MTC-SK040-25-120-3-0-A	30655350
40	32,0	44,0	53,0	49,0	100,0	62,0	10,0	57,1	M16x1	MTC-SK040-32-100-3-0-A	30655341
40	32,0	44,0	53,0	49,0	120,0	62,0	10,0	57,1	M16x1	MTC-SK040-32-120-3-0-A	30655351

* Without axial tool length adjustment.

Dimensions in mm.

Additional dimensions available upon request.

Scope of delivery: With built-in, drilled through length adjustment screw. Without fine balancing screws or pull studs.

Design: Permissible run-out variation on the taper shank in relation to the clamping diameter d₁ = 3 µm. The clamping diameter is designed for a shank tolerance of h6.

Standard design with two cooling channel bores. Other cooling channel bores on request.

Basic setting Form AD, if Form AF is required, please specify this when placing your order. Note: For pull stud, see section "Accessories, spare parts and measuring equipment".

Length adjustment screws and fine balancing screws available on request.

Balancing quality: G 2.5 with 25,000 rpm in delivery status.

Shrink chuck ThermoChuck

With axial tool length adjustment

Shank hollow shank taper E according to DIN 69893-5

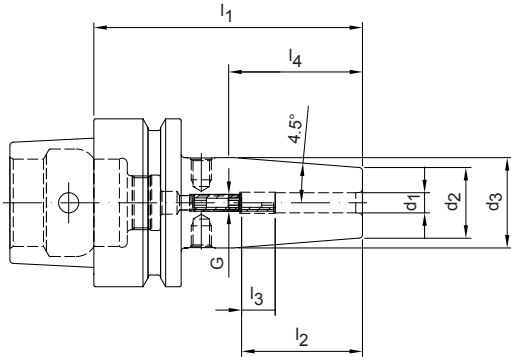

Available on request

HSK-E	Dimensions						Specification	Order no.
	d ₁	d ₂	d ₃	l ₁	l ₂	l ₄		
40	3,0	10,0	15,0	60,0	28,0	31,7	MTC-HSK-E040-03-060-1-0-A	30262004
40	4,0	10,0	15,0	60,0	28,0	31,7	MTC-HSK-E040-04-060-1-0-A	30262005
40	5,0	10,0	15,0	60,0	30,0	31,7	MTC-HSK-E040-05-060-1-0-A	30262006
40	6,0	21,0	27,0	80,0	36,0	38,1	MTC-HSK-E040-06-080-1-0-A	30262007
40	8,0	21,0	27,0	80,0	36,0	38,1	MTC-HSK-E040-08-080-1-0-A	30262008
40	10,0	24,0	32,0	80,0	41,0	50,8	MTC-HSK-E040-10-080-1-0-A	30262009
40	12,0	24,0	32,0	90,0	47,0	50,8	MTC-HSK-E040-12-090-1-0-A	30262010
50	3,0	10,0	15,0	80,0	28,0	31,7	MTC-HSK-E050-03-080-1-0-A	30262013
50	4,0	15,0	22,0	80,0	28,0	44,4	MTC-HSK-E050-04-080-1-0-A	30262015
50	5,0	15,0	22,0	80,0	30,0	44,4	MTC-HSK-E050-05-080-1-0-A	30262016
50	6,0	21,0	27,0	80,0	36,0	38,1	MTC-HSK-E050-06-080-1-0-A	30262017
50	8,0	21,0	27,0	80,0	36,0	38,1	MTC-HSK-E050-08-080-1-0-A	30262018
50	10,0	24,0	32,0	85,0	41,0	50,8	MTC-HSK-E050-10-085-1-0-A	30262019
50	12,0	24,0	32,0	90,0	47,0	50,8	MTC-HSK-E050-12-090-1-0-A	30262020

Dimensions in mm.

Additional dimensions available upon request.

Scope of delivery: without coolant tube.

Design: Permissible run-out variation of the hollow taper shank to the clamping diameter d₁ = 3 µm. The clamping diameter is designed for a shank tolerance of h6.

Note: Coolant tubes, see end of chapter.

Balancing quality for hollow shank taper 50: G 2.5 with 25,000 rpm in delivery status.





Mill Chuck, HB

Mill chuck for high-performance milling operations

The new mill chuck from MAPAL impresses with its strong clamping ability, easy handling and significantly improved radial run-out. The location bore is therefore manufactured with significantly more precision. This reduces the radial play of the clamped tool and considerably improves the radial run-out. The large tolerance on the lateral clamping surface is also compensated for.

To achieve this, MAPAL uses a spring element in the connection that enables a defined form fit between the tool and connection. Coolant channels parallel to the axis in the clamping range also ensure improved coolant supply.

A two-part clamping element is used to considerably simplify handling. This reduces the tightening torque while maintaining the same clamping force, allowing the tool to be clamped in the connection with manual force in a process-reliable manner.

AT A GLANCE

- Significantly fewer location bores
- Available with clamping diameters from 6 to 32 mm for hollow shank taper form A (HSK-A) and steep taper (SK)
- Balancing quality of G 2.5 at 16,000 rpm
- Can be easily combined with MAPAL high-performance milling cutters

ADVANTAGES

- Easy to handle thanks to a differential screw
- Maximum cost-effectiveness and precision
- Axial tool positioning can be defined using a spring system
- Decentralised coolant outlets for maximum process reliability

Tool features in detail

1 Decentralised coolant supply channels

- Optimum coolant supply

2 Differential screw

- Easy to handle

3 Spring package

- Perfect connection to the HB clamping surface

4 Contour

- Application-optimised contour for maximum rigidity

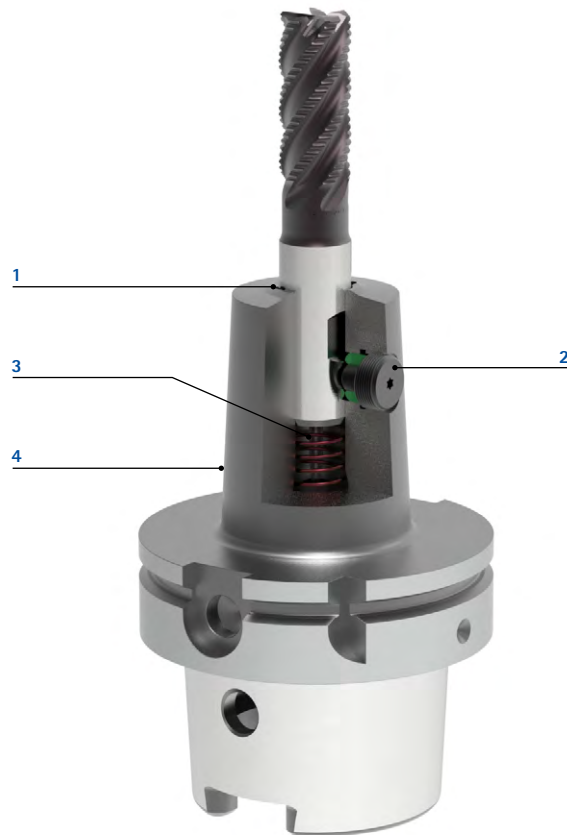

Optimal coolant supply

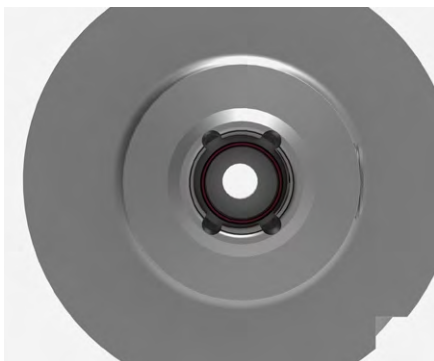

- Decentralised coolant supply channels
- Use of standard tools without internal cooling
- Tool life improved thanks to optimal cooling

Process-reliable tool clamping

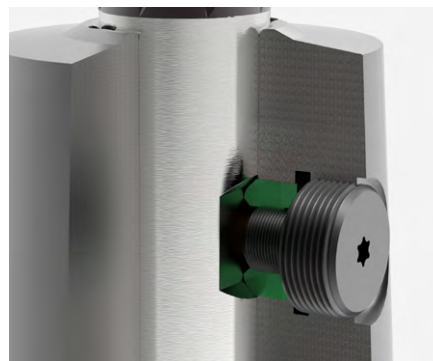

- High clamping force thanks to two-part clamping element
- Differential screw for reduced tightening torque
- Process-reliable clamping through self-locking

Defined milling cutter positioning

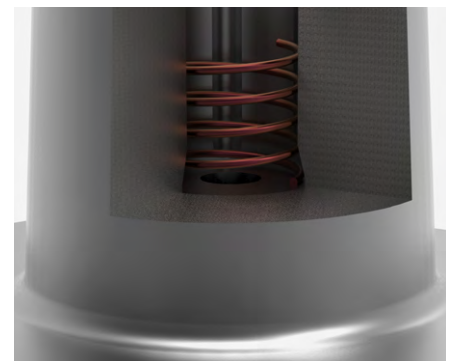

- Perfect connection to the HB clamping surface
- Form fit between tool and connection
- Prevents any pull-out during machining

Mill Chuck, HB

HSK-A (hollow shank taper form A) shank according to DIN 69893-1

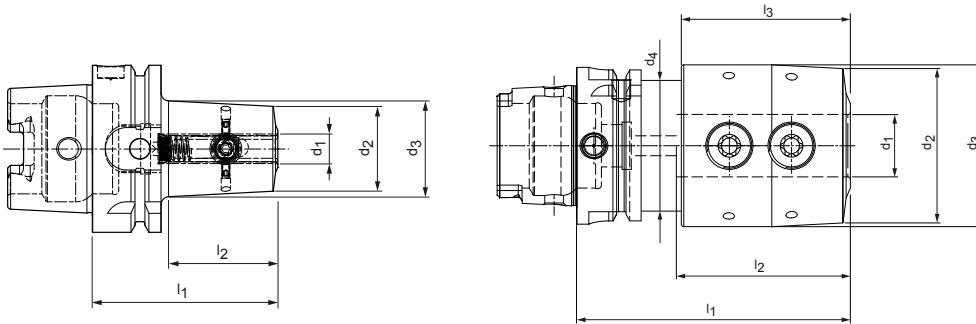

HSK-A	Dimensions							Specification	Order no.
	d ₁	d ₂	d ₃	d ₄	l ₁	l ₂	l ₃		
63	6,0	22,5	26,2	-	65,0	36,2	-	MWC-HSK-A063-06-065-1-0-W	30941344
63	8,0	25,0	28,7	-	65,0	36,2	-	MWC-HSK-A063-08-065-1-0-W	30941345
63	10,0	32,0	36,2	-	70,0	41,2	-	MWC-HSK-A063-10-070-1-0-W	30941346
63	12,0	37,5	42,7	-	80,0	51,2	-	MWC-HSK-A063-12-080-1-0-W	30941347
63	16,0	43,0	48,3	-	80,0	52,2	-	MWC-HSK-A063-16-080-1-0-W	30941349
63	20,0	46,5	52,0	-	80,0	54,0	-	MWC-HSK-A063-20-080-1-0-W	30941371
63	25,0	62,0	65,0	52,5	110,0	69,9	68,0	MWC-HSK-A063-25-110-1-0-W	30941372
63	32,0	69,0	72,0	52,5	110,0	69,9	68,0	MWC-HSK-A063-32-110-1-0-W	30941373
100	6,0	22,5	27,5	-	80,0	48,2	-	MWC-HSK-A100-06-080-1-0-W	30941374
100	8,0	25,0	30,0	-	80,0	48,2	-	MWC-HSK-A100-08-080-1-0-W	30941375
100	10,0	32,0	36,9	-	80,0	48,2	-	MWC-HSK-A100-10-080-1-0-W	30941376
100	12,0	37,5	42,9	-	85,0	53,2	-	MWC-HSK-A100-12-085-1-0-W	30941377
100	16,0	43,0	50,0	-	100,0	68,2	-	MWC-HSK-A100-16-100-1-0-W	30941379
100	20,0	46,5	53,5	-	100,0	68,2	-	MWC-HSK-A100-20-100-1-0-W	30941381
100	25,0	62,0	65,0	-	100,0	68,1	-	MWC-HSK-A100-25-100-1-0-W	30941382
100	32,0	69,0	72,0	-	110,0	78,1	-	MWC-HSK-A100-32-110-1-0-W	30925430

Dimensions in mm.

Additional dimensions available upon request.

Use: For connecting milling cutters with cylindrical shank and lateral drive area according to DIN 1835 Form B and DIN 6535 Form HB.

Scope of delivery: With built-in clamping screw, without coolant tube.

Design: Permissible run-out variation of the taper to the location bore $d_1 = 3 \mu\text{m}$.

The bore tolerance is much more restricted than DIN 1835 in order to achieve machining accuracies of the highest quality.

Note: There are two clamping screws from clamping diameter $d_1 = 25 \text{ mm}$.

Balancing quality: G 2.5 with 16,000 rpm in delivery status.

Mill Chuck, HB

SK shank according to ISO 7388-1 Form AD/AF

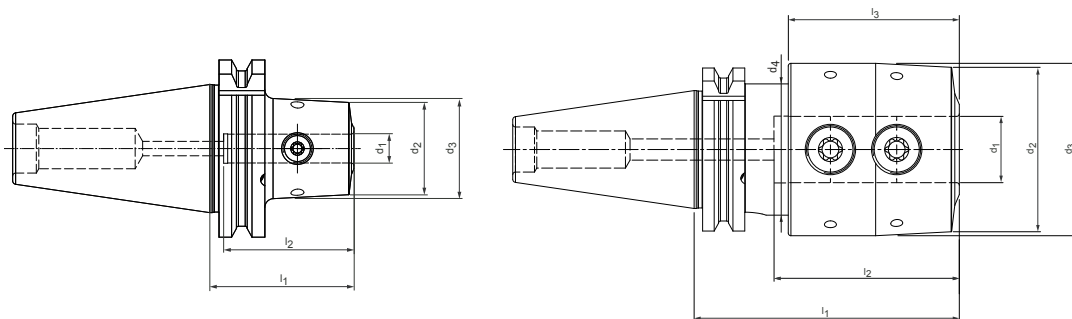

Steep taper	Dimensions							Specification	Order no.
	d ₁	d ₂	d ₃	d ₄	l ₁	l ₂	l ₃		
40	6,0	22,5	25,4	-	50,0	28,1	-	MWC-SK040-06-050-3-0-W	31059420
40	8,0	25,0	27,9	-	50,0	28,1	-	MWC-SK040-08-050-3-0-W	31059421
40	10,0	32,0	34,8	-	50,0	28,1	-	MWC-SK040-10-050-3-0-W	31059422
40	12,0	37,5	40,3	-	50,0	28,1	-	MWC-SK040-12-050-3-0-W	31059423
40	16,0	43,0	47,3	-	63,0	43,0	-	MWC-SK040-16-063-3-0-W	31059425
40	20,0	46,5	49,5	-	63,0	43,0	-	MWC-SK040-20-063-3-0-W	31059427
40	25,0	62,0	65,0	49,5	100,0	69,9	64,5	MWC-SK040-25-100-3-0-W	31059428
40	32,0	69,0	72,0	49,5	100,0	69,9	64,5	MWC-SK040-32-100-3-0-W	31059429
50	6,0	22,5	26,7	-	63,0	41,1	-	MWC-SK050-06-063-3-0-W	31059430
50	8,0	25,0	29,2	-	63,0	41,1	-	MWC-SK050-08-063-3-0-W	31059431
50	10,0	32,0	36,2	-	63,0	41,1	-	MWC-SK050-10-063-3-0-W	31059432
50	12,0	37,5	41,7	-	63,0	41,1	-	MWC-SK050-12-063-3-0-W	31059433
50	16,0	43,0	47,1	-	63,0	41,1	-	MWC-SK050-16-063-3-0-W	31059435
50	20,0	46,5	50,6	-	63,0	41,1	-	MWC-SK050-20-063-3-0-W	31059437
50	25,0	62,0	67,8	-	80,0	58,1	-	MWC-SK050-25-080-3-0-W	31059438
50	32,0	69,0	76,9	-	100,0	78,1	-	MWC-SK050-32-100-3-0-W	31059439

Dimensions in mm.

Additional dimensions available upon request.

Use: For connecting milling cutters with cylindrical shank and lateral drive area according to DIN 1835 Form B and DIN 6535 Form HB.

Scope of delivery: Built-in clamping screw, does not include pull stud.

Design: Permissible run-out variation of the taper to the location bore $d_1 = 3 \mu\text{m}$. The bore

tolerance is much more restricted than DIN 1835 in order to achieve machining accuracies of the highest quality.

Note: There are two clamping screws from clamping diameter $d_1 = 25 \text{ mm}$.

Balancing quality: G 2.5 with 16,000 rpm in delivery status.

Precision-DrillChuck

With radial actuation and internal coolant supply

HSK-A (hollow shank taper form A) shank according to DIN 69893-1

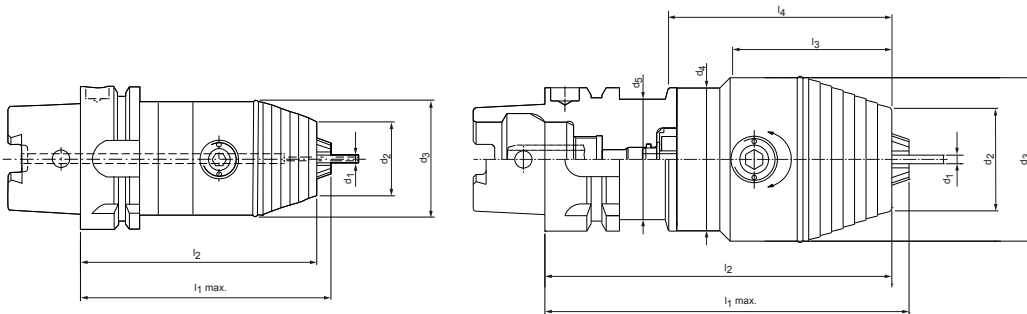

HSK-A	Dimensions										Specification	Order no.
	Clamping range d_1	d_2	d_3	d_4	d_5	l_1	l_2	l_3	l_4			
32	0,3 - 8,0	23,0	36,0	25,4	-	93,0	90,0	53,0	-	MPC-HSK-A032-08-093-1-0-W	30259870	
40	0,3 - 8,0	23,0	36,0	33,5	-	94,0	91,0	55,0	-	MPC-HSK-A040-08-094-1-0-W	30259871	
50	0,3 - 8,0	23,0	36,0	-	-	98,0	95,0	-	-	MPC-HSK-A050-08-098-1-0-W	30259872	
50	0,5 - 13,0	35,0	50,0	41,5	-	122,0	116,0	73,0	-	MPC-HSK-A050-13-122-1-0-W	30259874	
50	2,5 - 16,0	36,0	57,0	50,0	41,5	127,0	121,0	56,5	78,0	MPC-HSK-A050-16-127-1-0-W	30259878	
63	0,3 - 8,0	23,0	36,0	-	-	99,0	96,0	-	-	MPC-HSK-A063-08-099-1-0-W	30259873	
63	0,5 - 13,0	35,0	50,0	-	-	110,0	104,0	-	-	MPC-HSK-A063-13-110-1-0-W	30259875	
63	2,5 - 16,0	36,0	57,0	49,8	-	115,0	109,0	56,5	-	MPC-HSK-A063-16-115-1-0-W	30259879	
100	0,5 - 13,0	35,0	50,0	-	-	117,0	111,0	-	-	MPC-HSK-A100-13-117-1-0-W	30259877	
100	2,5 - 16,0	36,0	57,0	49,8	-	122,0	116,0	56,5	-	MPC-HSK-A100-16-122-1-0-W	30259881	

Dimensions in mm.

Additional dimensions available upon request.

Use: For clamping tools with smooth cylindrical shanks.

Scope of delivery: Including hexagonal wrench with T-handle.

Without sealing disc and coolant tube.

Design: With internal coolant supply.

Note: Spare parts and accessories can be found via the spare part code in section "Accessories, spare parts and measuring equipment".

Balancing quality: G 6.3 with 25,000 rpm in delivery status.

Micro-Precision-DrillChuck

With radial actuation and internal coolant supply
 HSK-A (hollow shank taper form A) shank according to DIN 69893-1

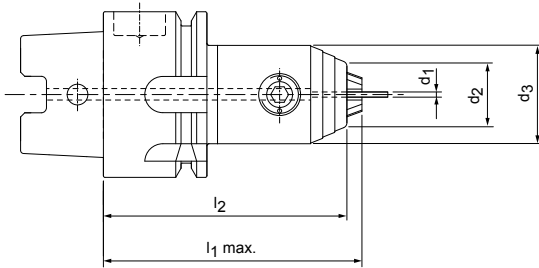

HSK-A	Dimensions					Specification	Order no.
	Clamping range d_1	d_2	d_3	l_1	l_2		
32	0,2 - 3,4	12,5	19,0	49,0	46,0	MPC-HSK-A032-03-049-1-0-W	30551128
32	0,2 - 6,4	16,0	25,0	58,0	54,0	MPC-HSK-A032-06-058-1-0-W	30608019
40	0,2 - 3,4	12,5	19,0	49,0	46,0	MPC-HSK-A040-03-049-1-0-W	30551129
40	0,2 - 6,4	16,0	25,0	58,0	54,0	MPC-HSK-A040-06-058-1-0-W	30608021
50	0,2 - 3,4	12,5	19,0	55,0	52,0	MPC-HSK-A050-03-055-1-0-W	30551130
50	0,2 - 6,4	16,0	25,0	65,0	61,0	MPC-HSK-A050-06-065-1-0-W	30608022

Dimensions in mm.

Additional dimensions available upon request.

Use: For clamping tools with smooth cylindrical shanks.

Scope of delivery: Including hexagonal wrench with T-handle.

Without sealing disc and coolant tube.

Design: With internal coolant supply.

Note: Spare parts and accessories can be found via the spare part code in section "Accessories, spare parts and measuring equipment".

Balancing quality: G 6.3 with 25,000 rpm in delivery status.

Precision-DrillChuck

With radial actuation and internal coolant supply
SK shank according to ISO 7388-1 Form AD/AF

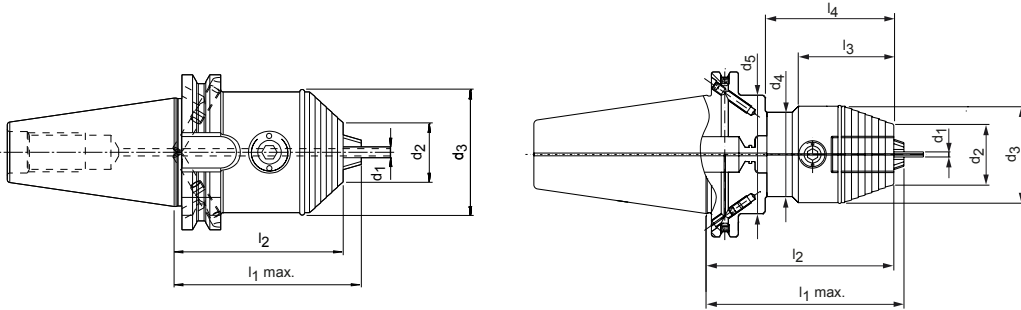

Steep taper	Dimensions									Specification	Order no.
	Clamping range d ₁	d ₂	d ₃	d ₄	d ₅	l ₁	l ₂	l ₃	l ₄		
40	0,3 - 8,0	23,0	36,0	-	-	76,0	73,0	-	-	MPC-SK040-08-076-3-0-W	30259844
40	0,5 - 13,0	35,0	50,0	-	-	96,0	90,0	-	-	MPC-SK040-13-096-3-0-W	30259845
40	2,5 - 16,0	36,0	57,0	49,8	-	101,0	95,0	56,5	-	MPC-SK040-16-101-3-0-W	30259848
50	0,5 - 13,0	35,0	50,0	70,0	-	112,0	105,0	73,0	-	MPC-SK050-13-112-3-0-W	30259847
50	2,5 - 16,0	36,0	57,0	49,8	70,0	117,0	111,0	56,5	77,1	MPC-SK050-16-117-3-0-W	30259850

Dimensions in mm.
Additional dimensions available upon request.

Use: For clamping tools with smooth cylindrical shanks.
Scope of delivery: Including hexagonal wrench with T-handle.
Without sealing disc and pull stud.
Design: With internal coolant supply. Basic setting Form AD, if Form AF is required, please specify this when placing your order.

Note: Spare parts and accessories can be found via the spare part code in section "Accessories, spare parts and measuring equipment".
Balancing quality: G 6.3 with 25,000 rpm in delivery status.

Micro-Precision-DrillChuck

With radial actuation and internal coolant supply

Shank BT according to ISO 7388-2 Form JD (JIS B 6339)

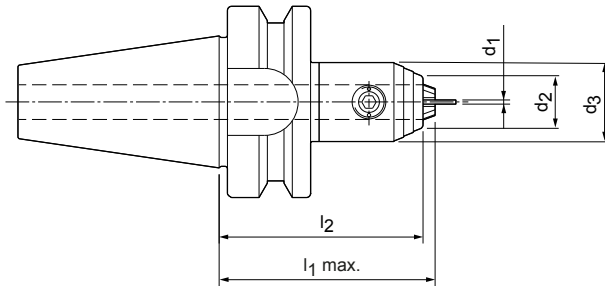

BT	Dimensions					Specification	Order no.
	Clamping range d_1	d_2	d_3	l_1	l_2		
30	0,2 - 3,4	12,5	19,0	51,0	48,0	MPC-BT030-03-051-1-0-W	30551229
30	0,2 - 6,4	16,0	25,0	62,0	58,0	MPC-BT030-06-062-1-0-W	30608027

Dimensions in mm.

Additional dimensions available upon request.

Use: For clamping tools with smooth cylindrical shanks.

Scope of delivery: Including hexagonal wrench with T-handle.

Without sealing disc and pull stud.

Note: Spare parts and accessories can be found via the spare part code in section "Accessories, spare parts and measuring equipment".

Balancing quality: G 6.3 with 25,000 rpm in delivery status.



↑↑↑
WITHOUT vibration damper

↑↑↑
WITH vibration damper

VIBRATION DAMPENING

Significantly better surfaces

Vibrations often occur during machining. They cause the system to become dynamically unstable. This can result in unacceptable surface quality, insufficient accuracy, high levels of machining noise, shortened tool life, and broken tools and cutting edges in extreme cases.

To minimise these vibrations and their consequences, MAPAL has developed an innovative system for vibration dampening in the tool shank. In particular, tools for boring and milling with very long projections tend to vibrate due to the insufficient dynamic rigidity of the overall system. When designing the new system, the developers took into account all the factors resulting from the interaction between the machine tool, the tool and its clamp, and the part. The result: a vibration dampening system that is calibrated to the rigidity of all common machine types. It can be used for the machining of a range of workpiece materials with various different tools.

The self-contained system made of auxiliary mass and several steel spring packages counteracts and minimises the displacement of the tool body. Compared to tools without an absorber system, the vibration amplitudes can be up to 1,000 times lower. As such, a smooth, stable run is achieved even with long projections. This allows higher cutting speeds to be used and the material removal rate to be significantly increased. In addition, considerably better surface finishes are achieved thanks to the vibration dampening.

AT A GLANCE

- System for vibration dampening in tools with long projections directly in the tool shank
- Adapted to the rigidity of all common machine types
- Available with internal coolant supply for the clamping diameters 16, 22 and 27 mm with a length of 200 and 300 mm for the SK40, SK50, HSK-A63 and HSK-A100 connections

ADVANTAGES

- Smooth, stable running despite long projections
- Higher cutting speeds, higher material removal rate
- Better surface qualities

Tool features in detail

1 Internal coolant supply channels

- Optimum coolant supply

2 Standardised connection according to DIN 69882-3

- Suitable for standard milling cutters with cross slot

3 Hard turned surface

- Improved corrosion resistance

4 Cylindrical contour

- Optimum accessibility



Vibration dampening in the milling cutter arbor



- Smooth, stable running despite long projections
- Protection of spindle and machine with lower energy consumption than with an undamped system
- Noise is minimised in the machining process

Internal coolant supply



- Internal cooling enables higher cutting speeds with better material removal rates
- Less blade chipping
- Optimal cooling of the cutting edge enables deep machining positions

Better surface qualities thanks to vibration dampening

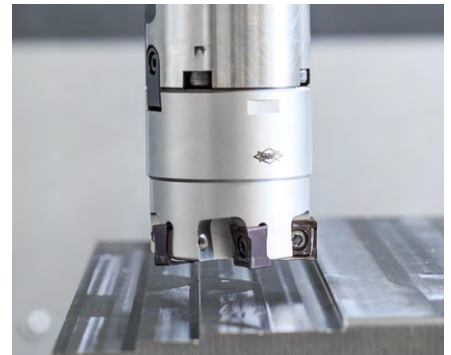

- Significantly improved surface with identical cutting data compared to undamped systems
- Optimum chip breaking, surfaces are not scratched

Milling cutter arbor

Mechanical tool clamping, for milling cutters with cross slot according to DIN 69882-3
 HSK-A (hollow shank taper form A) shank according to DIN 69893-1

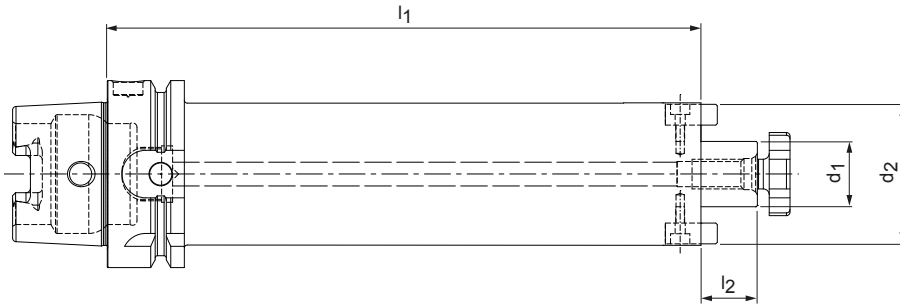

Vibration dampened design

HSK-A	Dimensions				Specification	Order no.
	d_1	d_2	l_1	l_2		
63	16,0	38,0	200,0	17,0	MDA-HSK-A063-16-200-1-0-W	31045047
63	16,0	38,0	300,0	17,0	MDA-HSK-A063-16-300-1-0-W	31045049
63	22,0	48,0	200,0	19,0	MDA-HSK-A063-22-200-1-0-W	31045048
63	22,0	48,0	300,0	19,0	MDA-HSK-A063-22-300-1-0-W	31045120
100	16,0	38,0	200,0	17,0	MDA-HSK-A100-16-200-1-0-W	31045121
100	16,0	38,0	300,0	17,0	MDA-HSK-A100-16-300-1-0-W	31045124
100	22,0	48,0	200,0	19,0	MDA-HSK-A100-22-200-1-0-W	31045122
100	22,0	48,0	300,0	19,0	MDA-HSK-A100-22-300-1-0-W	31045125
100	27,0	58,0	200,0	21,0	MDA-HSK-A100-27-200-1-0-W	31045123
100	27,0	58,0	300,0	21,0	MDA-HSK-A100-27-300-1-0-W	31045126

Technical data of the milling cutter arbor with hollow shank taper connection

Order no.	Max. operating speed [rpm]	Recommended weight for milling cutter [kg]	Total mass [kg]	Moment of tilt with milling cutter nominal weight [Nm]	Permissible transferable torque [Nm]	Max. cutting force [N]
31045047	8.000	0,2 ($\pm 0,1$)	2,3	1,89	200	1.300
31045049	5.000	0,2 ($\pm 0,1$)	3,2	4,22	200	900
31045048	8.000	0,6 ($\pm 0,15$)	3,5	4,08	270	1.300
31045120	5.500	0,6 ($\pm 0,15$)	4,9	8,32	270	900
31045121	8.000	0,2 ($\pm 0,1$)	3,6	1,57	200	3.400
31045124	5.800	0,2 ($\pm 0,1$)	4,5	3,95	200	2.400
31045122	8.000	0,6 ($\pm 0,15$)	4,7	3,65	270	3.400
31045125	6.000	0,6 ($\pm 0,15$)	6	7,61	270	2.400
31045123	8.000	0,9 ($\pm 0,2$)	5,8	5,23	500	3.400
31045126	6.000	0,9 ($\pm 0,2$)	8	11,37	500	2.400

Dimensions in mm.

Scope of delivery: With screwed-on key blocks and milling cutter clamping screw according to DIN 6367. Without coolant tube.

Design: Permissible run-out variation of the taper to the arbor diameter $d_1 = 5 \mu\text{m}$.

Note: Milling cutter clamping screw supplied without internal cooling. Coolant tubes and assembly tool, see section "Accessories, spare parts and measuring equipment".

Milling cutter arbor

Mechanical tool clamping, for milling cutters with cross slot according to DIN 69882-3
SK (steel taper) shank according to ISO 7388-1 Form AD/AF

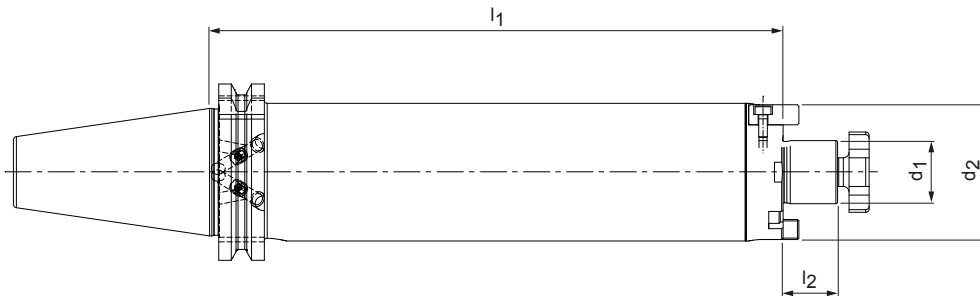

Vibration dampened design

Steep taper	Dimensions				Specification	Order no.
	d ₁	d ₂	l ₁	l ₂		
40	16,0	38,0	200,0	17,0	MDA-SK040-16-200-3-0-W	31045127
40	16,0	38,0	300,0	17,0	MDA-SK040-16-300-3-0-W	31045129
40	22,0	48,0	200,0	19,0	MDA-SK040-22-200-3-0-W	31045128
40	22,0	48,0	300,0	19,0	MDA-SK040-22-300-3-0-W	31045130
50	16,0	38,0	200,0	17,0	MDA-SK050-16-200-3-0-W	31045131
50	16,0	38,0	300,0	17,0	MDA-SK050-16-300-3-0-W	31045134
50	22,0	48,0	200,0	19,0	MDA-SK050-22-200-3-0-W	31045132
50	22,0	48,0	300,0	19,0	MDA-SK050-22-300-3-0-W	31045135
50	27,0	58,0	200,0	21,0	MDA-SK050-27-200-3-0-W	31045133
50	27,0	58,0	300,0	21,0	MDA-SK050-27-300-3-0-W	31045136

Technical data of the milling cutter arbor with steep taper connection

Order no.	Max. operating speed [rpm]	Recommended weight for milling cutter [kg]	Total mass [kg]	Moment of tilt with milling cutter nominal weight [Nm]	Permissible transferable torque [Nm]	Max. cutting force [N]
31045127	8.000	0,2 (±0,1)	2,5	1,90	200	650
31045129	4.500	0,2 (±0,1)	3,4	4,32	200	450
31045128	5.500	0,6 (±0,15)	3,7	4,19	270	650
31045130	3.500	0,6 (±0,15)	5,1	8,85	270	450
31045131	8.000	0,2 (±0,1)	4,2	1,22	200	1.700
31045134	6.000	0,2 (±0,1)	5,1	3,67	200	1.200
31045132	8.000	0,6 (±0,15)	5,3	3,34	270	1.700
31045135	5.500	0,6 (±0,15)	6,9	7,87	270	1.200
31045133	8.000	0,9 (±0,2)	6,6	5,13	500	1.700
31045136	5.000	0,9 (±0,2)	8,8	11,59	500	1.200

Dimensions in mm.

Scope of delivery: With screwed-on key blocks and milling cutter clamping screw according to DIN 6367. Without pull stud.

Design: Permissible run-out variation of the taper to the arbor diameter d₁ = 5 µm.
Basic setting Form AD, if Form AF is required, please specify this when placing your order.

Note: Milling cutter clamping screw supplied without internal cooling. For pull stud and assembly tool, see section "Accessories, spare parts and measuring equipment".

Milling cutter arbor

Mechanical tool clamping

With enlarged face connection diameter according to DIN 69882-3

HSK-A (hollow shank taper form A) shank according to DIN 69893-1

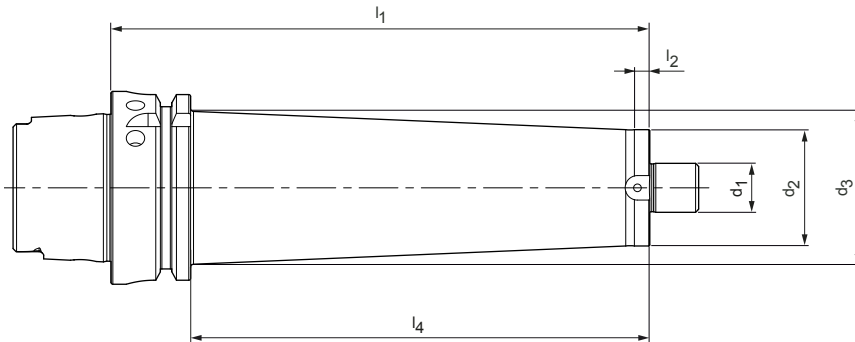

Preferred series in stock

HSK-A	Dimensions						Specification	Order no.
	d ₁	d ₂	d ₃	l ₁	l ₂	l ₄		
63	16,0	38,0	42,0	76,0	8,0	50,0	MCA-HSK-A063-16-076-1-0-W	31184154
63	16,0	38,0	50,0	126,0	8,0	100,0	MCA-HSK-A063-16-126-1-0-W	31184089
63	16,0	38,0	50,0	176,0	8,0	150,0	MCA-HSK-A063-16-176-1-0-W	31184104
63	22,0	48,0	48,0	76,0	-	50,0	MCA-HSK-A063-22-076-1-0-W	31184157
63	22,0	48,0	50,0	126,0	8,0	100,0	MCA-HSK-A063-22-126-1-0-W	31184094
63	22,0	48,0	49,0	176,0	8,0	150,0	MCA-HSK-A063-22-176-1-0-W	31184106
100	22,0	48,0	50,0	129,0	8,0	100,0	MCA-HSK-A100-22-129-1-0-W	31184093
100	22,0	48,0	50,0	229,0	8,0	200,0	MCA-HSK-A100-22-229-1-0-W	31184110
100	27,0	62,0	71,0	129,0	8,0	100,0	MCA-HSK-A100-27-129-1-0-W	31184096
100	27,0	62,0	80,0	229,0	8,0	200,0	MCA-HSK-A100-27-229-1-0-W	31184112

Available on request

63	16,0	38,0	40,0	51,0	8,0	25,0	MCA-HSK-A063-16-051-1-0-W	31227511
63	16,0	38,0	45,0	101,0	8,0	75,0	MCA-HSK-A063-16-101-1-0-W	31227515
63	16,0	38,0	50,0	151,0	8,0	125,0	MCA-HSK-A063-16-151-1-0-W	31227506
63	16,0	38,0	50,0	226,0	8,0	200,0	MCA-HSK-A063-16-226-1-0-W	31227508
63	22,0	48,0	48,0	51,0	-	25,0	MCA-HSK-A063-22-051-1-0-W	31227512
63	22,0	48,0	50,0	101,0	8,0	75,0	MCA-HSK-A063-22-101-1-0-W	31227516
63	22,0	48,0	49,0	226,0	8,0	200,0	MCA-HSK-A063-22-226-1-0-W	31227509
63	27,0	48,0	48,0	51,0	-	25,0	MCA-HSK-A063-27-051-1-0-W	31227513
63	27,0	48,0	48,0	76,0	-	50,0	MCA-HSK-A063-27-076-1-0-W	31227514
63	27,0	48,0	48,0	101,0	-	75,0	MCA-HSK-A063-27-101-1-0-W	31227517
63	27,0	48,0	48,0	126,0	-	100,0	MCA-HSK-A063-27-126-1-0-W	31227505
63	27,0	48,0	48,0	176,0	-	150,0	MCA-HSK-A063-27-176-1-0-W	31227507
63	27,0	48,0	50,0	226,0	8,0	200,0	MCA-HSK-A063-27-226-1-0-W	31227510
100	22,0	48,0	48,0	79,0	-	50,0	MCA-HSK-A100-22-079-1-0-W	31227522
100	22,0	48,0	48,0	104,0	-	75,0	MCA-HSK-A100-22-104-1-0-W	31227526
100	22,0	48,0	50,0	179,0	8,0	150,0	MCA-HSK-A100-22-179-1-0-W	31227519
100	27,0	62,0	62,0	79,0	-	50,0	MCA-HSK-A100-27-079-1-0-W	31227523
100	27,0	62,0	62,0	104,0	-	75,0	MCA-HSK-A100-27-104-1-0-W	31227527
100	27,0	62,0	80,0	179,0	8,0	150,0	MCA-HSK-A100-27-179-1-0-W	31227520
100	32,0	85,0	85,0	79,0	-	50,0	MCA-HSK-A100-32-079-1-0-W	31227524
100	32,0	85,0	85,0	129,0	-	100,0	MCA-HSK-A100-32-129-1-0-W	31227518
100	32,0	85,0	85,0	179,0	-	150,0	MCA-HSK-A100-32-179-1-0-W	31227521
100	40,0	100,0	88,0	79,0	-	50,0	MCA-HSK-A100-40-079-1-0-W	31227525

Dimensions in mm.

Additional dimensions available upon request.

Scope of delivery: With screwed-on key blocks. Without coolant tube.

Design: Permissible run-out variation of the hollow taper shank to the arbor $d_1 = 8 \mu\text{m}$.

Note: Fastening screws according to ISO 4762 and milling cutter clamping screws according to DIN 6367, see "Clamping" catalogue.

For coolant tubes, see end of chapter. Milling adapter rings according to DIN 2084 available upon request.

Balancing quality: G 6.3 with 25,000 rpm in delivery status.

Milling cutter arbor

Mechanical tool clamping

With enlarged face connection diameter

SK shank according to ISO 7388-1 Form AD/AF

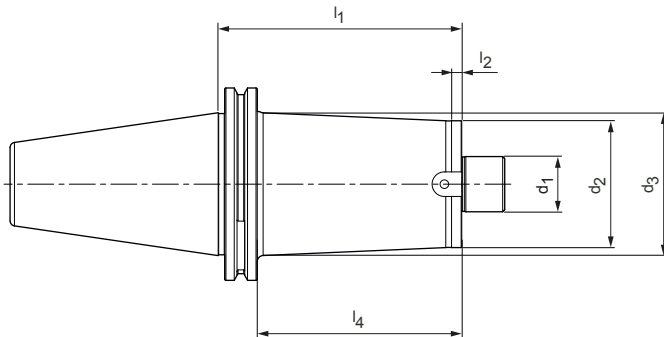

Preferred series in stock

Steep taper	Dimensions						Specification	Order no.
	d ₁	d ₂	d ₃	l ₁	l ₂	l ₄		
40	16,0	38,0	42,0	69,1	8,0	50,0	MCA-SK040-16-069-1-0-W	31184149
40	16,0	38,0	48,0	119,1	8,0	100,0	MCA-SK040-16-119-1-0-W	31184083
40	16,0	38,0	50,0	169,1	8,0	150,0	MCA-SK040-16-169-1-0-W	31184102
40	22,0	48,0	48,0	69,1	-	50,0	MCA-SK040-22-069-1-0-W	31184156
40	22,0	48,0	48,0	119,1	-	100,0	MCA-SK040-22-119-1-0-W	31184092
40	22,0	48,0	48,0	169,1	-	150,0	MCA-SK040-22-169-1-0-W	31184105
50	22,0	48,0	50,0	119,1	8,0	100,0	MCA-SK050-22-119-1-0-W	31184091
50	22,0	48,0	78,0	219,1	8,0	200,0	MCA-SK050-22-219-1-0-W	31184109
50	27,0	62,0	70,0	119,1	8,0	100,0	MCA-SK050-27-119-1-0-W	31184095
50	27,0	62,0	76,0	219,1	8,0	200,0	MCA-SK050-27-219-1-0-W	31184111
50	32,0	95,0	78,0	69,1	8,0	50,0	MCA-SK050-32-069-1-0-W	31215772
50	40,0	100,0	78,0	69,1	-	50,0	MCA-SK050-40-069-1-0-W	31215773
50	60,0	129,0	78,0	69,1	-	50,0	MCA-SK050-60-069-1-0-W	31215775

Available on request

40	16,0	38,0	40,0	44,1	8,0	25,0	MCA-SK040-16-044-1-0-W	31227483
40	16,0	38,0	45,0	94,1	8,0	75,0	MCA-SK040-16-094-1-0-W	31227486
40	16,0	38,0	50,0	144,1	8,0	125,0	MCA-SK040-16-144-1-0-W	31227479
40	16,0	38,0	50,0	219,1	8,0	200,0	MCA-SK040-16-219-1-0-W	31227481
40	22,0	48,0	48,0	44,1	-	25,0	MCA-SK040-22-044-1-0-W	31227484
40	22,0	48,0	48,0	94,1	-	75,0	MCA-SK040-22-094-1-0-W	31227487
40	22,0	48,0	48,0	219,1	-	200,0	MCA-SK040-22-219-1-0-W	31227482
40	27,0	48,0	48,0	34,1	-	15,0	MCA-SK040-27-034-1-0-W	31227480
40	27,0	48,0	48,0	69,1	-	50,0	MCA-SK040-27-069-1-0-W	31227485
40	27,0	48,0	48,0	94,1	-	75,0	MCA-SK040-27-094-1-0-W	31227488
40	27,0	48,0	48,0	119,1	-	100,0	MCA-SK040-27-119-1-0-W	31227478
50	16,0	38,0	42,0	69,1	8,0	50,0	MCA-SK050-16-069-1-0-W	31227458
50	16,0	38,0	50,0	119,1	8,0	100,0	MCA-SK050-16-119-1-0-W	31227446
50	16,0	38,0	50,0	169,1	8,0	150,0	MCA-SK050-16-169-1-0-W	31227449
50	16,0	38,0	50,0	219,1	8,0	200,0	MCA-SK050-16-219-1-0-W	31227453
50	16,0	38,0	50,0	269,1	8,0	250,0	MCA-SK050-16-269-1-0-W	31227455
50	22,0	48,0	48,0	69,1	8,0	50,0	MCA-SK050-22-069-1-0-W	31227459
50	22,0	48,0	62,0	169,1	8,0	150,0	MCA-SK050-22-169-1-0-W	31227450
50	22,0	48,0	78,0	269,1	8,0	250,0	MCA-SK050-22-269-1-0-W	31227456
50	27,0	62,0	62,0	69,1	-	50,0	MCA-SK050-27-069-1-0-W	31227460
50	27,0	62,0	76,0	169,1	8,0	150,0	MCA-SK050-27-169-1-0-W	31227451
50	27,0	62,0	76,0	269,1	8,0	250,0	MCA-SK050-27-269-1-0-W	31227457
50	32,0	95,0	78,0	119,1	8,0	100,0	MCA-SK050-32-119-1-0-W	31227447

Continued on next page.

Milling cutter arbor | Mechanical tool clamping | With increased face connection diameter | SK shank in accordance ISO 7388-1 Form AD/AF

Steep taper	Dimensions						Specification	Order no.
	d ₁	d ₂	d ₃	l ₁	l ₂	l ₄		
50	32,0	95,0	78,0	169,1	8,0	150,0	MCA-SK050-32-169-1-0-W	31227452
50	32,0	95,0	78,0	219,1	8,0	200,0	MCA-SK050-32-219-1-0-W	31227454
50	40,0	100,0	78,0	119,1	-	100,0	MCA-SK050-40-119-1-0-W	31227448

Dimensions in mm.

Additional dimensions available upon request.

Scope of delivery: With screwed-on key blocks. Without fastening screws and milling cutter clamping screw. Without pull stud.

Design: Permissible run-out variation of the taper to the arbor diameter d₁ = 8 µm.

Note: Fastening screws according to ISO 4762 and milling cutter clamping screws according to DIN 6367, see "Clamping" catalogue. Coolant tubes, see end of chapter.

Milling adapter rings according to DIN 2084 available upon request

Balancing quality: G 16 with 8,000 rpm in delivery status.

Milling cutter arbor

Mechanical tool clamping

With enlarged face connection diameter

Shank BT according to ISO 7388-2 Form JD/JF (JIS B 6339)

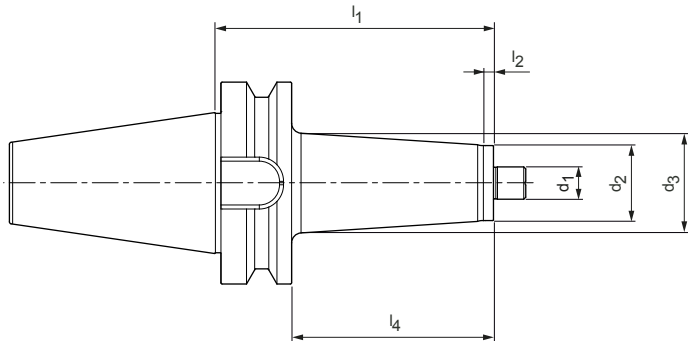

Available on request

BT	Dimensions						Specification	Order no.
	d_1	d_2	d_3	l_1	l_2	l_4		
40	16,0	38,0	42,0	77,0	8,0	50,0	MCA-BT040-16-077-1-0-W	31227499
40	16,0	38,0	48,0	127,0	8,0	100,0	MCA-BT040-16-127-1-0-W	31227489
40	22,0	48,0	48,0	127,0	8,0	100,0	MCA-BT040-22-127-1-0-W	31227490
40	27,0	48,0	48,0	77,0	-	50,0	MCA-BT040-27-077-1-0-W	31227501
40	27,0	48,0	48,0	127,0	-	100,0	MCA-BT040-27-127-1-0-W	31227491
50	16,0	38,0	42,0	88,0	8,0	50,0	MCA-BT050-16-088-1-0-W	31227472
50	16,0	38,0	50,0	138,0	8,0	100,0	MCA-BT050-16-138-1-0-W	31227461
50	22,0	48,0	48,0	88,0	8,0	50,0	MCA-BT050-22-088-1-0-W	31227473
50	22,0	48,0	50,0	138,0	8,0	100,0	MCA-BT050-22-138-1-0-W	31227462
50	27,0	62,0	62,0	88,0	8,0	50,0	MCA-BT050-27-088-1-0-W	31227474
50	27,0	62,0	70,0	138,0	8,0	100,0	MCA-BT050-27-138-1-0-W	31227463
50	32,0	95,0	78,0	88,0	8,0	50,0	MCA-BT050-32-088-1-0-W	31227475
50	32,0	95,0	78,0	138,0	8,0	100,0	MCA-BT050-32-138-1-0-W	31227464
50	40,0	100,0	78,0	88,0	-	50,0	MCA-BT050-40-088-1-0-W	31227476
50	60,0	129,0	78,0	88,0	-	50,0	MCA-BT050-60-088-1-0-W	31227477

Dimensions in mm.

Scope of delivery: With screwed-on key blocks and milling cutter clamping screw according to DIN 6367. Without pull stud.

Design: Permissible run-out variation on the taper in relation to the arbor diameter $d_1 \leq 8 \mu\text{m}$

Note: For pull studs and assembly tools, see section "Accessories, spare parts and measuring equipment".

Balancing quality: G 2.5 with 16,000 rpm in delivery status.

MFS milling head holder

Mechanical tool clamping

For screw-in milling cutter, made from steel

HSK-A (hollow shank taper form A) shank according to DIN 69893-1

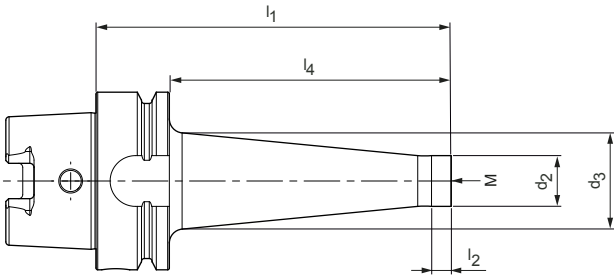

Preferred series in stock

HSK-A	Dimensions						Specification	Order no.
	M	d ₂	d ₃	l ₁	l ₂	l ₄		
63	8,0	14,0	23,0	76,0	12,0	50,0	MFS201N-M08-076-HSK-A063-S	31184124
63	8,0	14,0	30,0	126,0	12,0	100,0	MFS201N-M08-126-HSK-A063-S	31184059
63	10,0	18,0	25,0	76,0	12,0	50,0	MFS201N-M10-076-HSK-A063-S	31184130
63	10,0	18,0	35,0	126,0	12,0	100,0	MFS201N-M10-126-HSK-A063-S	31184066
63	12,0	21,0	30,0	76,0	12,0	50,0	MFS201N-M12-076-HSK-A063-S	31184140
63	12,0	21,0	43,0	151,0	12,0	125,0	MFS201N-M12-151-HSK-A063-S	31184097
63	12,0	21,0	38,0	126,0	12,0	100,0	MFS201N-M12-126-HSK-A063-S	31184076
63	16,0	29,0	34,0	76,0	12,0	50,0	MFS201N-M16-076-HSK-A063-S	31184152
63	16,0	29,0	40,0	126,0	12,0	100,0	MFS201N-M16-126-HSK-A063-S	31184087
63	16,0	29,0	44,0	151,0	12,0	125,0	MFS201N-M16-151-HSK-A063-S	31184098
100	12,0	21,0	30,0	79,0	12,0	50,0	MFS201N-M12-079-HSK-A100-S	31184139
100	12,0	21,0	38,0	129,0	12,0	100,0	MFS201N-M12-129-HSK-A100-S	31184074
100	12,0	21,0	52,0	179,0	12,0	150,0	MFS201N-M12-179-HSK-A100-S	31184100
100	16,0	29,0	34,0	79,0	12,0	50,0	MFS201N-M16-079-HSK-A100-S	31184151
100	16,0	29,0	40,0	129,0	12,0	100,0	MFS201N-M16-129-HSK-A100-S	31184085
100	16,0	29,0	58,0	179,0	12,0	150,0	MFS201N-M16-179-HSK-A100-S	31184103

Available on request

63	8,0	14,0	25,0	101,0	12,0	75,0	MFS201N-M08-101-HSK-A063-S	31227420
63	10,0	18,0	30,0	101,0	12,0	75,0	MFS201N-M10-101-HSK-A063-S	31227421
63	10,0	18,0	45,0	176,0	12,0	150,0	MFS201N-M10-176-HSK-A063-S	31227410
63	12,0	21,0	35,0	101,0	12,0	75,0	MFS201N-M12-101-HSK-A063-S	31227422
63	12,0	21,0	45,0	176,0	12,0	150,0	MFS201N-M12-176-HSK-A063-S	31227411
63	16,0	29,0	35,0	101,0	12,0	75,0	MFS201N-M16-101-HSK-A063-S	31227423
63	16,0	29,0	48,0	176,0	12,0	150,0	MFS201N-M16-176-HSK-A063-S	31227412
63	16,0	29,0	50,0	226,0	12,0	200,0	MFS201N-M16-226-HSK-A063-S	31227414
63	16,0	29,0	50,0	276,0	12,0	250,0	MFS201N-M16-276-HSK-A063-S	31227418
100	8,0	14,0	23,0	79,0	12,0	50,0	MFS201N-M08-079-HSK-A100-S	31227405
100	8,0	14,0	30,0	129,0	12,0	100,0	MFS201N-M08-129-HSK-A100-S	31227398
100	10,0	18,0	25,0	79,0	12,0	50,0	MFS201N-M10-079-HSK-A100-S	31227406
100	10,0	18,0	35,0	129,0	12,0	100,0	MFS201N-M10-129-HSK-A100-S	31227399
100	10,0	18,0	45,0	179,0	12,0	150,0	MFS201N-M10-179-HSK-A100-S	31227400
100	12,0	21,0	58,0	229,0	12,0	200,0	MFS201N-M12-229-HSK-A100-S	31227401
100	12,0	21,0	62,0	279,0	12,0	250,0	MFS201N-M12-279-HSK-A100-S	31227403
100	16,0	29,0	58,0	229,0	12,0	200,0	MFS201N-M16-229-HSK-A100-S	31227402
100	16,0	29,0	66,0	279,0	12,0	250,0	MFS201N-M16-279-HSK-A100-S	31227556

Dimensions in mm.

Additional dimensions available upon request.

Scope of delivery: Without coolant tube.

Design: Permissible run-out variation of the hollow taper shank to the clamping diameter $d_1 = 3 \mu\text{m}$.

Note: Coolant tubes, see end of chapter.

Balancing quality: G 6.3 with 25,000 rpm in delivery status.

MFS milling head holder

Mechanical tool clamping

For screw-in milling cutter, made from steel

Shank hollow shank taper E according to DIN 69893-5

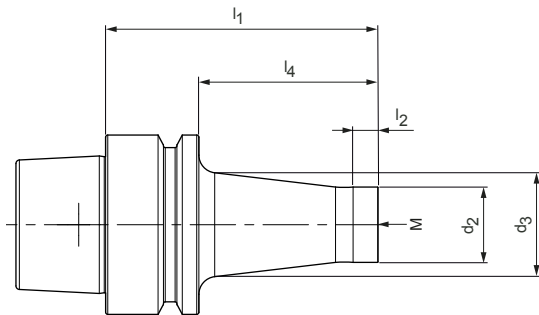

Preferred series in stock

HSK-E	Dimensions						Specification	Order no.
	M	d ₂	d ₃	l ₁	l ₂	l ₄		
50	8,0	13,8	15,0	51,0	12,0	25,0	MFS201N-M08-051-HSK-E050-S	31184113
50	8,0	13,8	23,0	76,0	12,0	50,0	MFS201N-M08-076-HSK-E050-S	31184126
50	10,0	18,0	23,0	51,0	12,0	25,0	MFS201N-M10-051-HSK-E050-S	31184114
50	10,0	18,0	25,0	76,0	12,0	50,0	MFS201N-M10-076-HSK-E050-S	31184132
50	12,0	21,0	24,0	51,0	12,0	25,0	MFS201N-M12-051-HSK-E050-S	31184115
50	12,0	21,0	30,0	76,0	12,0	50,0	MFS201N-M12-076-HSK-E050-S	31184143

Available on request

40	8,0	14,0	15,0	45,0	12,0	25,0	MFS201N-M08-045-HSK-E040-S	31227548
40	8,0	14,0	23,0	70,0	12,0	50,0	MFS201N-M08-070-HSK-E040-S	31227550
40	8,0	14,0	25,0	95,0	12,0	75,0	MFS201N-M08-095-HSK-E040-S	31227552
40	10,0	18,0	23,0	45,0	12,0	25,0	MFS201N-M10-045-HSK-E040-S	31227549
40	10,0	18,0	25,0	70,0	12,0	50,0	MFS201N-M10-070-HSK-E040-S	31227551
40	10,0	18,0	30,0	95,0	12,0	75,0	MFS201N-M10-095-HSK-E040-S	31227553

Dimensions in mm.

Additional dimensions available upon request.

Scope of delivery: Without coolant tube.

Design: Permissible run-out variation of the hollow taper shank to the clamping diameter d₁ = 3 µm.

Note: Coolant tubes, see end of chapter.

Balancing quality: G 2.5 with 25,000 rpm in delivery status.

MFS milling head holder

Mechanical tool clamping

For screw-in milling cutter, made from steel

Shank SK according to ISO 7388-1 Form AD

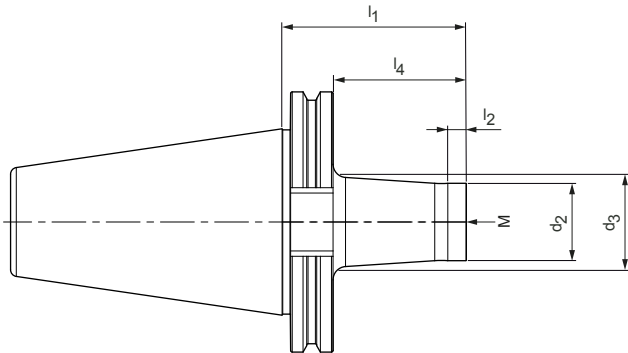

Preferred series in stock

Steep taper	Dimensions						Specification	Order no.
	M	d_2	d_3	l_1	l_2	l_4		
40	10,0	18,0	25,0	69,1	12,0	50,0	MFS201N-M10-069-SK040-S	31184128
40	10,0	18,0	35,0	119,1	12,0	100,0	MFS201N-M10-119-SK040-S	31184063
40	12,0	21,0	30,0	69,1	12,0	50,0	MFS201N-M12-069-SK040-S	31184136
40	12,0	21,0	38,0	119,1	12,0	100,0	MFS201N-M12-119-SK040-S	31184071
40	16,0	29,0	34,0	69,1	12,0	50,0	MFS201N-M16-069-SK040-S	31184147
40	16,0	29,0	40,0	119,1	12,0	100,0	MFS201N-M16-119-SK040-S	31184081
50	12,0	21,0	30,0	69,1	12,0	50,0	MFS201N-M12-069-SK050-S	31184134
50	12,0	21,0	38,0	119,1	12,0	100,0	MFS201N-M12-119-SK050-S	31184069
50	12,0	21,0	52,0	169,1	12,0	150,0	MFS201N-M12-169-SK050-S	31184099
50	16,0	29,0	34,0	69,1	12,0	50,0	MFS201N-M16-069-SK050-S	31184145
50	16,0	29,0	40,0	119,1	12,0	100,0	MFS201N-M16-119-SK050-S	31184079
50	16,0	29,0	48,0	169,1	12,0	150,0	MFS201N-M16-169-SK050-S	31184101

Available on request

40	8,0	14,0	23,0	69,1	12,0	50,0	MFS201N-M08-069-SK040-S	31227376
40	8,0	14,0	25,0	94,1	12,0	75,0	MFS201N-M08-094-SK040-S	31227377
40	8,0	14,0	30,0	119,1	12,0	100,0	MFS201N-M08-119-SK040-S	31227363
40	10,0	18,0	30,0	94,1	12,0	75,0	MFS201N-M10-094-SK040-S	31227378
40	10,0	18,0	45,0	169,1	12,0	150,0	MFS201N-M10-169-SK040-S	31227367
40	12,0	21,0	35,0	94,1	12,0	75,0	MFS201N-M12-094-SK040-S	31227379
40	12,0	21,0	48,0	169,1	12,0	150,0	MFS201N-M12-169-SK040-S	31227368
40	16,0	29,0	35,0	94,1	12,0	75,0	MFS201N-M16-094-SK040-S	31227380
40	16,0	29,0	48,0	169,1	12,0	150,0	MFS201N-M16-169-SK040-S	31227369
50	10,0	18,0	25,0	69,1	12,0	50,0	MFS201N-M10-069-SK050-S	31227558
50	10,0	18,0	30,0	94,1	12,0	75,0	MFS201N-M10-094-SK050-S	31227559
50	10,0	18,0	35,0	119,1	12,0	100,0	MFS201N-M10-119-SK050-S	31227554
50	10,0	18,0	45,0	169,1	12,0	150,0	MFS201N-M10-169-SK050-S	31227555

Dimensions in mm.

Additional dimensions available upon request.

Scope of delivery: Without pull stud.

Design: Permissible run-out variation of the hollow taper shank to the clamping diameter $d_1 = 3 \mu\text{m}$.

Note: Pull stud, see end of chapter.

Balancing quality: G 16 with 8,000 rpm in delivery status.

MFS milling head holder

Mechanical tool clamping

For screw-in milling cutter, made from steel

Shank BT according to ISO 7388-2 Form JD/JF (JIS B 6339)

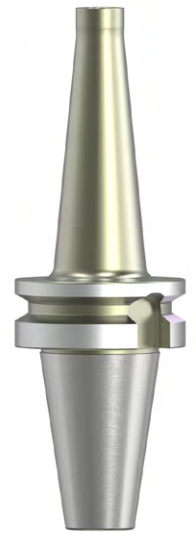
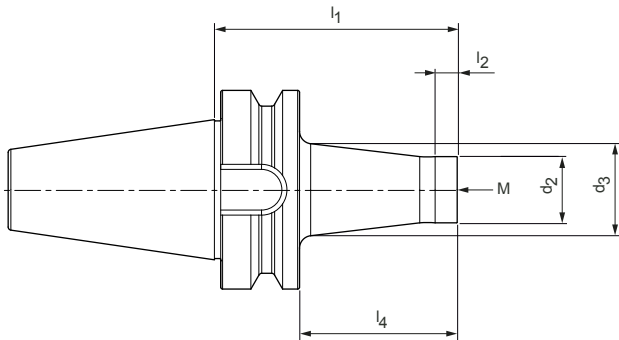

Available on request

BT	Dimensions						Specification	Order no.
	M	d_2	d_3	l_1	l_2	l_4		
40	8,0	14,0	23,0	77,0	12,0	50,0	MFS201N-M08-077-BT040-S	31227390
40	8,0	14,0	30,0	127,0	12,0	100,0	MFS201N-M08-127-BT040-S	31227381
40	10,0	18,0	25,0	77,0	12,0	50,0	MFS201N-M10-077-BT040-S	31227391
40	10,0	18,0	35,0	127,0	12,0	100,0	MFS201N-M10-127-BT040-S	31227382
40	12,0	21,0	30,0	77,0	12,0	50,0	MFS201N-M12-077-BT040-S	31227392
40	12,0	21,0	38,0	127,0	12,0	100,0	MFS201N-M12-127-BT040-S	31227383
40	16,0	29,0	34,0	77,0	12,0	50,0	MFS201N-M16-077-BT040-S	31227393
40	16,0	29,0	40,0	127,0	12,0	100,0	MFS201N-M16-127-BT040-S	31227384
50	12,0	21,0	30,0	88,0	12,0	50,0	MFS201N-M12-088-BT050-S	31227440
50	12,0	21,0	38,0	138,0	12,0	100,0	MFS201N-M12-138-BT050-S	31227430
50	16,0	29,0	34,0	88,0	12,0	50,0	MFS201N-M16-088-BT050-S	31227441
50	16,0	29,0	40,0	138,0	12,0	100,0	MFS201N-M16-138-BT050-S	31227431

Dimensions in mm.

Additional dimensions available upon request.

Scope of delivery: Without pull stud.

Design: Permissible run-out variation of the hollow taper shank to the clamping diameter $d_1 = 3 \mu\text{m}$.

Note: Pull stud, see end of chapter.

Balancing quality: G 16 with 8,000 rpm in delivery status.

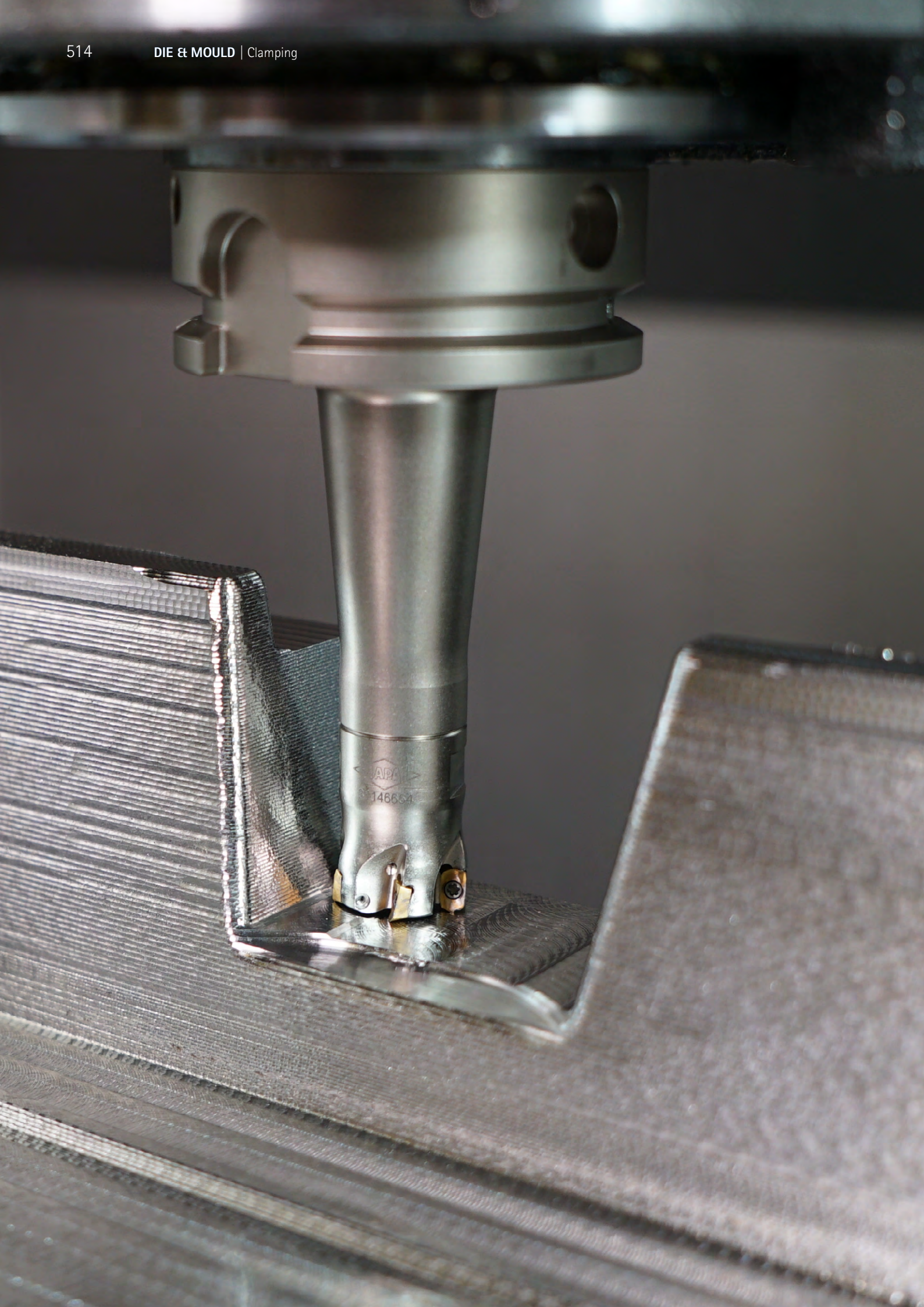

Solid carbide extensions for screw-in tool

Mechanical tool clamping

For screw-in milling cutter made from solid carbide

Cylindrical shank according to DIN 1835-A

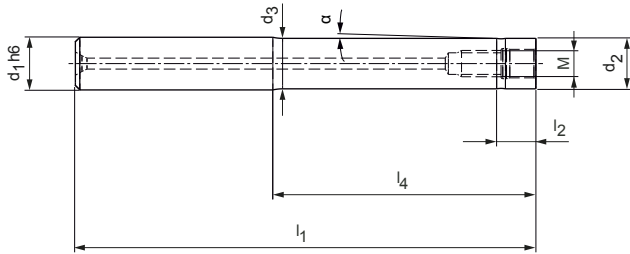

Preferred series in stock

Dimensions								Internal cooling	Specification	Order no.
M	d ₁ h6	d ₂	d ₃	l ₁	l ₄	l ₂	α			
4,5	10,0	7,7	10,0	65,0	20,0	-	-	✓	MFS101-45-020-ZYL-HA10-H	31217761
4,5	10,0	7,7	10,0	85,0	40,0	-	1,65°	✓	MFS101-45-040-ZYL-HA10-H	31217755
4,5	10,0	7,7	10,0	105,0	60,0	-	1,1°	✓	MFS101-45-060-ZYL-HA10-H	31217757
4,5	10,0	7,7	10,0	130,0	80,0	-	0,82°	✓	MFS101-45-080-ZYL-HA10-H	31217758
4,5	10,0	7,7	10,0	150,0	100,0	-	0,66°	✓	MFS101-45-100-ZYL-HA10-H	31217760
6	10,0	9,5	10,0	60,0	20,0	9,0	0,72°	✓	MFS101-06-020-ZYL-HA10-H	31166769
6	10,0	9,5	10,0	80,0	40,0	9,0	0,36°	✓	MFS101-06-040-ZYL-HA10-H	31166770
6	10,0	9,5	10,0	100,0	60,0	9,0	0,24°	✓	MFS101-06-060-ZYL-HA10-H	31166771
6	10,0	9,5	10,0	120,0	80,0	9,0	0,18°	✓	MFS101-06-080-ZYL-HA10-H	31166772
8	16,0	12,8	16,0	95,0	40,0	-	2,29°	✓	MFS101-08-040-ZYL-HA16-H	31166749
8	16,0	12,8	16,0	115,0	60,0	-	1,53°	✓	MFS101-08-060-ZYL-HA16-H	31166750
8	16,0	12,8	16,0	135,0	80,0	-	1,15°	✓	MFS101-08-080-ZYL-HA16-H	31166751
8	16,0	12,8	16,0	155,0	100,0	-	0,92°	✓	MFS101-08-100-ZYL-HA16-H	31166752
8	16,0	12,8	16,0	175,0	120,0	-	0,76°	✓	MFS101-08-120-ZYL-HA16-H	31166753
10	20,0	17,8	20,0	100,0	40,0	-	1,58°	✓	MFS101-10-040-ZYL-HA20-H	31166754
10	20,0	17,8	20,0	120,0	60,0	-	1,05°	✓	MFS101-10-060-ZYL-HA20-H	31166755
10	20,0	17,8	20,0	140,0	80,0	-	0,79°	✓	MFS101-10-080-ZYL-HA20-H	31166756
10	20,0	17,8	20,0	160,0	100,0	-	0,63°	✓	MFS101-10-100-ZYL-HA20-H	31166757
10	20,0	17,8	20,0	180,0	120,0	-	0,53°	✓	MFS101-10-120-ZYL-HA20-H	31166758
12	25,0	23,0	24,3	136,0	80,0	9,0	0,591°	✓	MFS101-12-080-ZYL-HA25-H	31166759
12	25,0	23,0	24,3	156,0	100,0	9,0	0,449°	✓	MFS101-12-100-ZYL-HA25-H	31166760
12	25,0	23,0	24,3	176,0	120,0	9,0	0,362°	✓	MFS101-12-120-ZYL-HA25-H	31166761
12	25,0	23,0	24,3	196,0	140,0	9,0	0,303°	✓	MFS101-12-140-ZYL-HA25-H	31166762
12	25,0	23,0	24,3	216,0	160,0	9,0	0,260°	✓	MFS101-12-160-ZYL-HA25-H	31166763
16	32,0	29,0	31,5	160,0	100,0	9,0	0,828°	✓	MFS101-16-100-ZYL-HA32-H	31166764
16	32,0	29,0	31,5	210,0	150,0	9,0	0,517°	✓	MFS101-16-150-ZYL-HA32-H	31166765
16	32,0	29,0	31,5	260,0	200,0	9,0	0,376°	✓	MFS101-16-200-ZYL-HA32-H	31166766

Available on request

16	32,0	29,0	31,5	310,0	250,0	9,0	0,295°	✓	MFS101-16-250-ZYL-HA32-H	31166767
16	32,0	29,0	31,5	360,0	300,0	9,0	0,243°	✓	MFS101-16-300-ZYL-HA32-H	31166768

Tool extension for thermal expanding chucks

With axial tool length adjustment from clamping diameter $d_1 = 6 \text{ mm}$
Cylindrical shank according to DIN 1835-A



Cylindrical shank mounting diameter D	Dimensions							G	Specification	Order no.
	d_1	d_2	d_3	l_1	l_2	l_3	l_4			
12	3,0	8,0	11,6	150,0	12,0	-	22,9	-	12X3X150	30251111
12	4,0	8,0	11,6	150,0	16,0	-	22,9	-	12X4X150	30251112
12	5,0	10,0	11,6	150,0	20,0	-	10,2	-	12X5X150	30251113
12	6,0	10,0	11,6	150,0	36,0	10,0	10,2	M5	12X6X150	30251114
16	3,0	10,0	15,6	150,0	12,0	-	35,6	-	16X3X150	30251115
16	4,0	10,0	15,6	150,0	16,0	-	35,6	-	16X4X150	30251116
16	5,0	10,0	15,6	150,0	20,0	-	35,6	-	16X5X150	30251117
16	6,0	10,0	15,6	150,0	36,0	10,0	35,6	M5	16X6X150	30251118
16	8,0	12,0	15,6	150,0	36,0	10,0	22,9	M6	16X8X150	30251119
20	3,0	10,0	19,6	150,0	12,0	-	61,0	-	20X3X150	30251120
20	4,0	10,0	19,6	150,0	16,0	-	61,0	-	20X4X150	30251121
20	5,0	10,0	19,6	150,0	20,0	-	61,0	-	20X5X150	30251122
20	6,0	10,0	19,6	150,0	36,0	10,0	61,0	M5	20X6X150	30251123
20	8,0	12,0	19,6	150,0	36,0	10,0	48,3	M6	20X8X150	30251124
20	10,0	14,0	19,6	150,0	41,0	10,0	35,6	M8x1	20X10X150	30251125
20	12,0	16,0	19,6	150,0	47,0	10,0	22,9	M10x1	20X12X150	30251126
25	6,0	20,0	24,6	150,0	36,0	10,0	29,2	M5	25X6X150	30251130
25	8,0	20,0	24,6	150,0	36,0	10,0	29,2	M6	25X8X150	30251131
25	10,0	20,0	24,6	150,0	41,0	10,0	29,2	M8x1	25X10X150	30251132
25	12,0	20,0	24,6	150,0	47,0	10,0	29,2	M10x1	25X12X150	30251133
25	14,0	20,0	24,6	150,0	47,0	10,0	29,2	M10x1	25X14X150	30251134
25	16,0	22,0	24,6	150,0	50,0	10,0	16,5	M10x1	25X16X150	30251135
32	6,0	20,0	29,0	150,0	36,0	10,0	56,7	M5	32X6X150	30251136
32	8,0	20,0	29,0	150,0	36,0	10,0	56,7	M6	32X8X150	30251137
32	10,0	24,0	31,6	150,0	41,0	10,0	48,3	M8x1	32X10X150	30251138
32	12,0	24,0	31,6	150,0	47,0	10,0	48,3	M10x1	32X12X150	30251139
32	14,0	27,0	31,6	150,0	47,0	10,0	29,2	M10x1	32X14X150	30251140
32	16,0	27,0	31,6	150,0	50,0	10,0	29,2	M10x1	32X16X150	30251141
32	18,0	27,0	31,6	150,0	50,0	10,0	29,2	M10x1	32X18X150	30251142
32	20,0	27,0	31,6	150,0	52,0	10,0	29,2	M10x1	32X20X150	30251143

Dimensions in mm.

Extensions may only be shortened on the shank.

The minimum clamping depth required is $2-3 \times D$.

The clamping diameter is designed for a shank tolerance of h6. We assume no liability for changes to tool adapters and the consequences of this.

Coolant tubes, blind screws

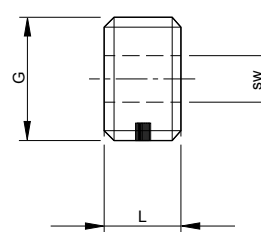
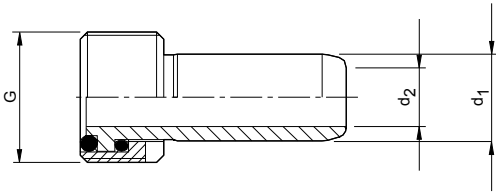

Coolant tubes according to DIN 69895

HSK	Dimensions			Order no.
	G	d ₁	d ₂	
32	M10x1	6	3,5	30326003
40	M12x1	8	5	30326004
50	M16x1	10	6,4	30326005
63	M18x1	12	8	30326006
80	M20x1,5	14	10	30326007
100	M24x1,5	16	12	30326008

Blind screws

HSK	Dimensions			Order no.
	G	L	sw	
32	M10x1	5,5	4	30326075
40	M12x1	7,5	5	30326076
50	M16x1	9,5	6	30326077
63	M18x1	11,5	8	30326078
80	M20x1,5	13,5	10	30326079
100	M24x1,5	15,5	12	30326074

Dimensions in mm.

Scope of delivery: Coolant tube with two O-rings and clamping nut.
 Design: Smooth angular movement 1° self-centering, axially sealed.
 Note: Designed according to DIN 69895. Tightness tested to 80 bar.
 Use: For closing the thread bore in hollow shank taper tool shanks if no coolant tube is used.
 Design: With Nylok insert for screw retention.

Workpiece material: Corrosion-resistant steel.

Pull studs for steep taper adapter

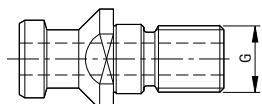

Pull studs for taper shank according to ISO 7388-3 Form AD/AF

Steep taper	Shape	G	Order no.
30	AD	M12	10017955
30	AF	M12	10061282
40	AD	M16	10004416
40	AF	M16	10007995
50	AD	M24	10006581
50	AF	M24	10021618

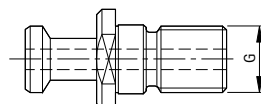

Pull studs for taper shank according to ISO 7388-3 Form JD 30°/45°

BT	Shape	G	Order no.
30	30°	M12	10017954
30	45°	M12	10066211
40	30°	M16	10022405
40	45°	M16	10018129
50	30°	M24	10020619
50	45°	M24	10013983

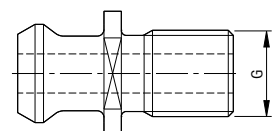

Pull studs for taper shank in accordance with ASME B 5.50 (CAT)

CAT	G	Order no.
40	5/8" - UNC	10066206
50	1" - UNC	10066210

Spare parts for milling cutter arbors

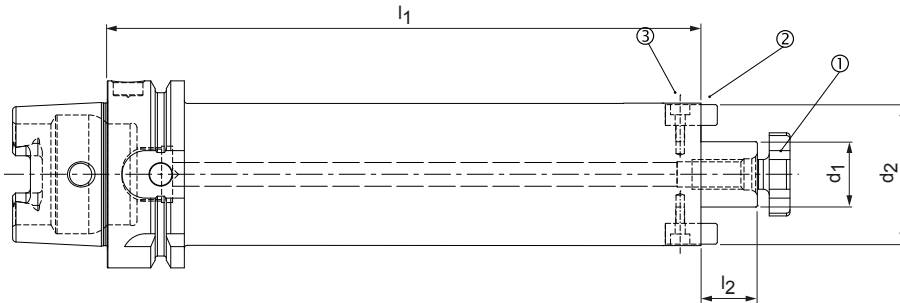

For milling cutter arbors with enlarged face connection diameter according to DIN 69882-3

Connection HSK-A	For arbor diameter d_1	① Milling cutter clamping screw according to DIN 6367		③ Cylinder screw according to ISO 4762 (2x)	
		Size	Order no.	Size	Order no.
63	16	M12	10005164	M4x12-12.9	10003584
63	22	M10	10006016	M3x8-12.9	10003570
100	16	M12	10005164	M4x12-12.9	10003584
100	22	M10	10006016	M3x8-12.9	10003570
100	27	M8	10007286	M3x8-12.9	10003570

For milling cutter arbors with enlarged face connection diameter according to DIN 69882-3

Connection Steep taper	For arbor diameter d_1	① Milling cutter clamping screw according to DIN 6367		③ Cylinder screw according to ISO 4762 (2x)	
		Size	Order no.	Size	Order no.
40	16	M12	10005164	M4x12-12.9	10003584
40	22	M10	10006016	M3x8-12.9	10003570
50	16	M12	10005164	M4x12-12.9	10003584
50	22	M10	10006016	M3x8-12.9	10003570
50	27	M8	10007286	M3x8-12.9	10003570

Reducing sleeve for hydraulic chuck

Without length adjustment, coolant density

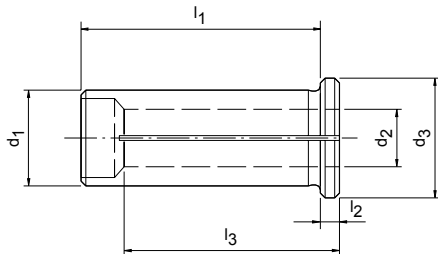

Dimensions						Order no.
d ₁	d ₂	d ₃	l ₁	l ₂	l ₃	
12	3	16	40	4	29	30251059
12	4	16	40	4	29	30251060
12	5	16	40	4	29	30251061
12	6	16	40	4	36	30251062
12	7	16	40	4	37	30251063
12	8	16	40	4	37	30251064
12	9	16	40	4	37	30251065
12	10	16	40	4	40	30251066
20	3	25	50	4	28	30251067
20	4	25	50	4	28	30251068
20	5	25	50	4	28	30251069
20	6	25	50	4	36	30251070
20	7	25	50	4	38	30251071
20	8	25	50	4	37	30251072
20	9	25	50	4	38	30251073
20	10	25	50	4	40	30251074
20	11	25	50	4	40	30251075
20	12	25	50	4	45	30251076
20	13	25	50	4	45	30251077
20	14	25	50	4	45	30251078
20	15	25	50	4	45	30251079
20	16	25	50	4	48	30251080
20	18	25	50	4	48	30486538
25	3	30	56	4	29	30251081
25	4	30	56	4	29	30251082
25	5	30	56	4	29	30251083
25	6	30	56	4	37	30251084
25	7	30	56	4	37	30251085
25	8	30	56	4	37	30251086
25	9	30	56	4	38	30251087
25	10	30	56	4	40	30251088
25	12	30	56	4	46	30251089

Reducing sleeve for hydraulic chuck | without length adjustment, coolant seal

Dimensions						Order no.
d ₁	d ₂	d ₃	l ₁	l ₂	l ₃	
25	14	30	56	4	47	30251090
25	16	30	56	4	48	30251091
25	18	30	56	4	48	30251092
25	20	30	56	4	50	30251093
32	6	36	60	4	36	30251094
32	7	36	60	4	37	30251095
32	8	36	60	4	36	30251096
32	9	36	60	4	37	30251097
32	10	36	60	4	40	30251098
32	11	36	60	4	40	30251099
32	12	36	60	4	45	30251100
32	13	36	60	4	45	30251101
32	14	36	60	4	46	30251102
32	15	36	60	4	46	30251103
32	16	36	60	4	48	30251104
32	17	36	60	4	48	30251105
32	18	36	60	4	49	30251106
32	19	36	60	4	49	30251107
32	20	36	60	4	50	30251108
32	22	36	60	4	50	30251109
32	25	36	60	4	56	30251110

Dimensions in mm.

Design: Suitable for tap drills in accordance with DIN, ISO and JIS standards.

Note: Never clamp shanks with oversize! E.g. never press a shank with \varnothing 9.2 mm into a collet with \varnothing 9.0 mm. Use the next collet size up (here \varnothing 10.0 mm).

Instructions for handling the milling cutter arbor with vibration damper

Mounting a tool

Note:

Whenever you change tools, make sure that all components of the milling cutter arbor and tool are free of dirt, grease and damage.



1. Clean the connection areas of the milling cutter arbor and the tool (1).



2. Clamp the milling cutter arbor in a changing device.

3. Place the tool, with bore and face connection in front, on the face connection of the milling cutter arbor.
 → The key block slot of the tool is positioned on the key block of the milling cutter arbor.



4. Lightly screw the milling cutter clamping screw into the thread bore of the milling cutter arbor by hand.



5. Adjust a torque wrench to the tightening torque required by the milling cutter manufacturer.
 6. Use the torque wrench to tighten the milling cutter clamping screw until it stops.

Result:

The tool is clamped onto the milling cutter arbor with the milling cutter clamping screw and can be used.



Removing a tool



1. Loosen the milling cutter clamping screw, for example by using the torque wrench.



2. Unscrew the milling cutter clamping screw from the thread bore and remove it.



3. Remove the tool from the milling cutter arbor.

Result:
The tool has been removed.

Instructions on how to handle the Mill Chuck, HB mill chuck

Clamping a tool

Note:

Only clamp undamaged tools and tools that are free from burrs.

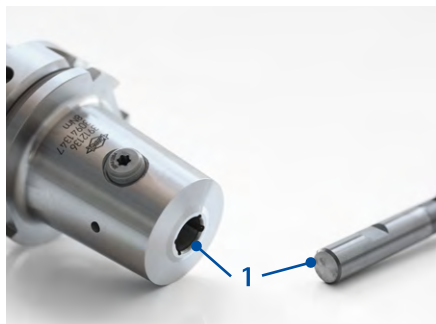

1. Clean the location bore and the tool shank (position 1).



Note:

To ensure correct tool clamping, the HB surface of the tool must face the clamping screw.

2. Push the tool, starting with the shank, into the location bore of the side lock chuck. The recess on the tool must be directed towards the clamping screw.

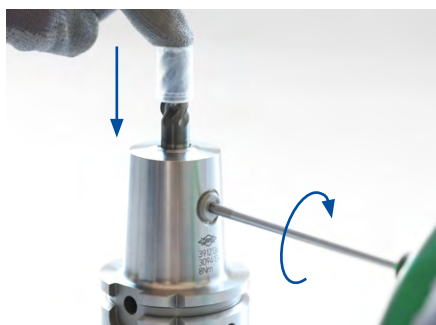

3. Press on the tool from above. At the same time, turn the clamping screw clockwise until it stops.
→ The clamping screw is abut with the HB surface of the tool.

4. Turn the clamping screw back half a turn.



5. Set a torque wrench to the specified tightening torque (see table "Tightening torques for the clamping screw" on page 525).

6. Tighten the clamping screw until it stops using the torque wrench.

Comment:

- For trained personnel only.
- Wear protective gloves.
- It is recommended that you handle the tool with a protective cap.

Result:

The tool is completely clamped in the side lock chuck and can be used.

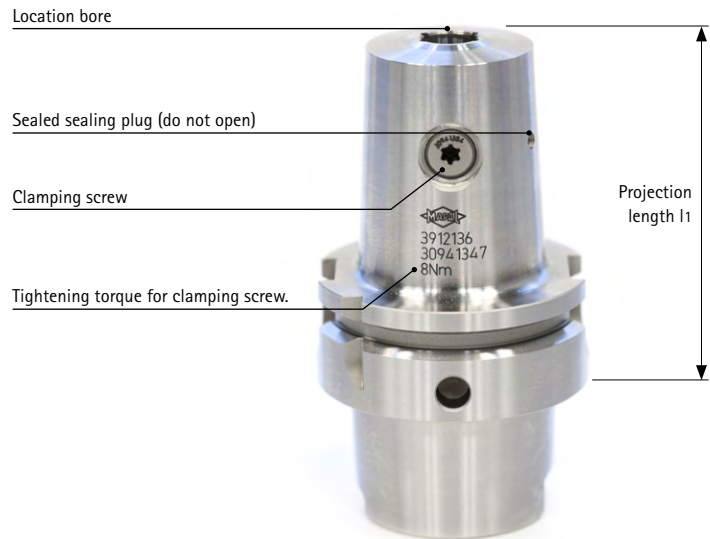

Unclamping a tool

Note:

The clamping screw is not secured from accidentally falling out.



1. Loosen the clamping screw by turning it anticlockwise.



2. Remove the tool from the side lock chuck's location bore.

Result:

The tool has been removed.

Tightening torques for clamping screw

Tool shank diameter [mm]	Tightening torque [Nm]
6	10
8	10
10	7
12	13
16	23
20	25
25	47
32	50

Hydraulic clamping technology

1. Hydraulic clamping technology elements

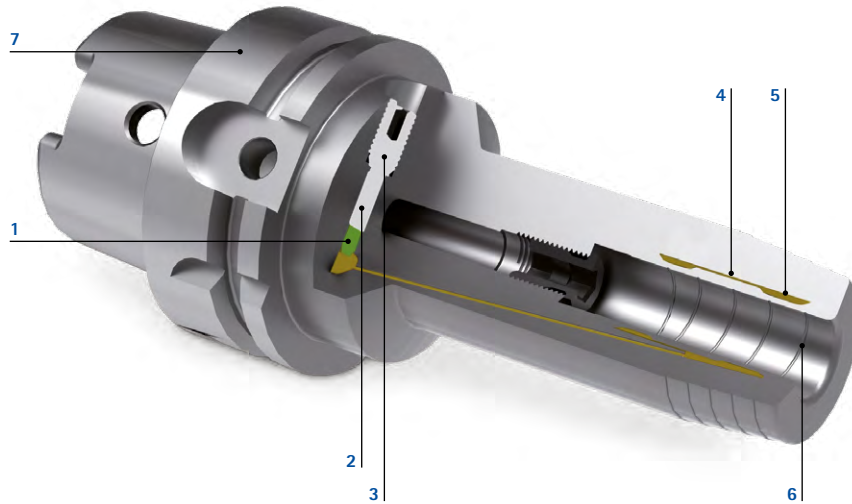

When clamping with the hydraulic clamping technology, even pressure is built up within a closed chamber system using a clamping screw and a piston. This pressure is transmitted to the tool via the built-in expanding sleeve.

- 1 Sealing element**
High levels of leakage at the clamping bore are prevented by the lip seal.
- 2 Piston**
Presses the hydraulic medium into the chamber system.
- 3 Clamping screw**
The clamping piston can be actuated without a torque wrench.
- 4 Expanding sleeve**
This clamps the tool shank centrally by distributing pressure evenly.
- 5 Chamber system**
This results from the connection of the expanding sleeve and the tool body. Has a damping effect on the tool thanks to the hydraulic medium and, in this way, reduces wear and tear.
- 6 Groove**
Oil, grease or lubricant residues are displaced into the groove by the high clamping pressure. The clamping surfaces remain largely dry and the transmission of the torques is guaranteed.
- 7 Tool body**
MAPAL hydraulic chucks are available for all common machine-side connections (HSK-A, HSK-C, HSK-E, HSK-F, SK, BT and flange module).

2. Operating principle

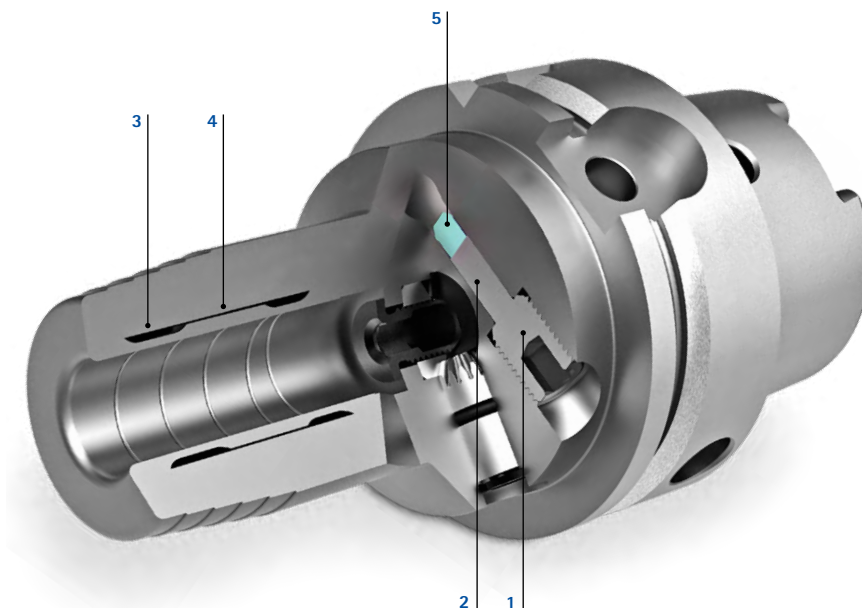

- 1** The clamping screw is screwed in to the stop using a hex-wrench.
- 2** The piston presses the hydraulic medium into the
- 3** expansion chamber and causes the pressure to increase.
- 4** The thin-walled expanding sleeve bows evenly against the tool shank. The tool shank is centred and then clamped powerfully and uniformly across its entire surface during this clamping process.
- 5** The sealing element ensures absolute freedom from leaks and a long tool life.

Technical data

- Workpiece material 1600-1800 N/mm² tensile strength
- Distance adjustment 10 mm
- Hardness 52 + 2 HRC
- DIN 1835 Form A, B, C, D
- Balanced tool holder
- DIN 6535 Form HA, HB, HE
- Laser marking
- Coolant pressure maximum 80 bar
- Max. spindle speed 40,000 rpm (note spindle speed limit for connection, fine balancing recommended!)
- Optimal operating temperature 20 - 80 °C; higher temperatures can be used upon request; do not use above 80 °C
- Shanks suitable for clamping (tolerance h6) with and without reducing sleeves:
 - DIN 1835 Form A, B, E
 - DIN 6535 Form HA, HB, HE

3. Radial tool length adjustment

MAPAL offers hydraulic chucks with radial tool length adjustment for clamping tools with hollow shank taper connections. Even with this adjustment method, radial run-out accuracies of $\leq 3 \mu\text{m}$ are guaranteed.

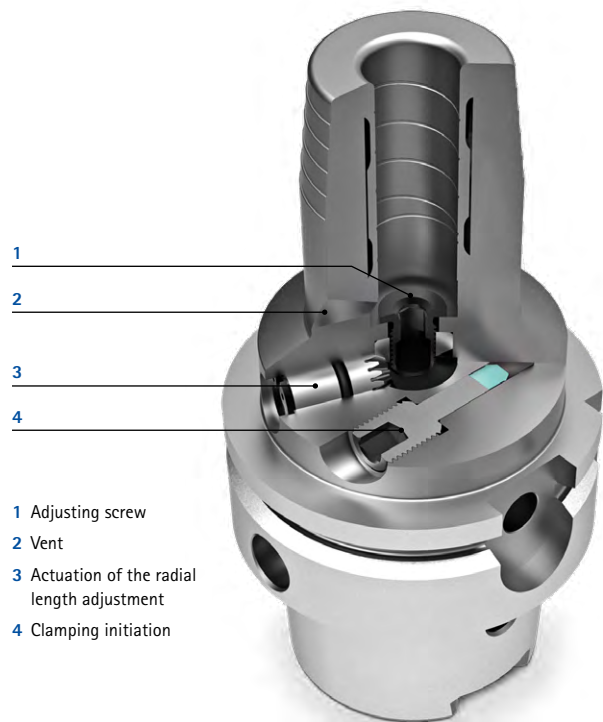

4. Additive-manufactured hydraulic clamping technology

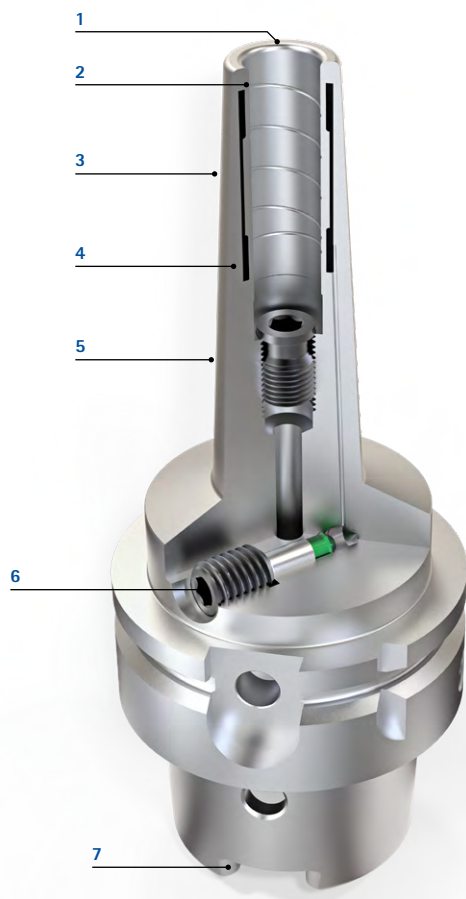

- 1 Optimal radial run-out as the clamping range is located close to the chuck tip
- 2 High torque transmission and thermal stability
- 3 A back taper of 3° in the outside contour allows machining in contour-critical areas
- 4 All-in-one casting – no brazed connection between sleeve and tool body
- 5 High flexural strength despite slender design
- 6 Quick and simple clamping thanks to hexagon head screw
- 7 Optionally with dynamically balanced hollow shank taper

Hydraulic clamping technology

5. Torque transmission and minimum clamping depth

Please use the respective transmittable torque and the minimum clamping depth from the table.

The specified torques are valid for cylindrical shanks according to DIN 6535 Form A and DIN 1835.

HighTorque Chuck - HTC

Slim design 3 degrees at operating temperature: 20-80 °C

Clamping diameter [mm]	Minimum clamping depth [mm]	Permissible transferable torque [Nm] *	Max. operating speed [min ⁻¹]	
			l ₁ ≤ 125 mm	l ₁ > 125 mm
3	12	3	40.000	20.000
4	16	6		
5	20	10		
6	27	20		
7	27	20		
8	27	35		
9	31	50		
10	31	65		
11	31	85		
12	36	110		
13	36	110	20.000	10.000
14	36	120		
16	39	160		
18	39	200		
20	41	260		

Short and long heavy-duty design

Clamping diameter [mm]	Minimum clamping depth [mm]	Permissible transferable torque [Nm] *	Max. operating speed [min ⁻¹]	
			l ₁ ≤ 125 mm	l ₁ > 125 mm
6	27	30	40.000	20.000
8	27	50		
10	31	100		
12	36	150		
14	36	210		
16	39	280		
18	39	360	20.000	10.000
20	41	550		
32	51	900		

HydroChuck - MHC

Clamping diameter [mm]	Minimum clamping depth [mm]	Permissible transferable torque [Nm] *	Max. operating speed [min ⁻¹]	
			l ₁ ≤ 125 mm	l ₁ > 125 mm
6	27	20	40.000	20.000
8	27	35		
10	31	50		
12	36	90		
14	36	120		
16	39	170		
18	39	240	20.000	10.000
20	41	330		

Dimensions in mm.

* For shank h6 minimum.

Shrinking technology

Shrinking technology uses thermal expansion for tool clamping. An induction coil heats the shrink chuck. The chuck expands and the cold tool shank can be inserted. The shrink chuck is cooled down again, contracts and forms a force-locking connection with the tool due to the oversize of the tool shank.

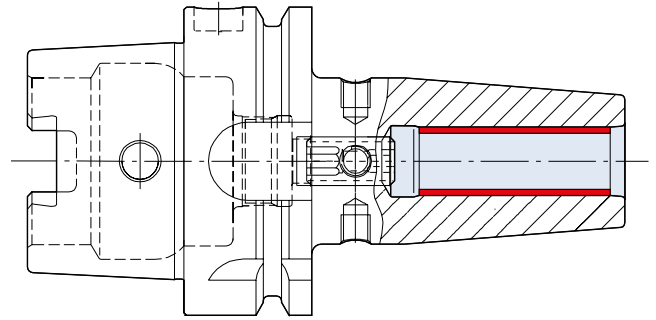

Operating principle

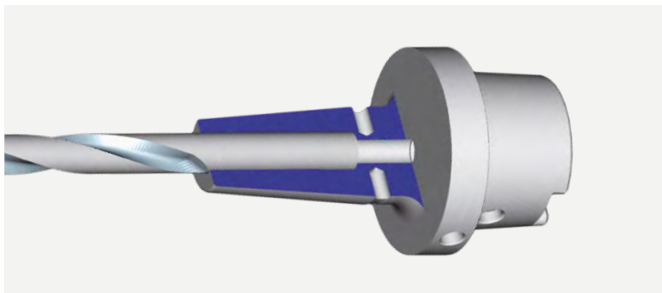
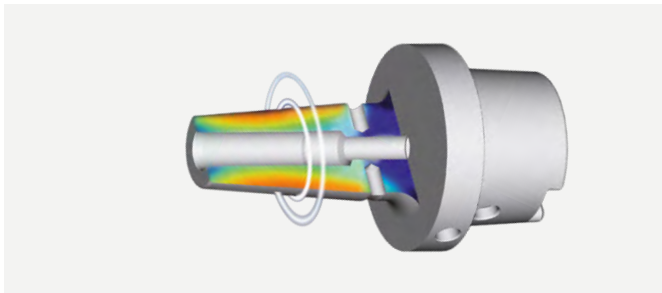

1. Heating up the chuck

The chuck is heated at the clamping point using the latest induction technology. An induction coil generates rapidly changing eddy currents that act directly on the shrink chuck and heat it up exactly where the tool shank is located. The bore diameter increases.

2. Inserting the tool shank

The cold tool shank is inserted into the heated shrink chuck.

3. Cooling down

The shrink chuck is cooled down and the clamping diameter returns to its original dimension and clamps the tool shank. A powerful unit with water-cooled cooling elements enables rapid cooling within 30 seconds. This prevents the taper and data chip from overheating. Adapters that can be inserted into the cooling element enable the cooling of extensions and non-standard shrink chucks.

The result

Due to the inductive heating, tool changes can now be carried out within seconds. The shrink chuck and tool shank form a force-locking connection. Both carbide and HSS tools can be clamped. The tool is clamped precisely in the tool adapter with the maximum clamping force.

Torque transmission and minimum clamping depth

ThermoChuck – MTC

Clamping diameter [mm]	Minimum clamping depth [mm]	Permissible transferable torque with shank Smallest size h6 [Nm]
4	16	11
6	26	24
8	26	45
10	31	82
12	37	145
16	40	400
20	42	450
25	48	530
32	52	700

Please use the respective transmittable torque and the minimum clamping depth from the table.

The specified torques are valid for cylindrical shanks according to DIN 6535 Form A and DIN 1835.

Hollow shank taper standard

For hollow shanks, DIN 69893-1 HSK-A and HSK-C

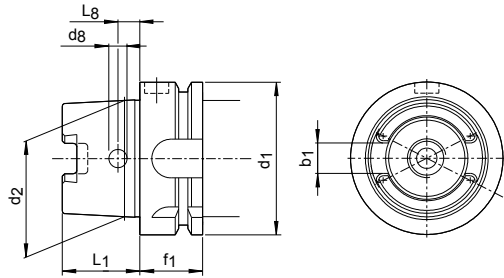

HSK-A
for automatic and manual tool change

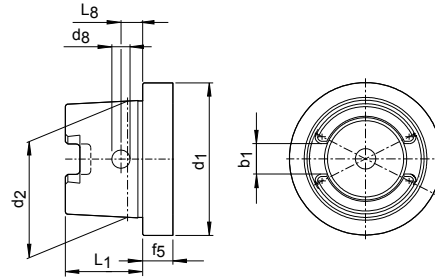

HSK-C
for manual tool change

		Hollow shank taper size					
Nominal size	d_1 h10	32	40	50	63	80	100
Taper diameter	d_2	24,007	30,007	38,009	48,01	60,012	75,013
Shank length	L_1 0/-0,2	16	20	25	32	40	50
Groove width	b_1 +/-0,04	7,05	8,05	10,54	12,54	16,04	20,02
Bore diameter	d_8	4	4,6	6	7,5	8,5	12
Bore spacing	L_8 +/-0,1	5	6	7,5	9	12	15
Flange width hollow shank taper A	f_1 0/-0,1	20	20	26	26	26	29
Flange width hollow shank taper C	f_5	10	10	12,5	12,5	16	16

For connections, DIN 69063-1 HSK-A and HSK-C

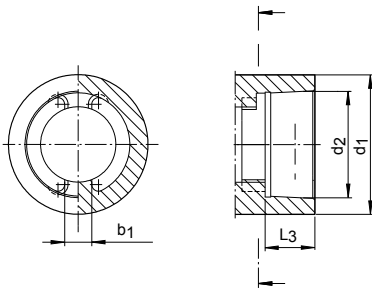

HSK-A
for automatic tool change

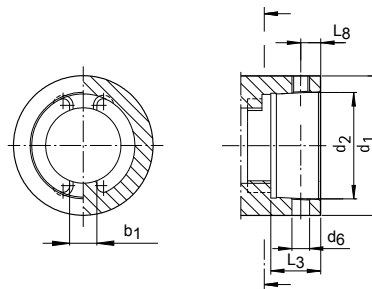

HSK-C
for manual tool change

		Hollow shank taper size					
Nominal size	d_1	32	40	50	63	80	100
Taper diameter	d_2	23,998	29,998	37,998	47,998	59,997	74,997
Depth	L_3 +0,2	11,4	14,4	17,9	22,4	28,4	35,4
Driving element width	b_1 +/-0,05	6,8	7,8	10,3	12,3	15,8	19,78

Also with hollow shank taper C

Bore diameter	d_6	4	5	6	8	9	11
Bore spacing	L_8 +/-0,1	5	6	7,5	9	12	15

Hollow shank taper standard

For hollow shanks, DIN 69893-5 HSK-E

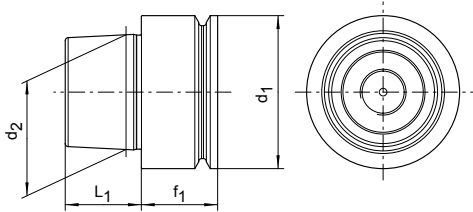

Hollow shank taper form E (HSK-E)
for automatic tool change

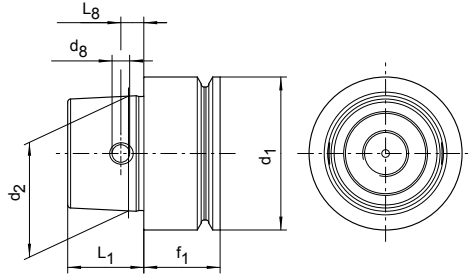

Hollow shank taper form E (HSK-E)
for automatic and manual tool change

	Hollow shank taper size					
Nominal size	d_1 h10	25	32	40	50	63
Taper diameter	d_2	19,006	24,007	30,007	38,009	48,01
Shank length	L_1 0/-0,2	13	16	20	25	32
Bore diameter	d_8	3,7	4	4,6	6	7,5
Bore spacing	L_8 +/-0,1	4	5	6	7,5	9
Flange width hollow shank taper E	f_1 0/-0,1	10	20	20	26	26

For connections, DIN 69063-5, HSK-E

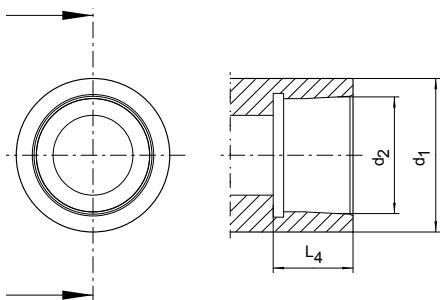

Hollow shank taper form E (HSK-E)
for automatic tool change

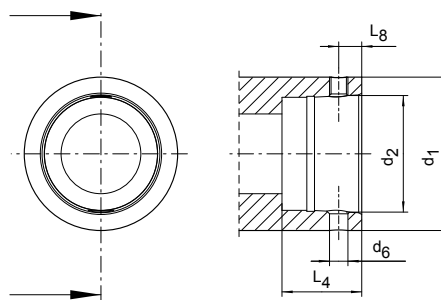

Hollow shank taper form E (HSK-E)
for manual tool change

	Hollow shank taper size					
Nominal size	d_1	25	32	40	50	63
Taper diameter	d_2	18,998	23,998	29,998	37,998	47,998
Depth	L_4 +0,2	13,5	16,5	20,5	25,5	33
Bore diameter	d_6	4	4,5	5	6	8
Bore spacing	L_8 +/-0,1	4	5	6	7,5	9

Dimensions in mm.

Steep taper standard

For steep taper tool shanks according to ISO 7388-1

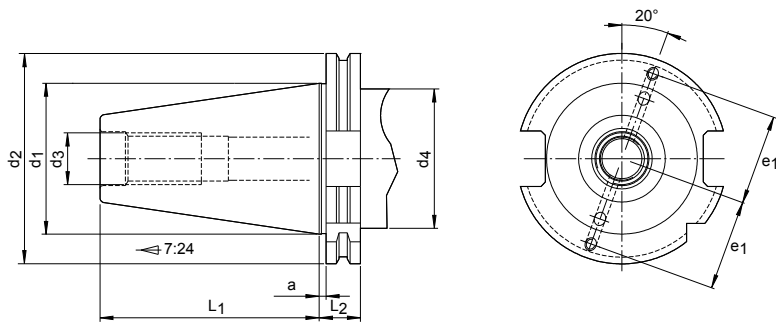

For automatic tool change Form A, Form AD, Form AF and design with data carrier

	Size			
	30	40	45	50
a $\pm 0,1$	3,2	3,2	3,2	3,2
d ₁	31,75	44,45	57,15	69,85
d ₂ 0/-0,1	50	63,55	82,55	97,5
d ₃	M 12	M 16	M 20	M 24
d ₄ max.	45	50	63	80
e ₁ $\pm 0,1$	21	27	35	42
L ₁ 0/-0,3	47,8	68,4	82,7	101,75
L ₂ 0/-0,1	19,1	19,1	19,1	19,1

BT standard

For BT tool shanks according to ISO 7388-2

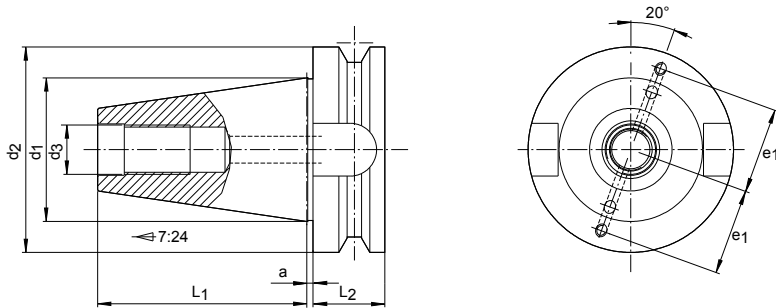

For automatic tool change Form J, Form JF, Form JD and design with data carrier

	Size		
	30	40	50
$a \pm 0,4^*$	2	2	3
d_1	31,75	44,45	69,85
$d_2 \text{ h}8$	46	63	100
d_3	M 12	M 16	M 24
$e_1 \pm 0,1$	20	27	42
$L_1 \pm 0,2$	48,4	65,4	101,8
$L_2 \text{ min.}$	22	27	38



You can find the complete MAPAL portfolio in our catalogue
"SETTING | MEASURING | DISPENSING"

Can now be browsed and downloaded
as a PDF at www.mapal.com





SETTING MEASURING DISPENSING

High-precision setting fixtures and intelligent dispensing systems that we are proud to have developed ourselves.





SETTING | MEASURING | DISPENSING

Setting fixtures

UNISET-V standard 538

UNISET-V vision 538

Dispensing systems

Product overview 540

UNIBASE-M 542

UNIBASE-V 544

UNIBASE-C 546

RELIABLE AND EASY-TO-USE MAPAL SETTING FIXTURES

MAPAL provides the right setting fixture for every tool and setting requirement. The broad portfolio offers setting fixtures from the entry-level segment as well as universal, automated devices with a CNC controller.

For automated devices, you can choose between optical and tactile measuring methods that are μm exact. Particularly when it comes to tools for complete machining, this flexibility yields real productivity advantages. For electronic devices, the company's own adaptable UNISET software supports the measuring and setting processes.



UNISET-V standard

- CNC controller
- Optical or tactile measurement
- Graphical user interface
- Incident light for inspection of cutting edge
- Tool management
- Tool chip for individually reading and recording measured values



UNISET-V vision

- Universal, automated setting
- CNC controller
- Optical or tactile measurement
- Graphical user interface
- Incident light for inspection of cutting edge
- Tool management
- Heel
- Tool chip for individually reading and recording measured values



NETWORKED AND SUSTAINABLE SMART DISPENSING SYSTEMS

The UNIBASE tool dispensing system stands for the optimum storage and management of tools, components and accessories. The diverse portfolio, which enables expansion at a later date, offers the right UNIBASE cabinet for every requirement. Both the individual dispensing systems and the drawer systems – even those for vertical storage of completely assembled tools – offer permanent automatic stock monitoring.

The new software with an open web interface allows the system to be accessed and controlled from any device.

UNIBASE software

- Web interface for external access via an app
- Optional connection to the cloud-based open platform c-Com
- Comprehensive assessment possibilities
- Dispenses items in a few clicks
- Permanent, automatic stock monitoring
- Connection to existing ERP systems possible



UNIBASE-M

- Ideal storage system for tools, parts and accessories
- Limited dispensing for the targeted withdrawal of individual parts
- Variable drawer arrangement



UNIBASE-V

- Safe storage of completely assembled tools
- Storing long tools vertically
- No risk for the cutting edges
- Upright cabinets with roller-guided drawers
- Can be integrated into existing systems
- Proven in use for tool management projects



UNIBASE-C

- Single dispensing system
- Storage of small and individual parts
- Single dispensing solution increases theft protection
- Ready for use as a single solution as well as in existing systems

Technical features UNIBASE-M



1 Monitor

With the 22" touch screen monitor and the tool software, items can be managed clearly and directly.

2 Master cabinet

The master cabinet is the basic module of the UNIBASE-M and contains the monitor and the computer unit for automatic tool dispensing.

3 Barcode scanner

For quick, straightforward searching or stocking, the tools can be read conveniently using a barcode scanner. Alternatively, system logon by barcode is also possible.



4 Additional cabinet (slave unit)

The additional cabinet is part of UNIBASE-M. The drawer division is freely configurable in order to accommodate different items. Up to 30 additional cabinets can be added.

Additional cabinets

MAPAL not only offers a standard range of additional cabinets, but also provides the option of configuring the cabinets as required. The number and height of drawers can be custom arranged according to individual requirements. Subsequent expansion can also be easily implemented by the customer.

Standard designs:

Cabinet features	Additional cabinet with 13 drawers	Additional cabinet with 54 drawers	Additional cabinet with 90 drawers
			
Number of drawers x drawer height	12 x 75 mm	48 x 50 mm	80 x 50 mm
	1 x 150 mm	6 x 100 mm	10 x 100 mm
Housing dimensions (WxDxH)	717 x 750 x 1,390 mm	717 x 750 x 1,390 mm	1,159 x 750 x 1,390 mm
Load capacity per drawer	75 kg	25 kg	25 kg
Useable height	1,050 mm	1,000 mm	1,000 mm
Storage area	4.68 m ²	4.63 m ²	7.72 m ²
Dispensing limit	-	✓	✓

Individual drawers for master cabinet and additional cabinet

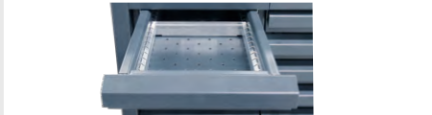
	Drawer width	Drawer height	Drawer raster	Useable height
	612 mm (wide)	75 - 300 mm (variable)	25 mm	1,050 mm
	153 mm (narrow)	50 - 200 mm (variable)	25 mm	1,000 mm

Technical features

UNIBASE-V additional cabinet



1 Master cabinet

The master cabinet is the basic module of the UNIBASE-M and contains the monitor and the computer unit for automatic tool dispensing.

2 UNIBASE-V additional cabinet

The vertical cabinet is controlled via the master unit and has a maximum of four electronically lockable vertical drawers.

3 Vertical drawer

The vertical drawers that open automatically can be individually equipped with tool holders. Up to 600 kg can be stored in each roller-guided drawer.

4 Tool holder

The tool holders are configurable and can be loaded with large, fully assembled and pre-set upright tools.

5 Cabinet lock



The cabinet lock is used to activate and deactivate the emergency unlocking of the vertical drawers.

UNIBASE-V additional cabinets

MAPAL offers the UNIBASE-V additional cabinet in various standard designs which differ in the division of the vertical drawers. For the purpose of meeting individual requirements, the drawer tool holders can be configured as desired. Subsequent expansion can be easily implemented by the customer.

Additional cabinets – vertical cabinet

Standard designs:

Cabinet features	Additional cabinet with 2 vertical drawers	Additional cabinet with 3 vertical drawers	Additional cabinet with 4 vertical drawers
			
Height	2,000 mm	2,000 mm	2,000 mm
Width	717 mm	717 mm	717 mm
Depth	725 mm	725 mm	725 mm
Storage area	1,085 m ²	1,085 m ²	1,085 m ²

Individual vertical drawers for vertical cabinet

Vertical drawer	Width	Raster	Height	Useable height	Usable depth
	155 mm	40 mm	1,960 mm	1,750 mm	628 mm
	315 mm	40 mm	1,960 mm	1,750 mm	628 mm

Technical features

UNIBASE-C



1 UNIBASE-C master system

The UNIBASE-C can be used as an independent system with a computer unit and touch monitor. Further slave systems can also be subsequently integrated into existing systems.

2 Dispensing compartment

The dispensing compartments open automatically after item dispensing. The single dispensing solution allows only one compartment to be opened at a time, therefore supporting a safe and controlled removal procedure for individual items.

3 Software UNIBASE

The revised and user-friendly UNIBASE software can be conveniently operated via touch monitor.



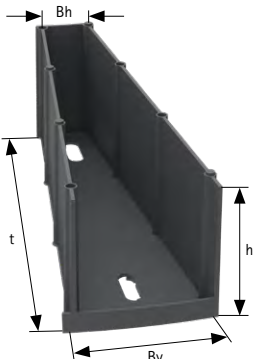

UNIBASE-C single dispensing system

MAPAL offers the UNIBASE-S single dispensing system in various designs. For the purpose of meeting individual requirements, the number and arrangement of the dispensing compartments can be configured. Different drum designs are available for this purpose. The UNIBASE-C is available as a master and slave system.

UNIBASE-C compartment designs

	UNIBASE-C compartment designs				
	Compartment features	Compartment A	Compartment B	Compartment C	Compartment D
	Height (h)	68 mm	68 mm	136 mm	136 mm
	Front width (Bv)	68 mm	140 mm	68 mm	140 mm
	Rear width (Bh)	23 mm	60 mm	23 mm	60 mm
	Depth (t)	237 mm	237 mm	237 mm	237 mm

UNIBASE-C drum designs

Total number of compartments	640 compartments	448 compartments	320 compartments	160 compartments
				
Quantity, compartment A	640	320		
Quantity, compartment B		32	160	
Quantity, compartment C		64	160	
Quantity, compartment D		32		160

Cabinet features

Cabinet feature	Size information
Height	2,000 mm
Width	1,080 mm
Depth	875 mm
Weight	275 kg

Determining a cutting data

Explanation of terms

Cutting depth	$a_p = [\text{mm}]$	Feed per tooth	$f_z = \left[\frac{\text{mm}}{\text{tooth}}\right]$
Cutting width	$a_e = [\text{mm}]$	Cutting speed	$v_c = \left[\frac{\text{m}}{\text{min}}\right]$
Working depth correction factor	k_{AT}	Cone angle correction factor	k_{KW}

Calculation formula

Spindle speed	$n = [\text{min}^{-1}]$	$n = \frac{v_c \cdot 1000}{\pi \cdot d_1}$
Feed rate	$v_f = \left[\frac{\text{mm}}{\text{min}}\right]$	$v_f = f_z \cdot z \cdot n$
Cutting depth correction factor	$a_p \text{ korr.} = [\text{mm}]$	$a_p \text{ korr.} = a_p \cdot k_{AT}$
Spindle speed correction factor	$n \text{ korr.} = [\text{min}^{-1}]$	$n \text{ korr.} = n \cdot k_{AT} \cdot k_{KW}$
Feed rate correction factor	$v_f \text{ korr.} = \left[\frac{\text{mm}}{\text{min}}\right]$	$v_f \text{ korr.} = v_f \cdot k_{AT} \cdot k_{KW}$
Theoretical roughness depth	$R_{th} = [\mu\text{m}]$	$R_{th} = R - \sqrt{R^2 - a_e^2/4}$
Cutting width	$a_e = [\text{mm}]$	$a_e = 2 \cdot \sqrt{R_{th} \cdot ((R \cdot 2) - R_{th})}$

Determining the cutting data

1. Select your workpiece material according to the MMG (MAPAL machining groups, see fold-out page on inside cover)
2. Depending on the tool diameter, you can take the recommendation for a_p , a_e , v_c and f_z from the table of cutting values. These values are valid for tools with a working depth of $\leq 3xD$ and a cone angle of 0° .
3. Depending on the working depth and cone angle, the correction factors for working depth k_{AT} and cone angle k_{KW} below the table of cutting values must be taken into account. Please take note of the calculation formulas.

Theoretical roughness depth R_{th}

		a_e [mm]														
		0,01	0,02	0,03	0,04	0,05	0,06	0,075	0,08	0,1	0,15	0,2	0,25	0,3	0,4	0,5
R [mm]	0,02	0,64	2,68	6,77												
	0,05	0,25	1,01	2,30	4,17	6,70	10,00	16,93								
	0,10	0,13	0,50	1,13	2,02	3,18	4,61	7,30	8,35	13,40						
	0,15	0,08	0,33	0,75	1,34	2,10	3,03	4,76	5,43	8,58						
	0,20	0,06	0,25	0,56	1,00	1,57	2,26	3,55	4,04	6,35	14,60					
	0,25	0,05	0,20	0,45	0,80	1,25	1,81	2,83	3,22	5,05	11,52					
	0,30	0,04	0,17	0,38	0,67	1,04	1,50	2,35	2,68	4,20	9,53	17,16				
	0,40	0,03	0,13	0,28	0,50	0,78	1,13	1,76	2,01	3,14	7,09	12,70				
	0,50	0,03	0,10	0,23	0,40	0,63	0,90	1,41	1,60	2,51	5,66	10,10	15,88			
	0,75	0,02	0,07	0,15	0,27	0,42	0,60	0,94	1,07	1,67	3,76	6,70	10,49	15,15		
	0,90	0,01	0,06	0,13	0,22	0,35	0,50	0,78	0,89	1,39	3,13	5,57	8,72	12,59		
	1,00	0,01	0,05	0,11	0,20	0,31	0,45	0,70	0,80	1,25	2,82	5,01	7,84	11,31		
	1,25	0,01	0,04	0,09	0,16	0,25	0,36	0,56	0,64	1,00	2,25	4,01	6,27	9,03	16,10	
	1,50	0,01	0,03	0,08	0,13	0,21	0,30	0,47	0,53	0,83	1,88	3,34	5,22	7,52	13,39	
	2,00	0,01	0,03	0,06	0,10	0,16	0,23	0,35	0,40	0,63	1,41	2,50	3,91	5,63	10,03	15,69
	2,50	0,01	0,02	0,05	0,08	0,13	0,18	0,28	0,32	0,50	1,13	2,00	3,13	4,50	8,01	12,53
	3,00	0,00	0,02	0,04	0,07	0,10	0,15	0,23	0,27	0,42	0,94	1,67	2,61	3,75	6,67	10,43
4,00	0,00	0,01	0,03	0,05	0,08	0,11	0,18	0,20	0,31	0,70	1,25	1,95	2,81	5,00	7,82	
5,00	0,00	0,01	0,02	0,04	0,06	0,09	0,14	0,16	0,25	0,56	1,00	1,56	2,25	4,00	6,25	
6,00	0,00	0,01	0,02	0,03	0,05	0,08	0,12	0,13	0,21	0,47	0,83	1,30	1,88	3,33	5,21	
8,00	0,00	0,01	0,01	0,03	0,04	0,06	0,09	0,10	0,16	0,35	0,63	0,98	1,41	2,50	3,91	
10,00	0,00	0,01	0,01	0,02	0,03	0,05	0,07	0,08	0,13	0,28	0,50	0,78	1,13	2,00	3,13	

Theoretical roughness depth R_{th} [μm]

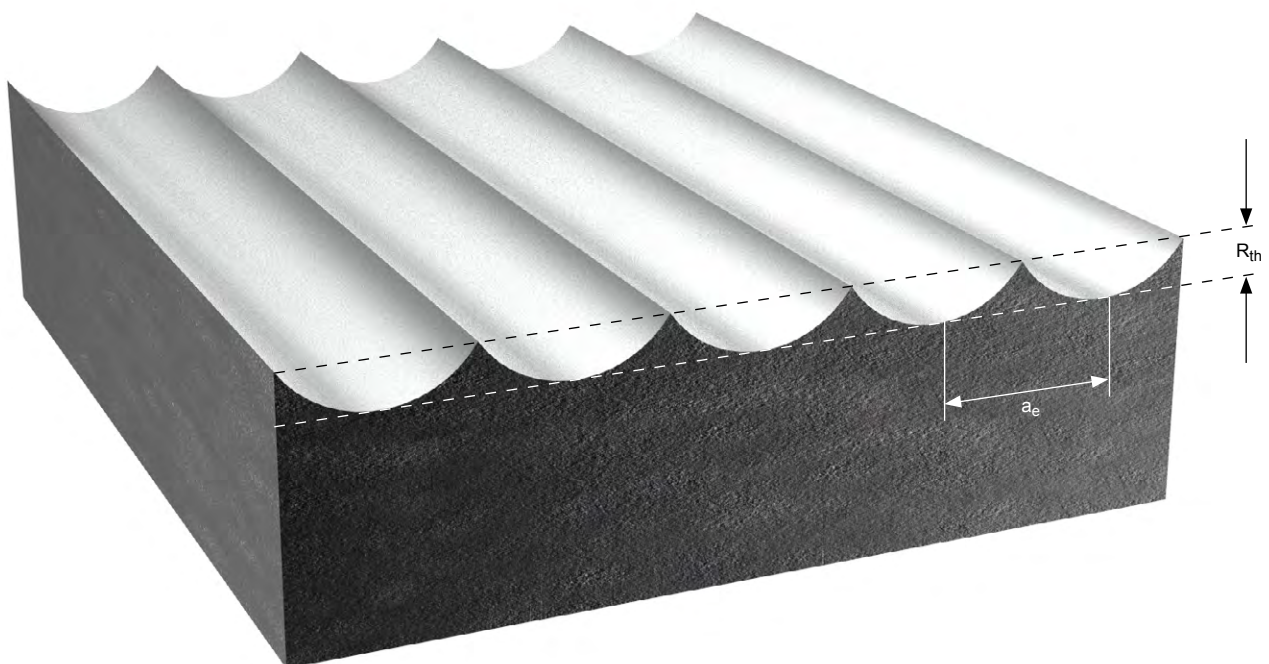

Calculation examples for cutting data recommendations

Cutting data taking into account the correction factors

OptiMill-MBN/-MCR:

Tool: MBN105-120-0500-5000B100-HP801
 Application: Roughing
 Tool diameter: 10 mm
 Working depth AT: ≤ 10xD
 Taper angle φ: 1°
 Incline: 1°
 Workpiece material: S235JRC



		a_p [mm]	a_e [mm]	v_c [m/min]	f_z [mm]
P1.1	Structural, machining, case hardened and tempering steels, unalloyed	1 0,05xD	< 0,25xD	300	0,200

2 Working depth correction factor - k_{AT}

AT	k_{AT}		
	a_p	n	v_f
≤ 10xD	0,50	0,70	0,70

3 Cone angle correction factor - k_{KW}

φ [°]	k_{KW}		
	a_p	n	v_f
1	1,02	1,02	1,02

Calculation	Calculation formula	Example of calculation
Cutting depth correction factor	$a_p \text{ korr.} = a_p \cdot k_{AT} = [0,05 \times d_1] \cdot k_{AT}$	1 2 $0,05 \cdot 10 \cdot 0,50 = 0,25 \text{ mm}$
Spindle speed correction factor	$n \text{ korr.} = n \cdot k_{AT} \cdot k_{KW} = \left[\frac{300 \cdot 1000}{\pi \cdot 10} \right] \cdot k_{AT} \cdot k_{KW}$	2 3 $9554 \text{ min}^{-1} \cdot 0,70 \cdot 1,02 = 6821 \text{ min}^{-1}$
Feed rate correction factor	$v_f \text{ korr.} = v_f \cdot k_{AT} \cdot k_{KW} = [0,2 \cdot 4 \cdot 9554] \cdot k_{AT} \cdot k_{KW}$	2 3 $7643 \frac{\text{mm}}{\text{min}} \cdot 0,70 \cdot 1,02 = 5457 \frac{\text{mm}}{\text{min}}$

OptiMill-SCM:

Tool: SCM740-1000Z04R-F0020HB-HP920
 Application: Roughing
 Tool diameter: 10 mm
 Design: Extra long
 Workpiece material: S235JRC



	v_c [m/min]	f_z [mm]
P1.1 Structural, machining, case hardened and tempering steels, unalloyed	① 355	② 0,090

③ Tool length correction factor - k_{WL}

Length	Correction factors	
	f_z	v_c
Extra long	0.6	0.7

Calculation**Calculation formula****Example of calculation**

Cutting speed correction factor	$v_c \text{ korr.} = v_c \cdot k_{WL}$	① ③ $355 \frac{\text{m}}{\text{min}} \cdot 0,60 = 213 \frac{\text{m}}{\text{min}}$
Feed per tooth correction	$f_z \text{ korr.} = f_z \cdot k_{WL}$	② ③ $0,090 \cdot 0,60 = 0,054 f_z$

Pictograms

Milling



	Face milling		Shoulder milling		Groove milling		Deep groove milling
	Trimming		Chamfer milling		Profile milling		Plunge milling
	Ramps		Helix milling		Trochoidal milling		High-feed milling
	Pocket milling		With designated working depth, cylindrical		With designated working depth, conical		Corner radius
	45° chamfer		Sharp-edged		Internal cooling		For lateral material removal rate
	For lateral material removal rate and angled entry		For lateral material removal rate, angled entry and recess		Cylindrical shank compatible with HA according to DIN 6535		Cylindrical shank compatible with HB according to DIN 6535
	Connection CFS/MFS		Short		Long		Overlong
	Extra long		Maximum machining depth		According to factory standard		Design DIN 6527

Drilling from solid | Countersinking



	Drilling from solid		Stepped drilling		Deep drilling		Tapping
	Countersinking		Cross bore		Inclined bore entrance		Inclined bore outlet
	Flat bottom of the bore		Drilling reaming		High-feed machining		Drilling in packages
	180°		H7		H7		Tool grinding diameter tolerance
	Pilot bore		Maximum achievable bore tolerance of ≥IT		Preferred series in H7		Shank form HA according to DIN
	Maximum machining depth		Internal cooling		QTS connection		DIN 6535
	Shank form HB according to DIN		Shank form HE according to DIN		Design according to DIN 335 C		Lowering angle

Reaming



	Through hole		Blind bore		Preferred series in H7		Maximum achievable bore tolerance of ≥IT
	Tool grinding diameter tolerance		Internal cooling		Shank form HA according to DIN		

Configuration  Product with configurable features

Product category





Basic Line:
Universal tools, broad field of application, low procurement costs



Performance Line:
High-performance tools, broad field of application, high productivity in series production



Expert Line:
Specialist tools for selected applications, maximum precision and productivity

Material suitability  Highly suitable  Suitable in some situations

E.g. Standard material suitability table

P	1	2	3	4	5	6	M	1	2	3	K	1	2	3	N	1	2	3	4	S	1	2	3	4	5	H	1	2	3
	■	■	■	■							■	■																	

E.g. Material suitability table for non-ferrous metal and lightweight materials

N	1.1	1.2	1.3	1.4	2.1	2.2	2.3	3.1	4.1	4.2	4.3	C	1.1	1.2	1.3	2.1	3.1	4.1	4.2	5.1	5.2	5.3
										■			■		■			■	■			

OptiMill®-3D: Tolerances

Tool type	Description	Nominal diameter d ₁	Shank diameter d ₂	Radial contour
MBN	OptiMill-3D-BN OptiMill-3D-BN-Hardened	f7	h5	±0.005 if d ₁ ≤ 6 mm ±0.01 if d ₁ > 6 mm
	OptiMill-3D-BN-Copper	f7	h5	±0,01
	OptiMill-3D-BN-Alu	f7	h5	±0,01
	OptiMill-3D-BN-Graphite z2	0 / -0.015 if d ₁ ≤ 0.3 mm -0.002 / -0.015 if d ₁ ≤ 3 mm -0.02 if d ₁ > 3 mm f7 if d ₁ = d ₂	h5	±0.005 if d ₁ ≤ 2 mm +0.01 / -0.015 if d ₁ > 2 mm
	OptiMill-3D-BN-Graphite z3	-0,02	h5	±0,01
	OptiMill-3D-BN-Graphite-MT	-0,1	h5	
MCR	OptiMill-3D-CR OptiMill-3D-CR-Hardened	f7	h5	±0.005 if d ₁ ≤ 6 mm ±0.01 if d ₁ > 6 mm
	OptiMill-3D-CR-Copper	f7	h5	±0,01
	OptiMill-3D-CR-Alu	f7	h5	±0,01
	OptiMill-3D-CR-Graphite z2, z4	-0.002 / -0.015 if d ₁ ≤ 3 mm -0.02 if d ₁ > 3 mm f7 if d ₁ = d ₂	h5	±0.005 if d ₁ ≤ 6 mm ±0.01 if d ₁ > 6 mm
	OptiMill-3D-CR-Graphite z3	-0.005 / -0.02 if d ₁ ≤ 3 mm -0.005 / -0.03 if d ₁ ≤ 6 mm f7 if d ₁ = d ₂	h5	±0.005 if d ₁ ≤ 6 mm ±0.01 if d ₁ > 6 mm
MCS	OptiMill-3D-CS	f8	h6	
MHF	OptiMill-3D-HF OptiMill-3D-HF-Hardened	f8	h6	

MAPAL machining groups

Machining group		Workpiece material	Strength/hardness [N/mm ²] [HRC]	Frequently machined workpiece materials
P	P1	P1.1 Construction steels, machining steels, case-hardening and tempering steels, unalloyed	< 700 N/mm ²	1.0122 (S235/St 37), 1.0401 (C15), 1.0503 (C45), 1.0570 (S355/St 52), 1.1213 (CF53)
		P1.2 Structural, machining, case hardened and tempering steels, unalloyed	< 1,200 N/mm ²	1.1249 (CF70)
	P2	P2.1 Nitriding, case-hardening and tempering steels, alloyed	< 900 N/mm ²	1.7131 (16MnCr5)
		P2.2 Nitriding, case-hardening and tempering steels, alloyed	< 1,400 N/mm ²	1.7227 (42CrMoS4)
	P3	P3.1 Tool steels, roller bearing steels, spring steels and high-speed steels*	< 800 N/mm ²	1.2343 (X37CrMoV5-1), 1.2762 (75CrMoNiW6-7)
		P3.2 Tool steels, roller bearing steels, spring steels and high-speed steels*	< 1,000 N/mm ²	1.2367 (X38CrMoV5-3), 1.2713 (55NiCrMoV6)
		P3.3 Tool steels, roller bearing steels, spring steels and high-speed steels*	< 1,500 N/mm ²	1.2379 (X153CrMoV12) 1.2738 (40CrMnNiMo8-6-4)
	P4	P4.1 Stainless steels, ferritic and martensitic		1.4510 (X3CrTi17), 1.4589 (X5CrNiMoTi15-2)
	P5	P5.1 Cast steel		1.7231 (G42CrMo4)
	P6	P6.1 Stainless cast steels, ferritic and martensitic		
M	M1	M1.1 Stainless steels, austenitic	< 700 N/mm ²	1.4301 (V2A), 1.4571 (V4A)
		M1.2 Stainless steels, ferritic/austenitic (duplex)	< 1,000 N/mm ²	1.4362 (Alloy 2304), 1.4501, 1.4662 (LDX 2404)
	M2	M2.1 Stainless cast steel, austenitic	< 700 N/mm ²	
M3	M3.1 Stainless cast steel, ferritic/austenitic (duplex)	< 1,000 N/mm ²		
K	K1	K1.1 Cast iron with lamellar graphite (grey cast iron), GJL	< 300 N/mm ²	GJL-250 (GG-25), GJL-260 (GG-26 Cr)
		K2.1 Cast iron with spheroidal graphite, GJS	< 500 N/mm ²	GJS-400 (GGG-40), GJS-450 (GGG-45)
	K2	K2.2 Cast iron with spheroidal graphite, GJS	≤ 800 N/mm ²	GJS-600 (GGG-60), GJS-800-2 (GGG-80), GJS-800-8 (ADI 800)
		K2.3 Cast iron with spheroidal graphite, GJS	> 800 N/mm ²	GJS-900-2 (GGG-90), GJS-1000-5 (ADI 1000), GJS-1200-2 (ADI 1200), GJS-1400-1 (ADI 1400)
	K3	K3.1 Cast iron with vermicular graphite, GJV; malleable cast iron, GJM	< 500 N/mm ²	GJV-300, GJV-400, GJMW-400-5 (GTW-40)
K3.2 Cast iron with vermicular graphite, GJV; malleable cast iron, GJM		> 500 N/mm ²	GJV-500, GJV-700	
N	N1	N1.1 Aluminium, unalloyed and alloyed < 3 % Si		Alloy 2024, Alloy 7075, Al99
		N1.2 Aluminium, alloyed ≤ 7 % Si		AlSi7
		N1.3 Aluminium, alloyed > 7 - 12% Si		AlSi9, AlSi9Cu
		N1.4 Aluminium, alloyed > 12% Si		AlSi12, AlSi17
	N2	N2.1 Copper, unalloyed and low-alloyed	< 300 N/mm ²	SE-Cu
		N2.2 Copper, alloyed	> 300 N/mm ²	CuSn6
		N2.3 Brass, bronze, gunmetal	< 1,200 N/mm ²	CuZn33, CuAl9Mn3
	N3	N3.1 Graphite, > 8 µm		
		N3.2 Graphite, ≤ 8 µm		
	N4	N4.1 Plastic, thermoplastics		PA, PE, PC, PS, PVC, PP, PTFE, POM, PMMA
N4.2 Plastic, duroplastics			PU, PF, EP, UP, VE, CR	
N4.3 Plastic, foam materials			EPS, PUR, PVC-E, PS-E, PP-E	
C	C1	C1.1 Plastic range, reinforced with aramid fibre (AFK)		Nomex, Kevlar, Twaron, KOREX
		C1.2 Plastic range (duroplastic), CFK/GFK		IMS, HTA
		C1.3 Plastic range (thermoplastic), CFK/GFK		GMT-PP, PEEK
	C2	C2.1 Carbon range, reinforced with carbon fibre (CFC)		CF222, CF225, CF226, CF227, CF260
		C3.1 Metal matrix (MMC)		CeramTec AO-403 (AlSi9MgMn-Al2O3), Al/Cu/Mg-SiO2/Al2O3/AlN/TiC/SiC/BN/TiB2
	C4	C4.1 Sandwich construction, honeycomb core (Honeycomb)		
		C4.2 Sandwich construction, foam core		PLASCORE PAMG-XR1 5052, PCGA-XR1 3003, PAMG-XR1 5056, Micro-Cell (core made of alloy 5052/5056)
	C5	C5.1 Multilayer composite (stack), non-metallic non-ferrous metal composite		CFK-aluminium, IMS/HTA + Alloy 2024/6061/7075
		C5.2 Multilayer composite (stack), non-metallic metal composite		CFK-titanium, IMS/HTA + TiAl6V4/AMS4905
		C5.3 Multilayer composite (stack), non-metallic non-metal composite		CFK-CFK
		C5.4 Multilayer composite (stack), non-ferrous metallic non-ferrous metal composite		Aluminium-aluminium
		C5.5 Multilayer composite (stack), non-ferrous metallic metal composite		Aluminium-titanium
C5.6 Multilayer composite (stack), metallic metal composite			Titanium Inox	
S	S1	S1.1 Titanium, titanium alloys	< 400 N/mm ²	
		S2.1 Titanium, titanium alloys	< 1,200 N/mm ²	TiAl6V4
	S2	S2.2 Titanium, titanium alloys	> 1,200 N/mm ²	
		S3.1 Nickel, unalloyed and alloyed	< 900 N/mm ²	1.3912 (Invar, Ni36)
	S3	S3.2 Nickel, unalloyed and alloyed	> 900 N/mm ²	
S4	S4.1 High-temperature super alloy, Ni-, Co-, and Fe-based		Hardox, Hastelloy, Incoloy, Inconel, NIMONIC, Stellite, Waspaloy	
S5	S5.1 Molybdenum and tungsten alloys			
H	H1	H1.1 Hardened steel / cast steel	< 44 HRC	1.2738 HH, 1.2085, Toolox 33, Toolox 44
		H1.2 Hardened steel / cast steel	< 55 HRC	1.2343, 1.2311, 1.2312, 1.2714, 1.2083, 1.2738
	H2	H2.1 Hardened steel / cast steel	< 60 HRC	1.1730, 1.2379, 1.2358, 1.2767, 1.4112, ASP 2012
		H2.2 Hardened steel / cast steel	< 65 HRC	1.2379, 1.2363, 1.2436, 1.2842, ASP 2005, Vanadis 23
	H3	H3.1 Wear-resistant cast/chill casting, GJN	< 68 HRC	ASP 2017, ASP 2023, Vanadis 30, Vanadis 60

* If the alloy parts Cr, Mo, Ni, V, W is > 8% in total, then select the next highest MAPAL machining group.

OptiMill®-3D: Determining the working depth

1. Depending on the different inclines on the part, the neck length specified with l_3 can be used to the maximum for the respective tool (see Figure 1).
2. The maximum working depth at x° incline can be taken from the respective product page. The working depth represents the machining depth at which the contour of the tool collides with the part. If no value is specified, the maximum possible working depth depends on the chuck used (see example on the right).
3. For greater stability in deeper machining and 5-axis applications, tools with different taper angles (0.5°, 1°, 1.5° and 3°) are available. The taper angle should be selected according to the incline on the part. The cylindrical part with neck withdrawal ensures a sufficient distance between the tool and part (see Figure 2).
4. For maximum stability, the largest possible taper angle can be selected depending on the required working depth – even if it exceeds the angle of the incline.

Example:

An OptiMill-3D-BN (MBN101) with a diameter of 5 mm and a l_3 dimension of 20 mm can achieve a maximum working depth of 21 mm with an incline of 0.5°. With an incline of 3°, the working depth is not limited by the tool contour in this way. The maximum working depth then depends on the chuck used.

Working depth at x° incline			
0.5°	1°	1.5°	3°
21.00	21.82	22.59	-

Figure 1: Working depth depending on incline

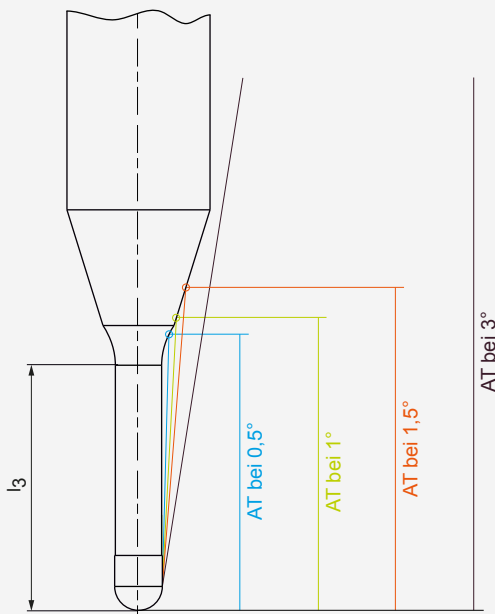

AT = Working depth

Figure 2: Taper angle and neck withdrawal

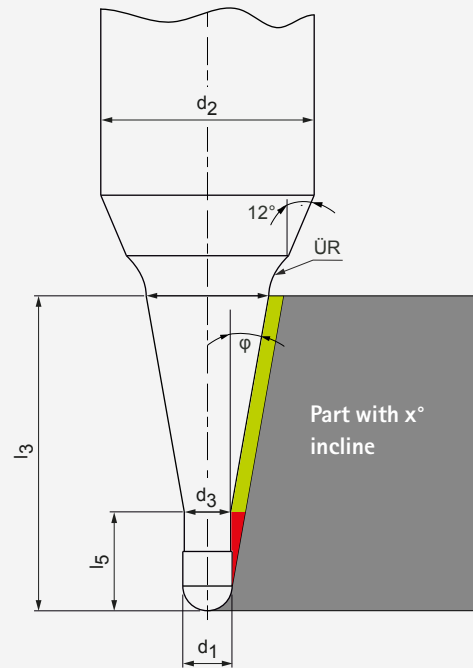

Taper angle free space

Cylindrical part free space

Explanation of terms

Taper angle	$\varphi = [^\circ]$	Working depth	AT = [mm]
Neck length	$l_3 = [\text{mm}]$	Transition radius	$\ddot{U}R = [\text{mm}]$
Cylindrical length	$l_5 = [\text{mm}]$	Neck diameter	$d_3 = [\text{mm}]$
Blade diameter	$d_1 = [\text{mm}]$	Shank diameter	$d_2 = [\text{mm}]$



Discover tool and service solutions now that give you a lead:

BORE MACHINING

REAMING | FINE BORING

DRILLING FROM SOLID | BORING | COUNTERSINKING

MILLING

CLAMPING

TURNING

ACTUATING

SETTING | MEASURING | DISPENSING

SERVICES

FOLLOW US

